

# Owner's Manual & Assembly Instructions

01

Model No. **EH65-A**

**VL6562-A**

**EH65S**

**WL65-A**

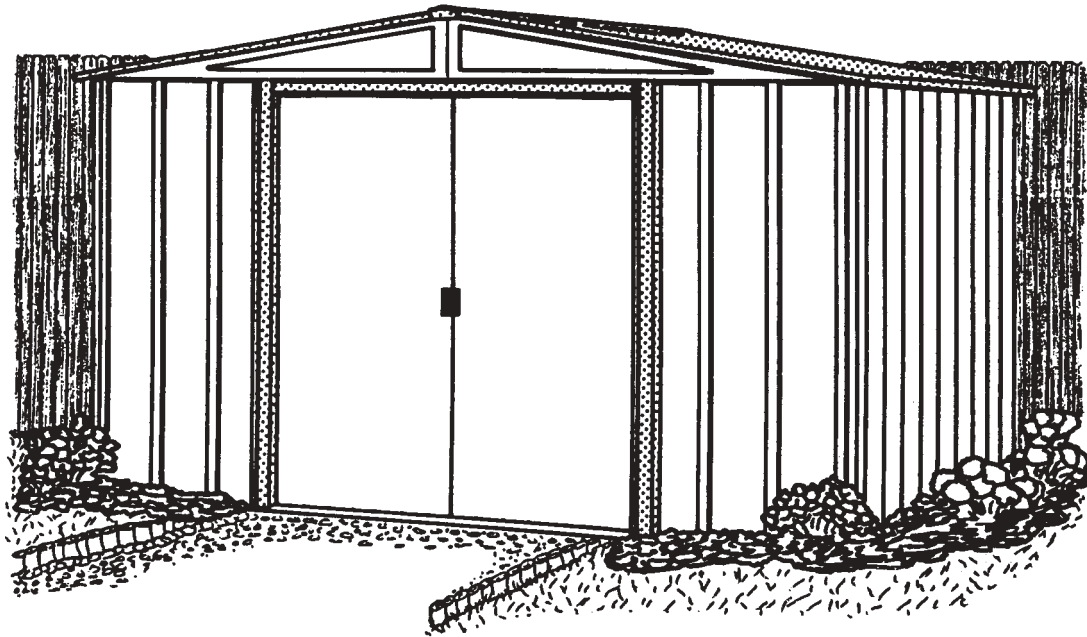

709120306

**BUILDING DIMENSIONS** \* Size rounded off to the nearest foot



**CAUTION: SOME PARTS HAVE SHARP EDGES. CARE MUST BE TAKEN WHEN HANDLING THE VARIOUS PIECES TO AVOID A MISHAP. FOR SAFETY SAKE, PLEASE READ SAFETY INFORMATION PROVIDED IN THIS MANUAL BEFORE BEGINNING CONSTRUCTION. WEAR GLOVES WHEN HANDLING METAL PARTS.**

*Approx. Size	Foundation Size	Storage Area Sq. Ft. Cu. Ft.		Exterior Dimensions (Roof Edge to Roof Edge)			Interior Dimensions (Wall to Wall)			Door Opening	
				Width	Depth	Height	Width	Depth	Height	Width	Height
6' x 5'	74" x 57"	27	147	76 1/4"	59 1/2"	69 7/8"	71 1/4"	54 1/4"	68 5/8"	32"	60"
1,8m x 1,4m	188cm x 145cm	2,5m <sup>2</sup>	4,2m <sup>3</sup>	194cm	151cm	177cm	181cm	138cm	174cm	81cm	152cm

# BEFORE YOU BEGIN....

A2

## Owner's Manual

Before beginning construction, check local building codes regarding footings, location and other requirements. Study and understand this owner's manual.

Important information and helpful tips will make your construction easier and more enjoyable.

**Assembly Instructions:** Instructions are supplied in this manual and contain all appropriate information for your building model. Review all instructions before you begin, and during assembly, follow the step sequence carefully for correct results.

**Foundation and Anchoring:** Your storage building must be anchored to prevent wind damage. A foundation is also necessary as a base in order to construct a square and level building. Anchoring and foundation materials are not included with your building. We recommend the combined use of an **Arrow Floor Frame Kit** and an **Arrow Anchoring Kit** as an effective method of securing your building to the ground (Available by mail order or at your local dealer) or you may construct a foundation and anchoring system of your choice. Your assembly instructions provide information on a few methods commonly used to secure and level a storage building.

**Parts and Parts List:** Check to be sure that you have all the necessary parts for your building.

- All part numbers can be found on the parts. All of these numbers (before the -) must agree with the numbers on the parts list. The parts list is located on page 12.

- If you find that a part is missing, include the model number of your building and contact:

**Arrow Group Industries, Inc. Customer Service Department**  
**Route 50 East Breese, Illinois 62230**  
**1-800-851-1085**

- Separate contents of the carton by the part number while reviewing parts list. The first few steps show how to join related parts to make larger sub assemblies which will be used later.

- Familiarize yourself with the hardware and fasteners for easier use during construction. These are packaged within the carton. Note that extra fasteners have been supplied for your convenience.

# PLAN AHEAD....

A3

**Watch the Weather:** Be sure the day you select to install your building is dry and calm. Do not attempt to assemble your building on a windy day. Be careful on wet or muddy ground.

**Teamwork:** Whenever possible, two or more people should work together to assemble your building. One person can position parts or panels while the other is able to handle the fasteners and the tools.

**Tools and Materials:** These are some basic tools and materials you will need for the construction of your building. Decide which method of anchoring and the type of foundation you wish to use in order to form a complete list of the materials you will need.

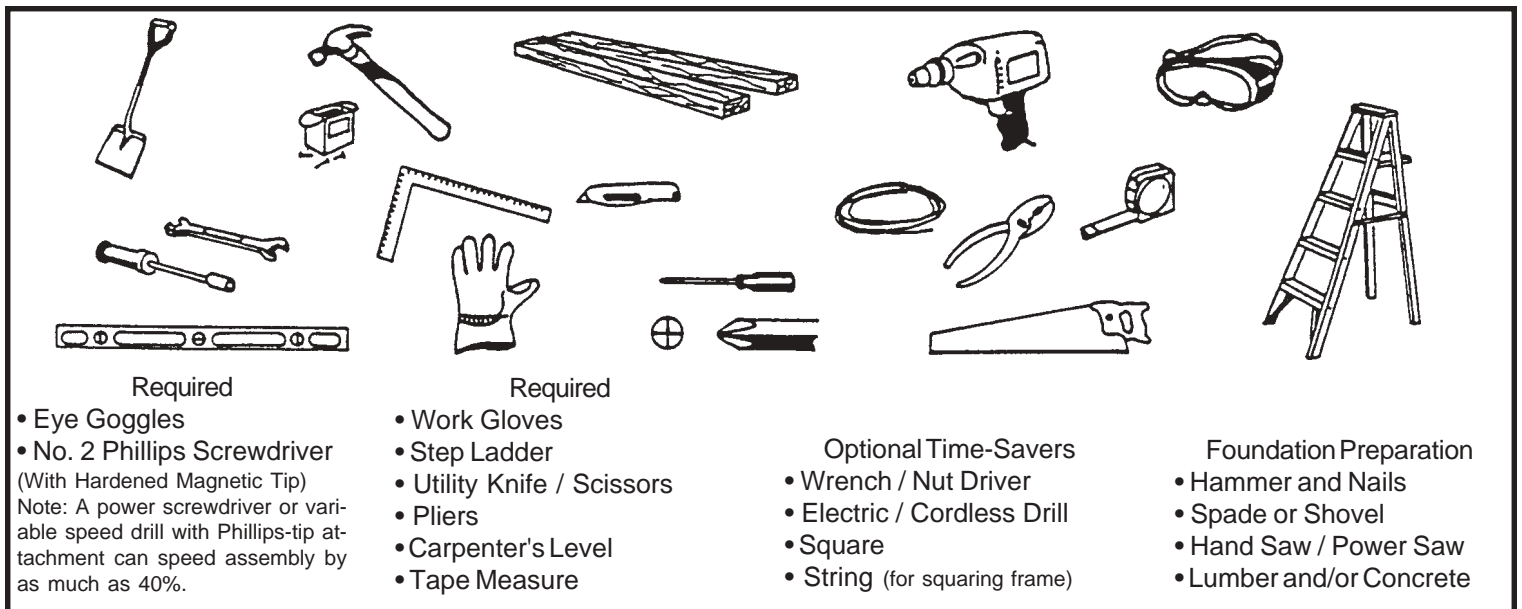

**Selecting and Preparing Your Site:** Before assembly, you will want to decide on a location for your building. The best location is a level area with good drainage.

- Allow enough working space for ease of moving parts into position during assembly. Be sure there will be enough space at entrance for doors to open fully and enough space around the building to be able to fasten the panel screws from the outside.

- Before you begin the first steps in assembling your parts, a foundation should be constructed and an anchoring system should be ready to use.

# SAFETY FIRST...

A4

**Safety precautions are important to follow throughout the construction of your building.**

•Care must be taken when handling various pieces of your building since some contain sharp edges. Please wear work gloves, eye protection and long sleeves when assembling or performing any maintenance on your building.

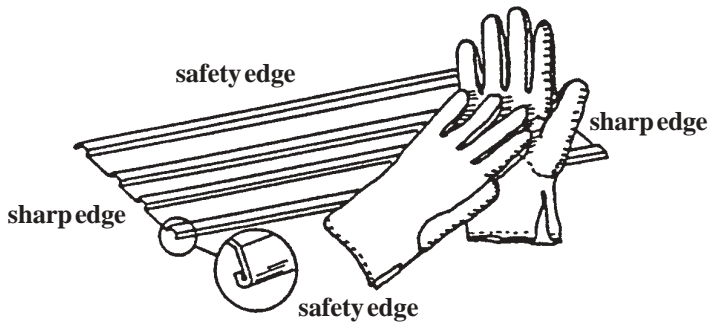

•Keep children and pets away from worksite to avoid distractions and any accidents which may occur.



•Never concentrate your total weight on the roof of the building. When using a step ladder make sure that it is fully open and on even ground before climbing on it.

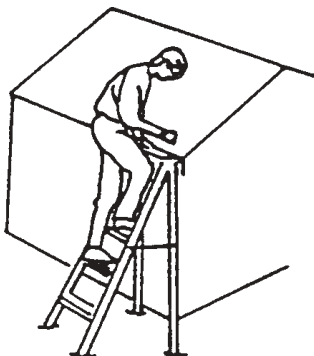

•Practice caution with the tools being used in the assembly of this building. Be familiar with the operation of all power tools.

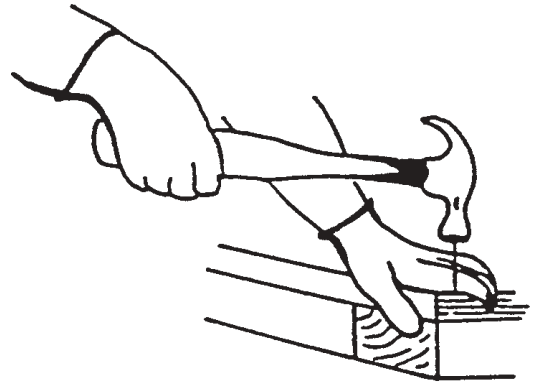

•Do not attempt to assemble the building if parts are missing because any building left partially assembled may be seriously damaged by light winds. Call 1-800-851-1085

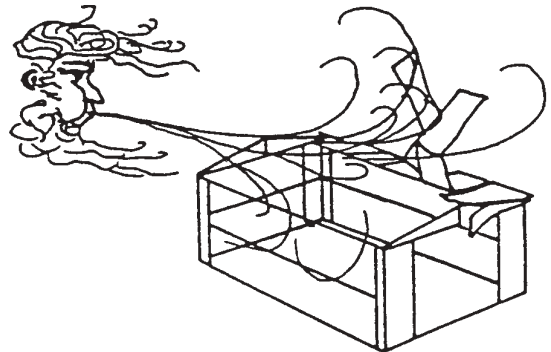

•Do not attempt to assemble the building on a windy day, because the large panels acting as a "sail", can be whipped about by the wind making construction difficult and unsafe.

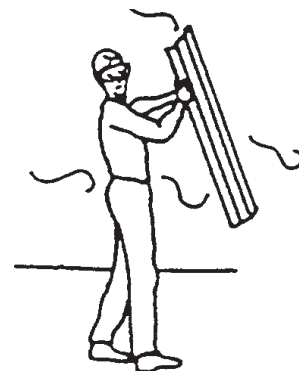

# CARE & MAINTENANCE....

A5 Web

**Finish:** For long lasting finish, periodically clean and wax the exterior surface. Touch-up scratches as soon as you notice them on your unit. Immediately clean the area with a wire brush; wash it and apply touch-up paint per manufacturer's recommendation.

**Roof:** Keep roof clear of leaves and snow with long handled, soft-bristled broom. Heavy amounts of snow on roof can damage building making it unsafe to enter. In snow country, Roof Strengthening Kits are available for most Arrow Buildings for added protection against heavy snow accumulation.

**Doors:** Always keep the door tracks clear of dirt and other debris that prevent them from sliding easily. Lubricate door track annually with furniture polish or silicone spray. Keep doors closed and locked to prevent wind damage.

**Fasteners:** Use all washers supplied to protect against weather infiltration and to protect the metal from being scratched by screws. Regularly check your building for loose screws, bolts, nuts, etc. and retighten them as necessary.

**Moisture:** A plastic sheet (vapor barrier) placed under the entire floor area with good ventilation will reduce condensation.

## Other Tips....

- Wash off inked part numbers on coated panels with soap and water.
- Silicone caulking may be used for watertight seals throughout the building.

**Do not store swimming pool chemicals in your building. Combustibles and corrosives must be stored in air tight approved containers.**

**Keep this Owner's Manual and Assembly Instructions for future reference.**

# ACCESSORIES...

A6 WEB

## ROOF STRENGTHENING (heavy snow load) KITS

Extra roof beams and gable braces designed for added protection against heavy snow accumulation. Increases the strength of your roof by 50%.

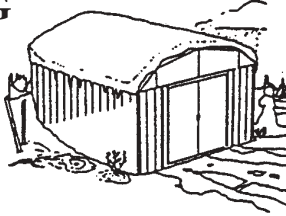

## ANCHOR KITS

### Model No. AK4

Anchor Kit contains heavy-duty steel augers, 60' (18m) of steel cable and 4 cable clamps. No digging or concrete pouring, just insert cable under roof, over roof beams, into augers and twist augers into the ground. For buildings larger than 10'x9', use 2 kits.

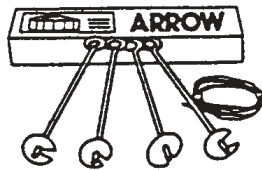

### Model No. AK100

New concrete anchor system permits anchoring any size Arrow building directly to a concrete slab. Each kit contains heavy-duty, hot-dipped galvanized steel corner gussets and perimeter clips which fit over the floor frame and lag bolt into a concrete slab. Full assembly instructions and a 1/4" masonry drill bit are included.

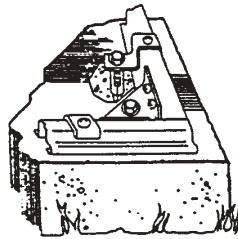

### Model No. AK600

Earth Anchor Kit anchors any size Arrow building to the ground. Each kit contains heavy duty, hot-dipped galvanized steel corner gussets and 4 earth anchors.

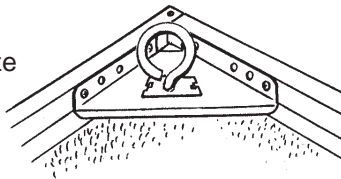

## TOOL HANGING RACK

### Model No. TH100

The perfect tool organizer. Twin 25 1/2" (65cm) steel channels plus five heavy-duty snap-in hangers and a small tool holder for screwdrivers, pliers, etc. Holders slide along channel for fully adjustable spacing. Great for garage, basement, or the back of any door. Fits all Arrow storage buildings.

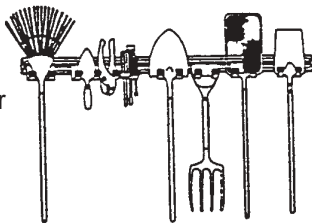

## FLOOR FRAME KITS

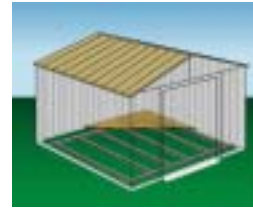

MODELS FB47410, FB5465, FB106-A  
FB109-A and FB1014-A

A simple new floor frame system made of heavy-duty, hot-dipped galvanized steel. Use as foundation for plywood, sand or stone.

## ATTIC KIT / WORKBENCH KIT

Heavy-duty galvanized steel bars that fit all 10' wide Arrow buildings. They install quickly and easily to help organize space and create more useable space as an attic or workbench. Will hold up to 250 lbs. (113kg) evenly distributed.

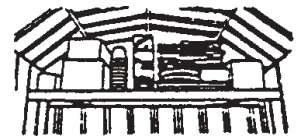

Model No.	Fits	Shipping Weight
AT101	10' Long, 250 lb. (113kg) load+ Fits all Arrow 10' wide buildings.	16 lbs. (7kg)

Must be drilled for use as workbench in Estator.  
+ Even weight distribution.

## SHELF UNITS

Heavy-duty, galvanized steel shelf units help organize storage space. They easily mount on the wall or sit on the floor. Fits all Arrow buildings.\*

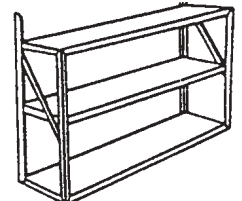
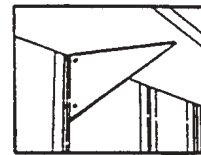
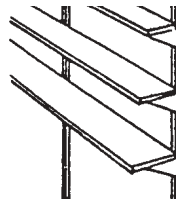

Model No. SS404

- Makes 8" to 12" (20-30cm) wide shelves in any length.
- Brackets, braces, hardware included. Lumber is not included.

Model No. SS900-A

- Grey color
- 3 shelves
- Holds up to 85 lbs. (38kg) (even weight distribution)

\* Some drilling required to fit buildings without mid-wall bracing.

THIS  
PAGE  
WAS  
LEFT  
BLANK  
INTENTIONALLY

THIS  
PAGE  
WAS  
LEFT  
BLANK  
INTENTIONALLY



# Foundation

C09

## The Foundation For Your Building

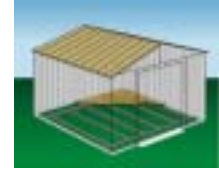

### OPTION 1: ARROW FLOOR FRAME KIT: (Order No. FB5465)

Arrow has the best base for your building in this simple kit. It keeps stored items above the ground. This kit should be used with one of the following:

**A.** To support a plywood deck **B.** To be filled with sand. We recommend the combined use of **1. an ARROW FLOOR FRAME KIT** and **2. an ARROW ANCHORING KIT** as an effective method of securing the building to the ground. **Allow 1 - 2 hours for construction.**

### OPTION 2: Wood Platform

If you decide to build your own foundation, be sure to select the appropriate materials.

These are the recommended materials for your foundation:

- 2 x 4's (5cm x 10cm) Pressure Treated Lumber
- 5/8" (1,5cm) 4 x 8 (122cm x 244cm) Plywood-exterior grade
- 10 & 4 penny Galvanized Nails
- Concrete Blocks (optional)

The platform should be level and flat (free of bumps, ridges etc.) to provide good support for the building. The necessary materials may be obtained from your local lumber yard.

To construct the foundation follow instructions and diagram.

- Construct frame (using 10 penny galvanized nails)
- Measure 16"/24" (40,6cm/61cm) sections to construct inside frame (see diagram)
- Secure plywood to frame (using 4 penny galvanized nails)

Allow 6 - 7 hours for construction.

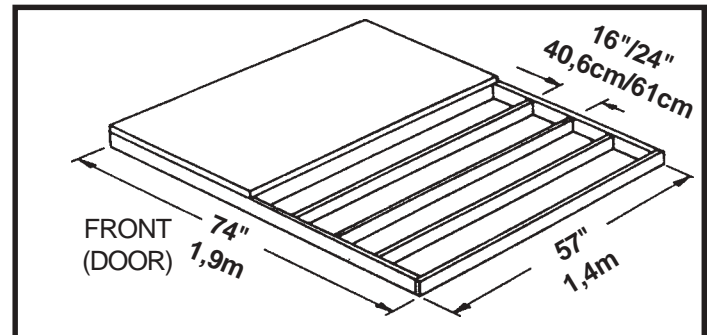

**Note:** Platform/Slab will extend 9/16" (1,4cm) beyond floor frame on all four sides. Seal this 9/16" of wood with a roofing cement (not included), or bevel this 9/16" of concrete when pouring, for good water drainage.

### OPTION 3: Concrete Slab

The slab should be at least 3" to 4" (8-10cm) thick. It must be level and flat to provide good support for the frame.

The following are the recommended materials for your foundation.

- 1 x 4's (2,5cm x 10cm) (will be removed once the concrete cures)
- Concrete
- Sheet of 6 mil plastic
- We recommend for a proper strength concrete to use a mix of:  
1 part cement ● 3 parts pea sized gravel ● 2 1/2 parts clean sand

Prepare the Site/Construct a Foundation

1. Dig a square, 6" (15cm) deep into the ground (remove grass).
2. Fill up to 4" (10cm) in the square with gravel and tamp firm.
3. Cover gravel with a sheet of 6 mil plastic.
4. Construct a wood frame using four planks of 1x4 (2,5cm x 10cm) lumber.
5. Pour in concrete to fill in the hole and the frame giving a total of 4" (8-10cm) thick concrete. Be sure surface is level.

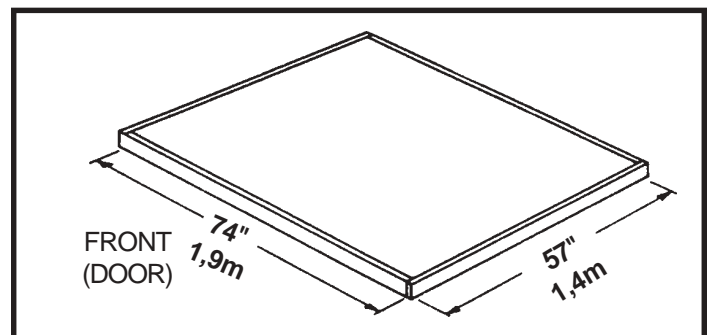

Note: Finished Slab dimensions, with lumber removed.

Allow 3 - 5 hours for construction and a week for concrete curing time.

# Anchoring

A10

## Anchoring Down The Building

**It is important that the entire floor frame be anchored after the building is erected.**

Below are recommended ways of anchoring.

**Arrow Anchoring Kit:** (Model No. AK4 or 60298)

Recommended for use with **any** suggested **base**.

**Contains:** 4 Anchors with Cable, Clamps and installation instruction.

**Anchoring into Wood/Post:**

Use 1/4" Wood Screws. There are 1/4" (0,63cm) dia. holes provided in the frames for proper anchoring.

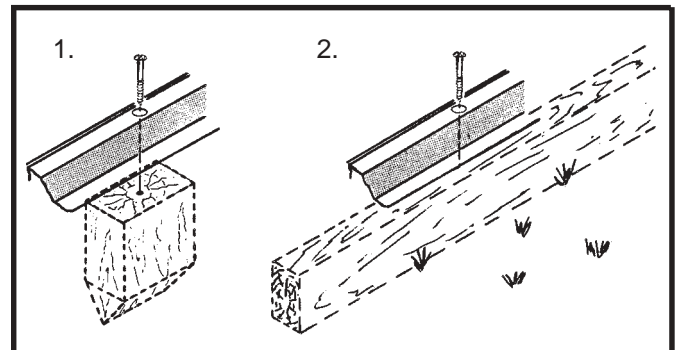
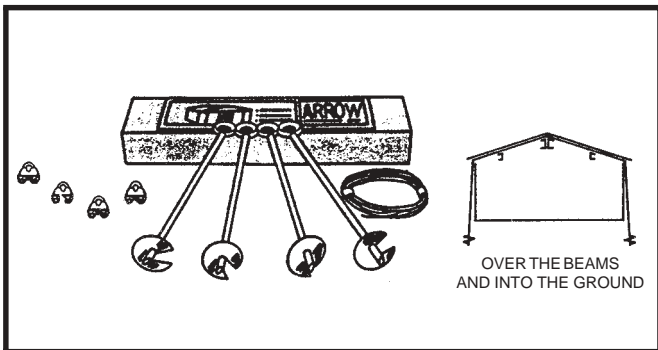

**Arrow Anchoring Kit:** (Model No. AK100 or 68383)

Recommended for use with the **concrete** foundation.

**Contains:** Corner gussets, perimeter clips, hardware, 1/4" masonry drill bit and installation instruction.

**Anchoring into Concrete:**

1. For poured concrete slab or footing or patio blocks: Use 1/4" x 2" Lag Screws.

2. For Anchor Post of Concrete poured after building is erected: Use 1/4" x 6" Lag Screws.

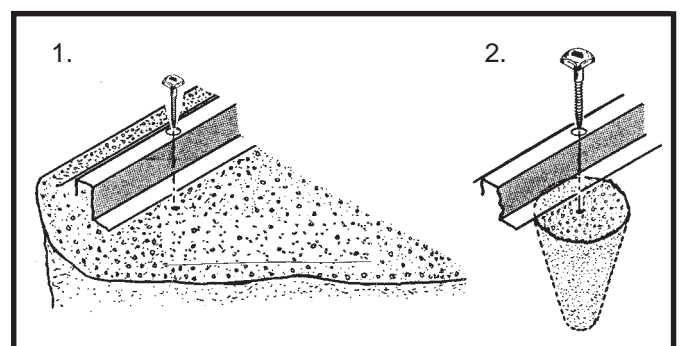
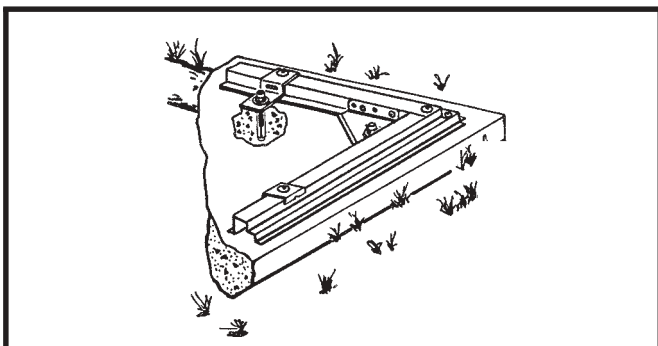

# Hardware

C11

Remove from bag of screws  
and save for the last step



**65103**  
#8-32 Hex Nut (57)



**65900A**  
#10Bx1/2" Black Screw (4)  
(Packed with Screws)



**65923**  
#8-32x3/8" Bolt (57)



**65004**  
#8Ax5/16" Screw (176)

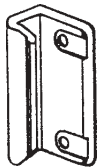

**66045**  
Handle (2)

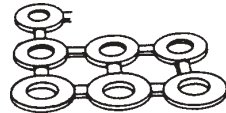

**66646**  
Washer (181)  
(5 sheets of 40)



**65109**  
#8-32 Acorn Nut (6)  
(Packed with Screws)

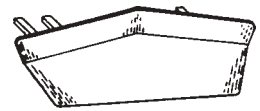

**67468**  
Peak Cap (2)  
(Arrow Logo)

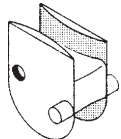

**66242**  
Door Slide (4)

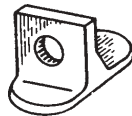

**66382**  
Lower Door Guide (4)

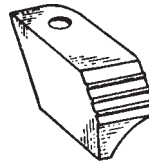

**66183**  
Roof Trim Cap  
(2 right & 2 left)

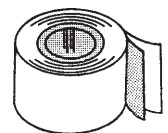

**67293**  
Weather Stripping (1)



**66029**  
Plug (2)  
(Packed with Screws)

# Parts List

012

Assembly Key No.	Part Number	Part Description	Quantity in Carton	Check List
1	5964	Roof Beam	1	
2	5982	Roof Angle	1	
3	5996	Right Gable	2	
4	5997	Left Gable	2	
5	6015	Side Roof Trim	2	
6	6442	Right Roof Panel	2	
7	6443	Left Roof Panel	2	
8	6632	Horizontal Door Brace	4	
9	6657	Door Handle Brace	2	
10	6658	Gable Brace	2	
11	6869	Ridge Cap	1	
12	6515	Wall Panel (Rear)	2	
13	8990	Right Door	1	
14	8989	Left Door	1	
15	7332	Wall Panel (Side)	2	
16	9369	Door Jamb	2	
17	9389	Front Corner Panel	2	
18	9393	Rear Corner Panel	2	
19	9396	Door Track	1	
20	9397	Rear Wall Angle	1	
21	9925	Rear Wall Channel	1	
22	9399	Rear Floor Frame	1	
23	9400	Side Wall Angle	2	
24	9926	Side Wall Channel	2	
25	9402	Side Floor Frame	2	
26	9403	Front Floor Frame	1	

# Assembly by Key No.

C13

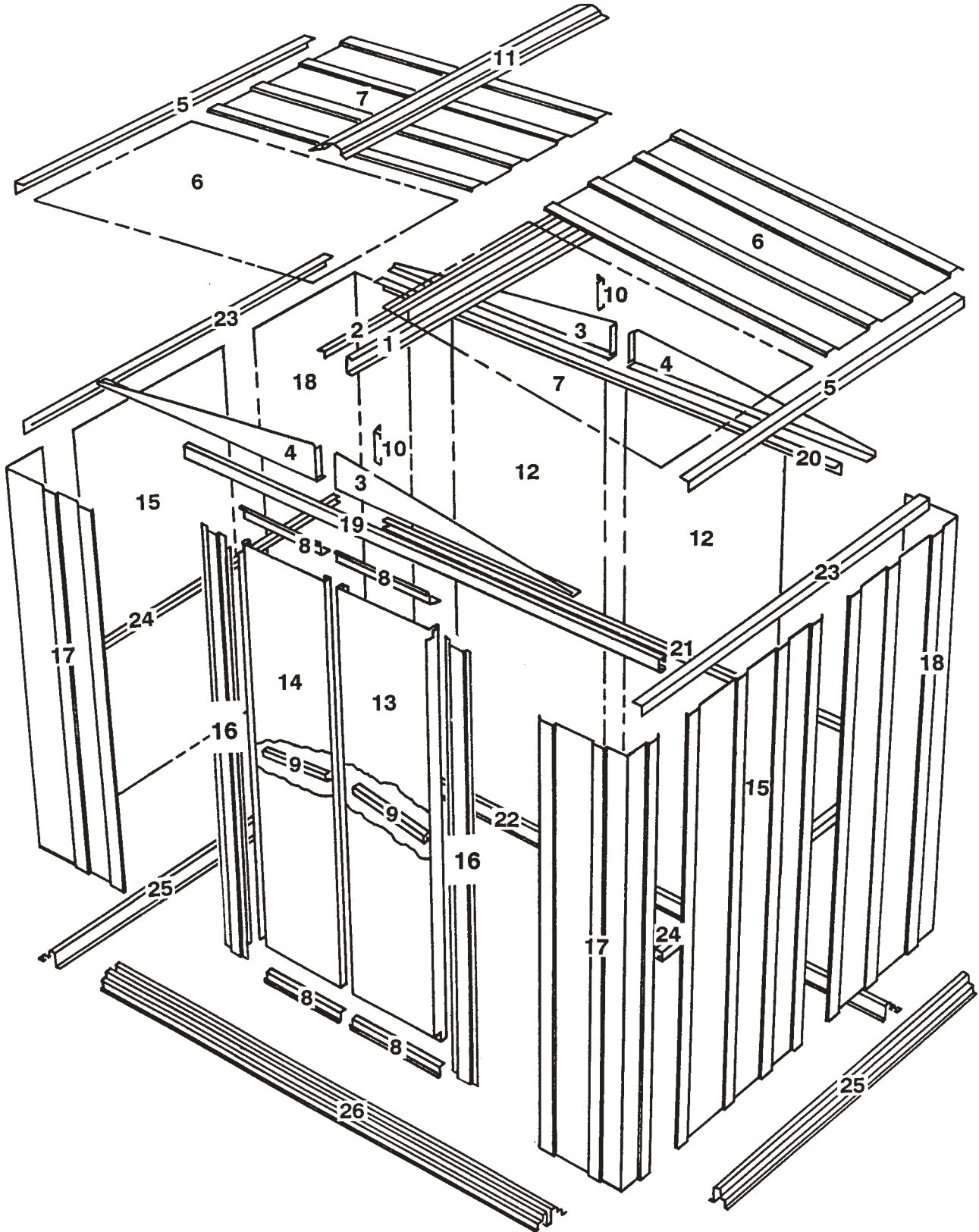

# Step 1

C14

## ● Parts Needed For ● Door Track Assembly

● 9396 Door Track (1)

The door track assembly supports the sliding doors and reinforces the front wall.

**Hint:** The holes in the top side of the door track are for fastening the gable to the top of the front wall in a later step.

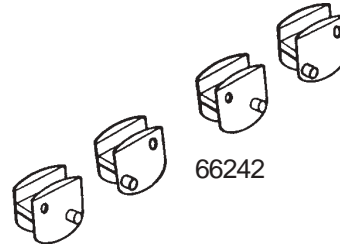

**1** Position **door slides** onto the legs, from the end of door track, as shown in the end view.

NOTE: Flat side on top, pins and holes **must** be oriented as shown.

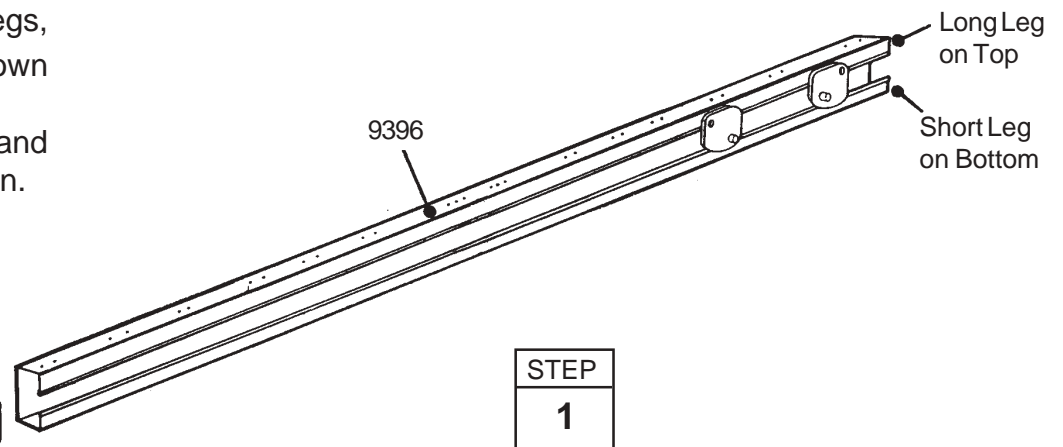
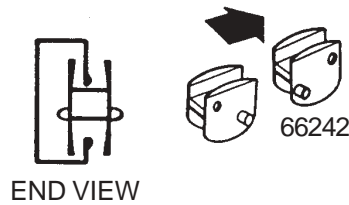

**2** Set this piece aside for later use.

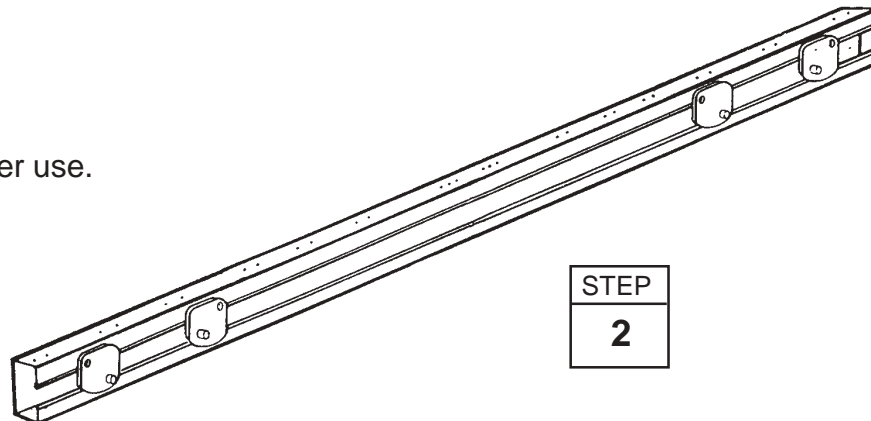

# Step 2

C15

## ● Parts Needed For ● Floor Frame

- 9403 Front Floor Frame (1)
- 9399 Rear Floor Frame (1)
- 9402 Side Floor Frame (2)

**1** Assemble the four corners of the floor frame using two screws at each corner as shown. At the front corners fasten bolts through from the bottom with nuts on top.

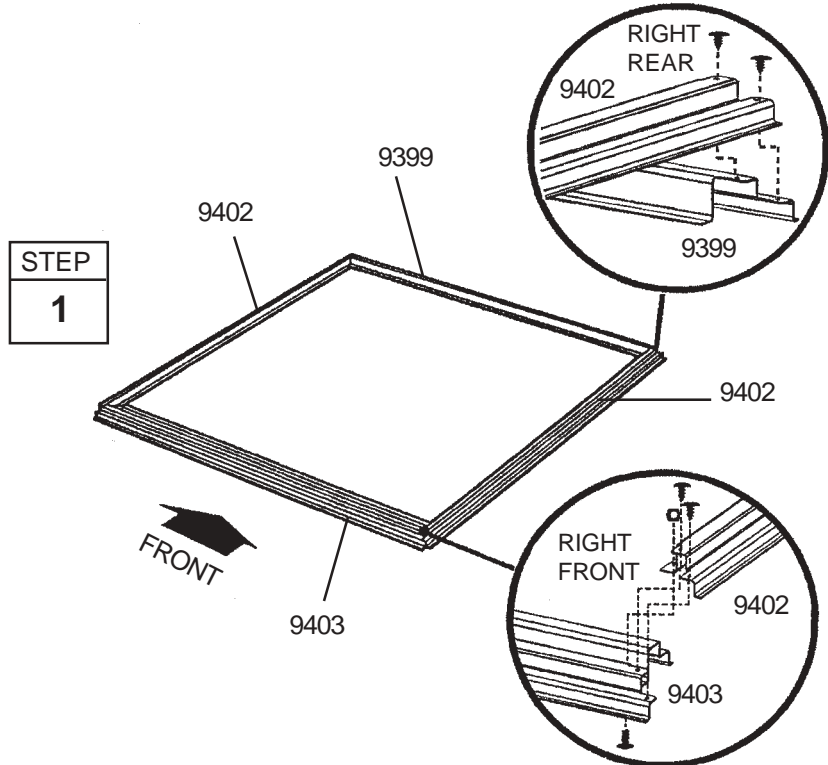

**2** Measure the floor frame diagonally. When the diagonal measurements are equal, the floor frame is square.

### NOTE

If using a wood platform or concrete slab do not fasten the floor frames to your base at this time. You will anchor the building after it is erected.

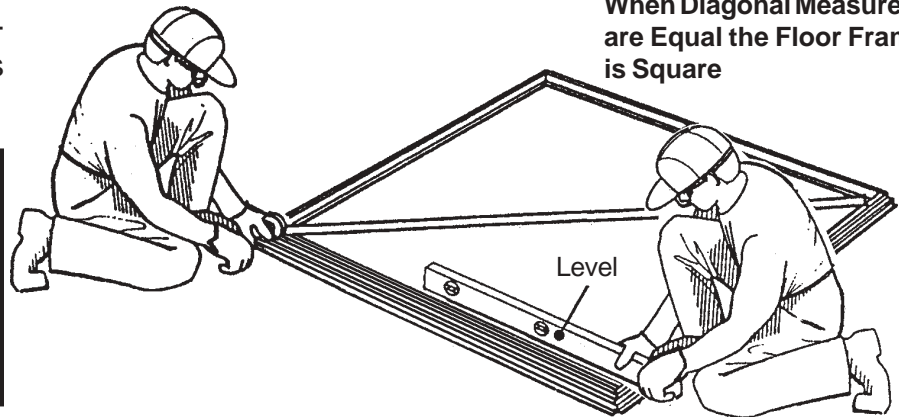

### NOTE

If you have purchased a Floor Frame Kit you need to install it at this time.

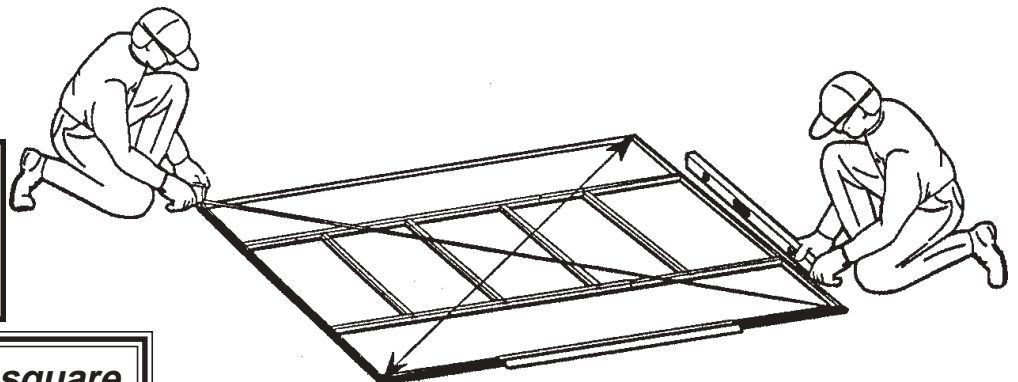

**The floor frame *must be square and level* or holes will not align.**



# Step 3

016

## ● Parts Needed For ● Corners/Wall Panels

- 9389 Front Corner Panel (2)
- 9393 Rear Corner Panel (2)
- 7332 Wall Panel (2)

### NOTE

The remainder of the building assembly requires many hours and more than one person. Do not continue beyond this point if you do not have enough time to complete the assembly today. A partially assembled building can be severely damaged by light winds.

Each screw and bolt in the wall requires a washer.

**1** Position **front corner panels** at the corners of the floor frame as shown. The widest part of each corner panel must be placed at the front of the building. Fasten the corner panels to the floor frame with two screws.

**2** Position **rear corner panels** at rear of building as shown. The widest part of each corner panel must be placed along side of the building. Fasten corner panels to the floor frame using four screws.

### NOTE

The wall panels come in two widths. Each wall panel has a crimped rib on one side. The crimped rib should go under the rib of the panel that follows it.

**3** Attach **wall panels** to the sides, as shown.

### NOTE

Be careful to install the correct panel in each position as shown.

**4** Double-check the part numbers of the wall panels, before proceeding.

**The floor frame *must be square and level* or holes will not align.**

STEP  
2

STEP  
1

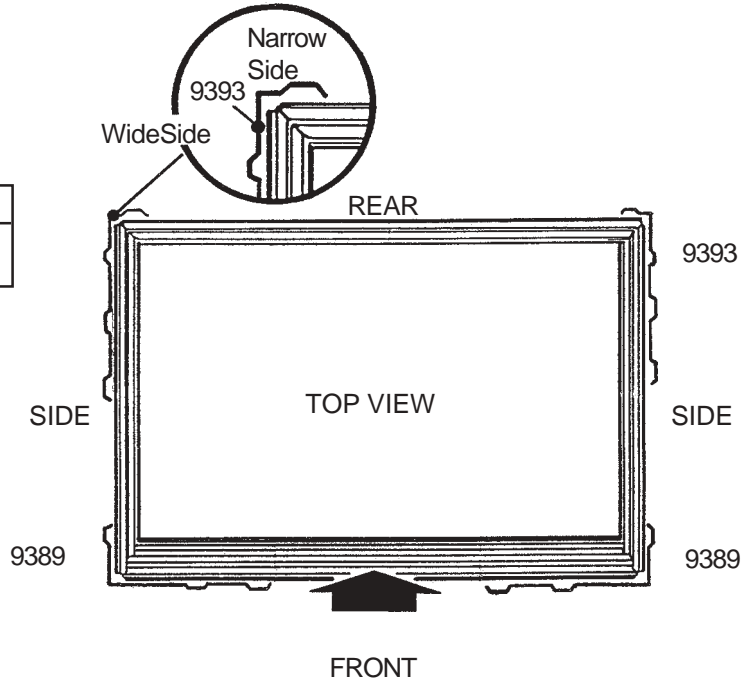

SUPPORT THE CORNER PANEL WITH A STEP LADDER UNTIL A WALL PANEL IS ATTACHED.

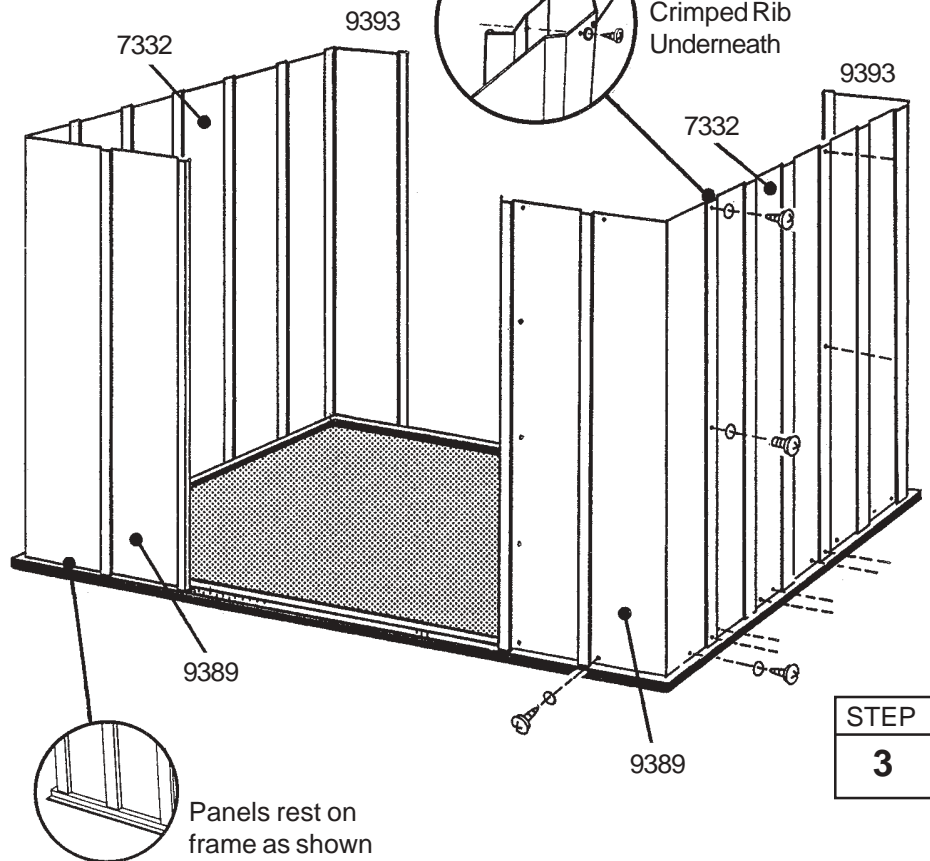

STEP  
3



# Step 4

## ● Parts Needed For ● Frames

- 9397 Rear Wall Angle (1)
- 9925 Rear Wall Channel (1)
- 9926 Side Wall Channel (2)
- 9400 Side Wall Angle (2)
- Door Track Assembly (1)

The main frame pieces give rigidity to the side walls and provide a surface for attaching the gables which support the roof.

**1** Fasten the **rear wall angle** across the inside top of the rear wall using screws.

**2** Fasten the **rear wall channel** across the middle of the rear wall using screws.

**3** Fasten the **side wall angles** across the inside top of the side panels using screws. Side wall angles must overlap rear wall angle in corners.

**4** Fasten the **side wall channels** across the middle of the side panels using screws. Fasten overlaps in rear corners with screws.

**5** Fasten the **door track assembly** (holes on top) across the top of the front wall panels using screws. See the figure.

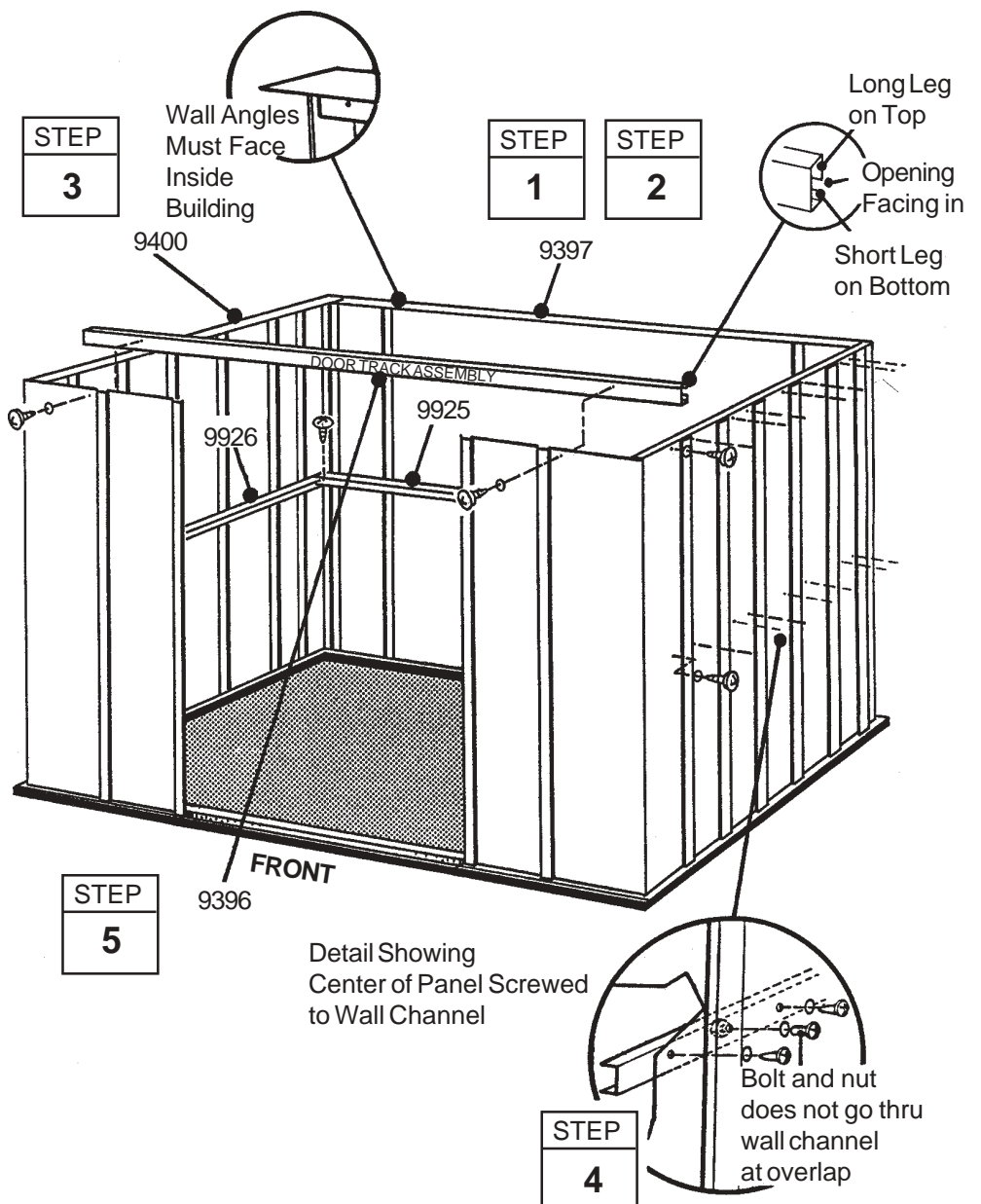

# Step 5

## ● Parts Needed For ● Wall Panels

● 6515 Wall Panel (2)

018

**1** Fasten the **wall panels** at the top and bottom with screws.

**2** Fasten the center of each panel to the wall channel with screws. Fasten overlapping ribs as before.

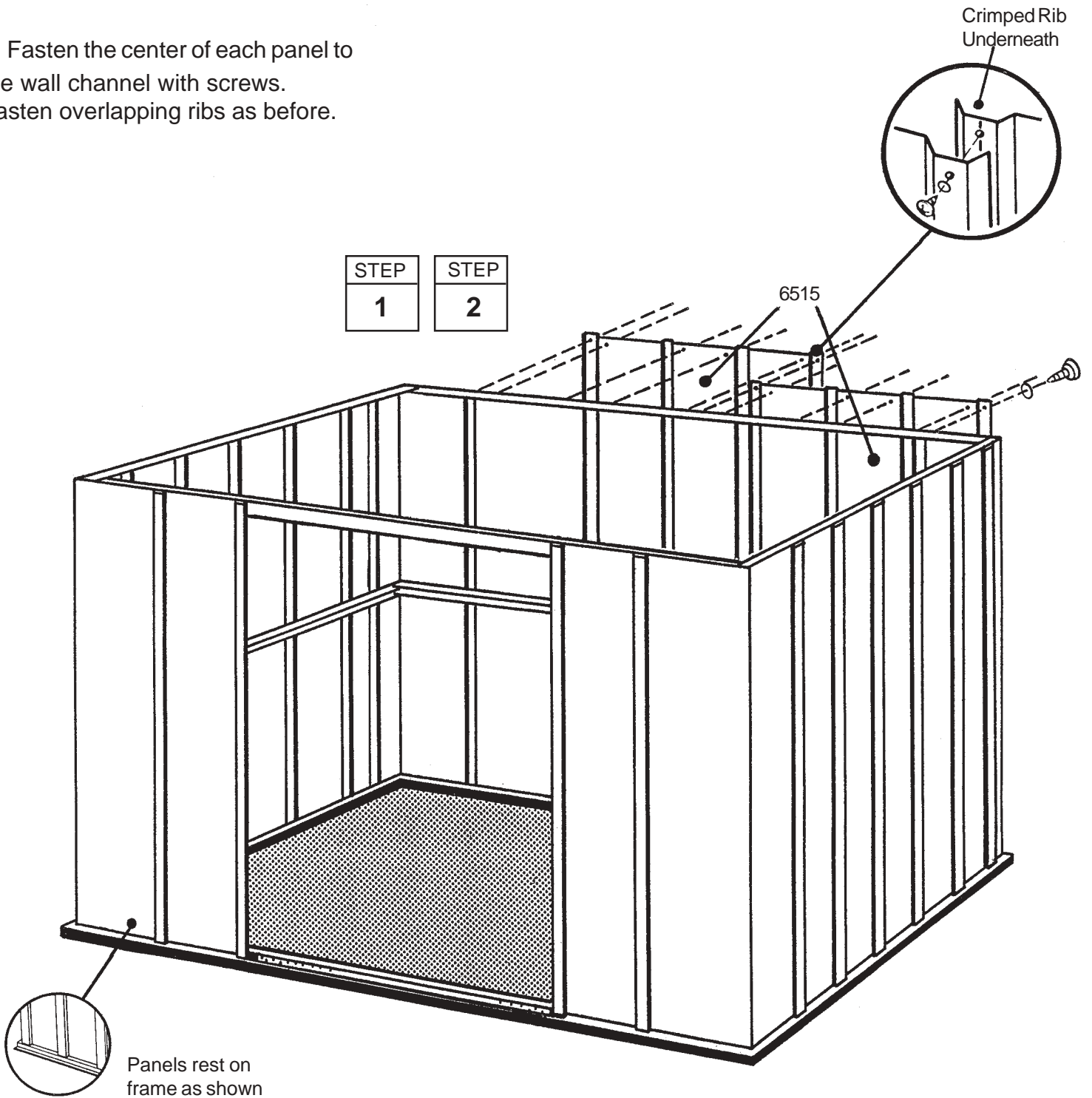

# Step 6

019

## ● Parts Needed For ● Door Jamb

● 9369 Door Jamb (2)

The door jambs reinforce the door opening and provide an attractive trim. Follow these steps for both door jambs.

**1** Fasten a **door jamb** to the front panel with three bolts, nuts and acorn nuts, as shown. Push a **plug** into hole at center of jamb, closest to door opening.

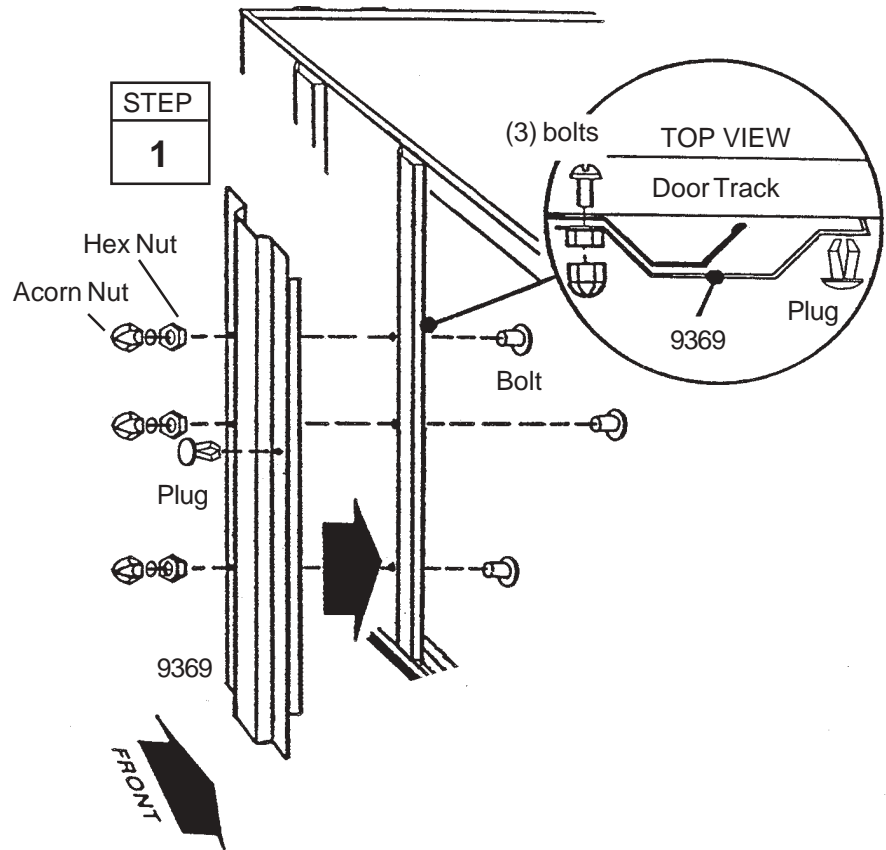

**2** Fasten the top of the door jamb to the door track with two screws. Do the same for the bottom into frame.

Repeat steps 1 and 2 for the *opposite* door jamb.

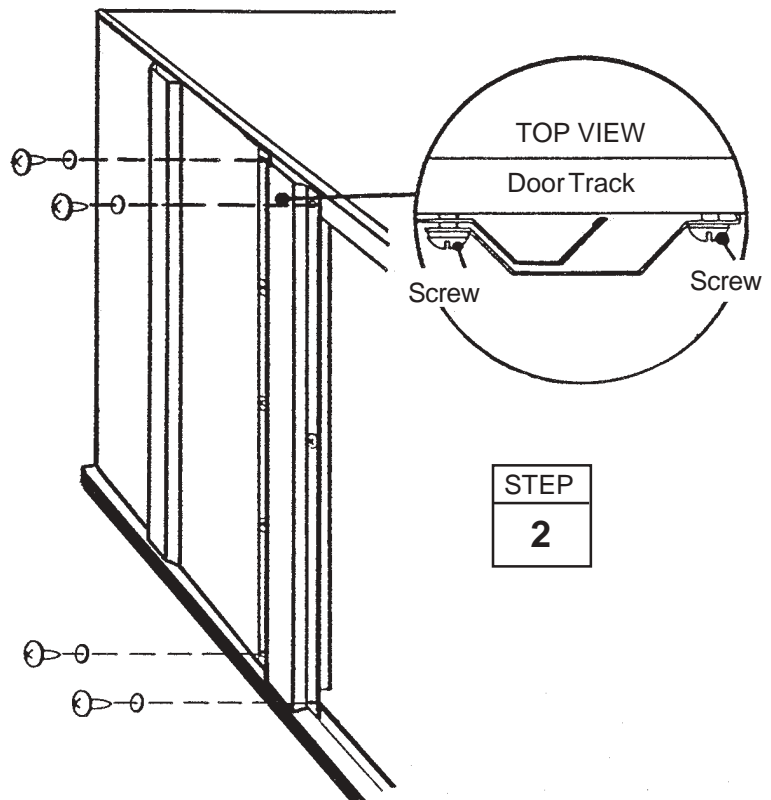

# Step 7

C20

## ● Parts Needed For ● Gables/Braces

- 5996 Right Gable (2)
- 5997 Left Gable (2)
- 6658 Gable Brace (2)

The gables go on top of the front and rear walls to support the roof beam.

### NOTE

The gables are packed nested together and might be mistaken as one piece. Carefully separate them before continuing.

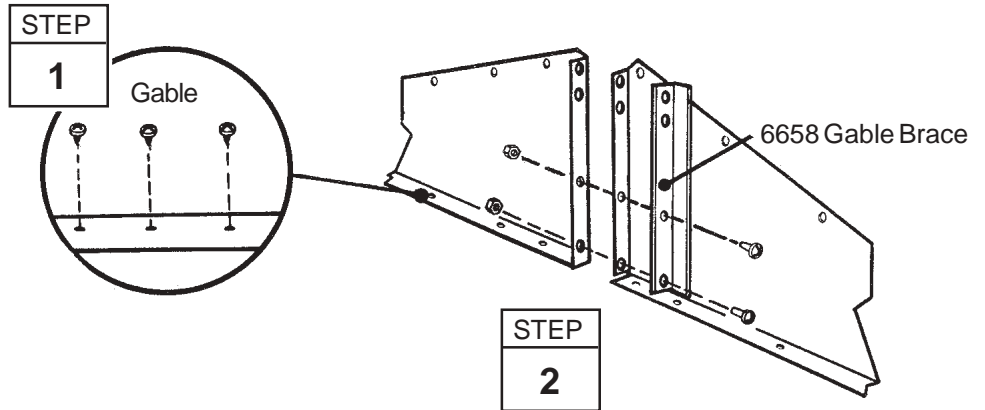

**1** Lift and fasten a right and left gable, under angle at corner, to the door track with screws.

**2** Join the **left** and **right gables** together with a **gable brace** using a bolt in the bottom 2 holes.

Repeat Steps 1 & 2 for the *opposite* side of building.

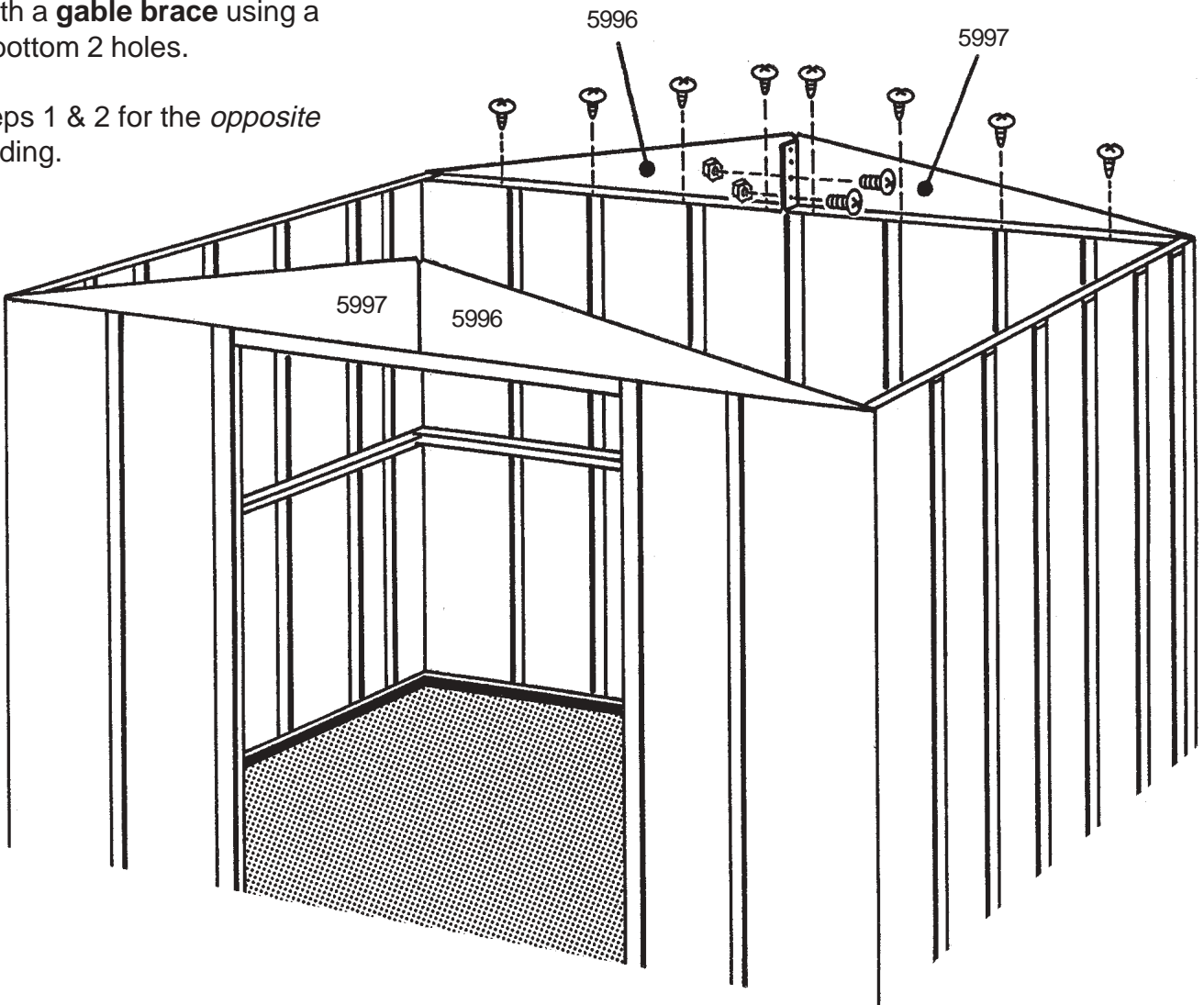

# Step 8

C21

## ● Parts Needed For ● Roof Beam/Angle

- 5964 Roof Beam (1)
- 5982 Roof Angle (1)

**1** Fasten the **roof beam**, *small holes on top*, to the gable brace of the front gable.

**2** Fasten the other end of the roof beam to the gable brace of the rear gable.

**3** Fasten the **roof angle** to the roof beam as shown using screws.

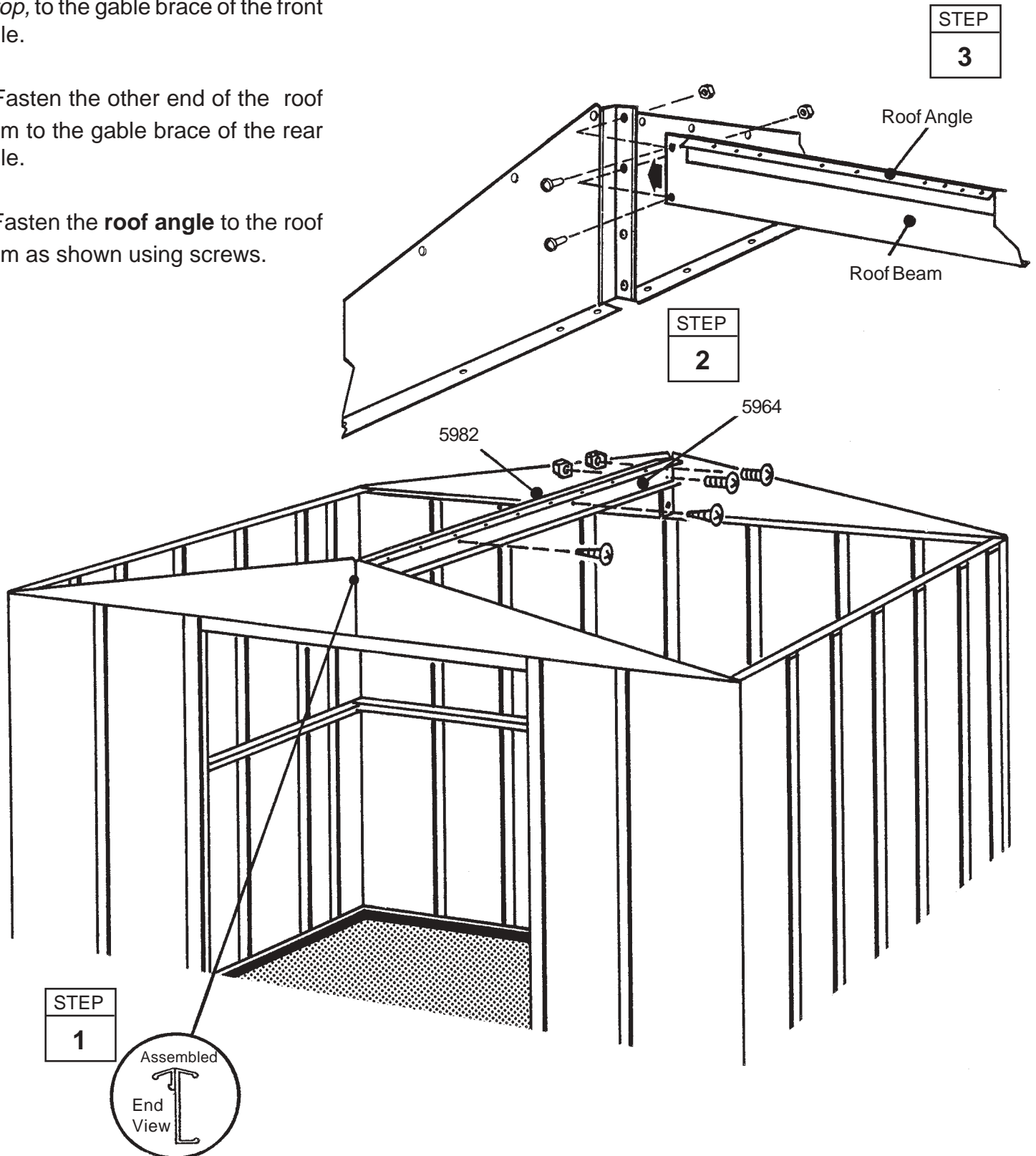

# Step 9

## ● Parts Needed For ● Right Roof Panel

● 6442 Right Roof Panel (1)

C22

Installing the roof panels is best done with a step ladder. Install the first roof panel at the back right corner of the building. Each screw and bolt in the roof requires a washer.

### NOTE

Measure the building diagonally again and make adjustments to make sure the building is square and level. This will make the roof panels fit better, and holes will align. Don't anchor the floor frame.

### NOTE

If a **Roof Beef-Up Kit** was purchased, assemble prior to attaching the roof panels.

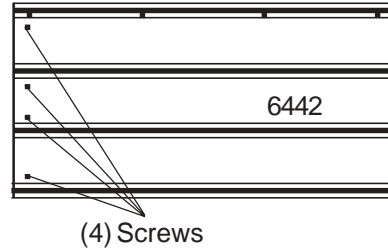

STEP
1

STEP
2

**1** Locate the roof panels and find the **right roof panel** part number 6442.

**2** Position the right roof panel at the back right corner and fasten to the gable with four bolts and nuts and roof beam using four screws. *Do not fasten the lower end of the panel to the side wall angle at this time.*

**Hint:** Attach fasteners in order shown in diagram.

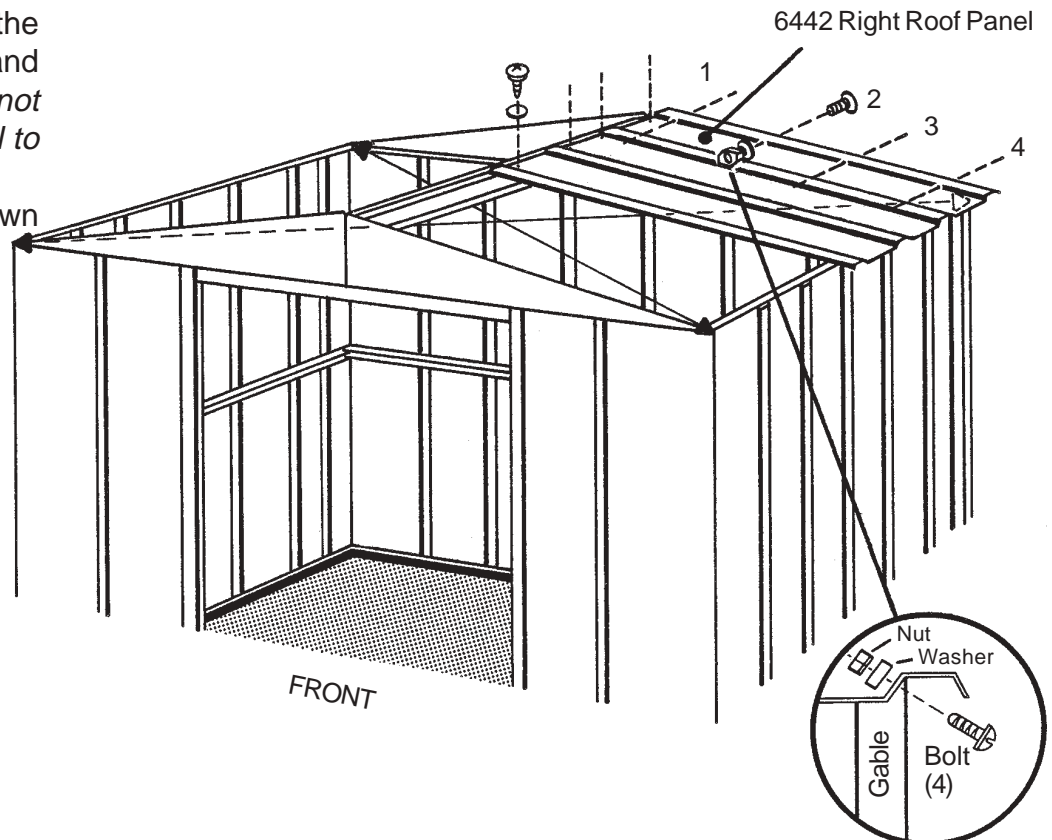

# Step 10

● Parts Needed For ●  
**Left Roof Panel**

● 6443 Left Roof Panel (1)

C23

**1** Install a **left roof panel 6443** at the left rear corner of the roof.

STEP
1

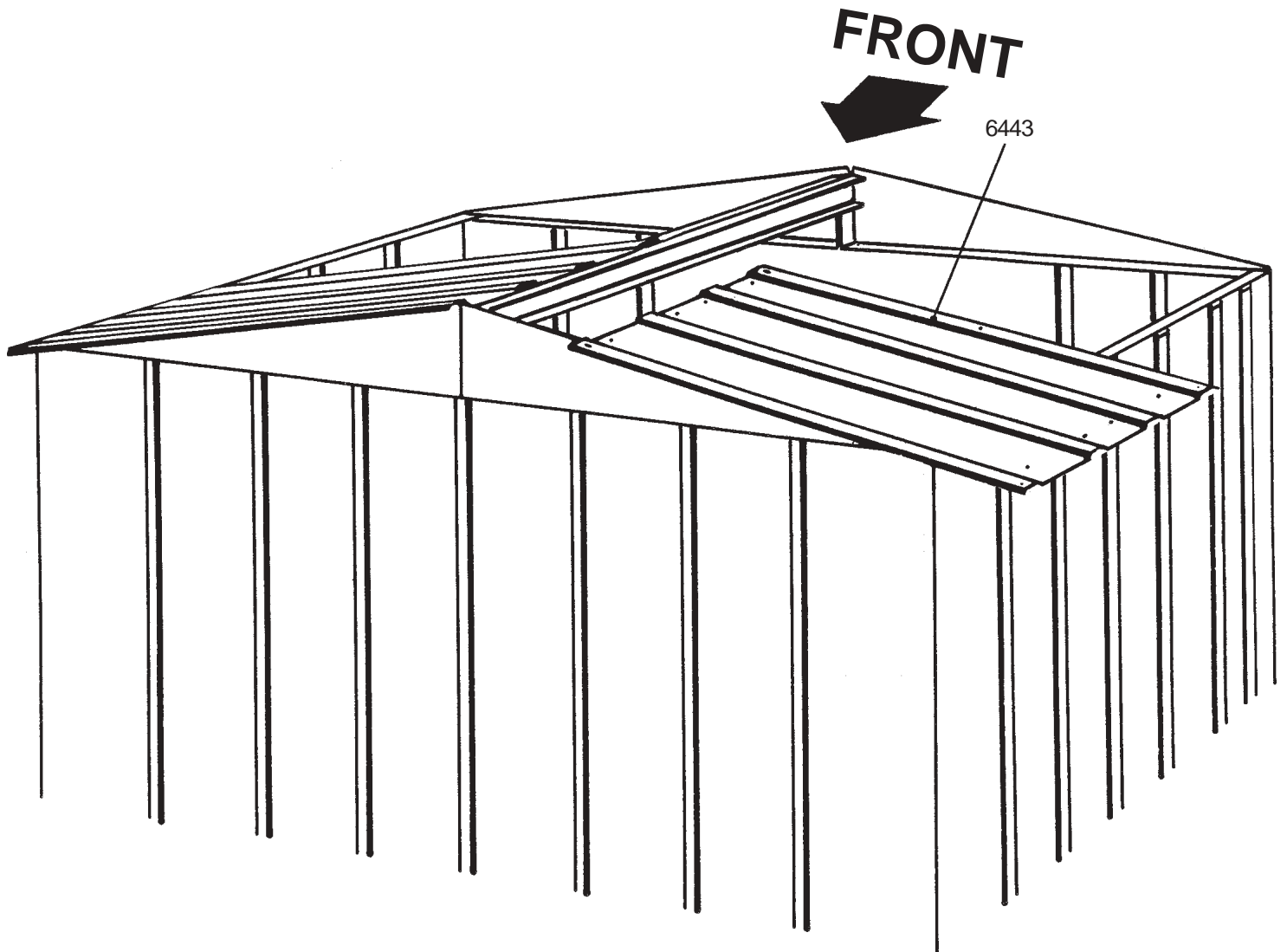



# Step 11

## ● Parts Needed For ● Front of Roof

- 6443 Left Roof Panel (1)
- 6442 Right Roof Panel (1)

C24

**1** Cover the joint at the peak with **weather stripping tape**. Unroll the tape and press it down over the opening at the ridge as you install each roof panel. Do not cut the tape at this time.

**2** Install the **left 6443** and **right roof panel 6442** as you unroll the weather stripping tape, and press it down. Fasten overlap at center of roof panel rib using a bolt and nut.

### NOTE

Narrow roof panel crimped rib is overlapped by wide rib of adjacent panel where possible

**3** Unroll the weather stripping tape, press it down firmly, and cut it.

**4** Fasten the lower end of the panels to the side wall angles using screws and washers.

### NOTE

If roof beam holes do not line up with the roof panel holes, shift the building from left to right. If this does not help, your building may not be level. Shim the corners until holes line up.

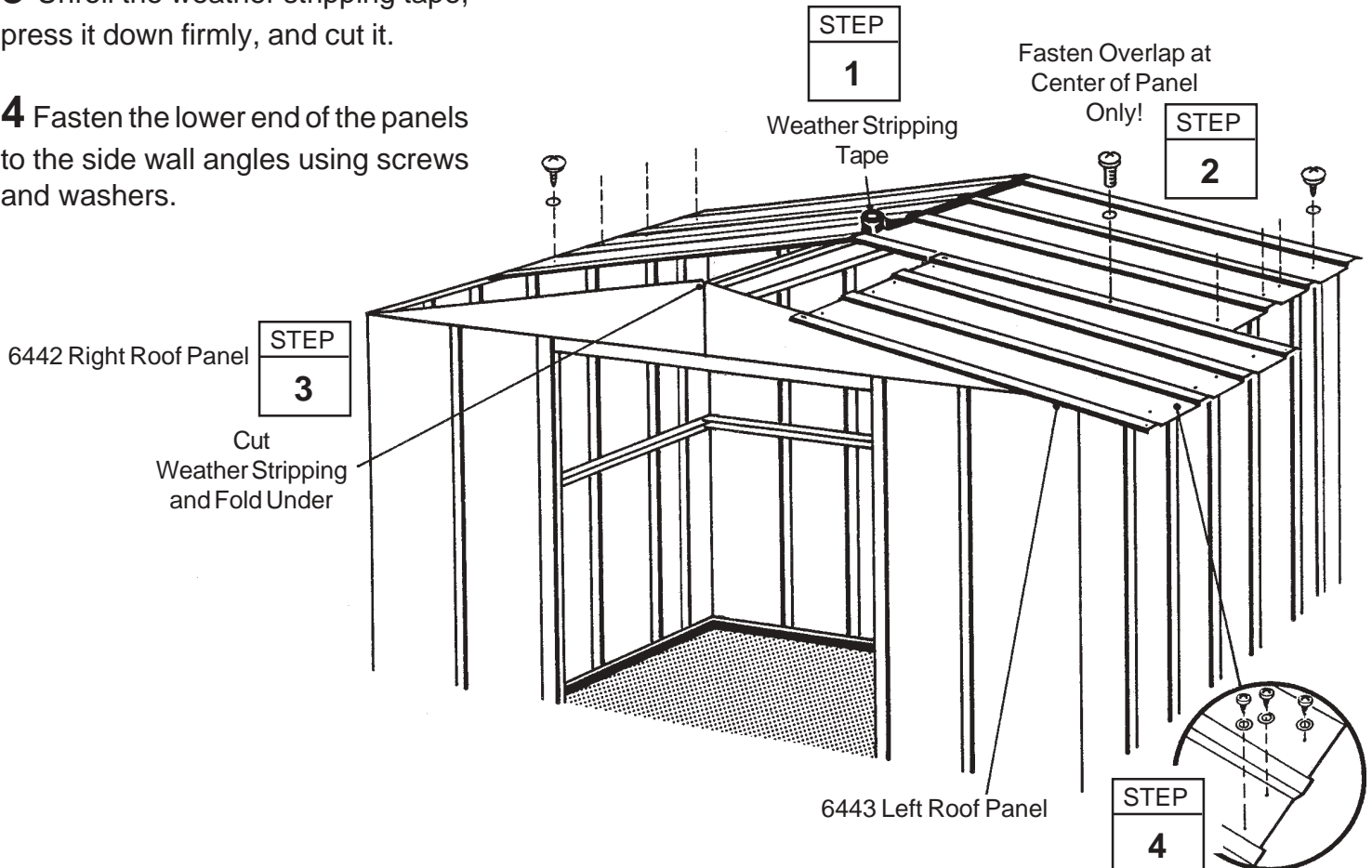



# Step 12

## ● Parts Needed For ● Ridge Cap/Roof Trim

- 6869 Ridge Cap (1)
- 6015 Side Roof Trim (2)

C25

**1** Install the **ridge cap** on the completed roof section using bolts and nuts.

**2** Fasten the roof panel ribs, **peak cap** and ridge cap together using bolts and nuts. Fasten the remaining peak cap in the same manner.

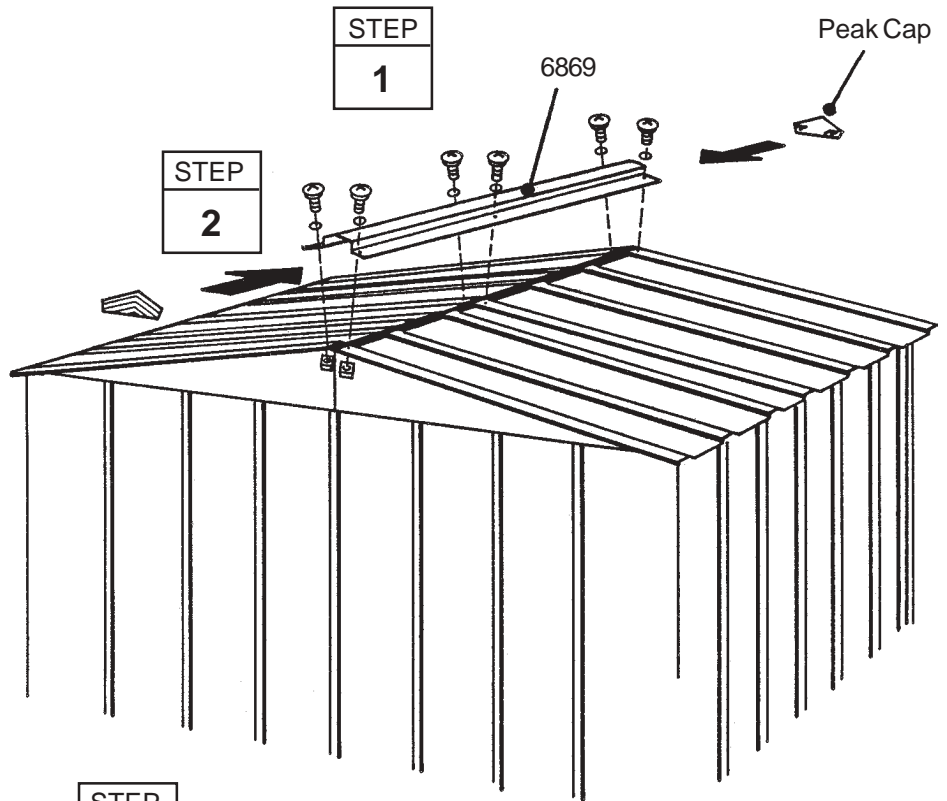

**3** Attach the **side roof trim** to the lower end of roof panels on each side of the building using screws at each panel overlap.

**4** Using your thumb and index finger, overbend the bottom flange of the roof panel rib at the corner inward enough so the right and left roof trim caps fit onto right and left corners.

**5** Fasten the roof trim caps to the side trim using a screw.

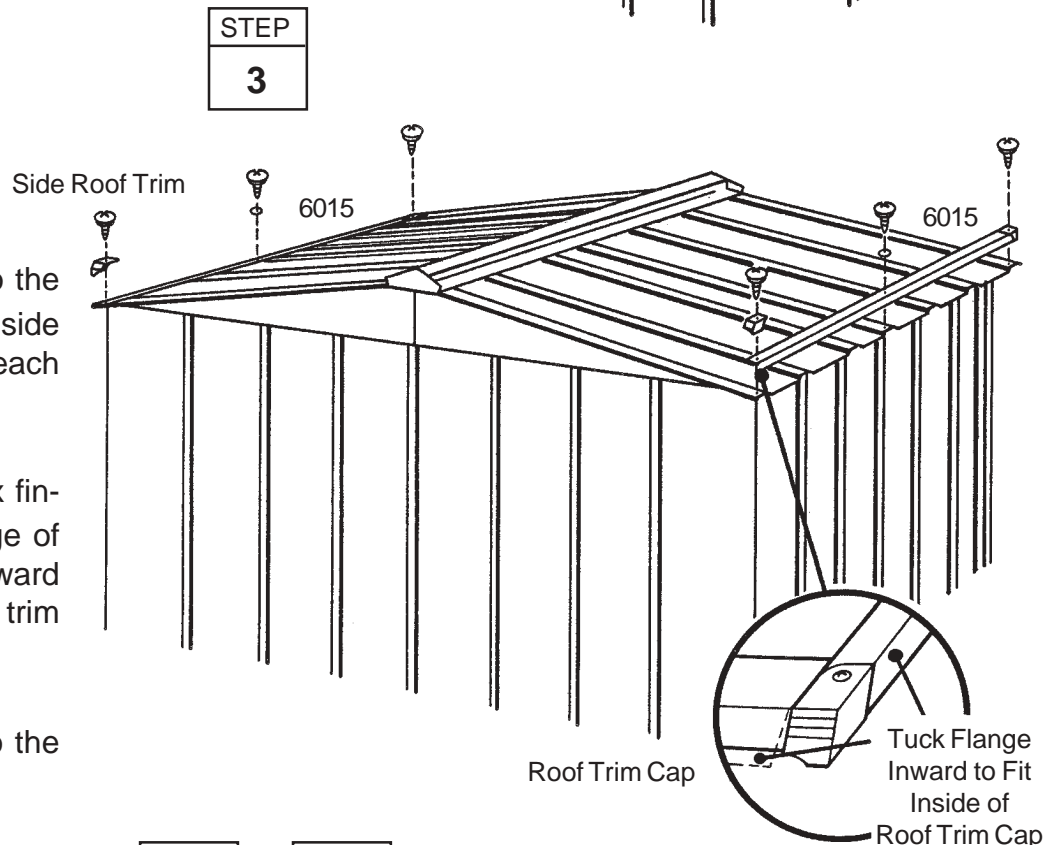

STEP  
4

STEP  
5

# Step 13

## ● Parts Needed For ● Door Assembly

- 6657 Door Handle Brace (2)
- 8990 Right Door (1)
- 8989 Left Door (1)
- 6632 Horizontal Door Brace (4)

The steps on this page tell how to assemble the right door. You will perform exactly the same procedures for the left door. Each screw and bolt in the door requires a washer. Proceed as follows:

**1** Attach the **door handle brace** and **handle** to the **door** with 1 bolt as shown. *Don't tighten the bolt yet.*

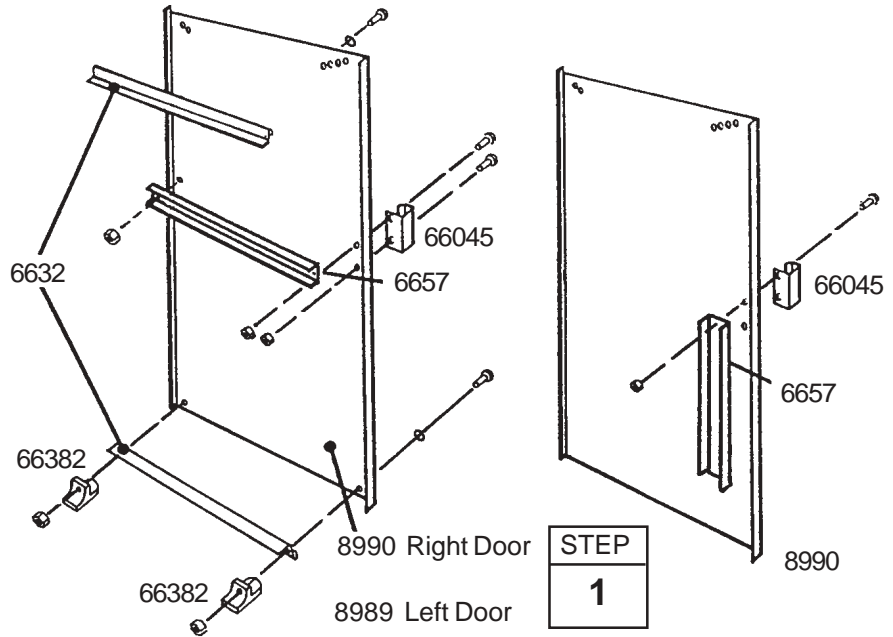

**2** Swing the door handle brace up to the hole on the opposite side of the door and insert a bolt and nut.

**3** Insert a second bolt in the door handle and tighten both bolts.

**4** Put a **horizontal door brace** onto the top edge *and* bottom edge.

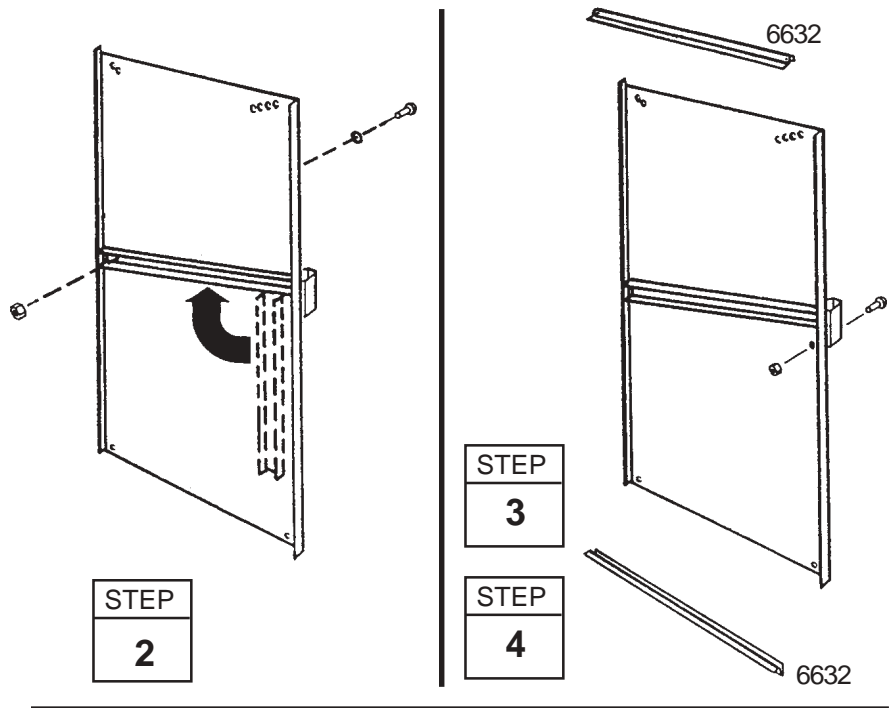

**5** Attach the **lower door guides** as shown.

**6** Repeat steps 1 through 5 for the **left door**.

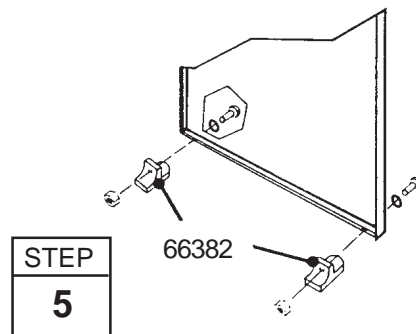

END VIEW  
SHOWING:

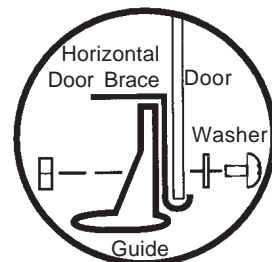

# Step 14

## ● Parts Needed For ● Door Installation & Adjustment

- Right Door Assembly (1)
- Left Door Assembly (1)

C27

**1** From inside the building, put the bottom of the right door assembly (on your left when you are inside the building) behind door jamb into the front frame track.

**2** Position the top of the door so that that holes in the door line up with the holes in the door slides.

**3** Fasten the door to the door slides using a #10Bx1/2" screw.

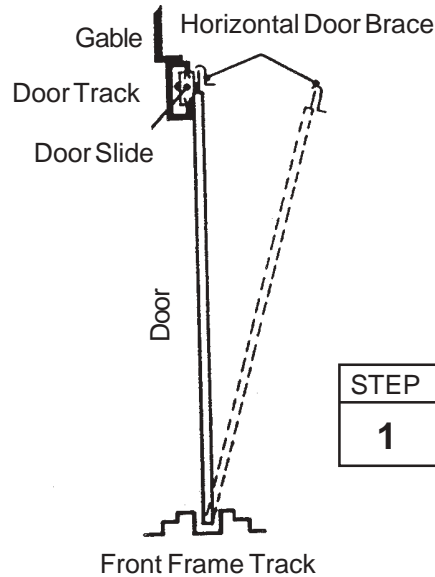

**NOTE**  
The four holes in the top of each door allow you to adjust the doors. Place the door slide in the middle 2 holes.

**4** Repeat steps 1 through 3 for the left door.

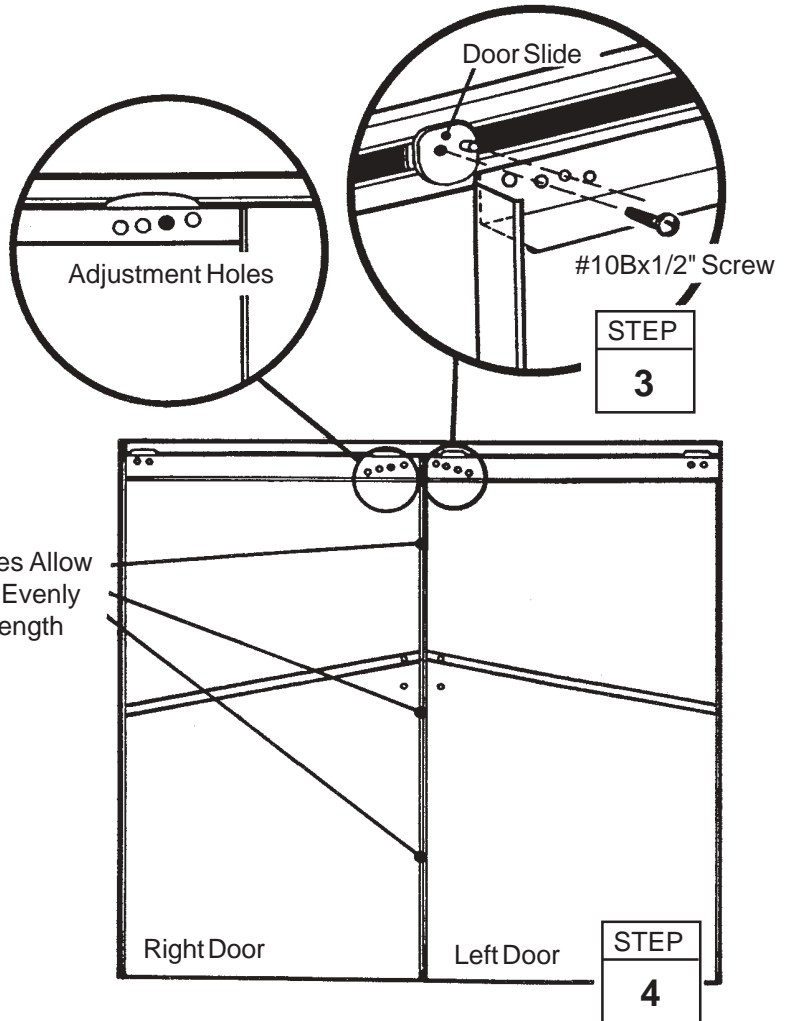

**SOME FACTS ABOUT RUST**

Rusting is a natural oxidizing process that occurs when bare metal is exposed to moisture. Problem areas include screw holes, unfinished edges, or where scrapes and nicks occur in the protective coating through normal assembly, handling and use. Identifying these natural rusting problem areas and taking some simple rust protection precautions can help to stop rust from developing, or stop it quickly as soon as it appears.

1. Avoid nicking or scraping the coating surface, inside and out.
2. Use all the washers supplied. In addition to protecting against weather infiltration, the washers protect the metal from being scraped by the screws.
3. Keep roof, base perimeter and door tracks free of debris and leaves which may accumulate and retain moisture. These can do double damage since they give off acid as they decay.
4. Touch up scrapes or nicks and any area of visible rust as soon as possible. Make sure the surface is free of moisture, oils, dirt or grime and then apply an even film of high quality touch-up paint.