



OWNER'S MANUAL
**FOLD DOWN
WORKSTATION**

MFS3219B

www.montezumastorage.com

LIFE ORGANIZED

Montezuma is committed to helping you succeed in both your work and personal life by being organized, prepared and equipped with the right tools, gear and home supplies at your finger tips.

We are here to ensure that your life is organized.

Thank you for your purchase of this Montezuma Fold Down Workstation.

ATTENTION

TO REDUCE THE RISK OF INJURY, THE USER MUST READ AND UNDERSTAND THIS INSTRUCTION MANUAL BEFORE USING THIS PRODUCT FOR THE FIRST TIME. SAVE THESE INSTRUCTIONS FOR FUTURE REFERENCE.

Fill in the following information and retain this owner's manual for future reference:

MODEL(S):

DATE OF PURCHASE:

PLACE OF PURCHASE:

RECEIPT NO:

SPECIFICATIONS

MAXIMUM PRODUCT WEIGHT (INCLUDING CONTENTS): 200 lb (90.7 kg) of evenly distributed weight.

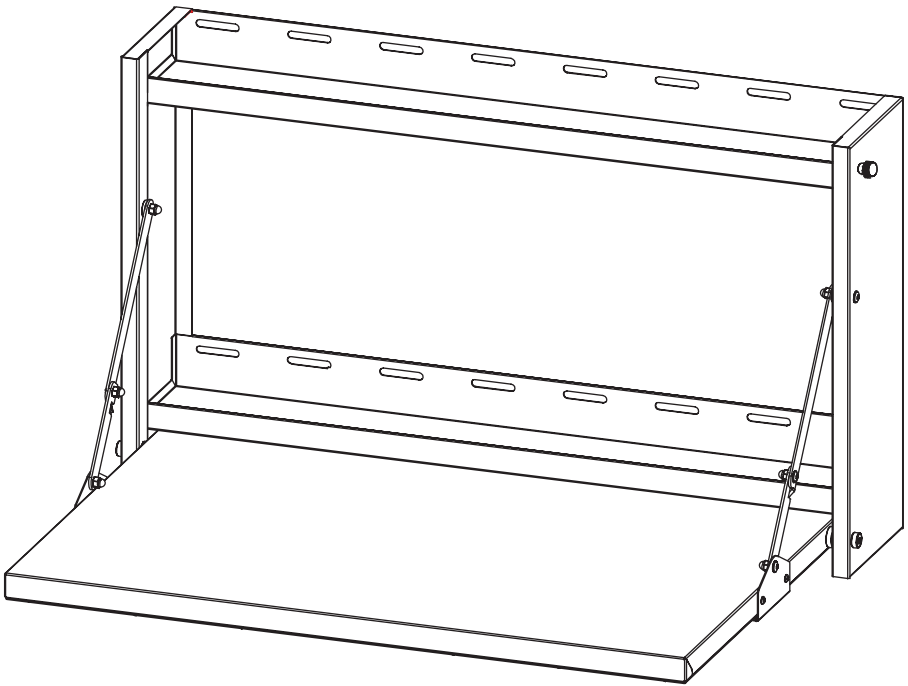

MAINTENANCE

Periodically clean the surfaces with mild detergent and water.

Grease and oil can be removed with most standard cleaning fluids. For safety, use a nonflammable cleaning fluid.

Regularly check the fastening hardware to make sure the workstation is securely installed on the wall.

SAFETY

This product is not recommended for outdoor use.

Make sure all fastening hardware is tightly fastened before using the workstation.

Do not allow children to use this product without supervision. Do not allow children to climb or play on this product.

Do not stand, sit or climb on this product, or use it to pull yourself up.

Ensure the workstation is clear of all items that could interfere with its closing prior to raising the worksurface.

Secure the locking pin when closing the worksurface. Do not assume it has clicked into place.

Do not exceed the maximum weight limit described in this manual. Excessive weight can cause instability and result in injury.

Do not make any modifications to the product.

Secure the workstation properly into at least two wooden wall studs before use. The workstation must be anchored to 2" wooden studs to perform correctly and support the rated weight capacity. Do not use only anchors to secure the workstation – it must be mounted into wooden studs. There are multiple mounting holes in the workstation that will allow for adjustment to hit multiple wooden studs.

PARTS LIST

1

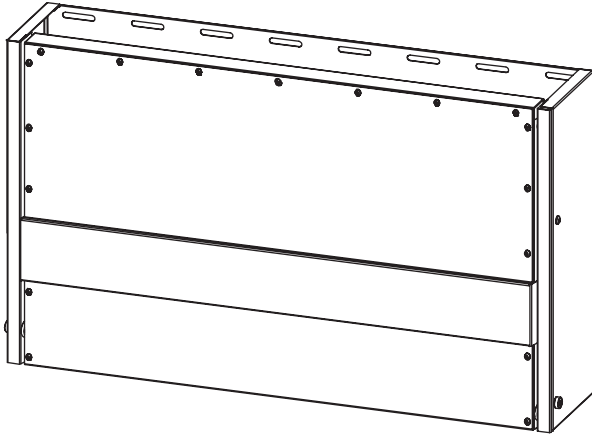

Workstation

6

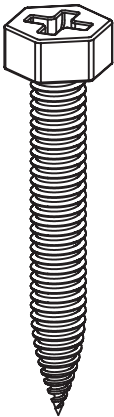

Lag Screw

6



Washer

2

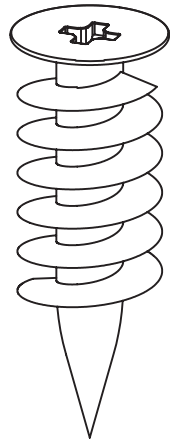

Anchor

NOTE: If the wall you are mounting the workstation to has a different construction than 16" on center wood framed/support walls, please contact your local hardware store for the appropriate fastening hardware.

INSTALLATION

WARNING: TWO PEOPLE ARE REQUIRED TO INSTALL THE WORKSTATION ON THE WALL.

NOTE: There are obround holes along the back of the top and bottom shelves. We recommend securing the workstation in six locations – three locations at the top of each shelf.

HINT: It may be easier to attach a cleat to the wall to help hold the workstation on the wall while you mark the fastening holes. Use two people – one to hold the workstation in place and the other to mark the holes.

Determine and mark the desired height of the workstation on the wall with a pencil. Make sure that the worksurface will be at the desired height when it is open.

Use a stud finder to find the wooden stud locations in the wall you will be mounting the fold down workstation. Mark their locations with a pencil.

Use these stud locations to mark six holes for fastening the workstation to the wall, three in the top shelf and three in the bottom shelf. We recommend that the workstation be secured to a wall stud at one end and in the fifth holes from that end. The other end without the wall stud can be secured using an anchor.

Draw a line at the top of the workstation. Remove the workstation and place a level along the line you have drawn to make sure the workstation will be level.

Pre-drill holes at the locations you have marked.

While one person holds the workstation in place (again, having a cleat on the wall would help stabilize the installation process), the other person should secure the workstation to the wall using the hardware provided. Use a lag screw and washer for securing to wall studs. Add an anchor when not securing to a wall stud. Tighten securely.

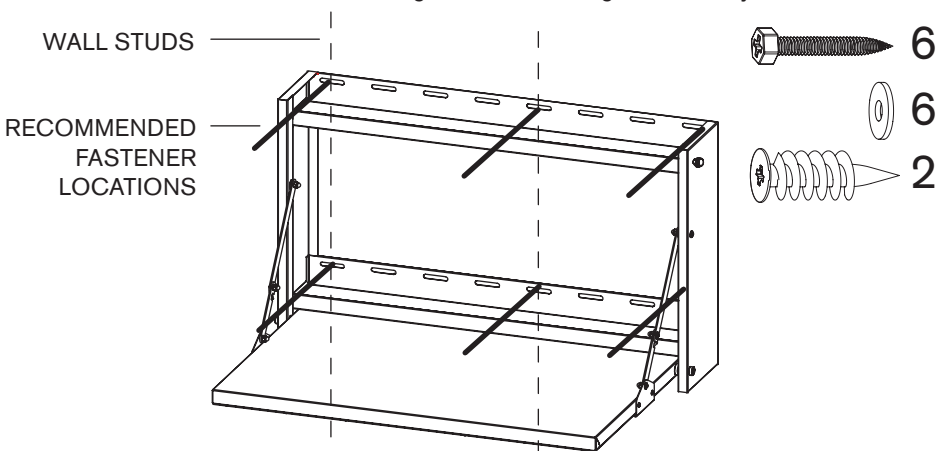



This product is warranted to be free from defects in materials and workmanship for a period of one (1) year from the date of original purchase.

If this product is defective, email service@montezumastorage.com or call 1-800-459-4409 (Monday–Friday, 8:00 am–4:30 pm, CST). If the product is defective, we will replace the defective part at no cost to you. Please do not ship your product back to the store or to us unless we send you written instructions for return.

In the event it becomes necessary for your product to be returned, we will notify you how to proceed. A copy of your original purchase receipt must accompany the returned product.



WARNING

Cancer and Reproductive Harm – www.P65Warnings.ca.gov



Manufactured by:

QUALITY CRAFT

Romeoville, IL, USA 60446

service@montezumastorage.com

1-800-459-4409

(Monday to Friday, 8:00 am–4:30 pm, CST)

Made in China