

Montezuma[®]
LIFE ORGANIZED

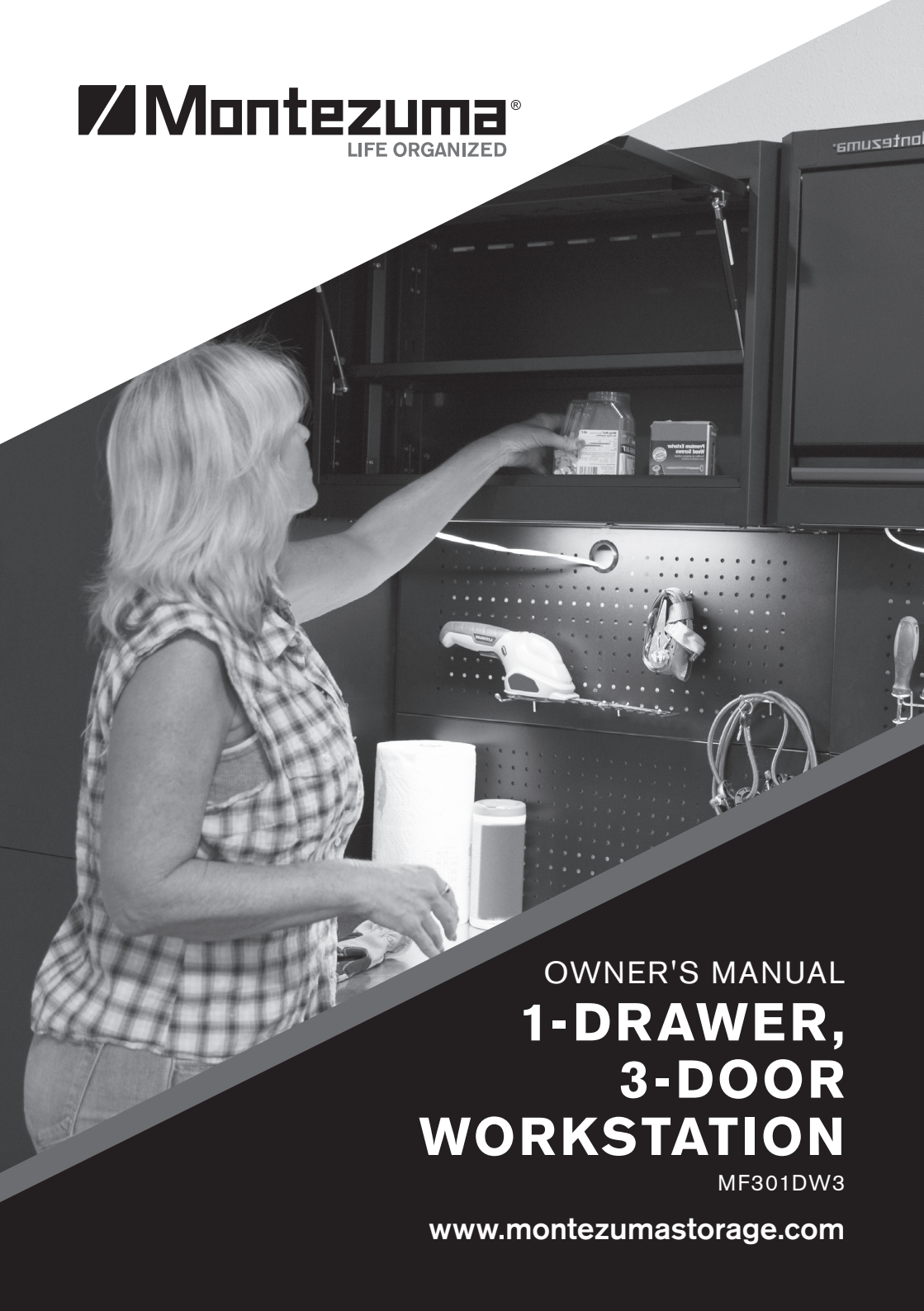

OWNER'S MANUAL
**1-DRAWER,
3-DOOR
WORKSTATION**

MF301DW3

www.montezumastorage.com

LIFE ORGANIZED

Montezuma is committed to helping you succeed in both your work and personal life by being organized, prepared and equipped with the right tools, gear and home supplies at your finger tips.

We are here to ensure that your life is organized.

Thank you for your purchase of this Montezuma 1-Drawer, 3-Door Workstation.

ATTENTION

TO REDUCE THE RISK OF INJURY, THE USER MUST READ AND UNDERSTAND THIS INSTRUCTION MANUAL BEFORE USING THIS PRODUCT FOR THE FIRST TIME. SAVE THESE INSTRUCTIONS FOR FUTURE REFERENCE.

Fill in the following information and retain this owner's manual for future reference:

MODEL(S):

DATE OF PURCHASE:

PLACE OF PURCHASE:

RECEIPT NO:

SPECIFICATIONS

OVERALL DIMENSIONS:

77.6 cm W x 49 cm D x 206.6 cm H
(30-1/2" W x 19-1/4" D x 81-3/8" H)

1 x 1-DOOR WALL CABINET

DIMENSIONS:

77.6 cm W x 30.5 cm D x 51 cm H
(30-1/2" W x 12" D x 20" H)

MAXIMUM SHELF WEIGHT:

23 kg (50 lb)

2 x PEGBOARD PIECES

DIMENSIONS:

77.6 cm W x 32 cm D x 2.2 cm H
(30-1/2" W x 12-5/8" D x 7/8" H)

MAXIMUM WEIGHT CAPACITY: 23 kg (50 lb)

* per each pegboard

2 x POSTS

DIMENSIONS:

5.5 cm W x 3.1 cm D x 166.1 cm H
(2-1/8" W x 1-1/4" D x 65-3/8" H)

1 x 1-DRAWER, 2-DOOR BASE CABINET

DIMENSIONS:

77.6 cm W x 46 cm D x 87.9 cm H
(30-1/2" W x 18-1/8" D x 34-5/8" H)

MAXIMUM DRAWER WEIGHT:

32 kg (70 lb)

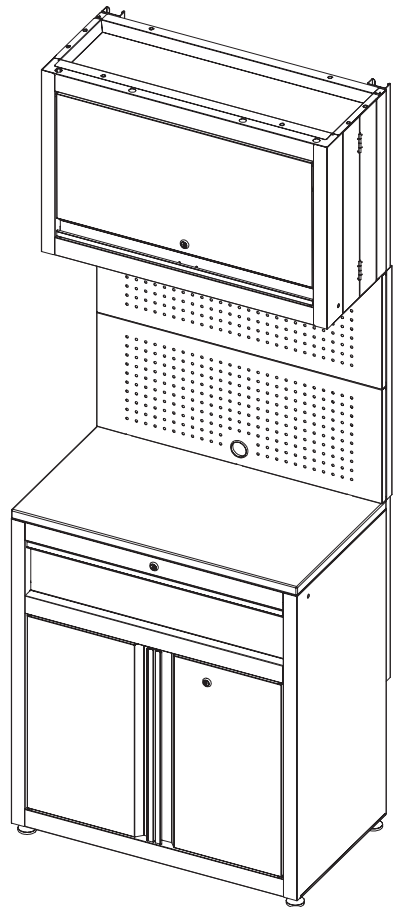

* Dimensions do not include adjustable feet.

PARTS LIST



The keys are taped inside the cabinets.

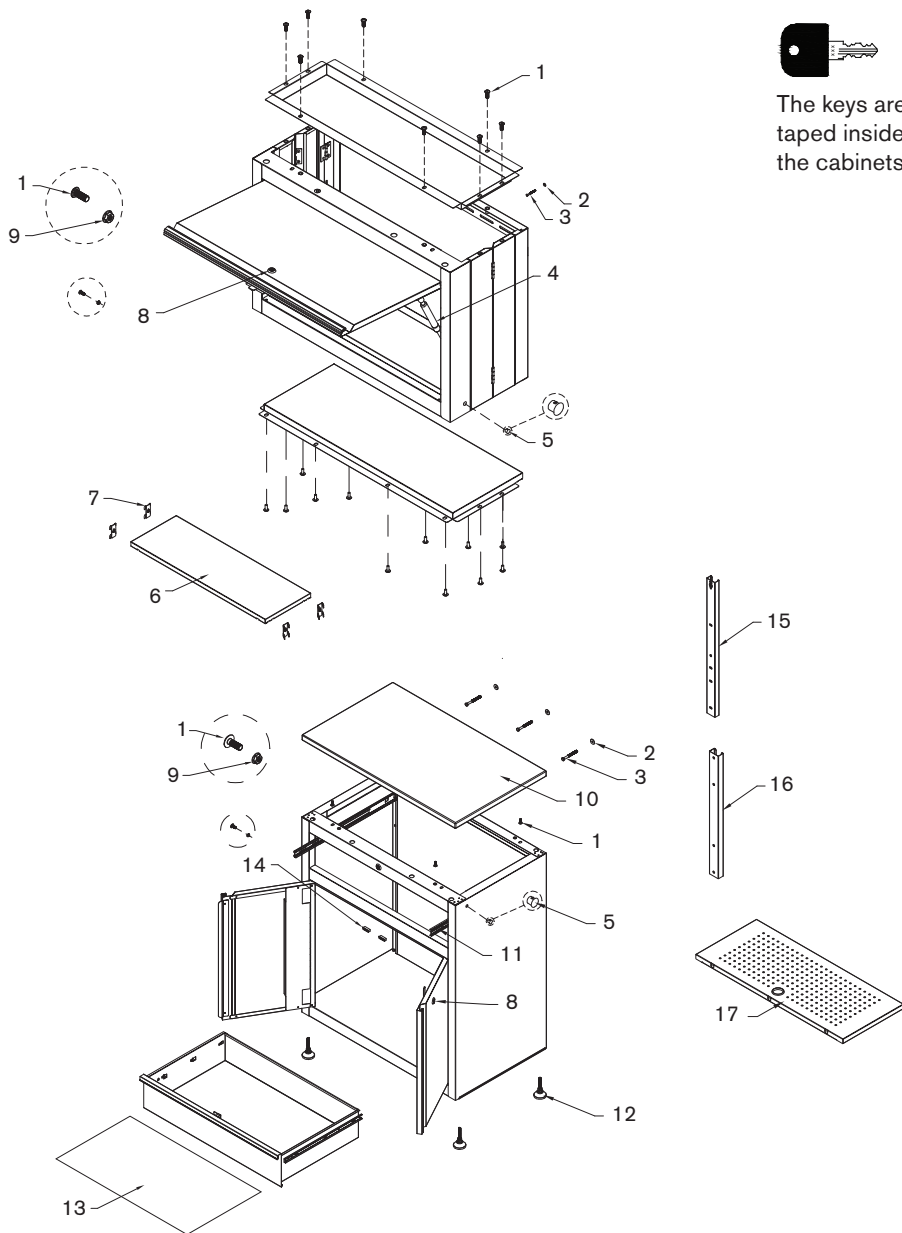

REF	DESCRIPTION	PART NUMBER	QTY
1	M6 x 16 mm Hex Socket Head Screw	320327	43
2	Washer	324050	6
3	M6 x 65 mm Hex Tapping Screw	320316	6
4	Gas Strut	303002	2
5	End Cover	314195	4
6	Shelf	233955	1
7	Shelf Support	226078	4
8	Lock and Key (001)	304178	3
9	M6 Hex Flange Nut	323085	2
10	Worktop	571406	1
11	Slide Set	300029–300030	1
12	Adjustable Feet	110068	4
13	Drawer Liner	552161	1
14	Magnet	312033	2
15	Post A	226911	4
16	Post B	240368	2
17	Pegboard	226913	2

To order replacement parts, email service@montezumastorage.com or call 1-800-459-4409 (Monday–Friday, 8:00 am–4:30 pm, CST). Have the part number and quantity ready. Replacement keys may be ordered using the code that appears on the face of the lock. Not all parts are covered under warranty. Those parts not covered can be purchased.

43

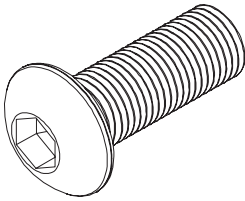

M6 x 16 mm Hex Socket Head Screw

- 8 for attaching top panel of wall cabinet
- 11 for attaching bottom panel of wall cabinet
- 4 for attached worktop to base cabinet (pre-installed)
- 18 for attaching pegboards and wall cabinet to posts
- 2 for attaching unit to other units

6



Washer

For use with M6 x 65 mm Hex Tapping Screw

6

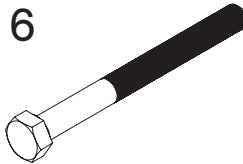

M6 x 65 mm Hex Tapping Screw

For securing unit to the wall

2

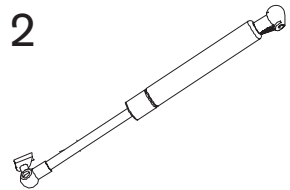

Gas Strut

Pre-installed
For opening door

4



End Cover

For covering holes for attaching to other units, if not in use

1

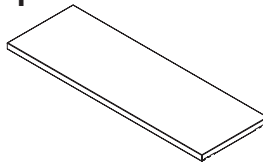

Shelf

For placing at desired height

4

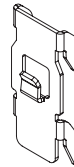

Shelf Support

For supporting adjustable shelf

3



Lock and Key

For securing your valuables

2



M6 Hex Flange Nut

For use with M6 x 16 mm Hex Socket Head Screw when attaching unit to other units

1

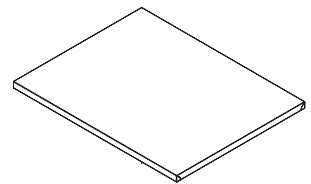

Worktop

Pre-installed

1

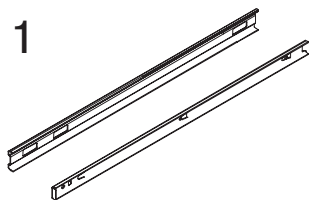

Slide Set

Pre-installed
For installing drawers

4

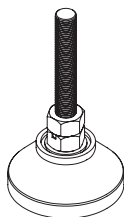

Adjustable Feet

For attaching
to bottom panel

1

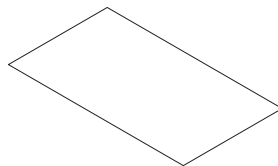

Drawer Liner

For protecting drawers

2

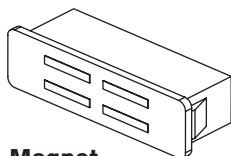

Magnet

Pre-installed
For keeping doors closed

4



Post A

Top and bottom posts
in each stack

2



Post B

Middle post in
each stack

2

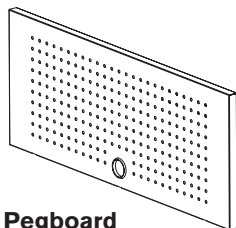

Pegboard

For hanging tools

ASSEMBLY

BASE CABINET ASSEMBLY

Carefully lay the cabinet on its back, with a soft mat underneath for protection.
Screw the four adjustable feet into the cabinet bottom. Turn the cabinet upright.

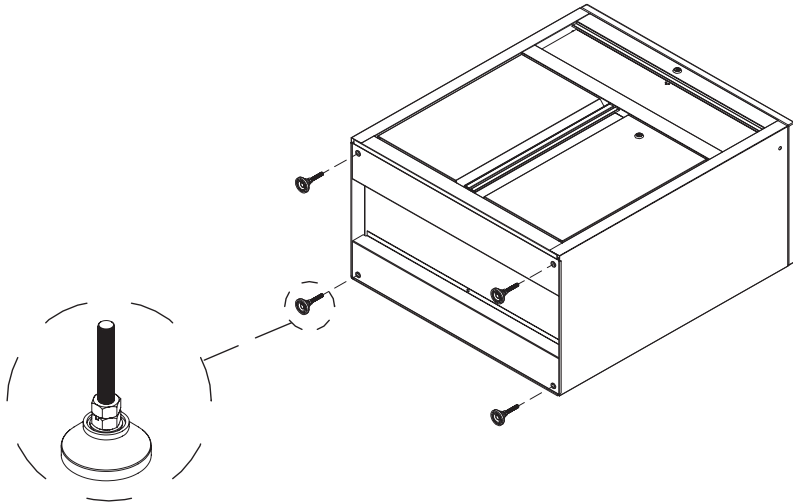

WARNING: DO NOT STACK A 1-DRAWER, 2-DOOR BASE CABINET ON TOP OF ANOTHER CABINET.

WALL CABINET ASSEMBLY

Carefully separate the front and back panels of the wall cabinet, allowing the side panels to unfold completely.

Make sure the unit is upside down.

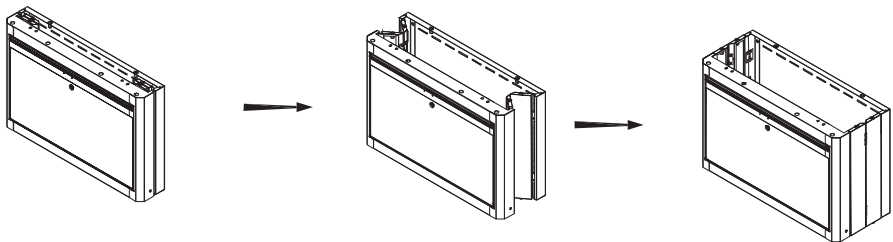

Insert the lip of the bottom panel into the slot in the back of the cabinet, then tilt the bottom panel down. Make sure the holes are aligned.

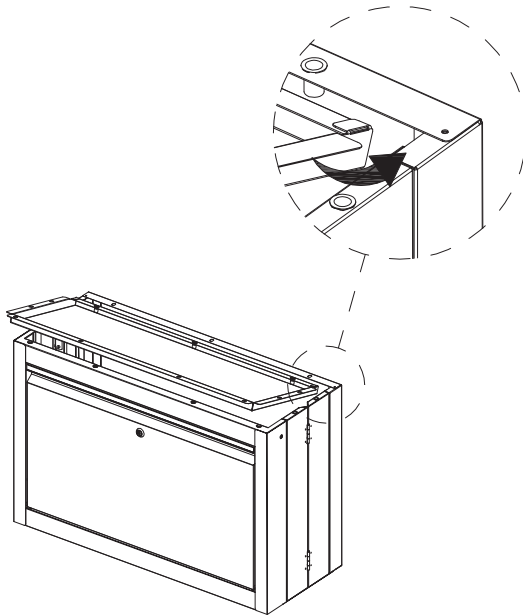

Attach the bottom panel using eleven M6 x 16 mm hex socket head screws.

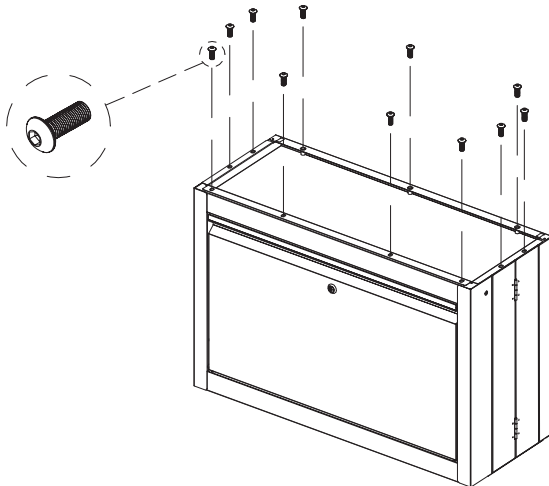

Turn the cabinet back to the upright position. Attach the top panel using eight M6 x 16 mm hex socket head screws.

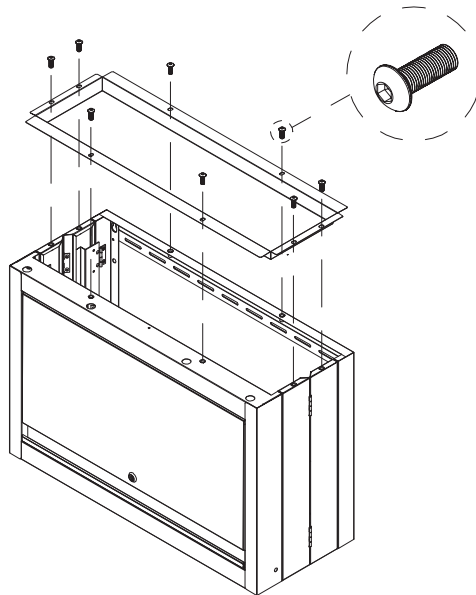

Insert four shelf supports inside the cabinet at the desired height.
Place the shelf on the shelf supports.

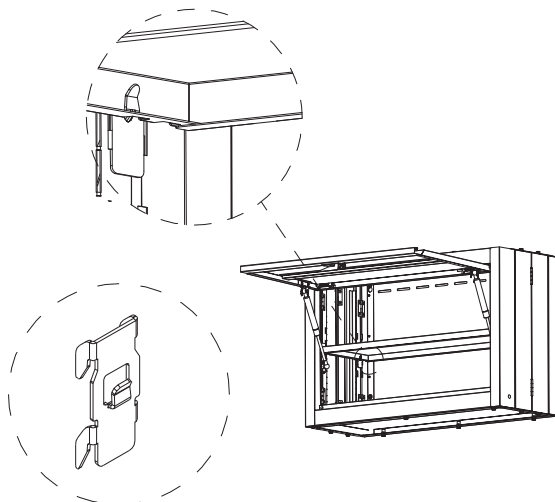

PEGBOARD BACK WALL ASSEMBLY

Attach two A posts to the back of the base cabinet using three M6 x 16 mm hex socket head screws per post.

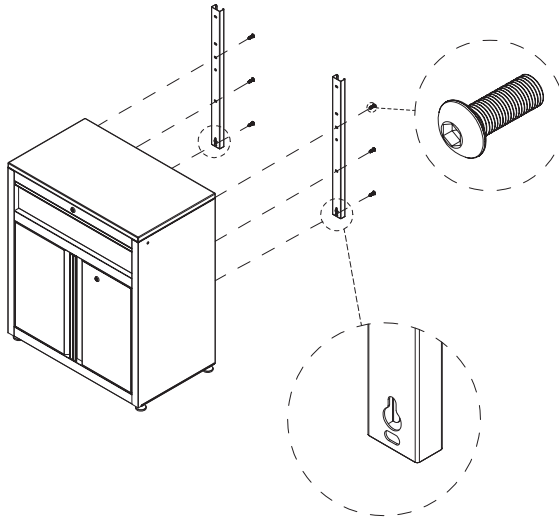

Slide two B posts fully onto the A posts.

Place one pegboard on the front, making sure the grommet hole is on the bottom.

Attach using two M6 x 16 mm hex socket head screws per post.

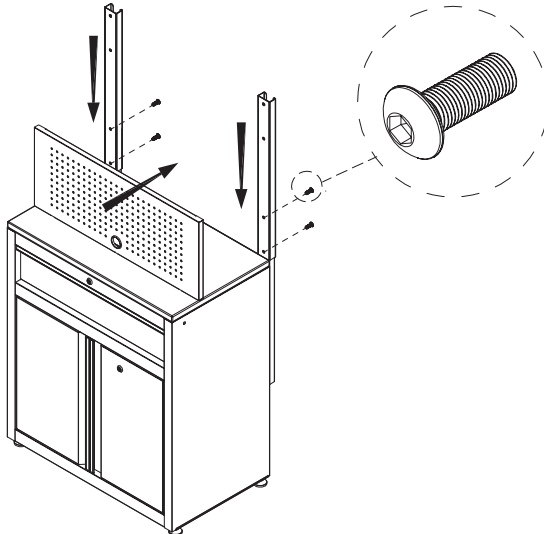

Slide two A posts onto the B posts. Make sure to leave enough room at the top for the wall cabinet.

Place one pegboard on the front, making sure the grommet hole is on the top.

Attach using two M6 x 16 mm hex socket head screws per post.

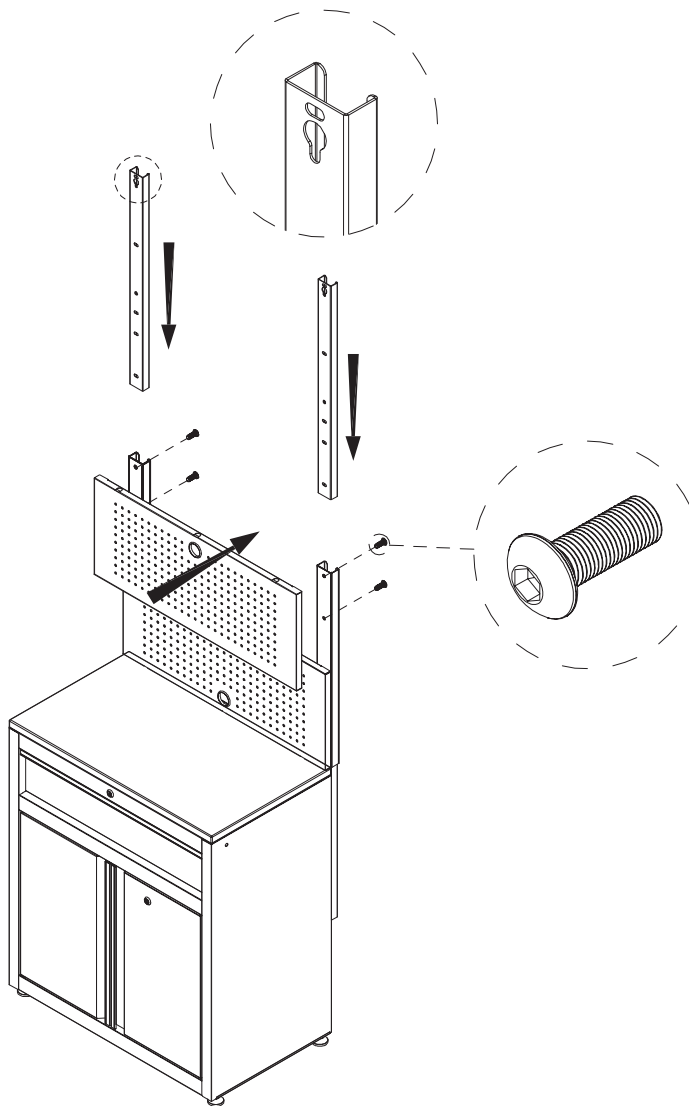

Insert two M6 x 16 mm hex socket head screws into the top holes of the wall cabinet, but do not fully tighten. Hang the wall cabinet on the top of the posts, then fully tighten the screws.

Attach the bottom of the wall cabinet to the posts using two additional M6 x 16 mm hex socket head screws.

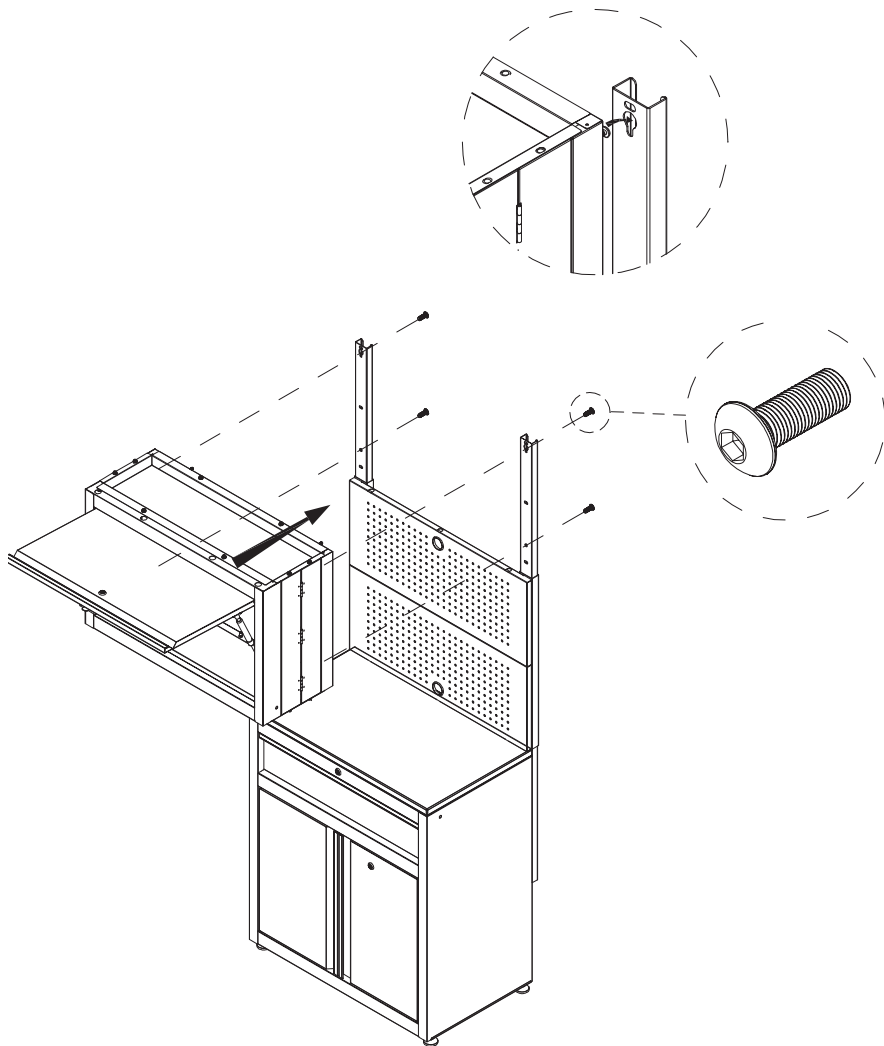

INSTALLATION

If you have purchased other units, assemble them now, then put all units together to build your garage.

For a better appearance, attach the sides of each unit together using M6 x 16 mm hex socket head screws and M6 hex flange nuts at both top and bottom.

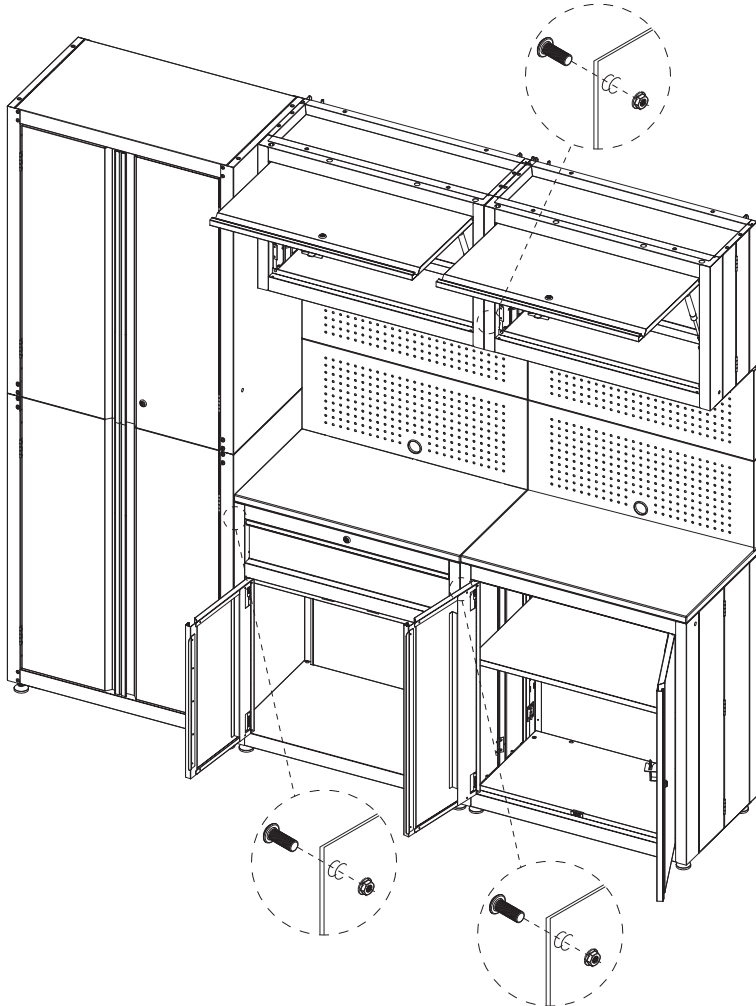

Hide holes on the exterior ends of the units with the supplied end covers, if necessary.

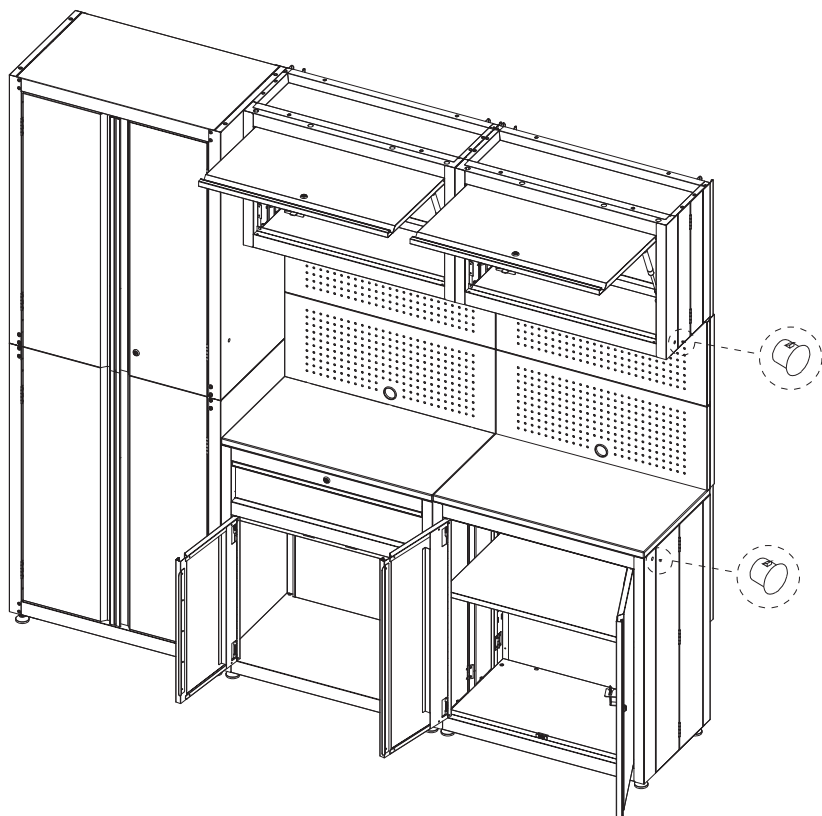

For safety, secure the tops of the each unit to the wall using M6 x 65 mm hex tapping screws and washers. Use three M6 x 65 mm hex tapping screws and washers on wall cabinets and three M6 x 65 mm hex tapping screws and washers on base cabinets.

For best results, mount to studs or other solid surfaces. Do not mount to drywall as it will not support the required weight and poses a danger if mounted incorrectly.

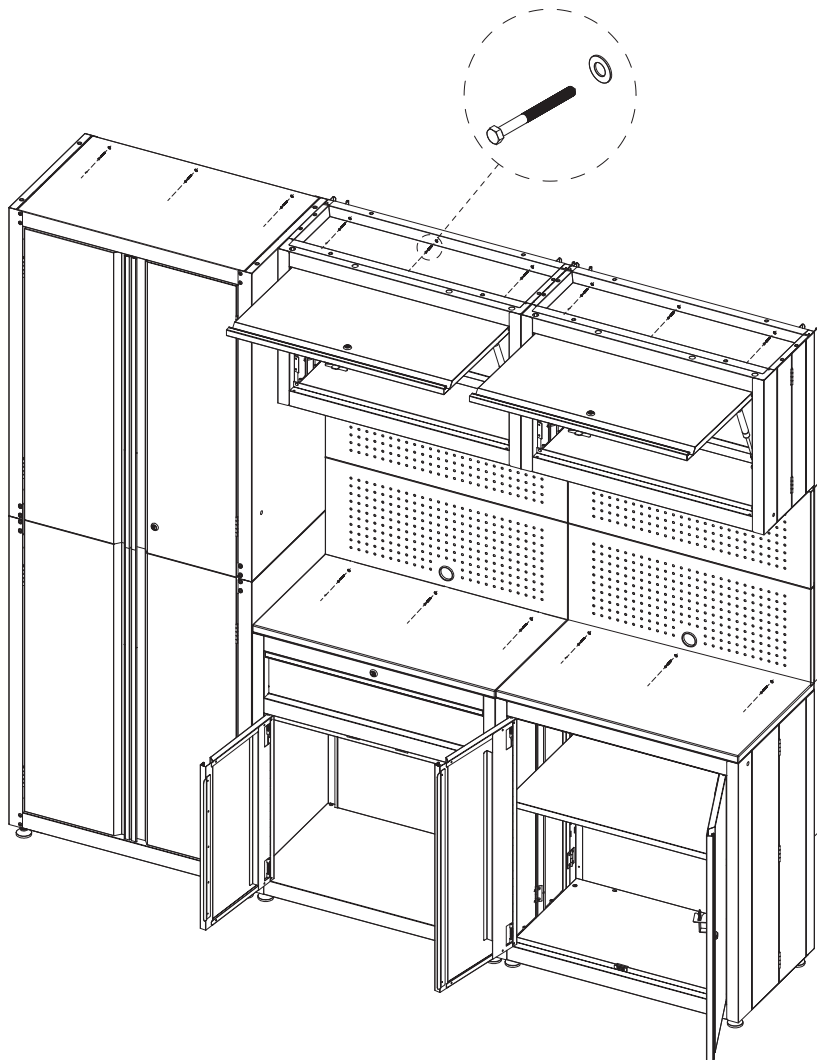

DRAWER REMOVAL

Pull the drawer out so that it's almost fully extended. Push up on the black release lever on one side, while pushing down on the black release lever on the other side. While holding the levers in these positions, pull the drawer outward until it is released from the drawer slide.

ONE SIDE – PUSH UP

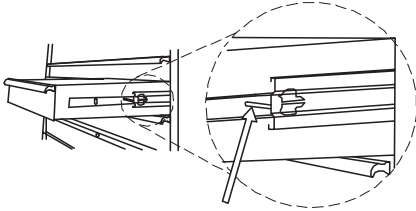

OTHER SIDE – PUSH DOWN

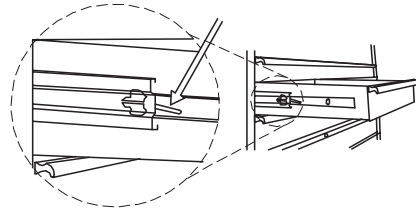

DRAWER REPLACEMENT

Extend the drawer slides from the unit. Insert the brackets on each side of the drawer into the slots in the slides, being careful that they are properly positioned. Once properly inserted, completely close the drawer to set the slides in position.

MAINTENANCE

Periodically clean the drawer and door fronts, trim, and other surfaces with mild detergent and water.

Grease and oil can be removed with most standard cleaning fluids. For safety, use a nonflammable cleaning fluid.

SAFETY

Use two people to move the units into place. Failure to do so can result in back or other injuries.

DO NOT leave children unattended near the garage storage system.

WEAR SAFETY GLASSES when removing or repositioning the slides. The tool could slip, causing personal injury.

DO NOT alter this product in any manner. For example, do not weld external lock bars or attach electrical equipment. This may cause product damage or personal injury.

Close and lock the doors and drawers before moving this product. The doors could come open and make the product unstable and tip, which may cause personal injury or product damage.

Keep the product on level surfaces. The product could become unstable and tip if stored or moved on an uneven surface, which may cause personal injury or product damage.



This product is warranted to be free from defects in materials and workmanship for a period of five (5) years from the date of original purchase.

If this product is defective, email service@montezumastorage.com or call 1-800-459-4409 (Monday–Friday, 8:00 am–4:30 pm, CST). If the product is defective, we will replace the defective part at no cost to you.

Please do not ship your product back to the store or to us unless we send you written instructions for return.

In the event it becomes necessary for your product to be returned, we will notify you how to proceed.

A copy of your original purchase receipt must accompany the returned product.

Montezuma[®]
LIFE ORGANIZED

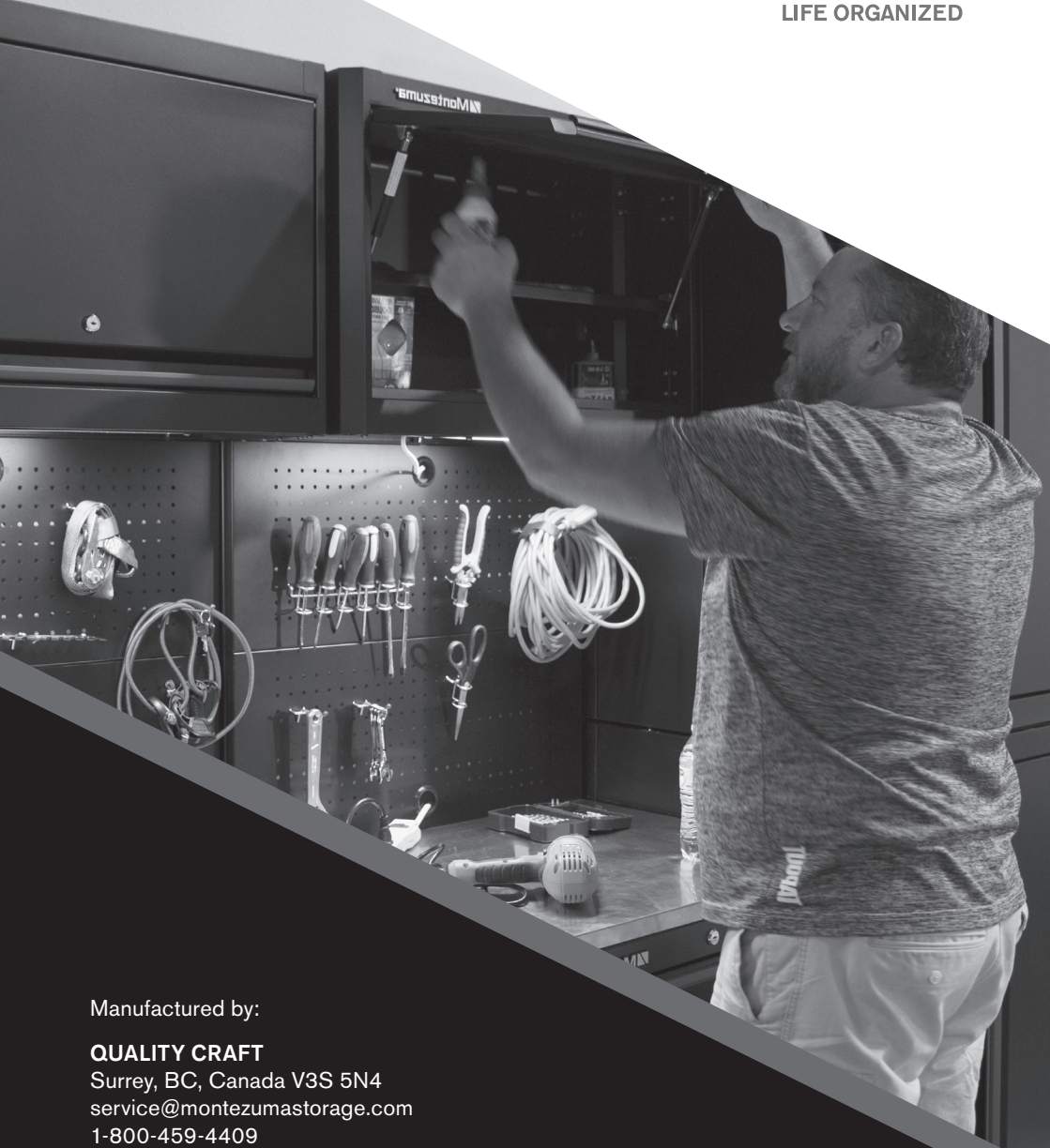

Manufactured by:

QUALITY CRAFT

Surrey, BC, Canada V3S 5N4

service@montezumastorage.com

1-800-459-4409

(Monday to Friday, 8:00 am–4:30 pm, CST)

Made in China

www.montezumastorage.com

MF301DW3-EN/FR-06/19