



OWNER'S MANUAL
56" X 24"
HUTCH

M5624H

www.montezumastorage.com

LIFE ORGANIZED

Montezuma is committed to helping you succeed in both your work and personal life by being organized, prepared and equipped with the right tools, gear and home supplies at your finger tips.

We are here to ensure that your life is organized.

Thank you for your purchase of this Montezuma Hutch.

ATTENTION

TO REDUCE THE RISK OF INJURY, THE USER MUST READ AND UNDERSTAND THIS INSTRUCTION MANUAL BEFORE USING THIS PRODUCT FOR THE FIRST TIME. SAVE THESE INSTRUCTIONS FOR FUTURE REFERENCE.

Fill in the following information and retain this owner's manual for future reference:

MODEL(S):

DATE OF PURCHASE:

PLACE OF PURCHASE:

RECEIPT NO:

SPECIFICATIONS

MAXIMUM SHELF WEIGHT CAPACITY: 100 lb (45 kg)

POWER STRIP

MODEL: LTS-04C/CH-04C

SURGE PROTECTIVE DEVICES

RATING: 120 V AC 15 A 60 Hz 1875 W

USB: TOTAL 2.1 A – Check your device for compatibility

USB O/P: IT EQUIPMENT ONLY

VPR: 500-1000 V (L-N) TYPE 3 SPD

CONFORMS TO UL STD. NO 1363 AND ANSI/UL STD. NO. 1449

CERTIFIED TO CSA STD. C22.2 NO. 308&8

56" x 24" HUTCH

M5624H

OVERALL DIMENSIONS:

56" W x 24-5/8" D x 25" H

(142.2 cm W x 62.5 cm D x 63.5 cm H)

NET WEIGHT: 108 lb (49 kg)

WE RECOMMEND

USING THIS HUTCH

WITH THE MONTEZUMA

56" X 24" TOOL CABINET

BKM562411TC

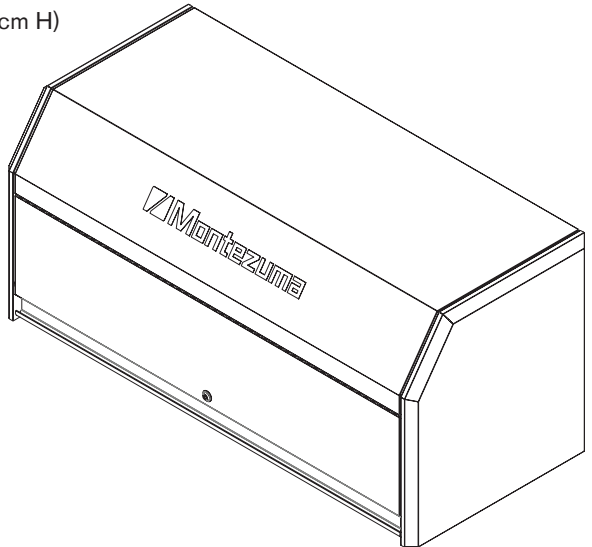

PARTS LIST

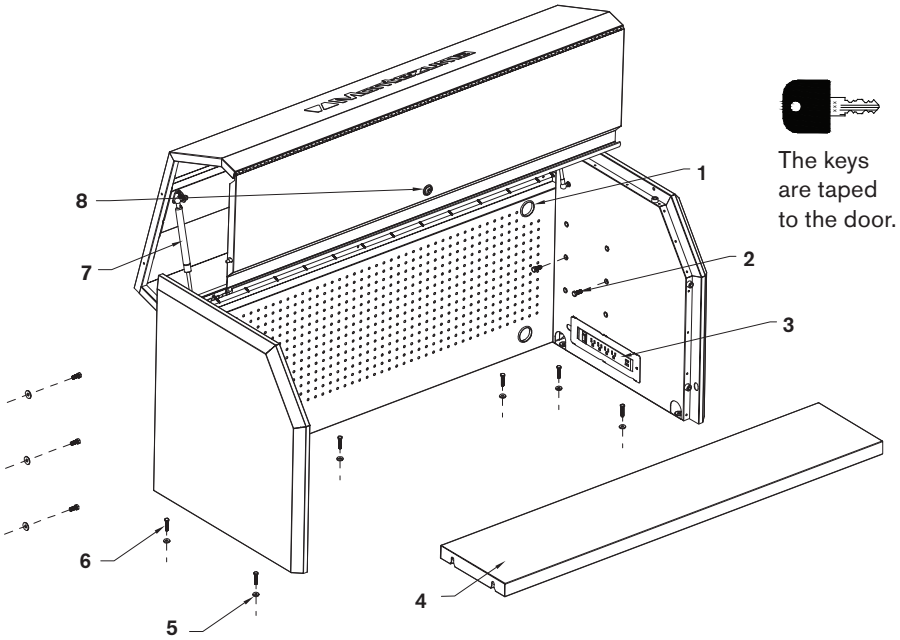

REF	DESCRIPTION	PART NUMBER	QTY
1	Grommet	314027	4
2	M8 x 20 Hex Bolt	321024	16
3	Power Strip	333059	1
4	Shelf	242035	1
5	Washer	324002	16
6	M8 x 40 Hex Bolt	321048	6
7	Gas Strut	303218	2
8	Lock and Key (1201-1204)	304166	2

To order replacement parts, email service@montezumastorage.com or call 1-800-459-4409 (Monday–Friday, 8:00 am–4:30 pm, CST). Have the part number and quantity ready. Replacement keys may be ordered using the code that appears on the face of the lock. Not all parts are covered under warranty. Those parts not covered can be purchased.

4

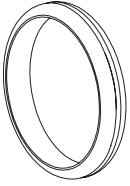

Grommet

For cord access

16

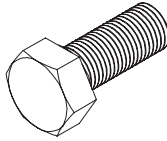

M8 x 20 Hex Bolt

6 for attaching side panels

4 for supporting adjustable shelf

6 for connecting hutch to cabinet without worktop (optional)

1

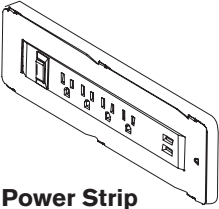

Power Strip

For power management

1

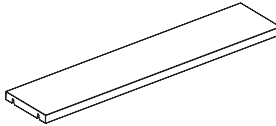

Shelf

For placing at desired height

16

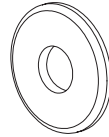

Washer

For use with M8 x 20 Hex Bolt

6

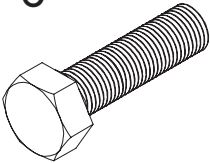

M8 x 40 Hex Bolt

For connecting the hutch and cabinet together

2

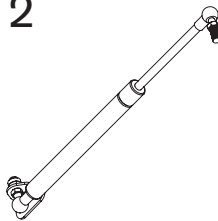

Gas Strut

For lifting the hutch lid

2

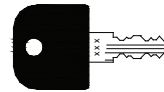

Lock and Key

For securing your valuables

HUTCH ASSEMBLY

Unfold the hutch body as shown.

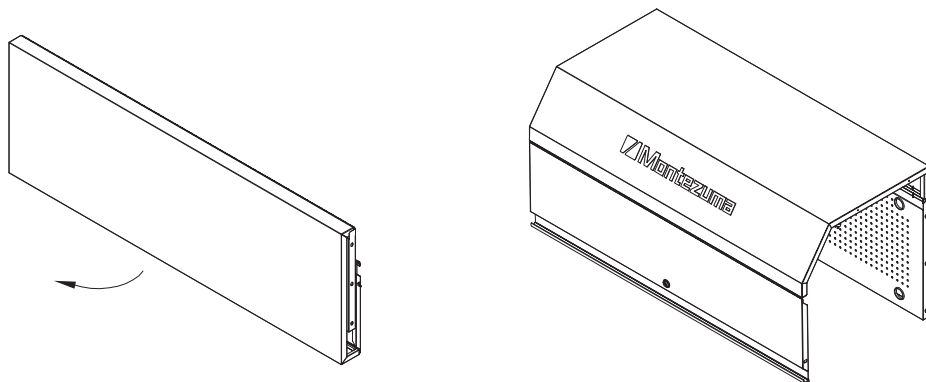

Attach the left and right side panels to the back of the hutch body using three M8 x 20 hex bolts and washers per panel.

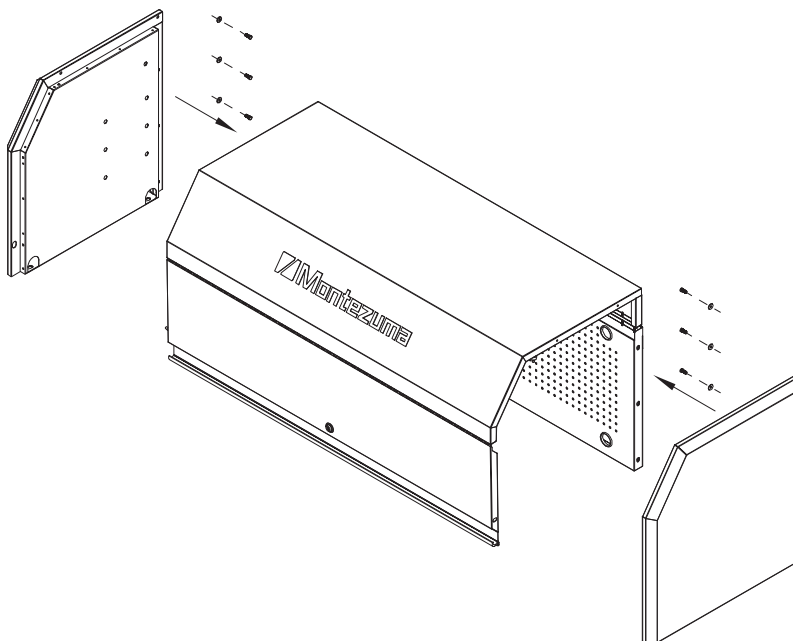

Open the hutch door and install the gas strut.

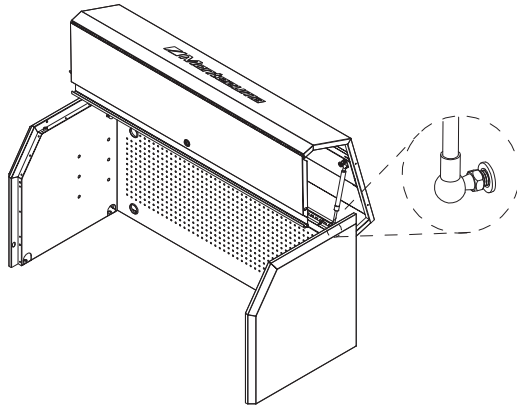

Proceed with connecting the hutch to the cabinet before installing the shelf in the hutch.

HUTCH-CABINET CONNECTION

WARNING: FOR YOUR SAFETY, MOUNT THE HUTCH TO THE CABINET USING ONLY THE HARDWARE PROVIDED.

CONNECTING THE HUTCH TO A CABINET WITH A WORKTOP

Put the hutch onto the worktop. Make sure that both the hutch and the worktop are flush with the front edge of the cabinet and that there are equal gaps on the sides.

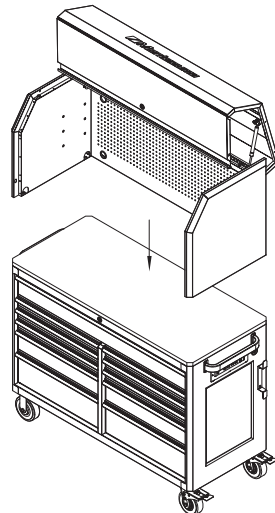

On the worktop, mark the locations of the six slotted holes in the hutch.

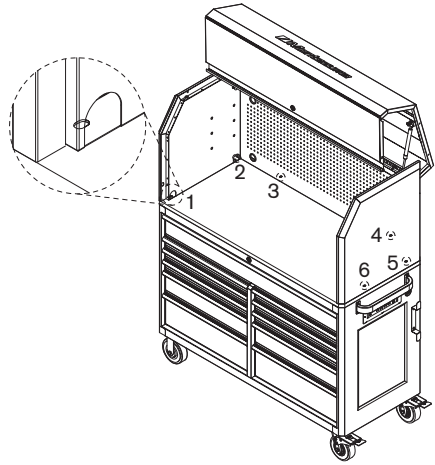

Take the hutch off the cabinet. Remove the worktop by first removing the drawers, then loosening the M6 x 12 Phillips head bolts.

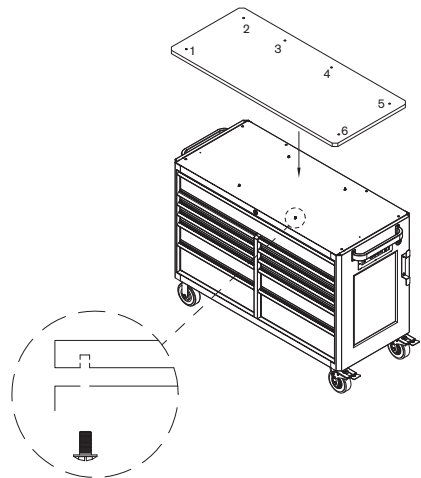

Place the worktop on the floor. Drill six 7/16" (1.1 cm) holes at the locations you marked.

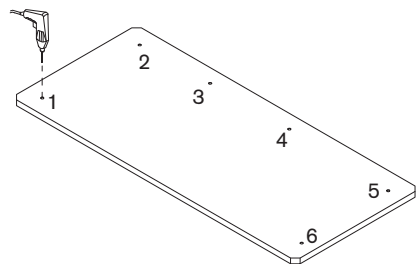

Place the worktop and hutch back onto the cabinet. Make sure that both the hutch and the worktop are flush with the front edge of the cabinet and that there are equal gaps on the sides.

Connect the hutch, worktop and cabinet together using six M8 x 40 hex bolts and washers. An open end wrench is recommended for tightening the hex bolts.

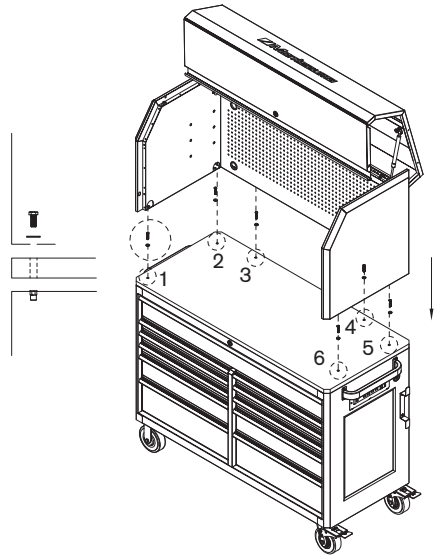

Install the shelf in the hutch using four M8 x 20 hex bolts and washers.

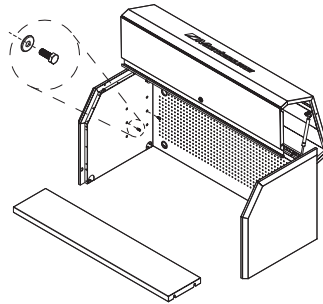

CONNECTING THE HUTCH TO A CABINET WITHOUT A WORKTOP

You may also install the hutch on the cabinet without a worktop.

Remove the worktop by first removing the drawers, then loosening the M6 x 12 Phillips head bolts.

Place the hutch directly on the cabinet top and attach with six M8 x 20 hex bolts. An open end wrench is recommended for tightening the hex bolts.

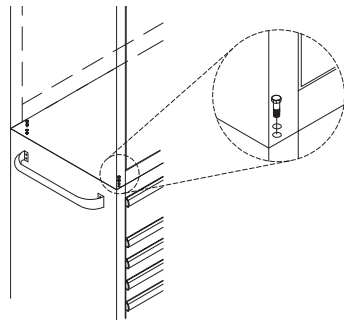

MAINTENANCE

Periodically clean the hutch front, trim, and other surfaces with mild detergent and water.

Grease and oil can be removed with most standard cleaning fluids. For safety, use a nonflammable cleaning fluid.

SAFETY

RISK OF ELECTRIC SHOCK. To reduce the risk of electric shock, use indoors in a dry location only. Do not plug the power strip into another power strip. Not for use for a permanent installation.

Changes or modifications to this unit not expressly approved by the party responsible for compliance could void the user's authority to operate the equipment.

Close and lock the hutch before moving this product.

DO NOT stand or lean on this product.

DO NOT mount this product on a truck bed or any other moving object. This may cause personal injury or product damage, and will void the warranty.

Secure this product properly before moving it with a forklift.

Keep the product on level surfaces. The product could become unstable and tip if stored or moved on an uneven surface, which may cause personal injury or product damage.



This product is warranted to be free from defects in materials and workmanship for a period of five (5) years from the date of original purchase.

If this product is defective, email service@montezumastorage.com or call 1-800-459-4409 (Monday–Friday, 8:00 am–4:30 pm, CST). If the product is defective, we will replace the defective part at no cost to you.

Please do not ship your product back to the store or to us unless we send you written instructions for return.

In the event it becomes necessary for your product to be returned, we will notify you how to proceed.

A copy of your original purchase receipt must accompany the returned product.

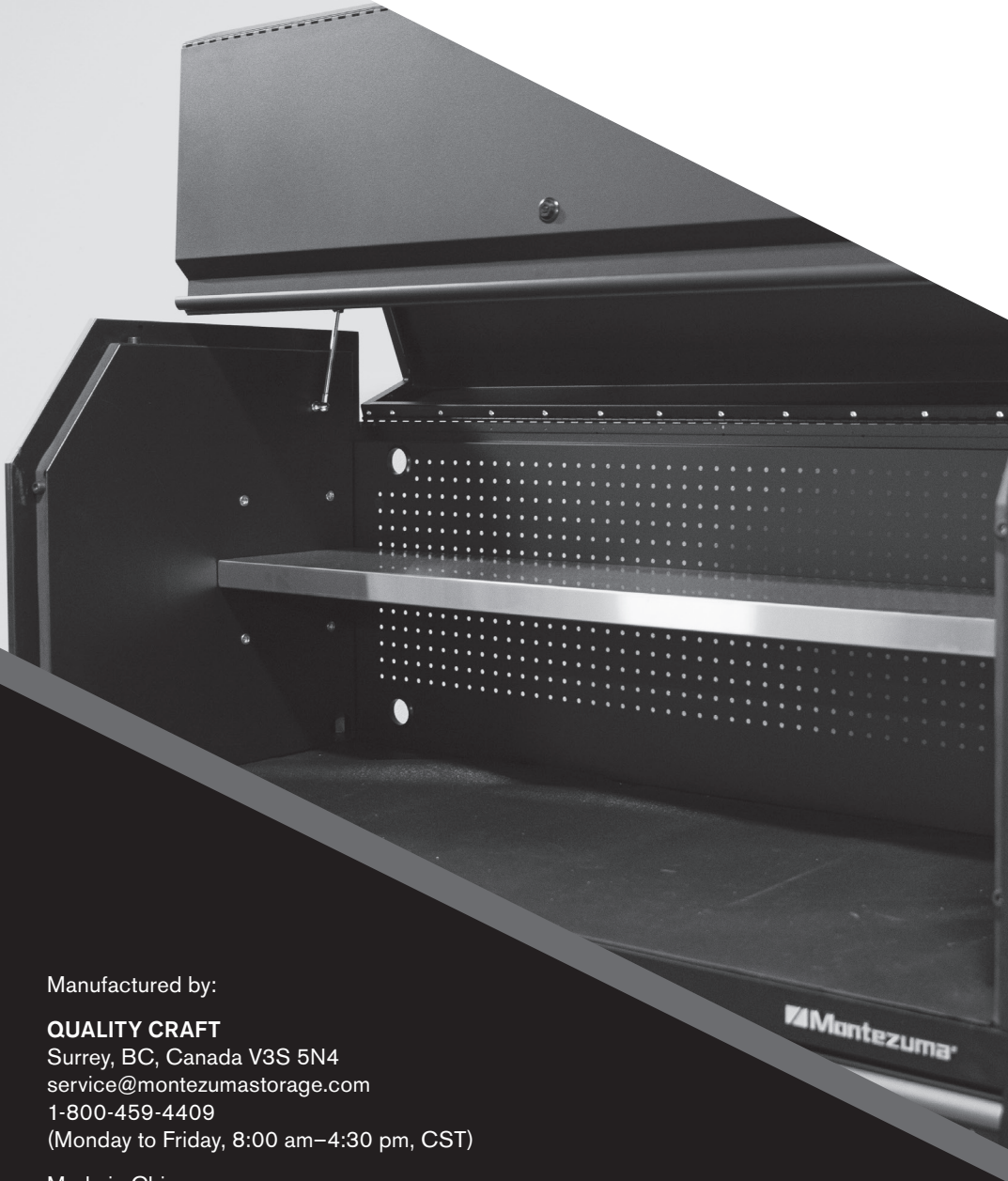

Manufactured by:

QUALITY CRAFT

Surrey, BC, Canada V3S 5N4

service@montezumastorage.com

1-800-459-4409

(Monday to Friday, 8:00 am–4:30 pm, CST)

Made in China

www.montezumastorage.com

M5624H_09/20