



OWNER'S MANUAL  
**16" X 24"**  
**SIDE CABINET**

M1624SC

[www.montezumastorage.com](http://www.montezumastorage.com)

# LIFE ORGANIZED

Montezuma is committed to helping you succeed in both your work and personal life by being organized, prepared and equipped with the right tools, gear and home supplies at your finger tips.

We are here to ensure that your life is organized.

Thank you for your purchase of this Montezuma Side Cabinet.

## ATTENTION

**TO REDUCE THE RISK OF INJURY, THE USER MUST READ AND UNDERSTAND THIS INSTRUCTION MANUAL BEFORE USING THIS PRODUCT FOR THE FIRST TIME. SAVE THESE INSTRUCTIONS FOR FUTURE REFERENCE.**

Fill in the following information and retain this owner's manual for future reference:

MODEL(S):

DATE OF PURCHASE:

PLACE OF PURCHASE:

RECEIPT NO:

# SPECIFICATIONS

MAXIMUM PRODUCT WEIGHT (INCLUDING CONTENTS): 450 lb (204 kg)  
MAXIMUM DRAWER WEIGHT: 150 lb (68 kg)  
MAXIMUM SHELF WEIGHT CAPACITY: 50 lb (23 kg)

## POWER STRIP

MODEL: LTS-04C/CH-04C  
SURGE PROTECTIVE DEVICES  
RATING: 120 V AC 15 A 60 Hz 1875 W  
USB: TOTAL 2.1 A – Check your device for compatibility  
USB O/P: IT EQUIPMENT ONLY  
VPR: 500-1000 V (L-N) TYPE 3 SPD  
CONFORMS TO UL STD. NO 1363 AND ANSI/UL STD. NO. 1449  
CERTIFIED TO CSA STD. C22.2 NO. 308&8

## 16" x 24" 1-DRAWER SIDE CABINET

M1624SC

OVERALL DIMENSIONS:  
15-7/8" W x 24-5/8" D x 33-7/8" H  
(40.3 cm W x 62.5 cm D x 85.9 cm H)  
NET WEIGHT: 93 lb (42 kg)

INSIDE DRAWER DIMENSIONS:

REF	DIMENSIONS	QTY
A	18-1/4" W x 11-3/4" D x 28-7/8" H (46.5 cm W x 29.8 cm D x 73.4 cm H)	1

WE RECOMMEND USING THIS SIDE CABINET WITH ANY MONTEZUMA 24" DEEP TOOL CABINET

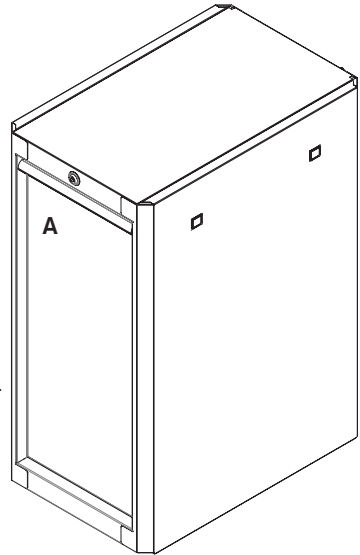

# PARTS LIST

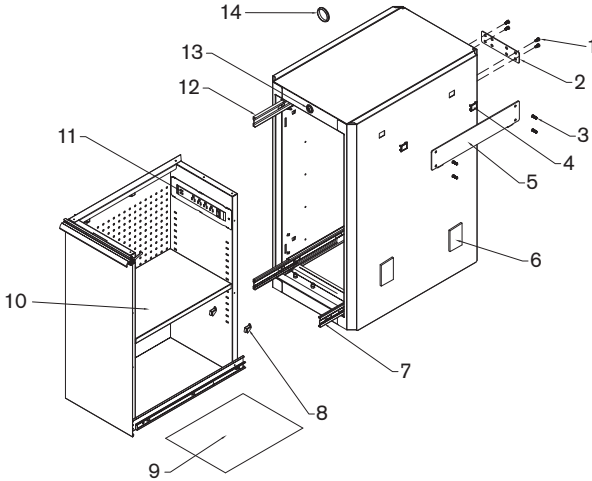

The keys are taped to the inside of the drawer.

REF	DESCRIPTION	PART NUMBER	QTY
1	M6 x 12 Hex Bolt	321051	4
2	Connector	241999	1
3	M6 x 20 Counter Sink Screw	320049	4
4	End Cover	314047	4
5	EVA Liner	600100	2
6	Hanger	241998	1
7	Right Slide	300381	1
8	Shelf Support	203902	4
9	Liner	552156	2
10	Shelf	241997	1
11	Power Strip	333059	1
12	Left Slide	300380	2
13	Lock and Key (1201-1204)	304166	1
14	Grommet	314027	1

To order replacement parts, email [service@montezumastorage.com](mailto:service@montezumastorage.com) or call 1-800-459-4409 (Monday-Friday, 8:00 am-4:30 pm, CST). Have the part number and quantity ready. Replacement keys may be ordered using the code that appears on the face of the lock. Not all parts are covered under warranty. Those parts not covered can be purchased.

4

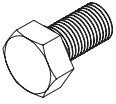

**M6 x 12 mm Hex Bolt**

For attaching the connector

1

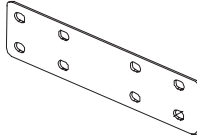

**Connector**

For attaching the side cabinet to a tool cabinet

4



**M6 x 20 Counter Sink Screw**

For installing the hanger

4

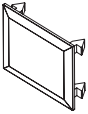

**End Cover**

Pre-installed on side panel – remove when hanging on a tool cabinet

2

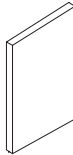

**EVA Liner**

For attaching to the bottom of the side cabinet

1

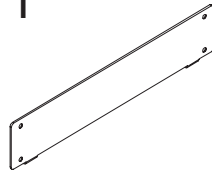

**Hanger**

For hanging the side cabinet on a tool cabinet

1

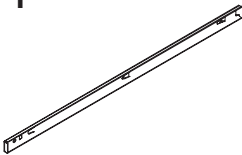

**Right Slide**

Pre-installed  
For installing drawer

4

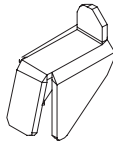

**Shelf Support**

For installing the shelf

2

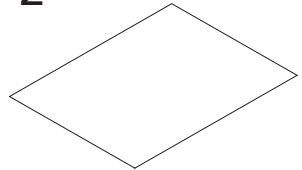

**Liner**

For protecting your drawer and shelf

1

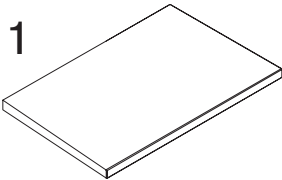

**Shelf**

For placing at desired height

1

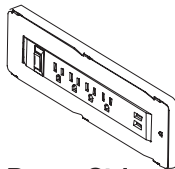

**Power Strip**

For power management

2

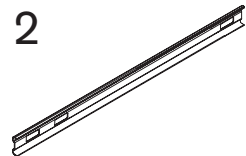

**Left Slide**

Pre-installed  
For installing drawer

1

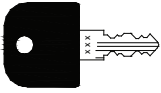

**Lock and Key**

For securing  
your valuables

1

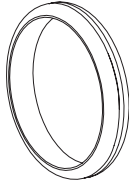

**Grommet**

For cord access

# HANGER INSTALLATION

The hanger can be mounted on either side of a tool cabinet. If necessary, remove the side handles from the tool cabinet.

To install the hanger, position it over the holes in the tool cabinet and attach using four M6 x 20 counter sink screws. Tighten securely.

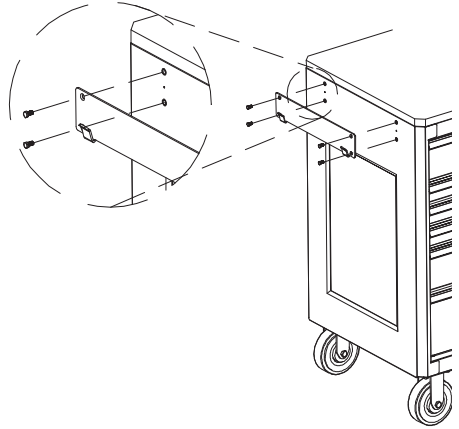

# EVA LINER INSTALLATION

Attach two EVA liners to the side cabinet in the locations indicated.

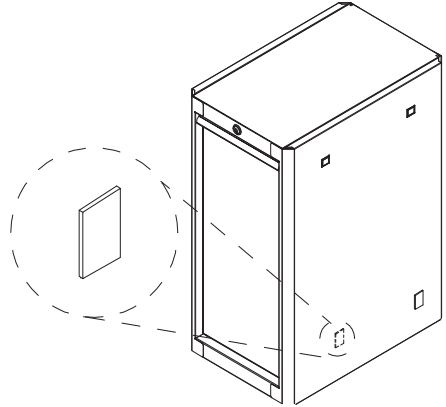

# SIDE CABINET- CABINET CONNECTION

Remove the end covers from the side panel of the side cabinet. Hang the side cabinet on your tool cabinet.

Position the connector on the back of the side cabinet and tool cabinet. Attach to the side cabinet using two M6 x 12 hex bolts and to the tool cabinet with two M6 x 12 hex bolts.

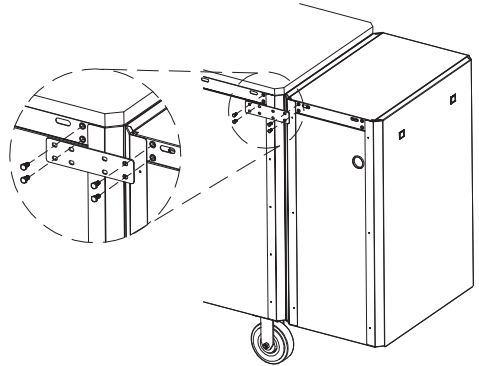

# SHELF INSTALLATION

Insert four shelf supports inside the side cabinet at the desired height.

Place the shelf on the shelf supports.

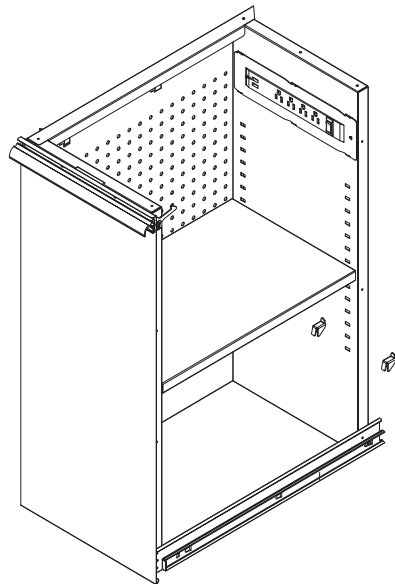



# RAISE AND RELEASE DRAWER FRONTS

These units are equipped with raise and release drawer fronts. To open, lift up on the drawer front while pulling towards you. To close, shut the drawer firmly until the latch engages.

If the drawer does not stay closed, the hook may be bent, or it may be rubbing against the drawer slides. To fix this problem, lightly bend the hook until the drawer will engage in the slide.

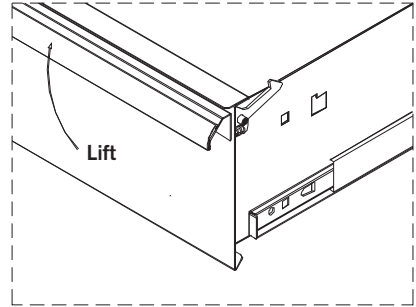

# DRAWER REMOVAL

Pull the drawer out so that it's almost fully extended. Push up on the black release lever on one side, while pushing down on the black release lever on the other side. While holding the levers in these positions, pull the drawer outward until it is released from the drawer slide.

## ONE SIDE – PUSH UP

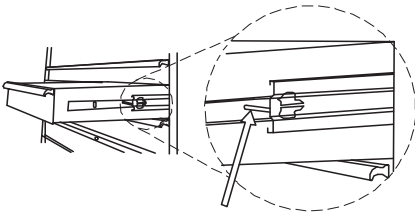

## OTHER SIDE – PUSH DOWN

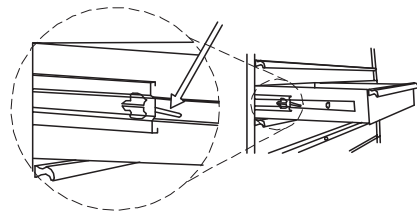

# DRAWER REPLACEMENT

Extend the drawer slides from the unit. Insert the brackets on each side of the drawer into the slots in the slides, being careful that they are properly positioned. Once properly inserted, completely close the drawer to set the slides in position.

# MAINTENANCE

Periodically clean the drawer fronts, trim, and other surfaces with mild detergent and water.

Lubricate the slides (twice a year) with a product like WD40 or other quality lubricant. This is especially important in low temperatures, which can cause the bearing to become stiff.

Grease and oil can be removed with most standard cleaning fluids. For safety, use a nonflammable cleaning fluid.

# SAFETY

**RISK OF ELECTRIC SHOCK.** To reduce the risk of electric shock, use indoors in a dry location only. Do not plug the power strip into another power strip. Not for use for a permanent installation.

Changes or modifications to this unit not expressly approved by the party responsible for compliance could void the user's authority to operate the equipment.

Close and lock the drawer before moving this product. The drawer could come open and make the product unstable and tip, which may cause personal injury or product damage.

DO NOT stand or lean on this product.

**WEAR SAFETY GLASSES** when removing or repositioning the slides. The tool could slip, which may cause personal injury.

DO NOT mount this product on a truck bed or any other moving object. This may cause personal injury or product damage, and will void the warranty.

Secure this product properly before moving it with a forklift.

Keep the product on level surfaces. The product could become unstable and tip if stored or moved on an uneven surface, which may cause personal injury or product damage.



This product is warranted to be free from defects in materials and workmanship for a period of five (5) years from the date of original purchase.

If this product is defective, email [service@montezumastorage.com](mailto:service@montezumastorage.com) or call 1-800-459-4409 (Monday–Friday, 8:00 am–4:30 pm, CST). If the product is defective, we will replace the defective part at no cost to you.

Please do not ship your product back to the store or to us unless we send you written instructions for return.

In the event it becomes necessary for your product to be returned, we will notify you how to proceed.

A copy of your original purchase receipt must accompany the returned product.

**Montezuma**<sup>®</sup>  
LIFE ORGANIZED



Manufactured by:

**QUALITY CRAFT**

Romeoville, IL, USA 60446

[service@montezumastorage.com](mailto:service@montezumastorage.com)

1-800-459-4409

(Monday to Friday, 8:00 am–4:30 pm, CST)

Made in China

[www.montezumastorage.com](http://www.montezumastorage.com)

M1624SC-09/20