



## **Air Fryer Product Guide (MCAF16MB)**

## Introduction

This air fryer is used for cooking food, such as meat, fish, side dishes, and vegetables. This air fryer is not designed for commercial use or operation in a company. This air fryer may only be used for private purposes, as any other use is not as intended. Furthermore, the air fryer may not be used outdoors, or in tropical climates. This air fryer meets all relevant norms and standards in relation to CE conformity. In the event of any modification to the air fryer that was not approved by the manufacturer, compliance with these standards is no longer guaranteed. The manufacturer does not accept any liability for any resulting damage or faults in such cases.

Please observe all regulations and laws in the country of use.



**Before using your air fryer, please read this manual carefully. Incorrect operation can result in serious damage or injury.**

## Need to Contact Us?

<b>WEBSITE:</b>	www.newair.com
<b>SUPPORT EMAIL ADDRESS:</b>	support@newair.com
<b>TELEPHONE NUMBER:</b>	1-855-963-9247

**Manufactured For:**  
**MC Appliance Corp.**  
940 N. Central Ave.,  
Wood Dale, IL 60191 USA

**Magic Chef is a registered trademark of**  
**CNA International, Inc. d/b/a**  
**MC Appliance Corporation.**  
All rights reserved.

**NewAir, LLC**  
6600 Katella Ave, Cypress, CA 90630  
**Comments/Questions:**  
**Support@newair.com**

## Contents

Register Your Product Online..... 4

Important Safeguards ..... 5

Getting to Know Your Magic Chef® Air Fryer..... 9

Air Fryer Settings..... 11

Caring for Your Air Fryer ..... 13

Troubleshooting..... 14

Limited Manufacturer’s Warranty ..... 15

## Product Specifications

---

<b>MODEL:</b>	MCAF16MB
<b>POWER SUPPLY:</b>	120V~ 60Hz
<b>POWER CONSUMPTION:</b>	900W
<b>STEADY TEMPERATURE:</b>	392°F
<b>TIMER FUNCTION:</b>	Up to 30 minutes
<b>BASKET VOLUME:</b>	1.6 Quarts
<b>AUTOMATIC SHUTOFF:</b>	Yes
<b>NON-STICK:</b>	Yes
<b>DISHWASHER-SAFE:</b>	Yes

---

## Register Your Product Online

### Register Your Magic Chef® Product Online Today!

Take advantage of all the benefits product registration has to offer:



#### Service and Support

Diagnose troubleshooting and service issues faster and more accurately



#### Recall Notifications

Stay up-to-date for safety, system updates, and recall notifications



#### Special Promotions

Opt-in for Magic Chef® promotions and offers

Registering your product information online is safe & secure and takes less than 2 minutes to complete:

[newair.com/register](http://newair.com/register)

Alternatively, we recommend you attach a copy of your sales receipt below and record the following information, which can be found on the manufacturer's nameplate on the rear of the unit. You will need this information if it becomes necessary to contact the manufacturer for a service inquiry.

**Date of Purchase:** \_\_\_\_\_

**Serial Number:** \_\_\_\_\_

**Model Number:** \_\_\_\_\_

# **IMPORTANT SAFEGUARDS**

– FOR HOUSEHOLD USE ONLY –

## **1. Read all Instructions**

2. Do not touch hot surfaces. Use handles or knobs.
3. To protect against electric shock do not immerse cord, plugs, or (state specific part or parts in question) in water or other liquid.
4. Close supervision is necessary when any appliance is used by or near children.
5. Unplug from outlet when not in use and before cleaning. Allow to cool before putting on or taking off parts, and before cleaning the appliance.
6. Do not operate any appliance with a damaged cord or plug or after the appliance malfunctions, or has been damaged in any manner. Return appliance to the nearest authorized service facility for examination, repair or adjustment.
8. The use of accessory attachments not recommended by the appliance manufacturer may cause injuries.
9. Do not use outdoors.
10. Do not let cord hang over edge of table or counter, or touch hot surfaces.
11. Do not place the appliance in the presence of explosive and/or flammable fumes.
12. Extreme caution must be used when moving an appliance containing hot oil or other liquids.
13. Do not use appliance for other than intended use.
14. Always attach plug to appliance first, then plug cord into the wall outlet. To disconnect, turn any control to “off”, then remove plug from wall outlet.
15. Be sure to use on a heat resistant and even surface. Keep at least 15 cm away from walls and other flammables.
16. Notice that the tray only can put food or liquid at the 2/3 of capacity.
17. Turn the thermostat knob to the “0”, the appliance stopping working.
18. Before the appliance stops working, the heater surface keeps warm a long time. Do not touch the surface before cooling.
19. Do not operate the appliance without any things, or else the body is easy to change shape.
20. CAUTION: TO REDUCE THE RISK OF ELECTRIC SHOCK, COOK ONLY IN THE PROVIDED REMOVABLE CONTAINER.
21. CAUTION: HOT SURFACE
22. CAUTION: To ensure continued protection against risk of electric shock, connect to properly grounded outlets only.
23. Use extreme caution when removing tray or disposing of hot grease.

24. Do not clean with metal scouting pads. Pieces can break off the pad and touch electrical parts, creating a risk of electric shock.

## **SPECIAL INSTRUCTIONS:**

When the appliance provided with a flexible cord less than 4-1/2 feet(1.4m) in length, the extension cord should be a grounding-type 3-wire cord and meet the following requirements.

a) A short power-supply cord (or detachable power-supply cord) is to be provided to reduce the risk resulting from becoming entangled in or tripping over a longer cord.

b) Longer detachable power-supply cords or extension cords are available and may be used if care is exercised in their use.

Exception: An extension cord or longer detachable cord is not recommended for use with deep-fat fryers and cooker/fryers.

c) If a long detachable power-supply cord or extension cord is used:

1) The marked electrical rating of the cord or extension cord should be at least as great as the electrical rating of the appliance;

2) If the appliance is of the grounded type, the extension cord should be a grounding 3-wire cord;

3) The longer cord should be arranged so that it does not drape over the countertop or table top where it can be pulled on by children or tripped over unintentionally.

# **SAVE THESE INSTRUCTIONS**

This appliance has a polarized plug (one blade is wider than the other). To reduce the risk of electric shock, this plug is intended to fit into a polarized outlet only one way. If the plug does not fit fully into the outlet, reverse the plug. If it still does not fit, contact a qualified electrician. Do not attempt to modify the plug in any way.

**POLARIZED PLUG**



## Important

Please read this manual carefully before you use the appliance and save it for future reference.

## Danger

---

- Never immerse the unit housing in water or rinse under the tap, because it contains electrical components and heating elements that could cause electrical shock.
- Keep all ingredients in the basket, and avoid letting any food come in contact with the heating element.
- Do not cover the air outlet on the back of the unit while it is running.
- Do not pour oil into the frying basket, as it could cause a fire or other malfunctions.
- Do not touch the inside of the appliance while it is operating.

## Warning

---

- This appliance is not intended for use by persons (including children) with reduced physical, sensory or mental capabilities, or lack of experience and knowledge, unless they have been given supervision or instruction concerning use of the appliance by a person responsible for their safety.
- Check if the voltage indicated on the appliance fits the voltage rating of your home outlets.
- Do not use the appliance if there is any damage on the plug, power cord, or any other parts.
- Do not attempt repairs on your own, or take the appliance to an unauthorized service provider.
- Keep the power cord away from hot surfaces.
- Do not plug in the appliance or operate the control panel with wet hands.
- Do not place the appliance against a wall or against other appliances. Leave at least 4 inches of free space on the back, sides and top of the appliance.
- Do not place anything on top of the appliance.
- Do not leave the air fryer unattended while in operation.
- During the cooking process, hot steam is released through the air exhaust. Keep your hands and face at a safe distance to prevent injury.
- Be cautious of any hot steam or air when you remove the basket from the unit.
- Immediately unplug the appliance if you see dark smoke coming out of the exhaust or the frying basket.

## Caution

---

- Ensure the appliance is placed on a horizontal, even, stable surface.
- This appliance is designed for household use only. It may not be suitable to be safely used in environments such as staff kitchens, farms, motels, and other non-residential environments. It is not intended to be used by clients in hotels, motels, or bed and breakfasts.

- If the appliance is used improperly or for professional or semi-professional purposes, or it is not used according to the instructions in the user manual, the warranty will be voided and we reserve the right to refuse any liability for damage caused.
- Always unplug the air fryer while not in use. This unit needs approximately 30 minutes to cool down before it is safe to handle or clean safely.



**CAUTION: FIRE HAZARD. Never use the Air fryer in the vicinity of flammable materials, such as curtains, drapes, etc.**

This unit is equipped with a timer. When the timer reaches zero, you will hear a “ding” and the unit will automatically shut off. To turn off the air fryer manually, press and hold the power button for 3 seconds.



## Getting to Know Your Magic Chef® Air Fryer

### Product Diagram

- |                   |                  |
|-------------------|------------------|
| 1. LED Indicators | 5. Basket handle |
| 2. Timer knob     | 6. Grille insert |
| 3. Housing        | 7. Exhaust vent  |
| 4. Basket         | 8. Power cord    |

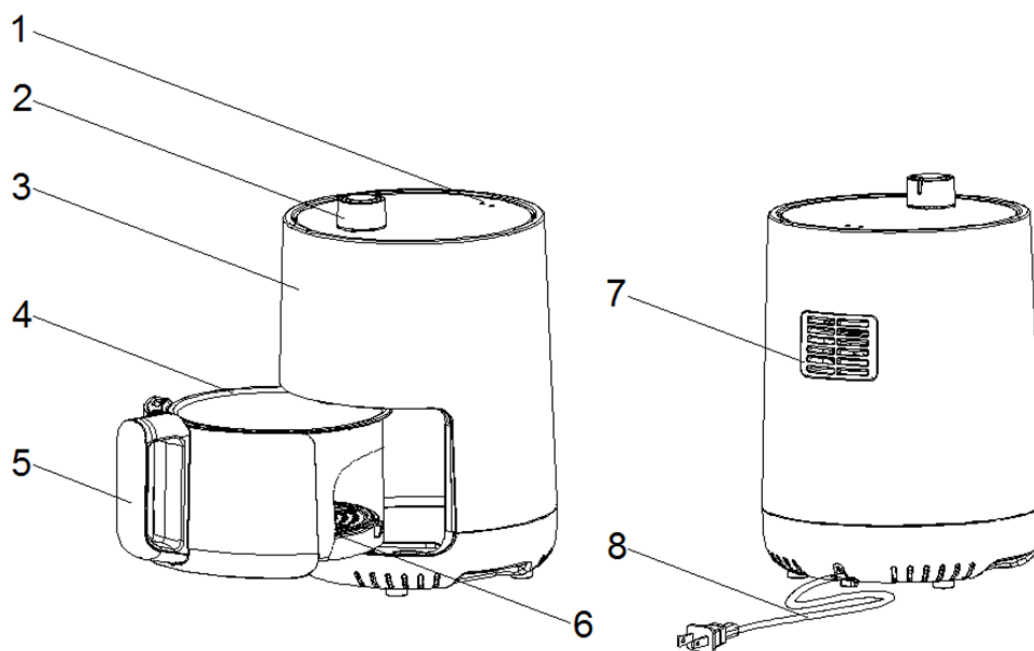

### Before first use

1. Remove all packaging material.
2. Remove any stickers or labels from the appliance.
3. Thoroughly clean the basket and pan with hot water, some mild dish liquid and a non-abrasive sponge.

**Note:** You can also clean these parts in the dishwasher.

4. Wipe the inside and outside of the appliance with a wet cloth.



**This is an oil-free fryer that works using hot air. Do not fill the pan with oil or frying fat.**

## Preparing for use

---

Place the appliance on a stable, horizontal, and even surface.



**Do not place the appliance on a non-heat-resistant surface.**



**Do not fill the pan with oil or any other liquid.**



**Do not put anything on top of the appliance.**

## Quick Start Guide

---

The Magic Chef® Air Fryer can prepare a wide range of foods. See the “settings” section below for ideas!

### Air Frying Instructions

1. Plug in the power cord.
2. Carefully pull the basket out of the unit.
3. Put your ingredients in the basket.
  - **Note:** Do not exceed the MAX fill line with food, as it may negatively affect the cooking process.
4. Slide the basket back into the unit.
  - **Caution:** Do not touch the basket during or immediately after use, as it gets very hot. Only hold it by the handle.
5. Determine the required time for proper cooking of your food (check the “settings” section for recommendations)
  - **Note:** Add 3 minutes to the cooking time if the unit is not warmed up yet. You can also preheat the unit before adding the food to the basket.
  - During the cooking process, the “heating” LED indicator will turn on and off as the heating element works to maintain the steady temperature of 392 degrees.
  - Some ingredients require shaking halfway through the preparation time (see the “settings” section for which foods require this). Pull the basket out of the appliance by the handle and shake it, then slide the basket back into the unit to resume cooking.
  - When the timer runs out, the unit will ding, notifying you that your food is ready.
  - Check if the ingredients are cooked to your liking. If the ingredients are not ready yet, simply slide the basket back into the appliance and set the timer for a few extra minutes.
  - Empty the basket into a bowl or onto a plate.

**Tip:** To remove large or fragile ingredients, lift the ingredients out of the basket using a pair of tongs.

## Air Fryer Settings

This table below will help you to choose timer settings for the specific food you're cooking. Keep in mind that these settings are general recommendations, and results will vary based on the type, size and quantity of your ingredients. **Note that this unit runs only at a steady temperature of 392 degrees.**

### *Helpful Tips*

- Smaller ingredients or quantities usually require only slightly less cooking time than much larger ingredients or quantities. For example, doubling the quantity of food does not require doubling the cooking time.
- Shaking the basket half way through the cooking time (or rotating the food if it's meat or something larger) helps the air fryer cook more evenly.
- Do not prepare extremely greasy ingredients in the air fryer, such as sausages.
- Use pre-made dough to prepare filled snacks quickly and easily. Pre-made dough also requires a shorter preparation time than homemade dough.
- You can also use the air fryer to reheat leftovers. Setting the unit for 5-10 minutes is generally best for this. Just check your food and turn it every few minutes.

	Min-Max Amount (g)	Time (min)	Shake	Extra Information
<b>Potatoes &amp; fries</b>				
Thin frozen fries	200-300	18-20	Shake	
Thick frozen fries	200-300	20-25	Shake	
Potato gratin	300	20-25	Shake	
<b>Meat &amp; Poultry</b>				
Steak	100-300	10-15		
Pork chops	100-300	10-15		
Hamburger	100-300	10-15		
Sausage roll	100-300	13-15		
Drumsticks	100-300	25-30		
Chicken breast	100-300	15-20		
<b>Snacks</b>				
Spring rolls	100-250	8-10	Shake	Use oven-ready
Frozen chicken nuggets	100-300	6-10	Shake	Use oven-ready
Frozen fish fingers	100-250	6-10		Use oven-ready
Frozen bread crumbed cheese snacks	100-250	8-10		Use oven-ready
Stuffed vegetables	100-250	10		
<b>Baking</b>				
Cake	250	20-25		Use baking tray
Quiche	300	20-22		Use baking tray/oven dish
Muffins	250	15-18		Use baking tray
Sweet snacks	250	20		Use baking tray/oven dish

## Caring for Your Air Fryer

### Cleaning



Remove the power cord from the socket before cleaning the unit to prevent risk of electric shock.



Wait until the air fryer has cooled down completely before handling or cleaning the basket, in order to prevent risk of burns.



The air fryer itself must not be immersed in water, as there is a risk of electric shock.

Clean the appliance after every use, especially the frying basket.

**Do not use metal kitchen utensils or abrasive cleaning materials to clean the frying basket, as this may damage the non-stick coating.**

#### Cleaning Instructions:

1. Remove the power cord from the wall socket and let the appliance cool down.
  - **Note:** *Remove the pan to help the air fryer cool down more quickly.*
2. Wipe the outside of the appliance with a wet cloth.
3. Clean the basket with hot water, some dish soap and a non-abrasive sponge.
  - **Tip:** *If food is still stuck to the bottom of the pan, soak the pan in hot water and dish soap for a little while. Then, scrub out the food with a sponge or brush.*

## Troubleshooting

### My Air Fryer does not work

Problem	Possible cause	Solution
The Air Fryer does not work	• The unit is not plugged in.	• Plug the power cord into a compatible outlet.
	• The timer has not been set.	• Turn the timer knob to the required cooking time.

### My food didn't cook properly.

Problem	Possible cause	Solution
The ingredients are not cooked properly.	• There is too much food in the basket.	• Put smaller batches of ingredients in the basket. Smaller batches cook more evenly.
	• The set time is too short.	• Turn the timer knob to the required timer setting.

### The ingredients fried unevenly.

Problem	Possible cause	Solution
The ingredients fried unevenly.	• Ingredients were not shaken/turned half way through the cooking time.	Shake/turn ingredients half way through the cooking time.

### Fried snacks are not crispy when they come out of the air fryer.

Problem	Possible cause	Solution
Fried snacks are not crispy when they come out of the air fryer.	• The food is only crispy when used in a traditional deep fryer.	• Lightly brush some oil on the food.
	• The basket was not placed in the unit correctly.	• Push the basket all the way into the unit.

### White smoke is coming out of the appliance.

Problem	Possible cause	Solution
White smoke is coming out of the appliance.	• Grease from the ingredients is burning off.	• Continue operation as normal (grease burning off should not affect the food or the air fryer negatively)
	• The basket has some leftover food from previous use that's burning.	• Clean the pan thoroughly after each use.

## Limited Manufacturer's Warranty

This appliance is covered by a limited manufacturer's warranty. For one year from the original date of purchase, the manufacturer will repair or replace any parts of this appliance that prove to be defective in materials and workmanship, provided the appliance has been used under normal operating conditions as intended by the manufacturer.

### Warranty Terms

---

During the first year, any components of this appliance found to be defective due to materials or workmanship will be repaired or replaced at the manufacturer's discretion, and at no charge to the original purchaser. The purchaser will be responsible for any removal or transportation costs.

### Exclusions

The warranty will **not** apply if damage is caused by any of the following:

- Power failure
- Damage in transit or when moving the appliance
- Improper power supply, such as low voltage, defective household wiring, or inadequate fuses
- Accident, alteration, misuse, or abuse of the appliance, such as using non-approved accessories, inadequate air circulation in the room or abnormal operating conditions (extreme temperatures)
- Use in commercial or industrial applications
- Fire, water, damage, theft, war, riot, hostility, or acts of God, such as hurricanes, floods, etc.
- Use of force or damage caused by external influences
- Partially or completely dismantled appliances

### Obtaining Service

When making a warranty claim, please have the original bill of purchase with purchase date available. The purchaser will be responsible for any removal or transportation costs. Replacement parts and/or units will be new, remanufactured, or refurbished and are subject to the manufacturer's discretion. Do not use an unauthorized person to replace or fix a damaged main cord.

For technical support and warranty service, please email [support@newair.com](mailto:support@newair.com)