

FRIGIDAIRE

2-IN-1 EVAPORATIVE COOLER AND FAN

EC100WF

Owner's Manual



Intertek

Manual v1.6

READ AND SAVE THESE INSTRUCTIONS.

TABLE OF CONTENTS

Register Your Product Online	3
Safety Information & Warnings	4
Parts List	6
Features.....	7
Product Installation And Usage	8
Cleaning And Maintenance	12
Limited Manufacturer's Warranty	14

SPECIFICATIONS

MODEL NO	EC100WF
RATED VOLTAGE	120V
RATED FREQUENCY	60 Hz
RATED POWER	45W
NOISE	≤55dB
AIRFLOW	250 CFM
COVERAGE	100 square feet
DIMENSIONS	Depth: 13.5 in Width: 10.2 in Height: 28.3 in
MAXIMUM CAPACITY OF THE WATER TANK	5.5L (1.45 gal)
MAXIMUM WIND SPEED	≥6.5m/s

Frigidaire is a registered trademark of Electrolux Home Products, Inc.
All rights reserved.

Manufactured under license by:
NewAir, LLC
6600 Katella Ave, Cypress, CA 90630
Comments/questions:
support@newair.com | 855-963-9247

REGISTER YOUR PRODUCT ONLINE

Register Your Frigidaire Product Online Today!

Take advantage of all the benefits product registration has to offer:



Service and Support

Diagnose troubleshooting and service issues faster and more accurately



Recall Notifications

Stay up to date on safety notices, system updates, and recall notifications



Special Promotions

Opt-in for NewAir promotions and offers

Registering your product information online is safe & secure and takes less than 2 minutes to complete:

newair.com/register

Alternatively, we recommend you attach a copy of your sales receipt below and record the following information, which can be found on the manufacturer's nameplate on the back of the unit. You will need this information if it becomes necessary to contact the manufacturer for a service inquiry.

Date of Purchase: _____

Serial Number: _____

Model Number: _____

SAFETY INFORMATION & WARNINGS



In order to use the product safely and to avoid any danger caused by incorrect operation, please pay close attention to the warnings and instructions in this manual.

- Please read all instructions carefully before using this product.
- Before use, please check whether the operating voltage matches the voltage on the label of the unit.
- Cleaning and maintenance should never be done by children without supervision.
- **WARNING:** Unplug or disconnect the appliance from the power supply before servicing or cleaning.
- The appliance is only for household and indoor use.
- This appliance has one polarized plug blade that is wider than the other. To reduce the risk of electric shock, this plug is intended to fit in a polarized outlet only one way. If the plug does not fit fully into the outlet, reverse the plug. If it still does not fit, contact a qualified electrician. Do not attempt to override this safety feature.
- **WARNING:** TO REDUCE THE RISK OF FIRE OR ELECTRIC SHOCK, DO NOT USE THIS FAN WITH ANY SOLID-STATE SPEED CONTROL DEVICE.
- **WARNING:** Chemical Burn Hazard. Keep batteries away from children.
- This product (the remote control) contains a lithium button/coin cell battery. If a new or used lithium button/coin cell battery is swallowed or enters the body, it can cause severe internal burns and can lead to death in as little as 2 hours. Always completely secure the battery compartment. If the battery compartment does not close securely, stop using the product, remove the batteries, and keep it away from children. If you think batteries might have been swallowed or placed inside any part of the body, seek immediate medical attention.
- Turn off the power and remove the power cord (be sure to unplug the power cord when cleaning the body, or else it may cause electric shock and fire or other personal injury).

- When cleaning, use ordinary detergent and a soft brush. Do not use chemical agents.
- Do not use corrosive detergent or solvent.
- Do not clean the appliance with excessive amounts of liquid cleaners, as it may cause electrical shock.
- After cleaning, please ensure that the Outer Dust Filter, Cooling Pad, and Water Tank are correctly installed before using.
- When the product is not going to be used for a long time, remove the power plug, package the product, and prevent dust from entering the body, or else it may cause mechanical damage long-term.

PARTS LIST

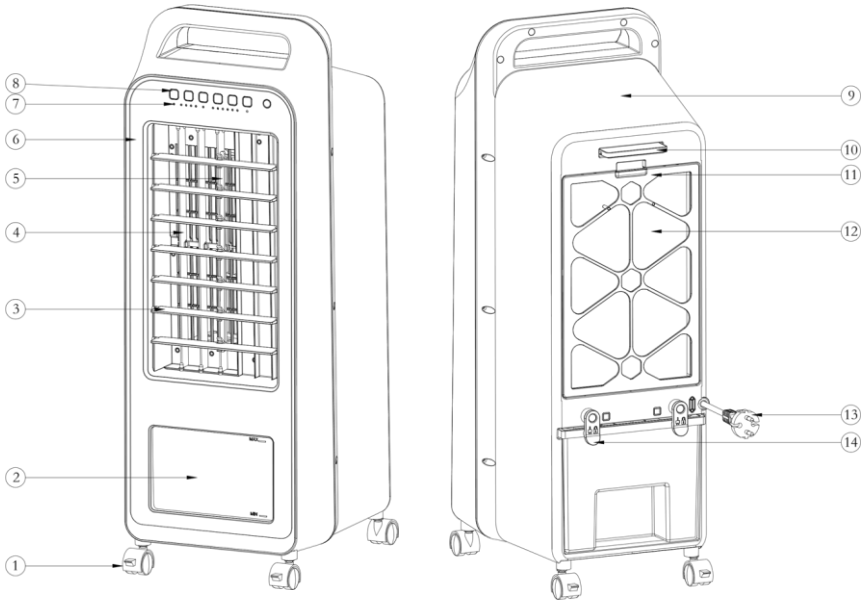

- | | |
|----------------------|--|
| 1. Casters | 8. Control panel |
| 2. Water tank | 9. Rear shell |
| 3. Horizontal blades | 10. Remote control storage |
| 4. Vertical blades | 11. Rear dust filter |
| 5. Outlet grille | 12. Cooling pad |
| 6. Front shell | 13. Power cord |
| 7. LED indicators | 14. Power cord wrapping brackets/water tank lock |

FEATURES

1. Three fan speeds: low, medium, high
2. Three fan modes: normal, nature, and sleep mode
3. Four timer settings: 1h, 2h, 4h, 8h
4. Automatic and manual oscillation (vertical louvers oscillate automatically when the oscillation mode is enabled, and horizontal louvers can be adjusted manually)
5. Remote control with all control panel options
6. Evaporative cooling or fan-only selection
7. Automatic water pump shutdown after extended use
8. Removeable water tank with included ice packs (*Do not break open or modify ice packs in any way—ice packs already contain a freezing gel and do not need to be opened. Place ice packs in the freezer overnight prior to use, for maximum cooling effect. Frozen ice packs should be placed directly into the water tank, on top of the icon labeled “ice box.” Ice packs should only be placed on the “ice box” icon, or they might obstruct or damage the water pump.*)
9. Cooling pad drying cycle
10. Cord wrapping brackets/water tank locks

PRODUCT INSTALLATION AND USAGE

Remove the product from the packaging and review the instructions along with any other included accessories. The unit can be used immediately after being removed and unpacked.

CONTROL PANEL USE



There are 6 function buttons on the main panel (left to right above):

SWING: enables the vertical louvers to oscillate automatically

TIMER: set auto-off timer to 1 hour, 2 hours, 4 hours or 8 hours

EVAPORATIVE COOLING: choose between evaporative cooling and fan-only mode

MODE: choose between normal, nature or sleep modes.

SPEED: choose fan speed; low, medium or high.

POWER: turn the unit on and off.

Note: When first turned on, the unit will run at medium fan speed for a few seconds, then default to low. The LED indicators will dim slightly after 60 seconds without any buttons being pressed.

SWING

When the unit is on, press the swing button to enable the oscillation feature. The vertical louvers will oscillate automatically back and forth 80 degrees in total. In addition, you can manually adjust the horizontal louvers on the front of the unit. To disable the oscillation feature (which can be done while the vertical louvers are at any position along the 80-degree arc), just press the swing button again.

TIMER

While the unit is on, press this button to enable the auto-shutoff feature. Keep pressing the button to cycle through the timer options, 1, 2, 4 or 8 hours. Once the selected time has completed, the unit will shut off.

EVAPORATIVE COOLING

While the unit is on, press this button to enable evaporative cooling. **Please note that in order for evaporative cooling to work, the water tank must be filled in between the min and max fill lines. Remove the tank from the back of the unit and replace it once the water has been filled.** Pressing this button will turn on the water pump, which will run water through the cooling pad on the back of the unit, cooling the air coming into the unit, and thus cooling the air coming out of the front of the unit.

To make the air even colder, drop the included ice packs into the water tank. *(Do not break open or modify ice packs in any way—ice packs already contain a freezing gel and do not need to be opened. Place ice packs in the freezer overnight prior to use, for maximum cooling effect. Frozen ice packs should be placed directly into the water tank, on top of the icon labeled “ice box.” Ice packs should only be placed on the “ice box” icon, or they might obstruct or damage the water pump.)*

The water pump will automatically shut off after 10 hours of operation.

To disable the evaporative cooling feature (and return to fan-only mode), just press the evaporative cooling button again.

MODE

While the unit is on, it will be in normal mode by default. Press this button again to switch to nature mode, a second time to switch to sleep mode, and a third time to switch back to normal mode. In normal mode, the fan operates at a fixed speed set by the user with the fan speed button (see below).

Nature mode: The unit operates normally, except fan speed automatically cycles between the three settings; low, medium and high. This mode is meant to replicate a shifting natural breeze.

Sleep mode: The unit will run for 30 minutes at whatever fan speed was set by the user before changing to sleep mode, then gradually decrease fan speed. If set at high speed, the unit will stay at high speed for 30 minutes, then medium for 30 minutes, then low until the unit is manually shut off.

If set at medium speed, the unit will stay at medium speed for 30 minutes, then low until the unit is manually shut off. Setting the unit at low fan speed then switching to sleep mode will cause no change—the unit will simply stay at low fan speed until a change is made.

SPEED

While the unit is on, press this button to change the fan speed. The unit defaults to low fan speed when you first turn it on, but pressing it once will change the speed to medium, and pressing it a second time will change the speed to high. Pressing it a third time will change the speed back to low. This unit comes equipped with a drying cycle, to help dry out the cooling pad. Press and hold the speed button until the unit beeps and the high fan speed LED lights up and starts flashing. The unit will run on high fan speed for 20 minutes as the cooling pad dries, and then shut off.

POWER

Press this button to turn the unit on and off.

USE OF REMOTE CONTROL

1. First, open the battery cover on the back of the remote control and install a 3V CR2032 battery.
2. When using the remote, point it toward the control panel, which has a receiver on the far right of the panel.
3. When the battery is low, please replace it immediately. Dispose of batteries properly and keep them away from children. Please note that even used batteries could be hazardous.

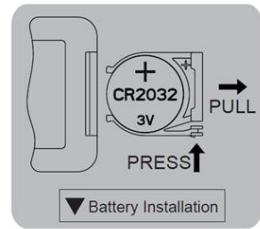
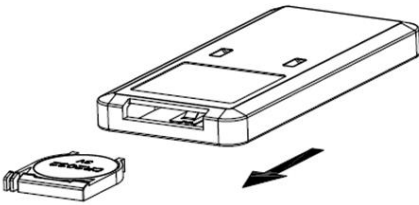

CLEANING AND MAINTENANCE

1. Unplug the unit before cleaning and maintenance.
2. Remove the dust filter and cooling pad for cleaning. Please clean both parts at least once every two months, as dust buildup can affect the efficiency of the unit.
3. To clean the dust filter, use a mild detergent and a soft brush, or vacuum any dust buildup. To clean the cooling pad, soak it in mild detergent for a few minutes, then clean and dry it. You can also use a vacuum to clean the cooling pad as long as it is dry.

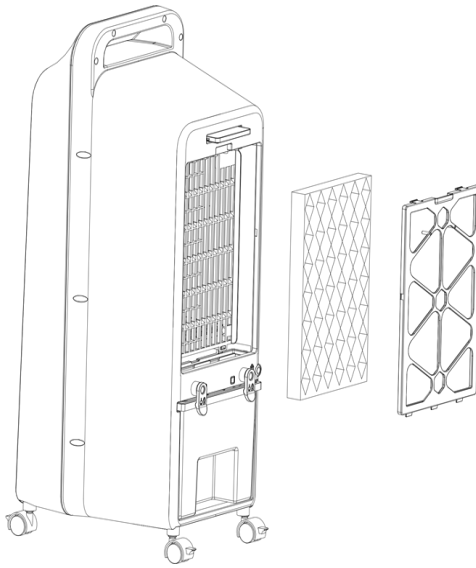

WATER TANK CLEANING

1. Unplug the unit.
2. Remove the water tank, twisting the locking lever away if needed.
3. Dip a towel in mild detergent and wipe the scale in the water tank, then wash with clean water, drain and dry. Alternatively, you can clean it out with dish soap and a brush in your sink.

OUTER SURFACE CLEANING

1. Unplug the unit.
2. Clean the surface of the unit and wipe it off with a damp cloth. Do not rinse the unit directly with water, or use corrosive detergents.

MAINTENANCE

1. When the unit is not going to be used for a long time, unplug the power, pack the unit for storage, and prevent dust buildup by packing the unit into its original box, or covering it with a sheet.
2. Before storing, ensure that the dust filter and cooling pad are completely dry. If either are still wet, run the drying cycle by pressing and holding the speed button until the high fan speed LED starts flashing. The cycle will run for 20 minutes, then the unit will shut off.
3. Store the unit in a dry and well-ventilated area.

LIMITED MANUFACTURER'S WARRANTY

This appliance is covered by a limited manufacturer's warranty. For one year from the original date of purchase, the manufacturer will repair or replace any parts of this appliance that prove to be defective in materials and workmanship, provided the appliance has been used under normal operating conditions as intended by the manufacturer.

Warranty Terms:

During the first year, any components of this appliance found to be defective due to materials or workmanship will be repaired or replaced, at the manufacturer's discretion, at no charge to the original purchaser. The purchaser will be responsible for any removal or transportation costs.

Warranty Exclusions:

The warranty will not apply if the damage is caused by any of the following:

- Power failure
- Damage in transit or when moving the appliance
- Improper power supply such as low voltage, defective household wiring or inadequate fuses
- Accident, alteration, misuse or abuse of the appliance such as using non-approved accessories, inadequate air circulation in the room or abnormal operating conditions (extreme temperatures)
- Use in commercial or industrial applications
- Fire, water damage, theft, war, riot, hostility or acts of God such as hurricanes, floods, etc.
- Use of force or damage caused by external influences
- Adjustments to temperature by removal of stickers and/or screws
- Partially or completely dismantled appliances

Obtaining Service:

When making a warranty claim, please have the original bill of purchase with purchase date available. The purchaser will be responsible for any removal or transportation costs. Replacement parts and/or units will be new, remanufactured or refurbished and are subject to the manufacturer's discretion.

For technical support and warranty service, please email support@newair.com