

**newair**<sup>®</sup>

**SKU:** AC-10100E

---

# Portable Air Conditioner



## **OWNER'S MANUAL**

*Read and save these instructions.*



**Intertek**  
Manual v1.2

---

# READ AND SAVE THESE INSTRUCTIONS.

---

## TABLE OF CONTENTS

Register Your Product Online.....	3
Safety Information & Warnings .....	4
Parts List.....	5
Assembly Instructions .....	6
Operating Instructions .....	9
Cleaning And Maintenance .....	15
Troubleshooting.....	16
Limited Manufacturer's Warranty .....	17

## SPECIFICATIONS

<b>MODEL NO.</b>	AC-10100E
<b>RATED VOLTAGE</b>	115V, 60Hz
<b>COOLING CAPACITY (US DOE)</b>	5950 BTU/hr
<b>RATED CURRENT</b>	874W/ 8.12A
<b>REFRIGERANT</b>	R410A
<b>FAN SPEEDS</b>	2
<b>TEMPERATURE RANGE</b>	64.4 – 89.6 F
<b>NET WEIGHT</b>	55 LBS
<b>PRODUCT DIMENSIONS</b>	12.1" W x 15.3" D x 29.6" H
<b>CEER</b>	6.80
<b>NOISE RATING</b>	57 dB

## REGISTER YOUR PRODUCT ONLINE

### Register Your NewAir Product Online Today!

Take advantage of all the benefits product registration has to offer:



#### **Service and Support**

Diagnose troubleshooting and service issues faster and more accurately



#### **Recall Notifications**

Stay up to date for safety, system updates and recall notifications



#### **Special Promotions**

Opt-in for NewAir promotions and offers

Registering your product information online is safe & secure and takes less than 2 minutes to complete:

[newair.com/register](https://newair.com/register)

Alternatively, we recommend you attach a copy of your sales receipt below and record the following information, located on the manufacturer's nameplate on the rear of the unit. You will need this information if it becomes necessary to contact the manufacturer for service inquiries.

Date of Purchase: \_\_\_\_\_

Serial Number: \_\_\_\_\_

Model Number: \_\_\_\_\_

## SAFETY INFORMATION & WARNINGS

- Read all instructions before using this appliance.
- For indoor use only.
- Leave the unit to stand for 12 hours before connecting to the main supply after transport or when it has been tilted (e.g., during cleaning).
- Only use in the upright position on a flat level surface and with at least a 20 inches (50cm) clearance from any objects.
- Do not use the unit in a potentially explosive environment containing combustible liquids, gases or dusts.
- Do not place objects on the unit or restrict air flow.
- Avoid the unit from getting wet.
- Closely supervise any children and pets when unit is in use.
- This appliance is not intended for use by persons (including children) with reduced physical, sensory or mental capabilities, unless they have been given supervision by a person responsible for their safety.
- Switch off and unplug when not in use.
- Avoid over-twisting, coiling, pulling the power cord.
- If the unit has fallen in water, have it checked before using it again.
- Do not use extension cords.
- If the unit or any parts are damaged contact a qualified technician for repairs.
- Close the doors and windows when unit is in use.
- Keep filters clean.
- The machine is to be used only for its prescribed purpose. The warranty will be void if any damage occurs when used differently than stated in this manual.

**SAVE THESE INSTRUCTIONS**

## PARTS LIST

1. Control panel
2. Air outlet
3. Carrying handle
4. Caster wheels
5. Cord storage
6. Air filter
7. Air inlet
8. Exhaust air outlet
9. Air inlet
10. Rubber plug/ drainage point
11. Exhaust hose
12. Flat Type Adaptor - for insertion over hose & connected with PVC window kit (or into hole in the wall/window)
13. Inward adaptor (connected unit & exhaust hose)
14. PVC Window Kit 1 – for filling the open window space.
15. PVC Window Kit 2 – for filling the open window space
16. PCV Window Kit 3 – for filling the open window space & with hole for connection with exhaust hose
17. Continuous drainage tube
18. Active carbon filter
19. Remote control

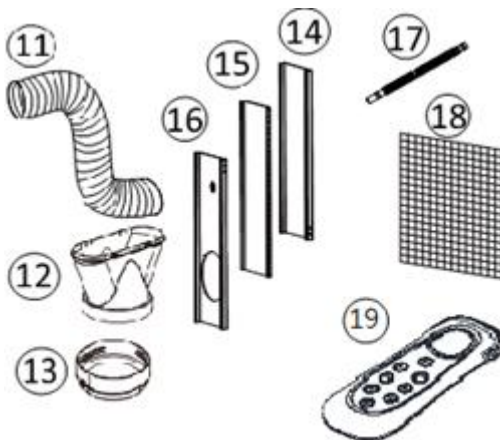
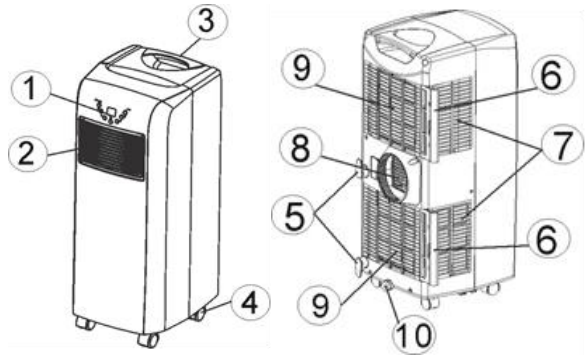

FIG 3

## ASSEMBLY INSTRUCTIONS

Before using your air conditioner, you will need to install the exhaust hose so that the heat from the appliance is released into an open area.

To install the exhaust hose, feed the end of the hose through any available window and secure it into place using the included adapter. Ensure the distance between the unit and the window is at least 20 inches (50cm).

To seal the gap around the adapter, you may utilize the extendable slides (supplied along with the appliance) as below:

### USING THE EXTENDABLE SLIDES

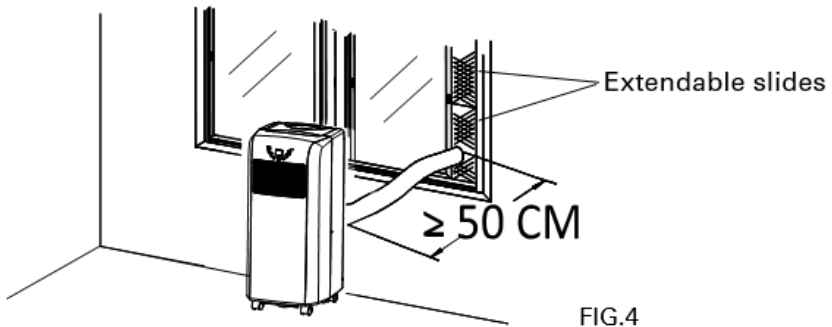

1. Place the extendable slides in the window gap and adjust the length as you need.
2. Feed exhaust hose through the slide and the window so that spacer is held securely. This technique may also be used for sash windows.

**Note:** Take care to maintain protection against intruders

## MOUNTING OF THE EXHAUST PIPE

1. Use only the hose provided and clip exhaust hose to the back of the air conditioner.
2. Avoid kinks and bends in the exhaust hose as this will cause expelled moist air to build up causing the unit to overheat and shut down. Fig 5 & 6 show correct position.
3. The hose may be extended from 12 inches to 60 inches but for maximum efficiency use the shortest length possible.

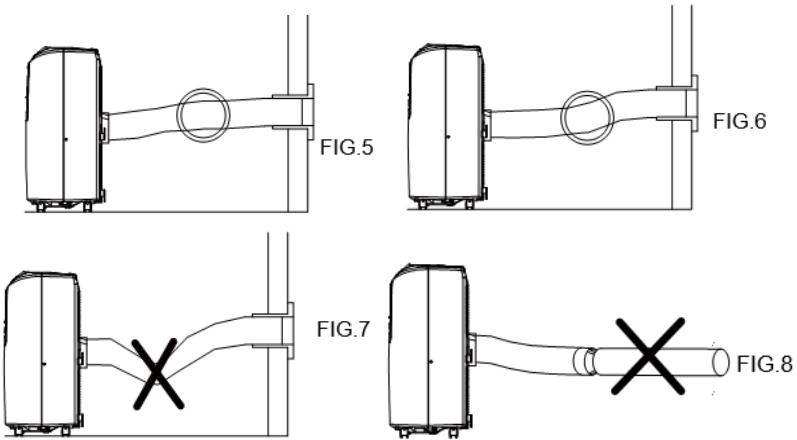

### WARNING!

The length of the exhaust pipe is specially designed according to the specification of this product. Do not replace or extend with different off branded parts as this could cause the unit to malfunction and void the manufacturer's warranty.

## INSTALLATION OF THE CARBON FILTER

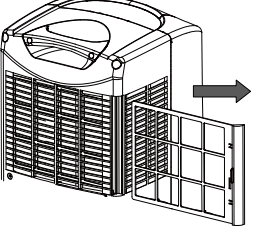
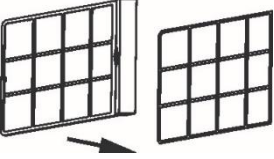
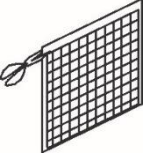
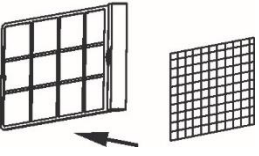
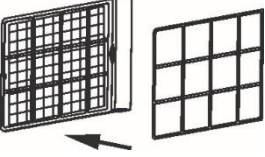
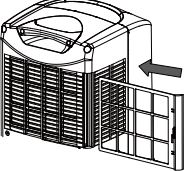
 <p>FIG.9</p>	<p>Remove the filter frame from the unit.</p>
 <p>FIG.10</p>	<p>Remove the filter fixer from the filter frame.</p>
 <p>FIG.11</p>	<p>Remove the active carbon filter from its plastic bag.</p>
 <p>FIG.12</p>	<p>Attach the active carbon filter to the filter frame.</p>
 <p>FIG.13</p>	<p>Attach the filter fixer to the filter frame (the active carbon filter should be held between the filter frame and filter fixer firmly).</p>
 <p>FIG.14</p>	<p>Insert the filter set (filter frame + active carbon filter + filter fixer ) into the back of the unit.</p>



## OPERATING INSTRUCTIONS

## CONTROL PANEL

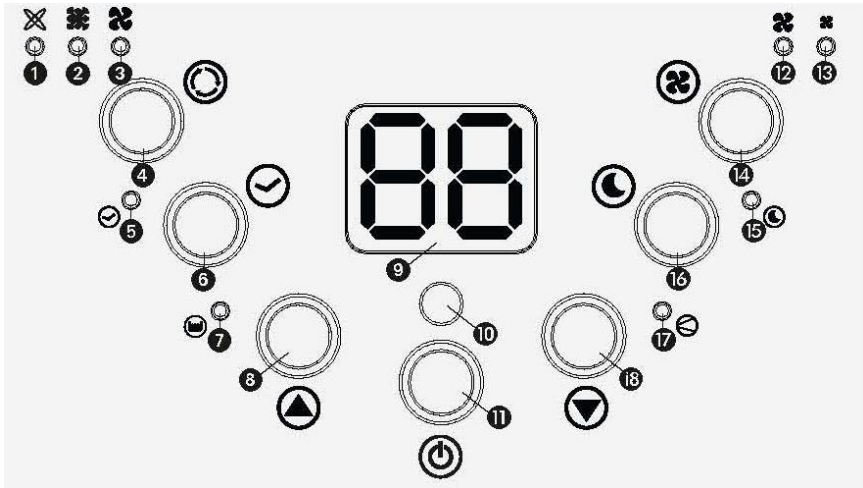

FIG 15

- |                              |                              |
|------------------------------|------------------------------|
| 1. Automatic mode indicator  | 10. Remote control receiver  |
| 2. Cooling mode indicator    | 11. ON/OFF (power) button    |
| 3. Fan mode indicator        | 12. High fan speed indicator |
| 4. Mode selection button     | 13. Low fan speed indicator  |
| 5. Timer operation indicator | 14. Fan speed button         |
| 6. Timer button              | 15. Sleep mode indicator     |
| 7. Full water tank indicator | 16. Sleep button             |
| 8. Temperature up button     | 17. Compressor indicator     |
| 9. Display window            | 18. Temperature down button  |

---

## TURNING ON/OFF

1. Press ON/OFF button, the unit will start automatically.
2. If the ambient temperature is
  - higher than 73°F (22°C), the unit will work in cooling mode.
  - higher than 68°F (20°C) but below or equal to 73°F (22°C), the unit will work in ventilation mode.
3. The display window shows the ambient room temperature from 32°F (0°C) to 122°F (50°C).
4. To turn the unit off, press ON/OFF button again.

---

## SETTING MODE/FUNCTION

Press MODE button to select required working mode: automatic, cooling, or fan. The indicator of your selected mode comes on.

---

## SETTING TEMPERATURE

1. Press 'Temperature up' or 'Temperature down' button to set the desired temperature.
2. The display window will show the temperature you set as you press 'Temperature up' or 'Temperature down' button. Otherwise, it will always show the ambient temperature.
3. The pre-setting temperature of this machine is 75.2°F (24°C) for cooling.

---

## SETTING FAN SPEED

1. Press SPEED button to choose the fan speed you need, high or low. The indicator of high or low ventilation will light on at the same time.
2. If the unit is in AUTO mode, it will choose the fan speed automatically according to the ambient temperature (the related indicators will light on), at this time, the speed switch is invalid.

---

## SETTING TIMER

1. Press TIMER button to set the operating hours you desire (1 to 12 hours, the timer indicator will light on). When the set time has been reached, the machine will turn off automatically. The display window will show the hour(s) you set as you press TIMER button. If the timer button is not pressed, the unit will work continuously.
2. By pressing the timer with the unit off, you can PRE-SET the time for the machine to work. For example, if you set the timer to '2', the unit will turn on automatically after 2 hours.

---

## SLEEP FUNCTION

1. In cooling mode, by pressing the SLEEP button, the set temperature will increase by one degree at the 1st hour, another degree at the second hour, and will stay on that set temperature.
2. In sleep mode, the fan will keep at **low speed**. Re-press the SLEEP button, the setting temperature and fan speed will return to the pre-selected one.
3. The unit will shut down automatically after the SLEEP function has been running for 12 hours.
4. ***Please note, the sleep function is not available while the machine is working in AUTO or FAN mode.***

All the above functions can also be performed with the supplied remote control. This remote control requires 2pcs AAA batteries to operate.



FIG 16

## REGULATING AIR FLOW DIRECTION

Turn the vertical louvers left & right by moving the roller on the air vent. For horizontal louvers, adjust them up & down by hand to control the air flow direction.

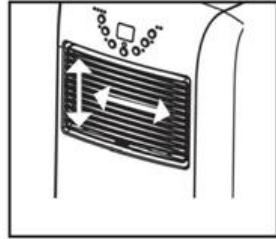

FIG 17

### NOTICE:

1. To protect the compressor, after you turn off the unit, please wait for 3 minutes (at least) before turning it back on if needed.
2. The cooling system will switch off if the ambient temperature is lower than the set one. The fan, however, keeps working on the set level. If the ambient temperature rises above the selected level, the cooling will work again.

## DRAINING THE UNIT

During the process of cooling, some water will be extracted from the air into the unit. If the water reservoir is full, both the compressor and motor will stop, and the unit will buzz (you can press any button to stop the buzz). The Full Water indicator will flash on.

To make the cooling work again, please drain the unit by following these instructions:

1. Turn off the air conditioner and avoid moving it when full.
2. Position a container (e.g., a tray) underneath the drain hole.
3. Remove the drain knob & rubber plug from the drain hole and allow the water to drain out.
4. Replace the rubber plug and tighten the drain knob firmly once all the water has drained out.
5. Switch on the unit and check the Full Water indicator. If all the water has been removed from the reservoir, the indicator will not be flashing.

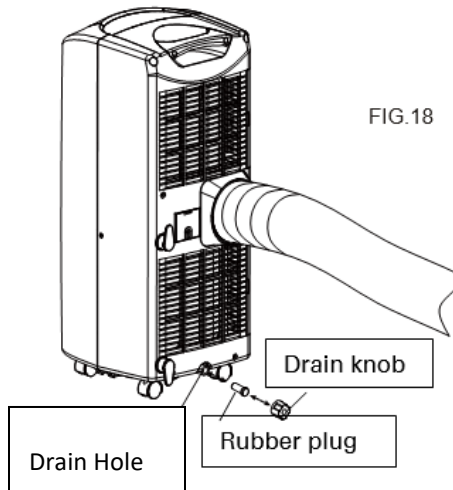

To operate the unit without having to empty the water tank continually, please:

- Remove the drain knob and rubber plug and retain for future use.
- Connect the drain tube provided to the water outlet as shown and place the other end into a water receiver.

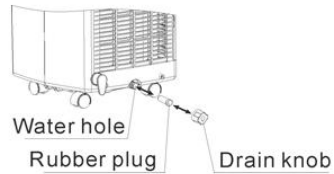

FIG.19

The drain tube may be extended by adding an extension tube and using a suitable connector.

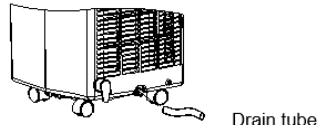

FIG.20

### Please note

1. The drain must be at or below the outlet level.
2. The Full Water indicator will not function when using an extension tube.
3. If you want to extend the water tube, you can connect it with another tube (OD: 18mm)

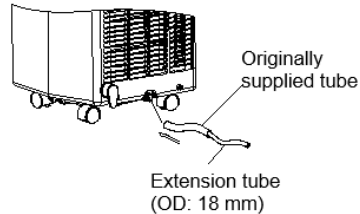

FIG.21

## CLEANING AND MAINTENANCE

Always unplug the air conditioner from the main power line before cleaning. To maximize the efficiency of the air conditioner, clean regularly.

### CLEANING THE HOUSING

- Use a soft, damp cloth to wipe the body clean.
- Never use aggressive chemicals as cleaning solutions.

### CLEANING THE FILTERS

- Use a vacuum cleaner or tap the filter lightly to remove loose dust and dirt from the filters and then rinse thoroughly under running warm water.
- Dry thoroughly before replacing.
- Never operate the unit without the filters.

### END OF SEASON STORAGE

- Drain any water in the unit before completely operating the unit on fan mode for a few hours, to thoroughly dry the inside.
- Clean or change the filter.
- Unplug and store the power cord as shown.
- Place in the original carton or plastic cover for storage.

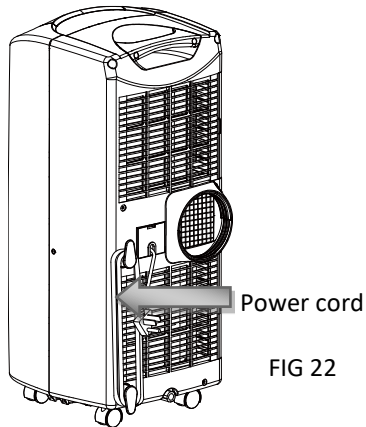

FIG 22

## TROUBLESHOOTING

<b>Problem</b>	<b>Possible Causes and Solution</b>
<b>The air conditioner will not run.</b>	<ul style="list-style-type: none"> <li>• Make sure the air conditioner is plugged in.</li> <li>• Check the Full Water indicator. If it is flashing, please drain the unit.</li> <li>• Make sure the room temperature is not below the set temperature.</li> </ul>
<b>The air conditioner is not cooling enough.</b>	<ul style="list-style-type: none"> <li>• Check that there is no direct sunlight on the unit. Pull down the curtains if need be.</li> <li>• Close all open windows and/or doors.</li> <li>• Make sure there is nothing in the room producing heat.</li> </ul>
<b>The air conditioner is on but will not cool.</b>	<ul style="list-style-type: none"> <li>• Check the filter. Clean if dusty or dirty.</li> <li>• Make sure the air intake or output is not blocked.</li> <li>• Make sure the room temperature is not below the set temperature.</li> </ul>
<b>The air conditioner is too noisy.</b>	<ul style="list-style-type: none"> <li>• Make sure the unit is positioned evenly.</li> <li>• Make sure the unit is level on the floor.</li> </ul>
<b>The compressor will not run.</b>	<ul style="list-style-type: none"> <li>• Wait for the temperature to drop and for the compressor to kick in.</li> </ul>

**NEVER TRY TO REPAIR OR DISMANTLE THE UNIT YOURSELF**



## LIMITED MANUFACTURER'S WARRANTY

This appliance is covered by a limited manufacturer's warranty. For one year from the original date of purchase, the manufacturer will repair or replace any parts of this appliance that prove to be defective in materials and workmanship, provided the appliance has been used under normal operating conditions as intended by the manufacturer.

### **Warranty Terms:**

During the first year, any components of this appliance found to be defective due to materials or workmanship will be repaired or replaced, at the manufacturer's discretion, at no charge to the original purchaser. The purchaser will be responsible for any removal or transportation costs.

### **Warranty Exclusions:**

The warranty will not apply if damage is caused by any of the following:

- Power failure
- Damage in transit or when moving the appliance
- Improper power supply such as low voltage, defective household wiring or inadequate fuses
- Accident, alteration, misuse or abuse of the appliance such as using non-approved accessories, inadequate air circulation in the room or abnormal operating conditions (extreme temperatures)
- Use in commercial or industrial applications
- Fire, water damage, theft, war, riot, hostility or acts of God such as hurricanes, floods, etc.
- Use of force or damage caused by external influences
- Partially or completely dismantled appliances
- Excess wear and tear by the user

### **Obtaining Service:**

When making a warranty claim, please have the original bill of purchase with purchase date available. Once confirmed that your appliance is eligible for warranty service, all repairs will be performed by a NewAir™ authorized repair facility. The purchaser will be responsible for any removal or transportation costs. Replacement parts and/or units will be new, re-manufactured or refurbished and is subject to the manufacturer's discretion. For technical support and warranty service, please email [support@newair.com](mailto:support@newair.com)