

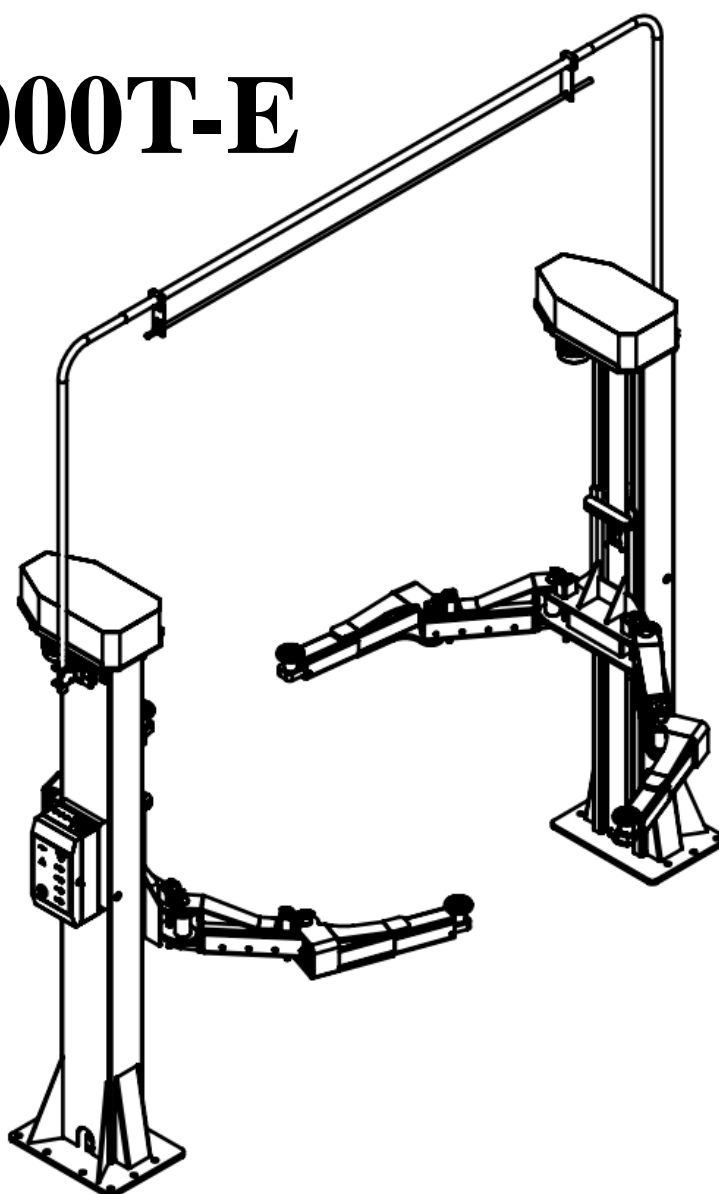

JA6000T-E



USER MANUAL

TWO POST LIFT

Model:

Serial no.:

Manufacture date:

Manufacturer:

Jema Autolifte

Industrihegnet 2, 4030 Tune, Denmark

Tel: +45-48180300

www.jemaautolifte.dk e-mail: info@jemaautolifte.dk

AUTHORIZED SERVICE CENTRE

INSTRUCTION



- Though we have considered about the machine safety during design and manufacture, proper training and frequent operation can be better for the safety. Forbid to operate or repair the lift without reading this user's manual.
- Check the nameplate on motor and currency request on nameplate, only professional electrician is allowed to connect the power.
- Forbid to load vehicle over 6000KG!
- Read the warning content in user's manual carefully!
- We do not take responsibility to the damage due to improper use or operation.

Manufacturer owns the right to make little changes for the manual owing to the improvement of technology.

Contents

CHAPTER 1: Packing	
CHAPTER 2: Description of machine	
CHAPTER 3: Installation	
CHAPTER 4: Adjustment	
CHAPTER 5: Maintenance and care	
CHAPTER 6: Trouble shooting	
Appendix	



Discharge the outside packing and other packing material, to check whether any damage or missing during transportation according to “packing list”. If find damage or missing, should notice the carrier immediately.

PACKING (dimension picture):

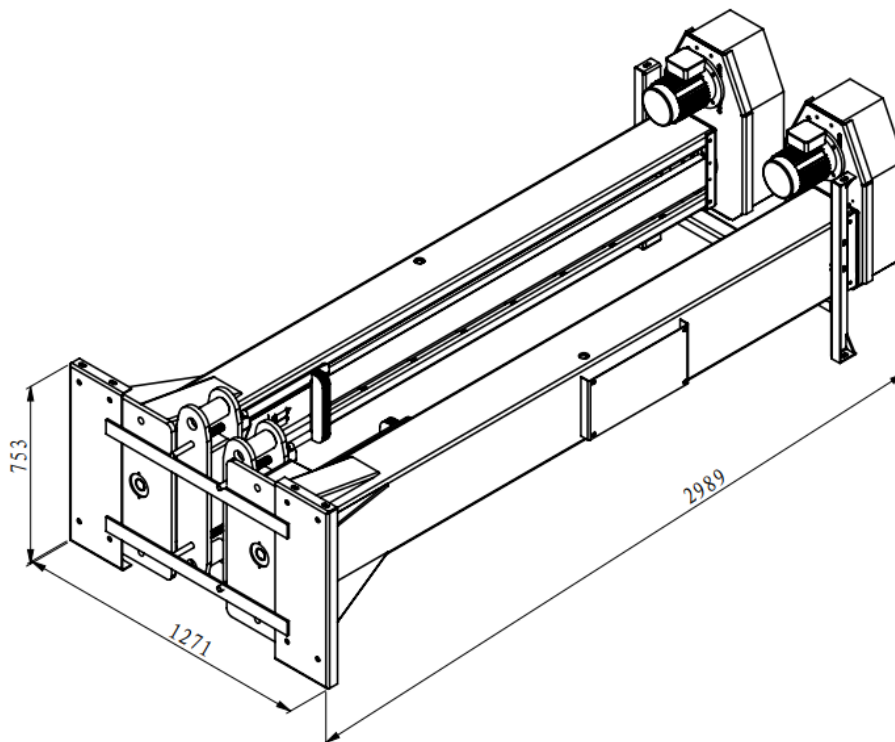

TRANSPORT



**Packing can be lifted or moved by lift trucks, cranes or bridge cranes.
In case of slinging, a second person must always take care of the load, to avoid dangerous oscillations.**

At the arrival of the goods, check for possible damage due to transport operations. Also verify that all items specified in the delivery notes are included. In case of missing parts, it possible defects or damage due to transport operations. Also verify that all items specified in the delivery notes are included. In case of missing parts, possible defects or damage due to transport, the person in charge or the carrier must be immediately informed.

**MACHINES ARE ALL HEAVY GOODS! DON'T MOVE OR LOAD THEM BY MANUAL.
SAFETY IS THE MOST IMPORTANT.**

Furthermore, during loading and unloading operation goods must be handling as shown in the picture

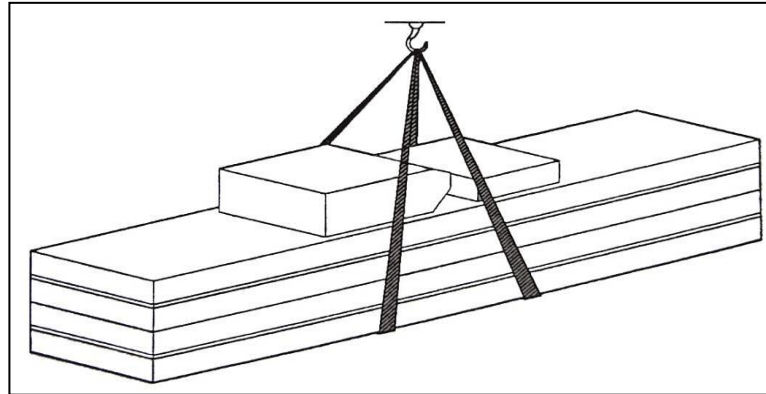

Picture 2 (Goods-lifted)

STORAGE:

Machines must be put in the house, if put them out, should do the anti-water things.
Put them in the temperature between:-25~55°C

CHAPTER 2 DESCRIPTION OF MACHINE

2.1 USAGE

This two post lift can lift various vehicles which weight is less than 6000kg. And it is suitable for vehicle test, repair, maintenance and care.

This lift is designed to lift vehicles, not for other usage.

-Forbid to use for washing and spraying vehicles!

-Forbid to lift vehicle which weight is over 6000KG!

2.2 OVERALL DIMENSIONS (picture 3)

Bending arm type

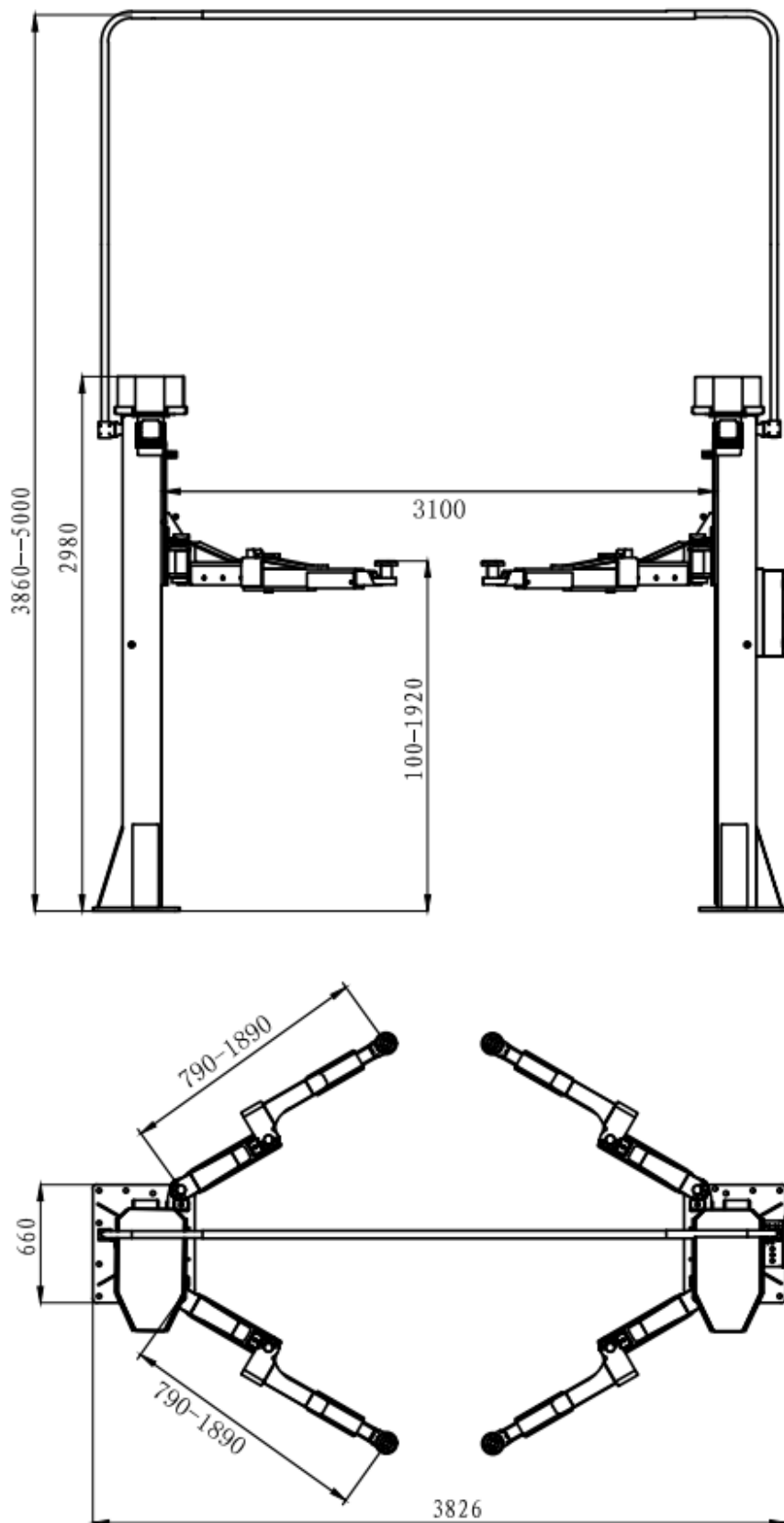

Straight arm type

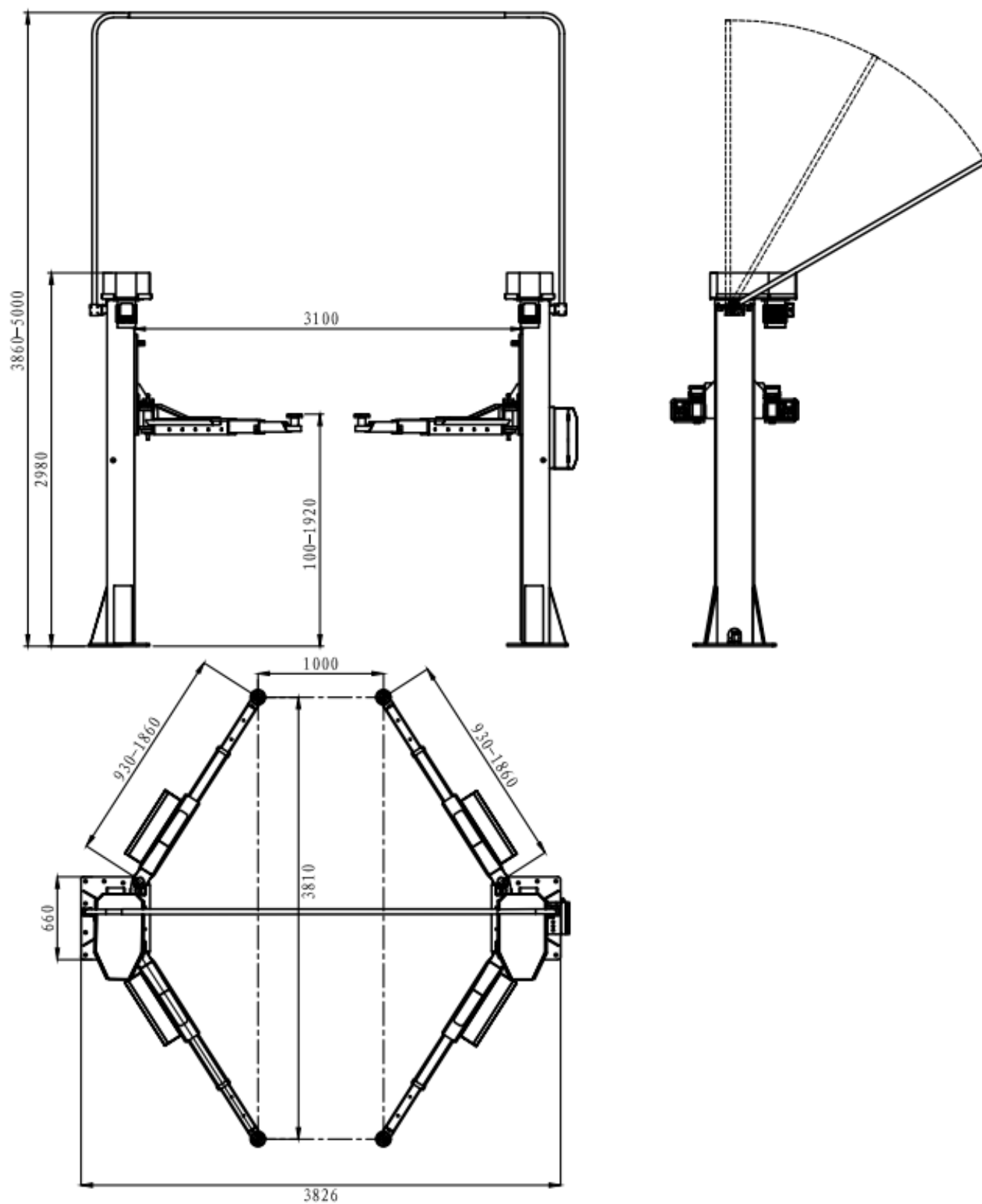

CHAPTER 2 DESCRIPTION OF MACHINE

2.3 TECHNICAL PARAMETER

Max. capacity	6000kg
Lifting time when loaded	57s
Lowering time when loaded	51s
Max. useful height	1920mm
Rubber support adjustment range	100-145
Distance between columns	3100mm
Max. height of lift	5000mm
Max. width of lift	3826mm
Electric motor	230/400V/50HZ
Motor power	2×4.0KW
Controls circuit voltage	24V
Total weight of lift (Max)	1500kg
Average weighed sound level	69dB
Average sound level at the operator's workstation LPA	71dB
Installation place	indoor

Dimensions shown in picture 3 and in the "TECHNICAL SPECIFICATIONS" table are indicative and refer to the lift under no load conditions. Actual dimensions may differ slightly from those reported in this manual.

2.4 LIFT DESCRIPTION

DESCRIPTION OF THE LIFT

- 1) Auxiliary column
- 2) Main Column
- 3) Carriage
- 4) Level 1 rocker arm
- 5) Level 2 rocker arm
- 6) Telescopic arm
- 7) Rubberized pad
- 8) pulley guard cover
- 9) Fixed support
- 10) Motor
- 11) Control box
- 12) Support rod
- 13) Thread of pipe
- 14) Anti-collision rod

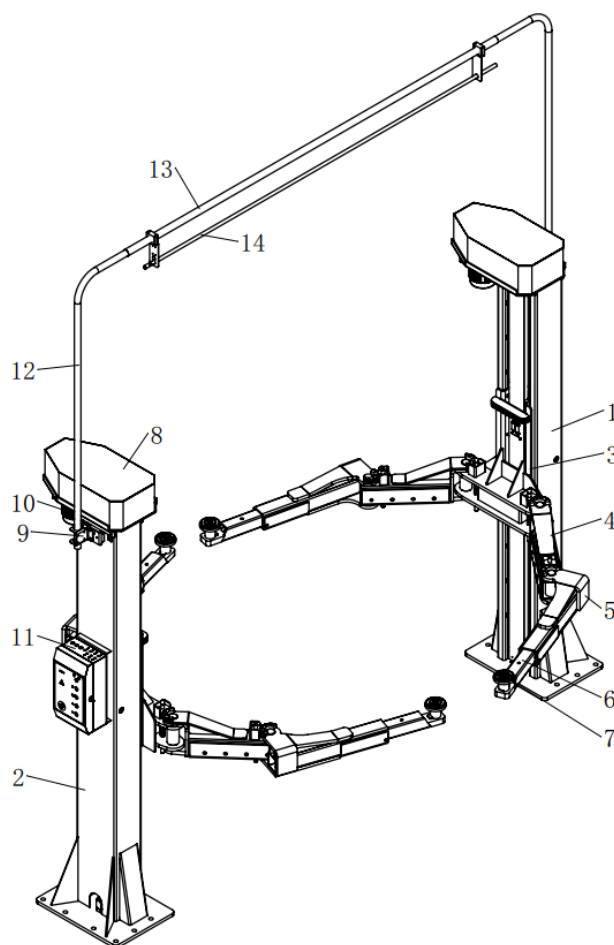

CHAPTER 3 INSTALLATION

3.1 INSTALLATION



WARNING: All the following installation, adjustment and testing operations should be carried out only by qualified and responsible staff operating according to the applicable electric, mechanic and building safety standards.

DANGER: Lift installation, adjustment and testing include potentially dangerous operations; you must thus carefully read all the instructions described hereinafter. In case of doubts, directly contact the Manufacturer, who disclaims any liability due to the failure to comply with the safety and accident-prevention rules specified in this manual.

3.2 FOUNDATIONS

Lift shall be laid onto a reinforced concrete layer class "RcK 30" (3000N/cm²) with a min. thickness of 20 centimeters and spanning at least 1.5 m away from anchoring points. The concrete platform shall be smooth and perfectly levelled in all directions, and cast on a compact ground. The overall dimensions of the full system are given in picture5



It's very important for the floor layout (picture 5). If it's not correct, there may be some problems during installation and operation. The total level error is less than 4mm, which can decrease the problems during final installation.

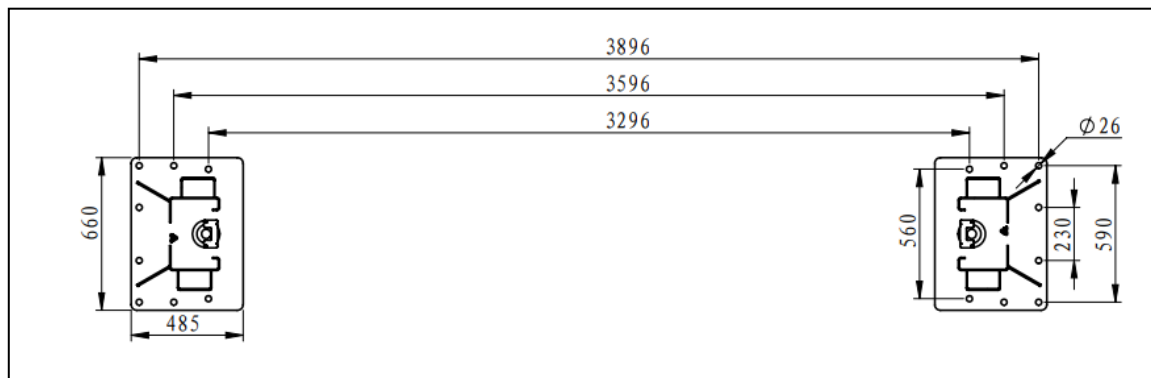

Picture 5

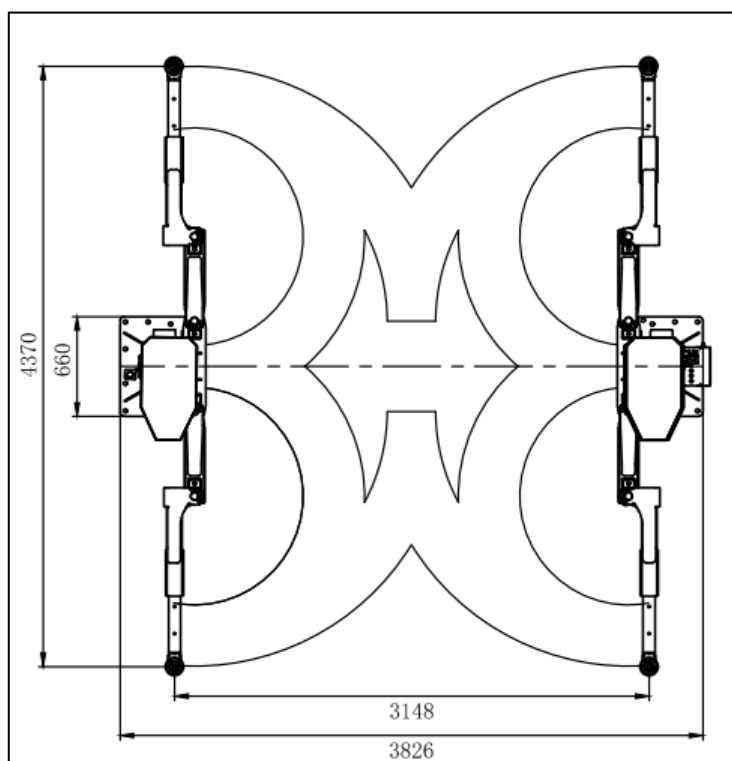

Picture 6

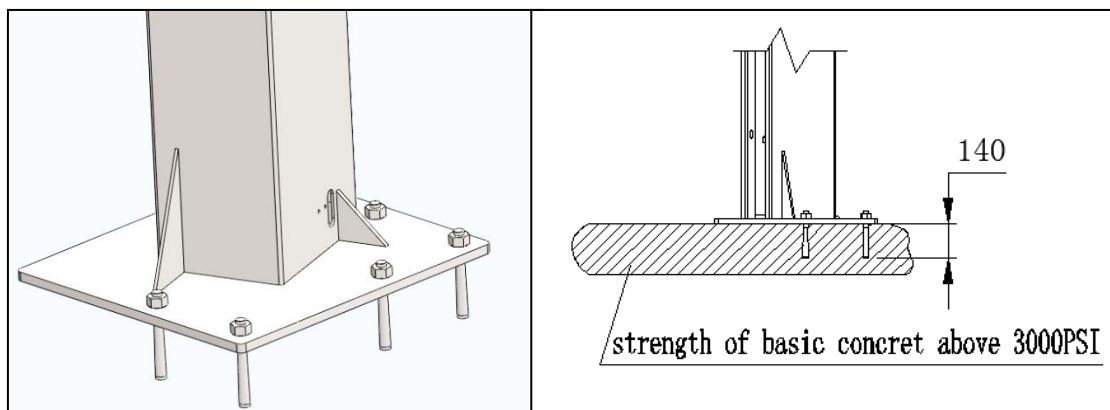

Picture 7

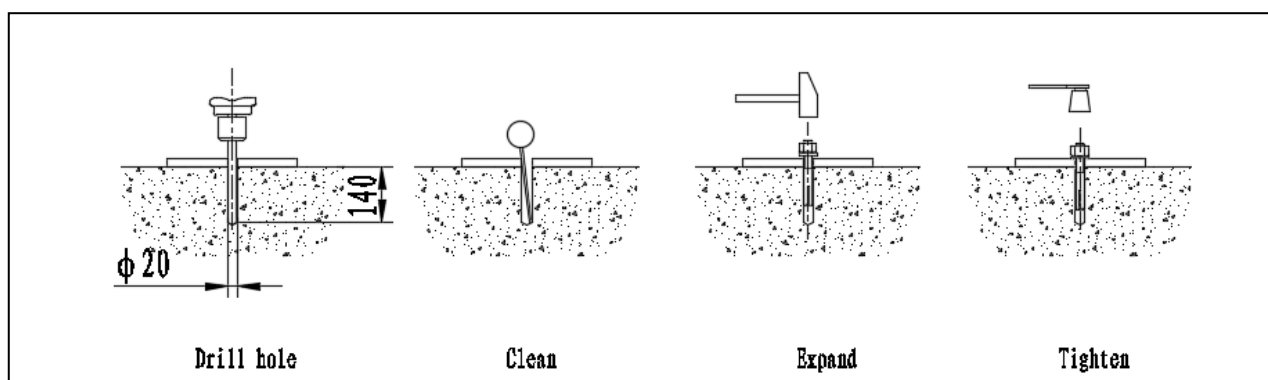

Picture 8

 **Notice:** Drill hole with $\phi 20$ mm aiguille and then anchor with pneumatic tools. The depth of hole and bolts should be the same and insert the bolt. The air anchor, made against the washer to under the post. When fastening to the use of torque wrench, do not use impact tools to tighten.

3.3 POSITIONING AND INSTALLATION OF THE STRUCTURE

 **WARNING:** At this stage of the installation, DO NOT perform any electrical connections.

3.3.1 POSITIONING AND FIXING OF THE COLUMNS

- 1) Remove the protection cartons of the packed lift and lay the components to be mounted on the floor, so as to work comfortably on the main structures.
- 2) Set the lift down in the area defined for installation, ensuring that there is sufficient ceiling height as indicated
- 3) Place the packing plates (picture 9) on the floor and remove the fastener screws.
- 4) After removing the packing plates (1 picture 9), keeping the columns in an upright position (2, picture 9) using appropriate supports and/or a lift truck, lift the columns (picture 10) and set both column plates P1 and P2 on the floor. Fasten with the relative screws (picture 7).
- 5) Drill seven 18 mm diameter holes for fastening the plates and the lift base (picture 8).
- 6) Fit the ten M20 anchor bolts (picture 7) tapping gently with a hammer.

7) To compensate for unevenness of the floor and render the structure more stable, insert washers under the structure.

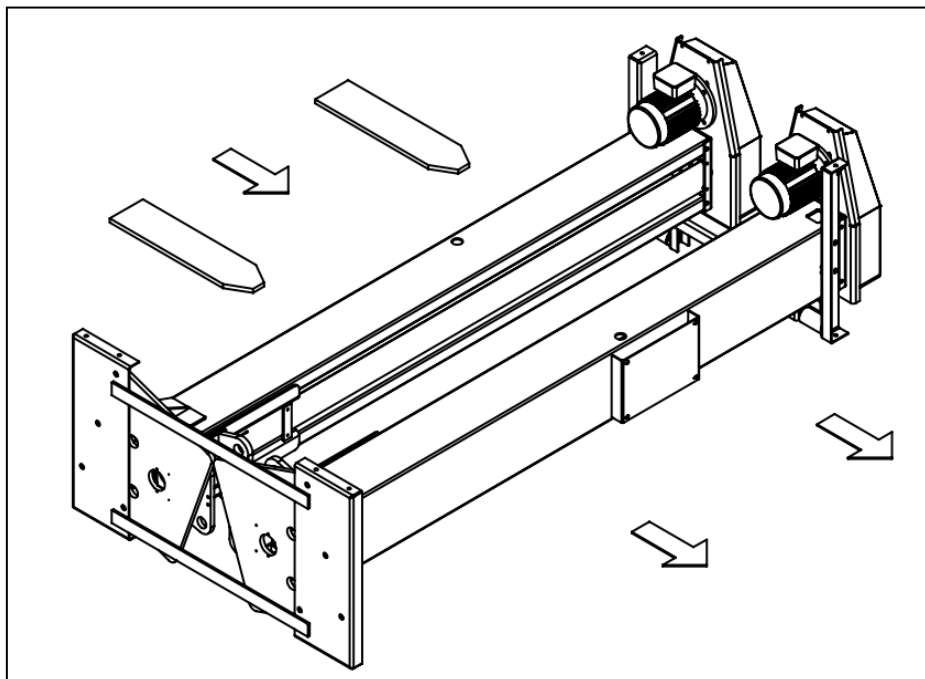

Picture 9

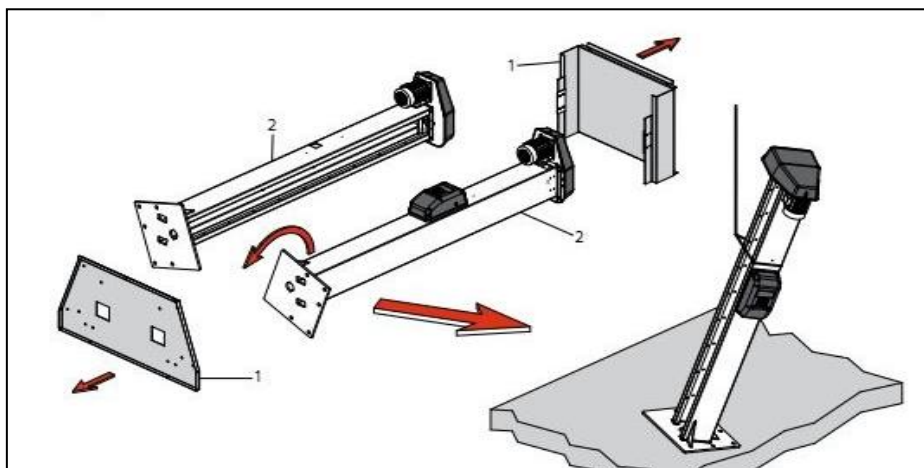

Picture 10

3.3.2 CARRIAGE ALIGNMENT

- Measure carriage height and check that any difference between the carriages does NOT exceed 4-5 mm; if needed, set carriages at the same height as follow:
- Adjust the carriage P1 by undoing and removing the parts 2, 6 and 7 shown in picture 11.
- Raise carriage P1 until the split nut (2, picture 12) becomes free to turn.
- Tighten the split nuts (1, 2, picture 12) clockwise or anticlockwise to compensate for any difference in carriage height. One full turn of a split nut displaces carriage by 6 mm.

 **WARNING: NEVER turn the splits nuts a fraction of a turn. Always turn through full turns so that the grease nipple will be facing outside afterwards.**

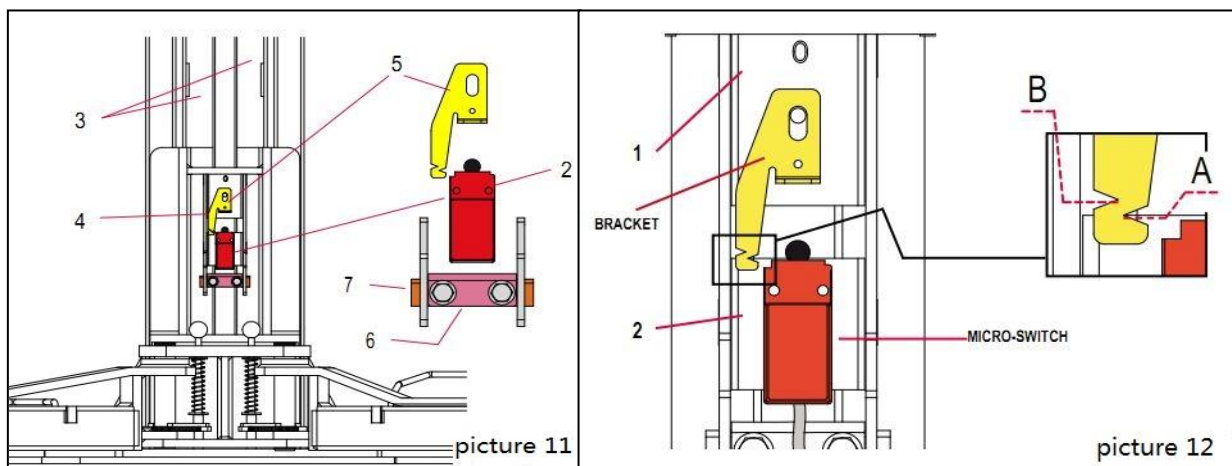

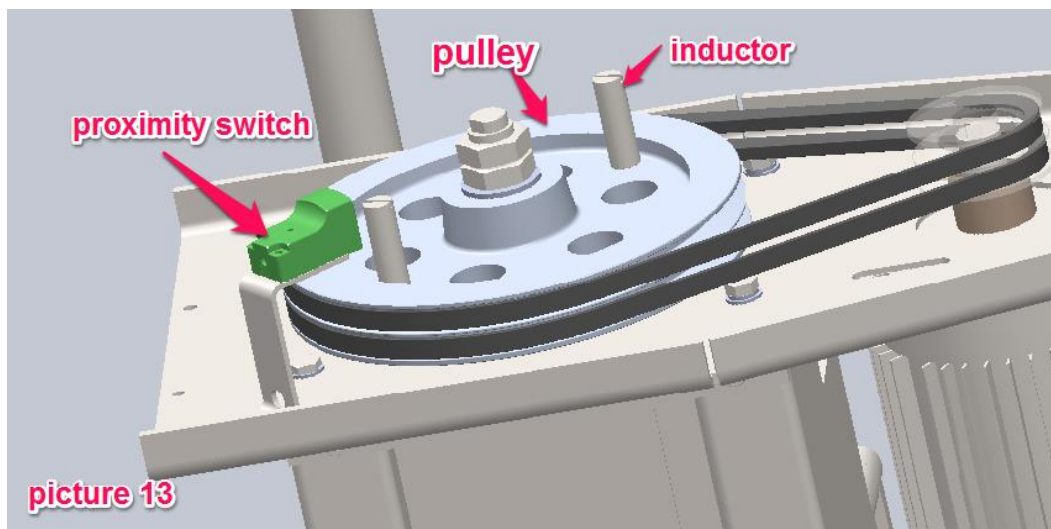

- 1) Secure the proximity switch and its support and adjust the distance between the proximity switch and inductor (picture 13).
- 2) Route the electric cables to the opposite column and connect to the circuit board in the order
- 3) Grease the drive pulley bearings and refit the column covers.

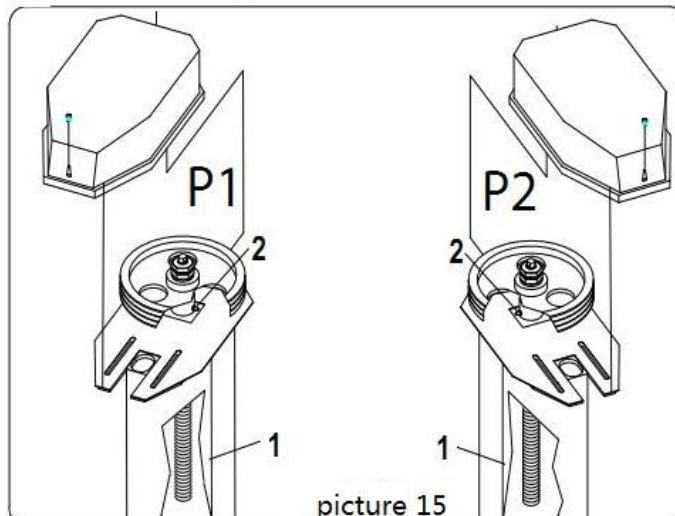
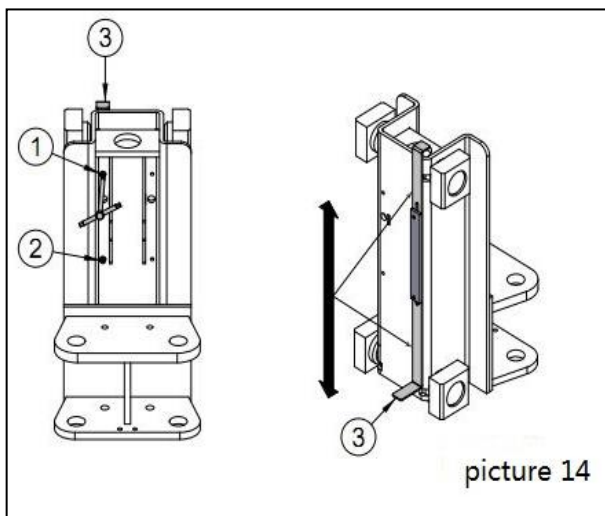



 **WARNING:** After the first up/down cycle, check that the threads of both screws are evenly lubricated. Repeat this operation whenever deemed necessary.

 **WARNING:** The lifting screws (1, picture 15) and the sliding surfaces of the carriage (3, picture 14) on the inner sides of the columns are greased in the factory with grease according to the specifications contained in the technical data.

 **WARNING:** Add oil or grease only as needed: too much grease will not ensure improved lubrication. Do not wash or use solvents on these surfaces. If needed, restore lubrication film using the type of grease specified in the "Technical Specifications Table". For ordinary maintenance, see the user's manual,

 **WARNING:** when the lift is working ,screw rod and screw nut are infused high temperature grease.

3.4 FIXING OF THREADING PIPE

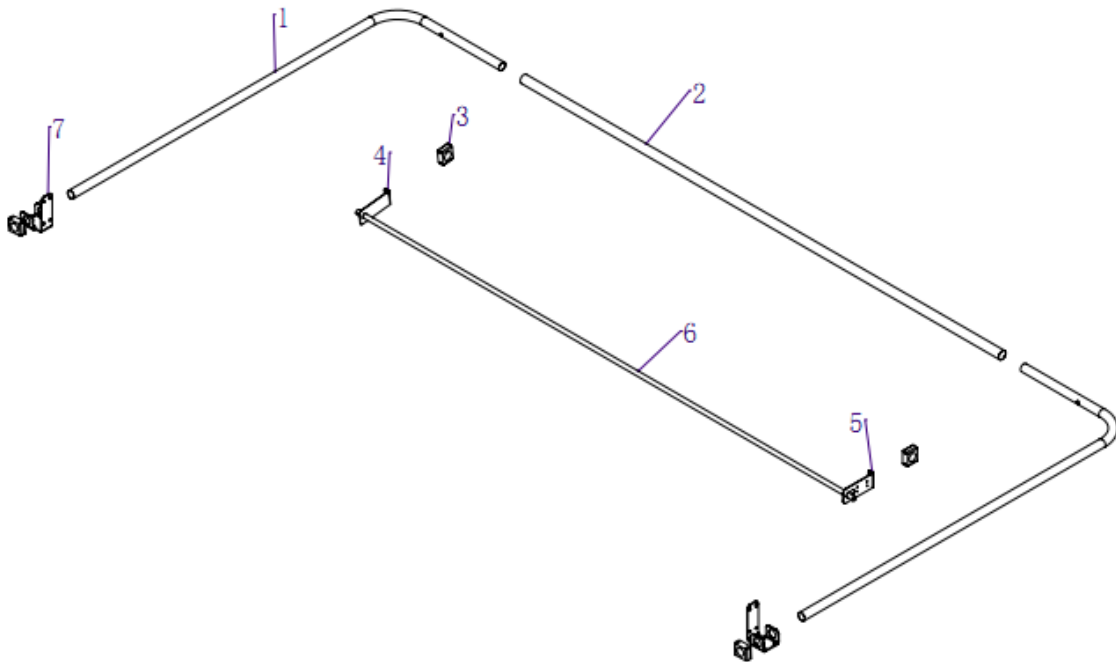

picture 16

1. Connect Thread of pipe (picture16-1) and 2 Support rods (picture16-2).
2. Fix Pipe clamp (picture16-3) and Anti-collision rod stents (picture16-4, picture16-5) to Thread of pipe.
3. Support rods through Pipe clamp and Fixed support (picture16-7).
4. Use a wire to pass the cable through Support rods and Thread of pipe.
5. Fix Fixed support on the column.
6. Raise Thread of pipe to the appropriate height, fix Pipe clamp.

3.5 CONNECTIONS TO THE ELECTRIC POWER NETWORK

3.5.1 ELECTRIC MOTOR CONNECTION

Connect the cable of the two columns to the control box as shown in the diagram in picture 17.

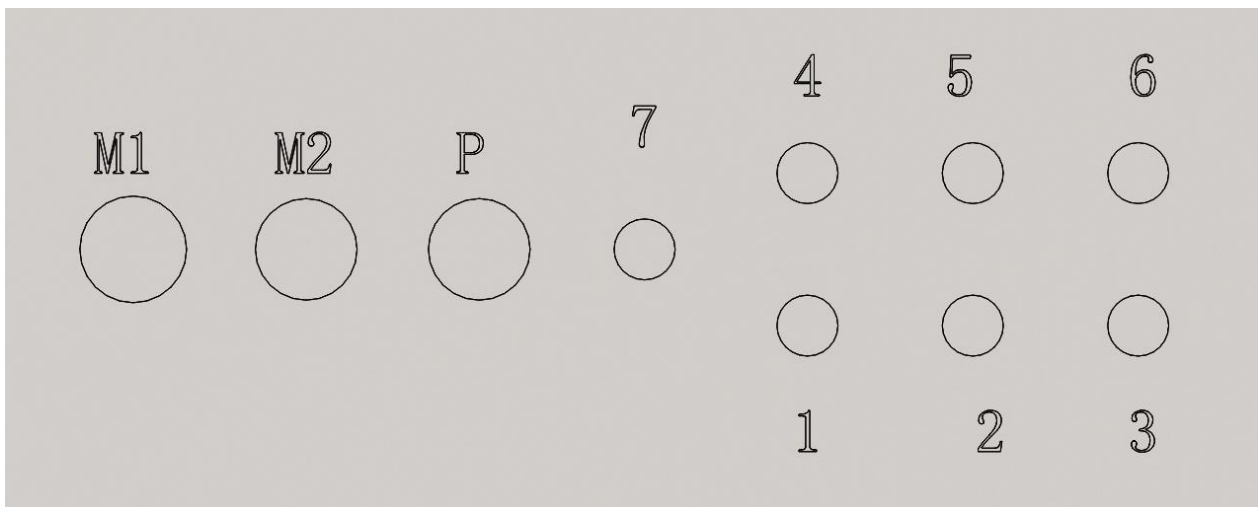

Picture17

- 1: Motor 1# (Main Column)
- M2: Motor 2# (Auxiliary column)
- P: Power
- 1-7: Limit Switch (Connect limit switches with the same number)



CAUTION:

- Lift electrical panel hook-up voltage shall correspond to the voltage value indicated on the electrical board.
- The electrical board shall already be connected to a main switch manufactured and installed in compliance with the National prevailing standards.
- Connect the power cable coming out of column1 top, to the electric power network in compliance with the prevailing national regulations.
- The system delivering power to the lift control panel shall be in compliance with the prevailing national standards.
- Min. needed power is 8 kW.
- The minimum permissible cross section of the wiring used for the power circuit is 4 mm .

3.5.2 SAFETY DEVICES SETUP AND ADJUSTMENT

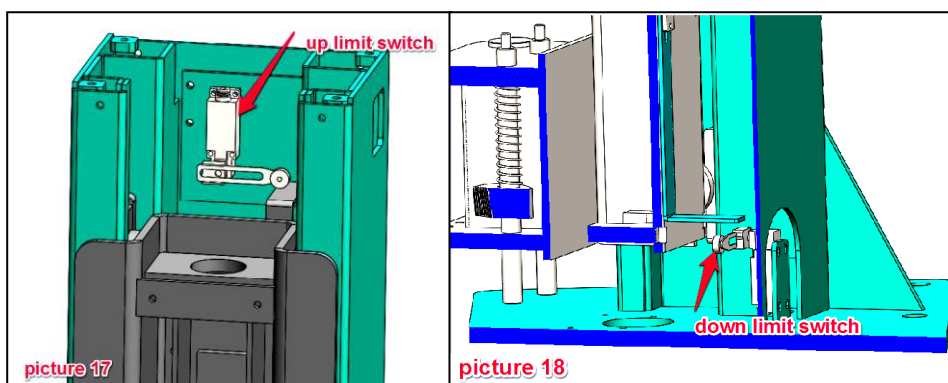

picture 17

- 1) Power on the line and check that the Emergency Switch/Disconnecter is in the ON (1) position.
- 2) Press the UP push-button. If the motor does not run, check that the mechanism is in the correct position.
- 3) Press the UP push-button, the carriages should rise. Should this not be the case, cut off power from the electric network, and reverse the two phases on the electrical plug of the power cable.



WARNING: Do not invert motor connections. This would affect limit switch operation.

- 4) Press the DOWN push-button and bring the carriages fully down. Check that the lower limit switch stops the motor before the lower edge of P1 carriage touches the floor.
- 5) Press the UP push-button and bring the carriages fully up. Check that the upper limit switch stops the motor when the carriages are approximately 50 mm away from the top column closure.
- 6) Fit the column covers (12-14, picture 1).

**WARNING**

The limit switch must stop the motor before the arms touch the floor and without activating the safety limit switch. The carriage alignment micro switch must activate when carriage misalignment exceeds 5 mm.

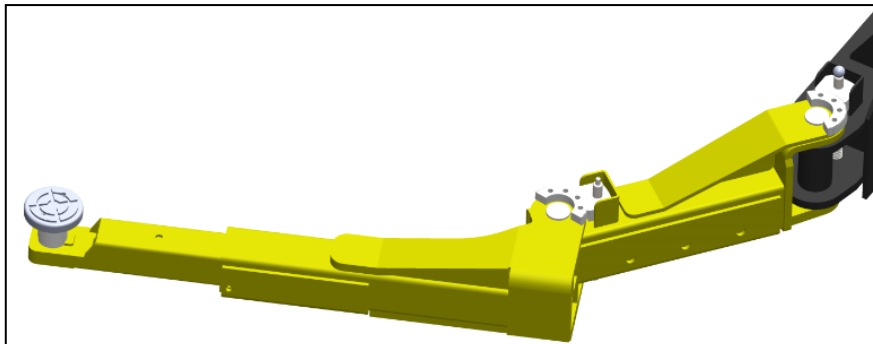
3.5.3 ARMS INSTALLATION

Picture 19

- Install the level 1 rocker arm on the carriage and then use the pin fix the level 1 rocker arm (picture19)
- Install the level 2 rocker arm on the level 1 rocker arm and then use the pin fix the level 2 rocker arm
- Then install the telescopic arm in the level 2 rocker arm and then install the screw to prevent sliding out

CHAPTER 4 INSTRUCTIONS FOR USE

WARNING: Do not invert motor connections. This would affect limit switch operation.



WARNING: Before carrying out any operation using the control panel, make sure that nobody is close to the lift.

4.1 CONTROL PANEL

All lift functions require the presence of an operator. Correct operator position is shown in picture 21. The operations to be carried out using the control panel are:

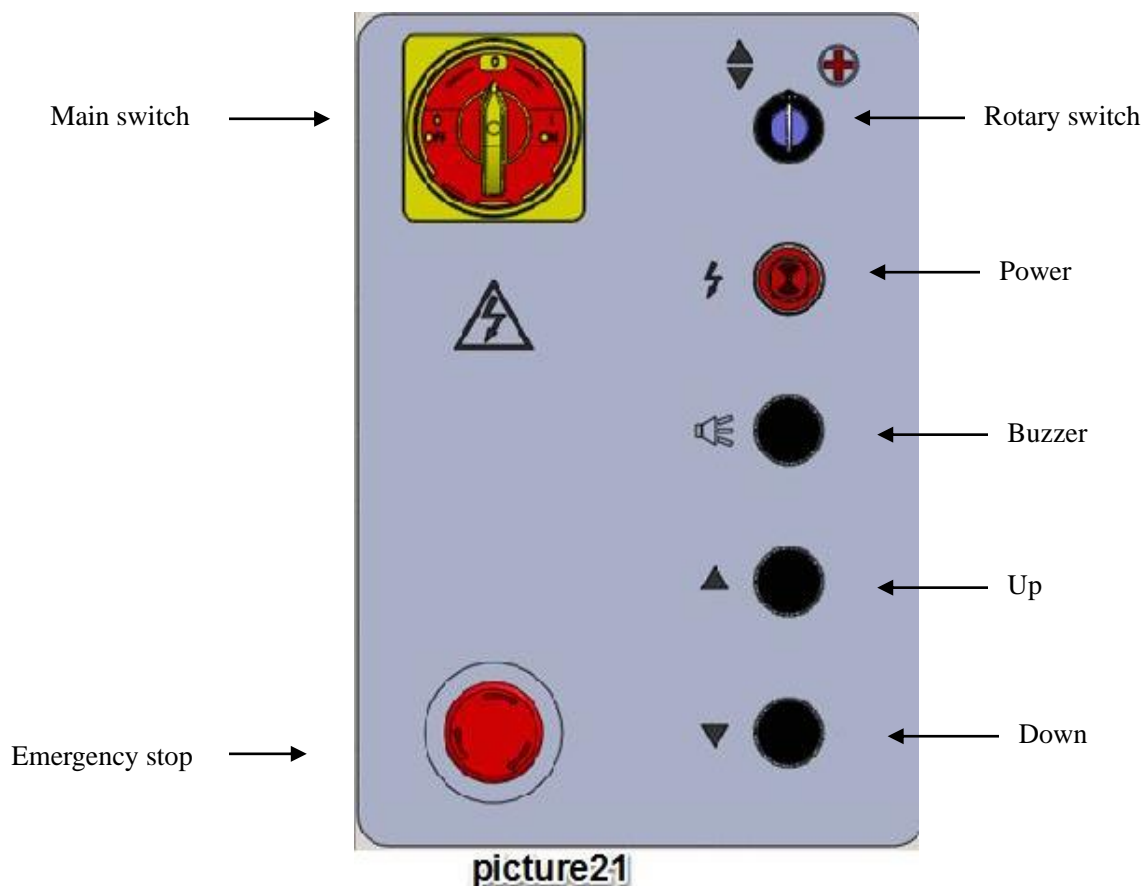

Installation and commissioning

After the lift is installed, it should be debugged according to the steps.

Step 1 power on check

A: the power indicator is always on.

B: IC board input port X4; X5; X6; X7 power indicator is on.

C: up limit check

Touch by hand column 1#2# any one of the upper limit switch X4 the light will be go out.

touch anti-collision switch X4 the light will be going out.

D: screw nut switch check

Touch by hand column 1#2#any one of the nuts switchX5 the light will be go out.

touch anti-collision switchX4 the light will be going out.

E: lower limit check

move by hand column 1#lower limit switchX6 will disappear.

move by hand column 2#lower limit switchX7 will disappear.

F: sensor check

use iron part close to the column 1# sensor X0 will shine.

use iron part close to the column 2# sensor X1 will shine.

Step 2 commissioning

The initial test platform is raised and lowered within the range of 30%-70% of the full stroke, best in the middle. Don't raise and lower to the limit.

A: turn the rotary switch to left, click "up" button, the two motors are synchronized rise; otherwise. .

decreasing motor is incorrect should be change the phase. click “down” button, direction;synchronize;the drop should be normal, otherwise ,power supply should be change the phase

B: turn the rotary switch to right. Down debugging respectively 1#;2#column. near the lower limit position should be slowed down.be sure to pay attention to the drop position. Otherwise, increase the lower limit switch position.do not hit the bottom to cause damage.

C: turn the rotary switch to left: Debug in the same way 1#;2# upper limit switch is normal.

D: pay attention to the whole process that rise and fall should be normal



WARNING:

1) the power indicator flashes as an alarm.

Press the up and down keys does not work when the alarm.

Reset mode only power off for 10 seconds, can be relieve after powering up again.

2) alarm content: any one of the counting sensors will not receive a sample alarm (no trigger) within 2 seconds of startup.

A: bad sensor or installation location is incorrect (sampling distance should be $\leq 5\text{mm}$) .

B: connection line break.

C: single motor work.

4.1.1 EMERGENCY SWITCH / DISCONNECTOR/OFF

- Turning Emergency Switch/Disconnecter to 0 (OFF), lift will stop working completely.
- This operation shall always be carried out before accessing the working area under the lift.
- Lift functions are enabled by turning Emergency Switch/Disconnecter back to 1 (ON).

Any failure or defect in one of more lifts parts, or any power supply circuit failure or malfunction will not result in hazardous situations, as the LIFT features

a power disconnecter for machine insulation. Up and down commands, in addition, are of the "dead man" type (hand-held). So, in case of power supply circuit failure, neither the accidental operation nor the stop prevention, and neither the load fall nor the safety devices inefficiency will be possible if the command has already been sent through the disconnecter.

During raising or lowering, lift moving parts are thus always stopped in case of power supply circuit failure. No hazardous situations will occur upon power supply circuit restore, as the operator will have to manually enable each single Lift movement using the hand-held control switch.

4.1.2 UP PUSH-BUTTON

- Check that the Emergency Switch/Disconnecter is set to 1 (ON) and turn it if necessary.
- Press the UP push-button until the desired height is reached.

4.1.3 DOWN PUSH-BUTTON

- Press the DOWN push-button until the desired height is reached.

4.2 LIFTING PROCEDURE

- It is forbidden to overload the lift. The lift may be used only for lifting loads within the load capacity,

The Manufacturer disclaims any and whatever liability for damages to persons, animals or property arising from noncompliance with the instructions given herewith and/or from an improper use of the lift or any use other than specified in this manual.

To lift the vehicle, proceed as follows:

- Check that the arms are turned towards the outside of the lift in a way that will not hamper the vehicle access between the columns.
- Place the vehicle between the lift columns.
- Turn the arms and pull out the extensions bringing the pads to the points designed for lifting the vehicle as indicated by the vehicle manufacturer.
- Check that the Emergency Switch is set to 1 (ON) and turn it if necessary.
- Press the UP push-button and lift the vehicle by 10 cm.
- Check the correct insertion of the rubber pads.
- Check vehicle stability.
- Press the UP push-button and lift the vehicle.
- Turn the Emergency Switch/Disconnecter to 0 (OFF) before accessing the working area.

4.3 LOWERING PROCEDURE

To lower vehicle, proceed as follows:

- Check that the Emergency Switch is set to 1 (ON) and turn it if necessary.
- Press the DOWN push-button until both carriages reach the minimum height.
- Turn Emergency Switch/Disconnecter to 0 (OFF).
- Turn the arms towards the outside of the lift in a way that will not hinder vehicle exit.
- Move the vehicle out of the lifting area.

4.4 SAFETY DEVICES



WARNING: The following safety devices shall by no means be tampered with or disabled; they shall also be always kept in top working conditions:

- "Dead-man" control panel: all the lift functions require the presence of an operator.
- Emergency Switch: if turned to 0 (OFF), it stops lift operation.
- The foot protection guards fitted to the arms prevent the risk of crushing of the operator's feet during the final stage of arm descent.
 - Arm anti-rotation mechanical safety locks with automatic engagement: prevent the rotation of the lifting arms when the carriage is lifted.
 - Back-up split nut on each carriage: supports load in the event of main split nut failure.
 - Minimum height limit switch and maximum height limit switch: they stop the motor to ensure that carriages will not run over the permitted stroke.
 - Safety device controlling carriage misalignment: this device uses the pulse circuit (REVOLUTION COUNTER) (picture 13) to prevent accidental carriage misalignment.
 - Low-voltage additional electric circuit: this circuit is electric shockproof.

**WARNING:**

The following operations shall be carried out only:

- When lift does not go down due to a power failure or in case of power cut-off.
- In case of absolute need.
- By a single qualified operator.
- If the lift area is delimited and made accessible to a single operator.

Lower the vehicle to ground manually by turning the lifting screws with a suitable wrench and following this procedure:

- 1) Disconnect the lift from the electric power network.
- 2) Check that no people, animals or things are in the hazardous area (squashing hazard).
- 2) Remove the pulley cover.
- 3) Apply a suitable wrench to the lifting screw and turn counter clockwise until lowering the vehicle to ground.

CHAPTER 5 MAINTENANCE AND CARE

Maintenance operations are listed hereinafter. A lower running cost and a longer machine life depend, among other things, on the constant execution of these operations.



CAUTION: The listed time schedule is given for information, and relates to standard operating conditions. It is susceptible of changes based on the type of service, level of environmental dusts, frequency of usage, etc...

In case of heavier conditions, maintenance operations shall be carried out more frequently.

5.1 SAFETY DEVICES CHECK (INSTALLER'S RESPONSIBILITY, BEFORE FIRST START-UP)

WARNING: The following operations should be carried out with unload lift.

5.1.1 EMERGENCY SWITCH

- 1) Check that the Emergency Switch/Disconnecter is set to 1 (ON) and turn it if necessary.
- 2) Press the UP/DOWN push-button.
- 3) At the same time, turn the Emergency Switch/Disconnecter to 0 (OFF) and the lifting arms should stop.

5.1.2 CHECKING THE SPLIT NUTS FOR WEAR

- 1) Bring the carriages at mid height along the columns.
- 2) Remove the column casings (12, picture 4). Check that the distance between the upper load-bearing lead screw (1, picture 12) and the lower safety load-bearing lead screw (2, picture 12) on both columns is between 23 and 24mm.
- 3) To check that the installation is correct, refer to the level of the plate. If the installation is correct, the top of the

lower safety lead screw (2 picture 12) must be at level A.



WARNING

When reference B is flush with the top face of the back-up split nut, it is necessary to replace the main split nut

5.1.3 MIN AND MAX HEIGHT LIMIT SWITCH CHECK

- 1) Press the DOWN push-button and bring the carriages fully down. Check that the lower limit switch stops the motor when the carriages are approximately 15 mm away from the base.
- 2) Press the UP push-button and bring the carriages fully up. Check that the upper limit switch stops the motor when the carriages are approximately 50 mm away from the top column closure.
- 3) If the carriages stop at any other position, adjust the position of the affected limit switch.

5.1.4 RUBBER-COATED PADS

Check their conditions. If worn-out or broken, change them.

The overall structure of the machine if serious damage or deformation cannot be used should be given scrapped.

5.2 regular maintenance

weekly	Check safety devices every week, as indicated in this manual
	Check that the ball bearings on the column ends are greased correctly and add regular grease if necessary
monthly	Clean the lift taking particular care to remove any foreign objects which may compromise the functionality of the mechanical and electric safety devices Warning: never use compressed air, pressurized water or aggressive chemical products to clean or remove residue from the machine
Every 3 monthly	Check that the anchor bolts fastening the machine to the ground are tightened to the correct torque and tighten if necessary, with a torque wrench. Check that all fastener screws and nuts are tightened to the correct torque and tighten if necessary, with a torque wrench. Grease the sliding shoes of the trolley with grease or an equivalent product.
Every 6 monthly	Grease the lead screws and split nuts with multifunctional lithium grease for general lubrication. Check that the tension of the chain is correct. Check all structural and mechanical components for faults or other problems

PROBLEMS	POSSIBLE CAUSES	ACTIONS
The lift does not work \ no reaction	Emergency switch set to off. Limit switch tripped Cable connections Burnt-out fuses	Set emergency switch back to on Check cause Check connections replace
When the up is pressed the lift does not run.	Max height limit switch tripped	check
Pressing the down button, the carriages do not go down	Min height limit switch tripped. Carriage is stuck	Check Check Raise the carriage and release it



DANGER:

It is strictly forbidden to operate or service the lift following any procedures other than those described in this manual or altering the safety devices or the electric system as this may involve a safety hazard for exposed persons.

If the above troubleshooting procedures do not help, do not attempt to solve the problem using makeshift methods; contact the manufacturer's service department.

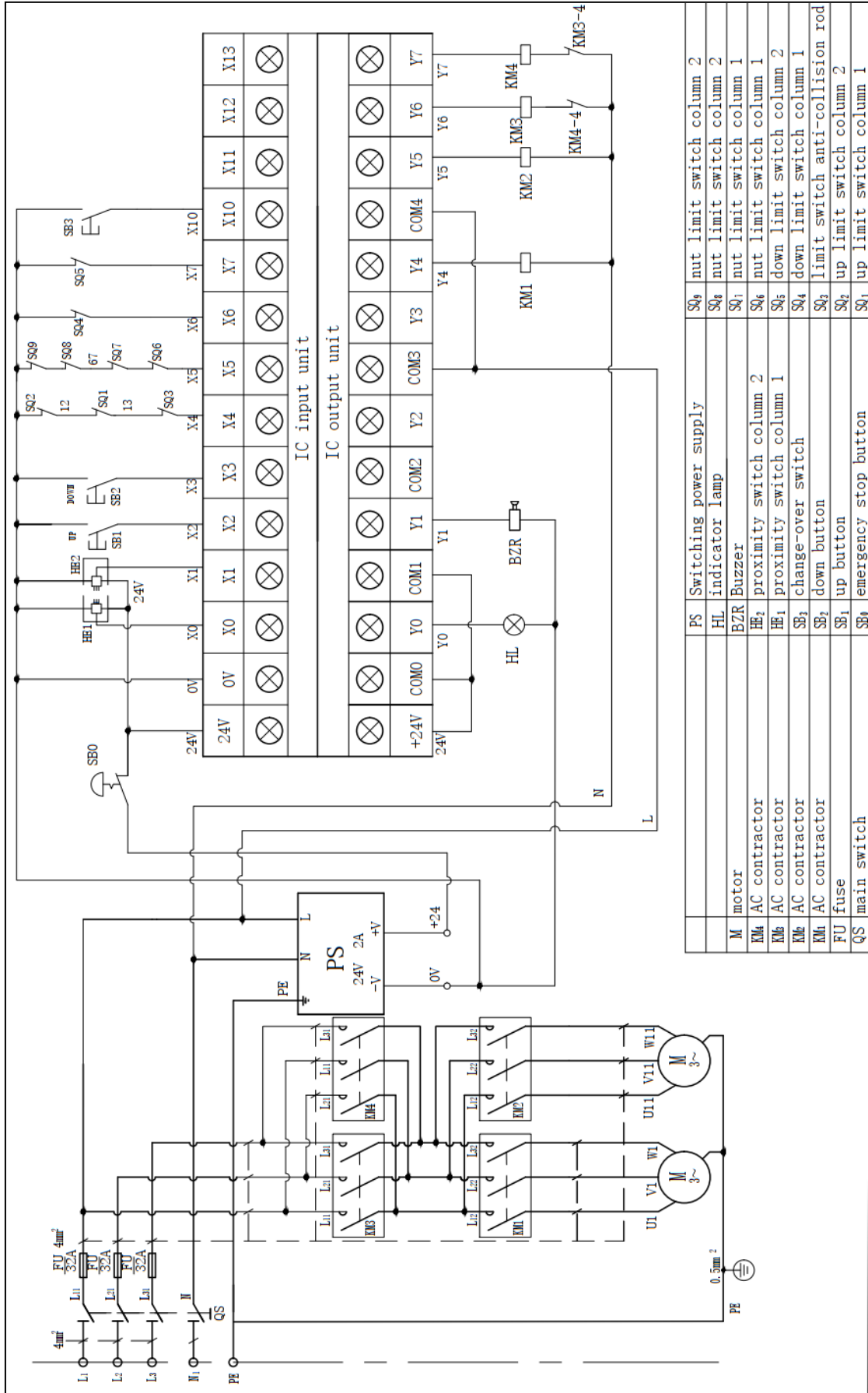

PS	Switching power supply	SQ9	nut limit switch column 2
HL	indicator lamp	SQ8	nut limit switch column 2
BZR	Buzzer	SQ1	nut limit switch column 1
M	motor	SQ0	nut limit switch column 1
KM4	AC contractor	SQ5	down limit switch column 1
KM3	AC contractor	SQ4	down limit switch column 2
KM2	AC contractor	SQ3	limit switch anti-collision rod
KM1	AC contractor	SQ2	up limit switch column 2
FU	fuse	SQ1	up limit switch column 1
QS	main switch		