

# Jema Autolifte A/S

**JA5500F**

**FOUR POST LIFT**

**Electrical Release**

## **INSTALLTION, OPERATION AND MAINTENANCE MANUAL**



Read this entire manual carefully and completely before installation and operation of the lift.

# INDEX

<b>1. Important safety instructions.....</b>	<b>5~7</b>
1.1 Important notices	
1.2 Qualified personnel	
1.3 Danger notices	
1.4 Warning signs	
1.5 Sound level	
1.6 Training	
<b>2. Overview of the lift.....</b>	<b>7~8</b>
2.1 General descriptions	
2.2 Construction of the lift	
2.3 Optional parts	
<b>3. Installation instructions.....</b>	<b>8~11</b>
3.1 Preparations before installation	
3.1.1 Tools and equipments needed	
3.1.2 A list for parts checking	
3.1.3 Ground conditions	
3.2 Precautions for installation	
3.3 Installation	
3.4 Items to be checked after installation	
<b>4. Operation instructions.....</b>	<b>12~15</b>
4.1 Precautions	
4.2 Descriptions of control box	
4.3 Flow chart for operation	
4.4 Operating instructions	
4.5 Emergency lowering in case of no power	
<b>5. Trouble shooting.....</b>	<b>17</b>
<b>6. Maintenance.....</b>	<b>18</b>
<b>7. Annex.....</b>	<b>19~39</b>
Annex1, Packing list of the whole lift	
Annex2, Overall diagram	
Annex3, Floor plan	
Annex4, Steel cable connection	
Annex5, Hydraulic working system	
Annex6, Wiring diagram	
Annex7, Separate diagrams for the lift	
Annex8, Spare parts list	
Annex9, Size and weight requirements on vehicles	
<b>8. CE Certificates and EC DECLARATION OF CONFORMITY.....</b>	<b>38~41</b>

# User's Records

Fill the following blanks with the information on the nameplate.

Model No. \_\_\_\_\_

Serial No. \_\_\_\_\_

Production Date \_\_\_\_\_

The following specially trained people are permitted to operate and maintain this lift.

- 1.
- 2.
- 3.
- 4.
- 5.
- 6.
- 7.
- 8.
- 9.
- 10.

# Installation Records

Model No. \_\_\_\_\_

Serial No. \_\_\_\_\_

Customer's Name: \_\_\_\_\_

Installation Date: \_\_\_\_\_

## Declaration

The above mentioned lift has been correctly installed and all its functions including the reliability of safety locks have passed strict tests. Therefore we hereby declare that this lift is in normal working condition when installation finished.

Installation date

\_\_\_\_\_

Installer's signature

\_\_\_\_\_

User's signature

\_\_\_\_\_

# 1. IMPORTANT SAFETY INSTRUCTIONS

## 1.1 Important notices

Jema autolifte A/S will offer one-year's quality warranty for the whole machine, during which any quality problem will be properly solved to the user's satisfaction. However, we will not take any responsibility for whatever bad consequence resulted from improper installation and operation, overload running or unqualified ground condition.

Users must always bear in mind that this lift is specially designed for lifting cars or other vehicles, so never use it for any other purposes. Otherwise, we, as well as our sales agency, will not bear any responsibility for accidents or damages of the lift.

Make sure to pay careful attention to the label of the lifting capacity attached on the lift and never try to lift cars with its weight beyond.

Read this manual carefully before operating the machine to avoid economic loss or personnel casualty incurred by wrong operation.

Without our professional advice, users are not permitted to make any modification to the control unit or whatever mechanical unit.

## 1.2 Qualified personnel

1.2.1 Only properly trained personnel can operate the lift.

1.2.2 Electrical connection must be done by a competent electrician.

1.2.3 People who are not concerned are not allowed in the lifting area.

## 1.3 Danger notices

1.3.1 Do not install the lift on any asphalt surface.

1.3.2 Read and understand all safety warnings before operating the lift.

1.3.3 Do not leave the controls while the lift is still in motion.

1.3.4 Keep hands and feet away from any moving parts. Keep feet clear of the lift when lowering.

1.3.5 Only properly trained personnel can operate the lift.

1.3.6 Do not wear unfit clothes such as large clothes with flounces, tires, etc, which could be caught by moving parts of the lift.

1.3.7 To prevent evitable incidents, surrounding areas of the lift must be tidy and with nothing unconcerned.

1.3.8 The lift is simply designed to raise the entire body of vehicles, with its maximum weight within the lifting capacity.

1.3.9 Always ensure the safety latches are engaged before any attempt to work near or under the vehicle. Never remove safety related components from the lift. Do not use if safety related components are damaged or missing.

1.3.10 Do not rock the vehicle while on the lift or remove any heavy component from vehicle that may cause excessive weight shift.

1.3.11 Check at any time the parts of the lift to ensure the agility of moving parts and the performance of synchronization. Ensure regular maintenance and if anything, abnormal occurs, stop using the lift immediately and contact our dealers for help.

1.3.12 Lower the lift to its lowest position and do remember to cut off the power source when service finishes.

1.3.13 Do not modify any parts of the lift without manufacturer's advice.

1.3.14 If the lift is going to be left unused for a long time, users are required to:

- a. Disconnect the power source.
- b. Empty the oil tank.
- c. Lubricate the moving parts with hydraulic oil.

**Attention: For environment protection, please dispose the disused oil in a proper way.**

## 1.4 Warnings (Read and understand all safety warnings before operation)

All safety warning signs attached on the lift are for the purpose of drawing the user's attention to safety operation. The labels must be kept clean and need to be replaced when they are worn-out or have dropped. Read the explanations of the labels carefully and try to memorize them.



## 1.5 Sound Level

The sound emitted from the lift should not exceed 75DB. For the sake of your health, we suggest putting a noise detector in your working area.

## 1.6 Training

Only properly trained people are allowed to operate the lift. We are quite willing to provide professional training for the users when necessary.

# 2. Overview of the lift

## 2.1 General descriptions

This four-post lift is generally composed by four posts, two beams, two platforms, a hydraulic oil cylinder and a set of power unit. It is driven by an electro-hydraulic system. Up and down of platforms is controlled by the to and fro movement of the oil cylinder. To ensure ultra safety of operators, it is equipped with mechanical safety locks in the four posts, which will automatically engaged in the process of lifting so as to prevent the platforms from sudden dropping down in case the hydraulic system fails to work.

Safety construction:

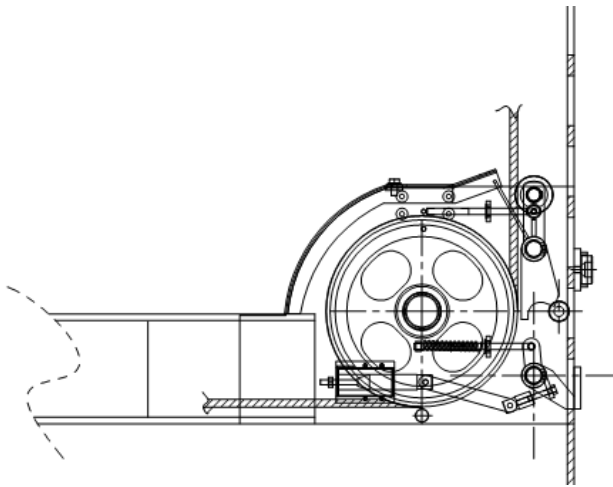

## 2.2 General construction of the lift

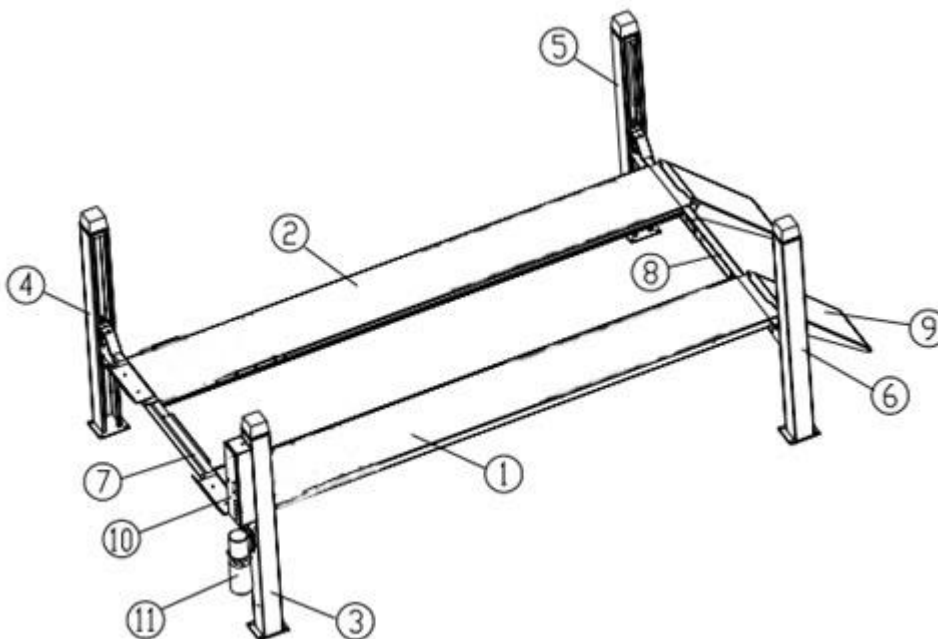

1. Platform A
2. Platform B
3. Main post 1
4. Post2
5. Post3
6. Post4
7. Main beam
8. Assistant beam
9. Ramps
10. Control box
11. Hydraulic pump

Weight for JA5500F = 1550 KG



## 2.3 Optional parts

### 1. Jacking beam light



## 3. Installation instructions

### 3.1 Preparations before installation

#### 3.1.1 Tools and equipments needed

- ✓ Appropriate lifting equipment
- ✓ Anti-abrasion hydraulic oil.
- ✓ Rotary Hammer Drill with 3/4" drill bit.
- ✓ Chalk and tape measure, magnetic plump, 8 meters  $\varnothing 15$  level pipe.
- ✓ Sockets and open wrenches, a set of inside hex wrenches, cross and straight screw drivers.
- ✓ Hammer, 4pounds, sharp nose pliers,  $\varnothing 17, \varnothing 19, \varnothing 22$  socket spanners.

#### 3.1.2 List for parts checking ---Annex 1 (Packing list)

Unfold the package and check if any parts missed as per Annex 1. Do not hesitate to contact us in case any parts missed, but if you do not contact us and insist installing upon the lack of some parts, Jema Autolifte A/S as well as our dealers will not bear any responsibility for this and will charge for any parts subsequently demanded by the buyer.

#### 3.1.3 Ground conditions

The lift should be fixed on a smooth and solid concrete ground with its strength more than 3000psi, tolerance of flatness less than 5mm and minimum thickness of 200mm. In addition, newly built concrete ground must undergo more than 28days' cure and reinforcement.

### 3.2 Precautions for installation

3.2.1 Make sure the four posts stand paralleled and are vertical to the ground. No slanting.

3.2.2 Joints of oil hose and steel cable must be firmly connected in order to avoid the looseness of steel cable and leakage of oil hose.

3.2.3 All bolts should be firmly screwed up.

3.2.4 Do not place any vehicle on the lift in the case of trial running.



### 3.3 Installation instructions

#### Step1: Choose a proper site

##### Location requirement

If not specifically stated, our lifts are only for indoor use. It should be fixed on a smooth and solid concrete ground. Do not install this lift on expansion beams of concrete or on a second or an elevated floor without first consulting building architect. Make sure that the space around or over the lift should be free of obstructions like heaters, building supports, electrical lines etc.

#### Step 2: Fix the installation layout

Once the installation site is determined, mark first the standing point of the four posts by a tape measure and chalk. Ensure two diagonal lines are of the same length.

#### Step 3: Remove the packing materials

1. Place some wooden battens on the ground and then use a crane to have the packing rack removed on to the battens so as to make its base is of some clearance from the ground.
2. Have the platforms of the lift suspended by a crane and then screw off the upside bolt and remove the first platform on to the wooden battens initially prepared.
3. Screw off the downside bolt and take away the packing rack on both sides.
4. Remove the shock absorption plastic film with a knife.

#### Step 4: Use a crane to have the general parts positioned in accordance with following layout.

For convenient installation, it would be better to pad something supporting under the platform.

Oil cylinder, steel cable and oil hose have already been fixed in the main platform before packing.

Wires rope, oil hose, safety lock etc, have already been fixed in the beams before packing.

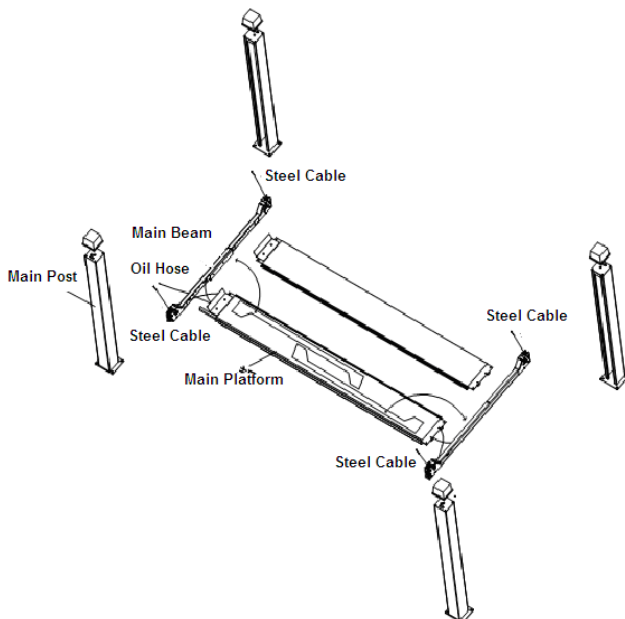

#### Step5: Connect the platforms and beams

Firstly, connect the main beam with two platforms. Align accurately the screw sockets on the platform and the beam. Installers can adjust the distance between two platforms on basis of practical needs. Once the distance was adjusted, fasten the beam and platforms with M12\*30 hex bolt with spring and flat washer padded. Connect the other beam in the same way.

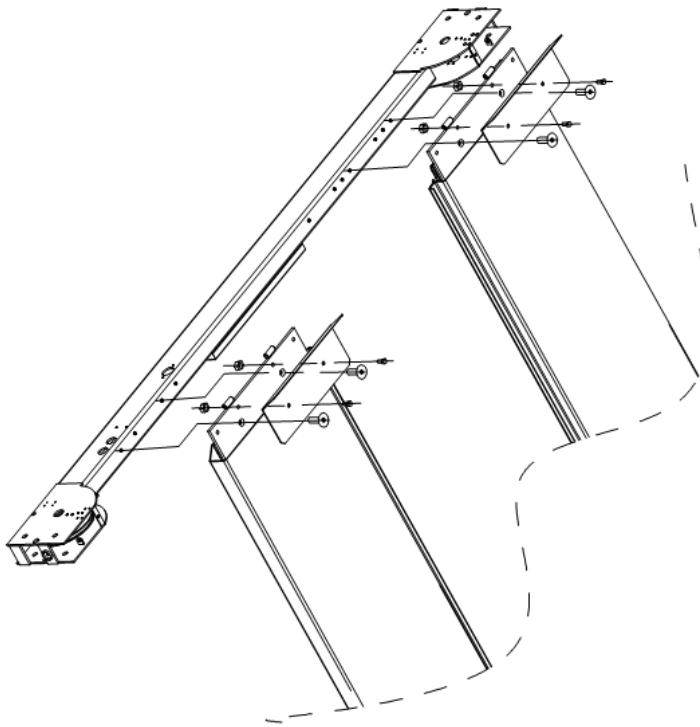

**Step6: Separately insert the four rods of safety teeth fixer into the four ends of cross beams.** Please refer to the diagram of safety construction and insert along the inside surface of the post's blanking plate. Have an M20 nut screwed on the end of the fixer which is to fix the rod of safety teeth fixer.

**Step 7: Elevate the post a bit and insert the bolt for fixing the safety teeth fixer into the diamond hole on the top of the main post and tighten it with a M20 screw.** Then plug the post into the beam and adjust the post and beam to a proper position. Pull the steel cable out and insert it through the reserved  $\Phi 21$  hole on the top of the post and then screw on the M20 nut.

**Step8: Fit on 8 nylon sliders (see the following diagram)**

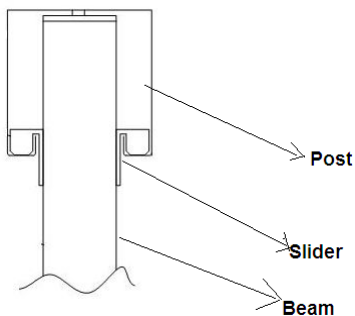

**Step9: Fix the ramps.**

Align the end of the platform and the hole on the ramp and connect them with shaft and cotter pins.

**Step10: Fit on four covers on top of the four post and four beam protectors at both ends of the two beams.**

**Step11: Mount the control box and hydraulic pump onto the main post.**

Pull out the oil hose and air hose (if applicable) from the main platform and have them connected to the hydraulic block. Fix the plate (on which the hydraulic pump will be fitted) on to the main platform by four M8\*20 bolts. (Four  $\Phi 9$  holes for the bolts are previously reserved). Then fix the hydraulic pump on to the plate by M10\*30 hex bolts, spring and flat washers.

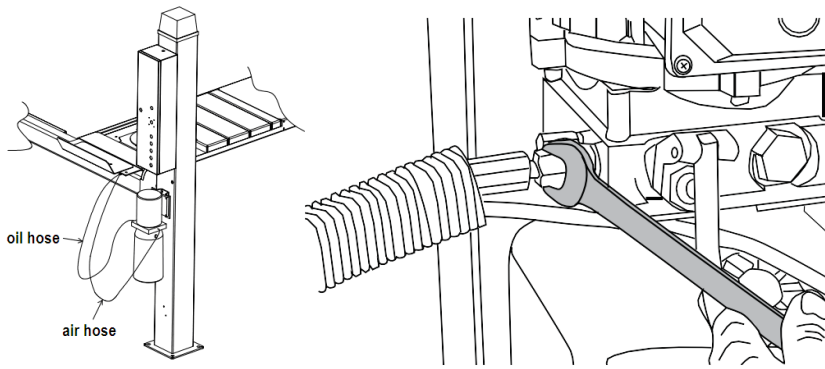

**Step 12: Connect the electrical system.**

**Attention:** electrical connection must be done by a licensed electrician.

Connect the wiring as per the wiring diagram and do pay careful attention to the number tubes attached on each thread of wire. Wires of with the same number shall be connected.

**Step 13: Mounting of top and bottom stop**

When top and bottom stops are mounted in the main post, it is important that they are mounted correctly as otherwise they can break when the lift is tested. See picture below how to place them in the main post. Also remember to adjust the arm on the top and bottom stops.



**Bottom stop**



**Top stop**

**Step 14: Leveling**

No vehicle on platforms when leveling.

Switch on and press the UP button when the green power indicating light is on. When the steel cable has been tightened, measure if the two platforms are of the same height from the ground. If not, adjust the tightening screw fixed on top of the main post.

**Step14: Fix the expansion plug.**

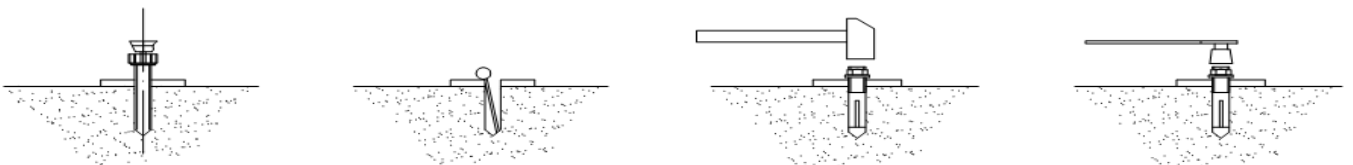

### 3.4. Items to be checked after installation.

S/N	Check items	YES	NO
1	Are the posts vertical to the floor?		
2	Is the oil hose well connected?		
3	Is the steel cable well connected?		
4	Are two platforms well connected?		
5	Are electrical connections, right?		
6	Are the rest joints firmly screwed?		
7	Are all items need lubricating added with grease?		

## 4. Operation instructions

### 4.1 Precautions

4.1.1 Check all the joints of oil hose. Only when there is no leakage, the lift can start work.

4.1.2 The lift, if its safety device malfunctions, shall not be used.

4.1.3 The machine shall not lift or lower an automobile if its center of gravity is not positioned midway of the platforms. Otherwise, the Jema Autolifte as well as our dealers will not bear any responsibility for any consequence resulted thereby.

4.1.4 Operators and other personnel concerned should stand in a safety area during lifting and lowering process.

4.1.5 When the platforms rise to the desired height, switch off the power at once to prevent any mal operation done by unconcerned people.

4.1.6. Make sure the safety lock of the lift is engaged before start working under the vehicle and no people under the vehicle during lifting and lowering process.

### 4.2 Descriptions of control box

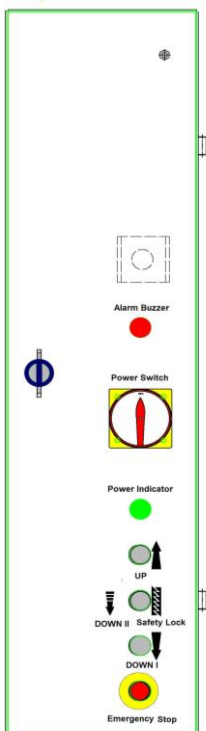

Description	Function
Alarm buzzer	Low height alarm
Power switch	Control power connection
Power indicator	Show if power is connected
UP button	Control the UP movement
Safety lock	Safety lock engaged
DOWN I button	Control down movement
DOWN II button	Control down movement
EMG.Stop	Ensure safety in emergency conditions

### 4.3 Flow chart for operation

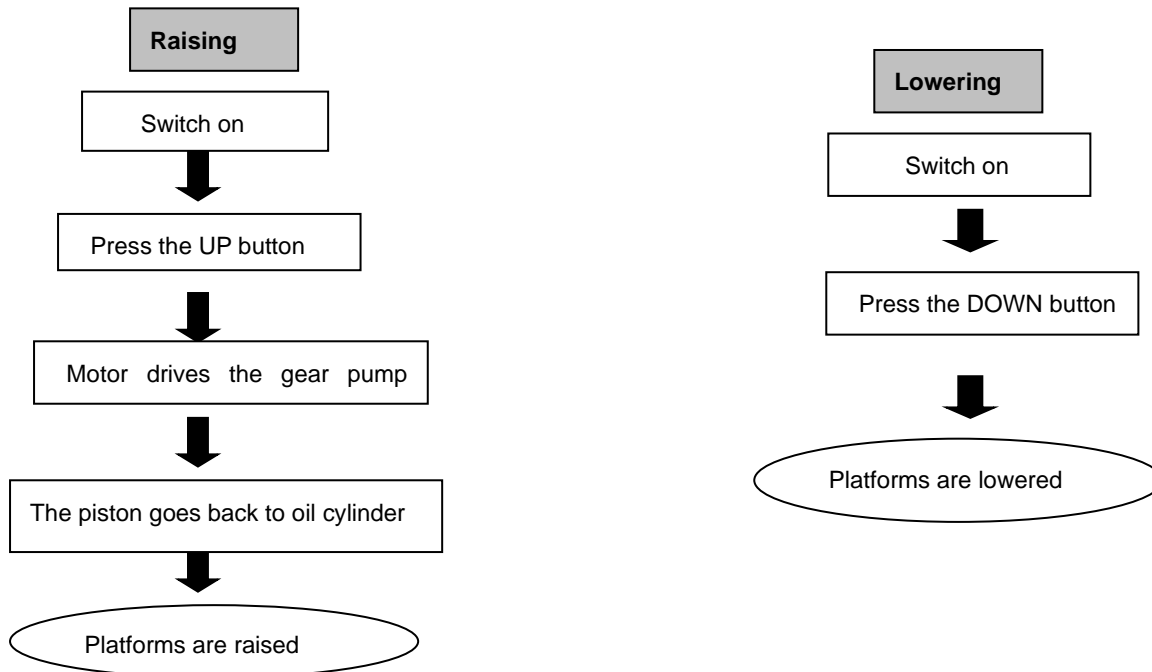

### 4.4 Operation instructions

#### **Raise the lift**

1. Make sure that you have read and understood the operation manual before operation.
2. Park the vehicle on the platforms to ensure its gravity is positioned midway of the platforms.
3. Switch on. When the power indicator is on, press the UP button until platforms rise to the desired height.
4. Before performing any service around or under the vehicle, operators must press the safety lock button to ensure the mechanical safety lock is fully engaged, turn off the power so as to avoid any wrong operation done by irrelevant personnel and check again the stability of the vehicle.

#### **Lower the lift**

1. Switch on. When the power indicating light is on, press the DOWN I and DOWN II button and then platforms of the list will go down gradually.
2. Drive away the vehicle when platforms have lowered to the lowest position.
3. Turn off the power.

## 4.5 Emergency lowering in case of no power

### In the case the safety lock is not fully engaged:

1. Push the front rod of the four electric magnets under the cross beam to have the four safety blocks released from the safety rods.

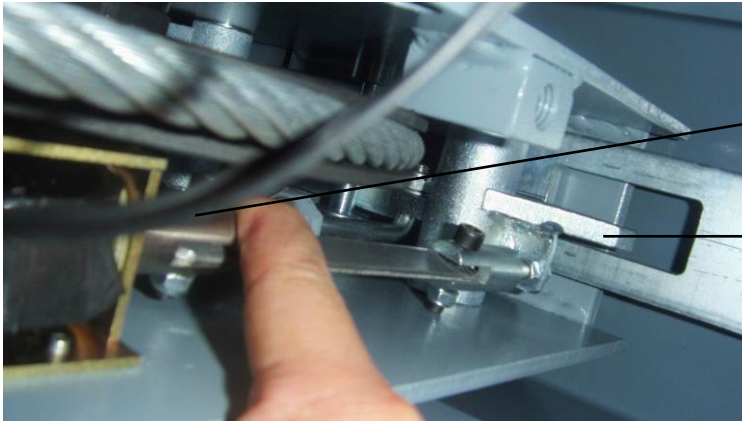

Front rod of electric magnet

Safety block and safety rod

2. Press and screw loose counter-clockwise the unloading valve to lower the platform.

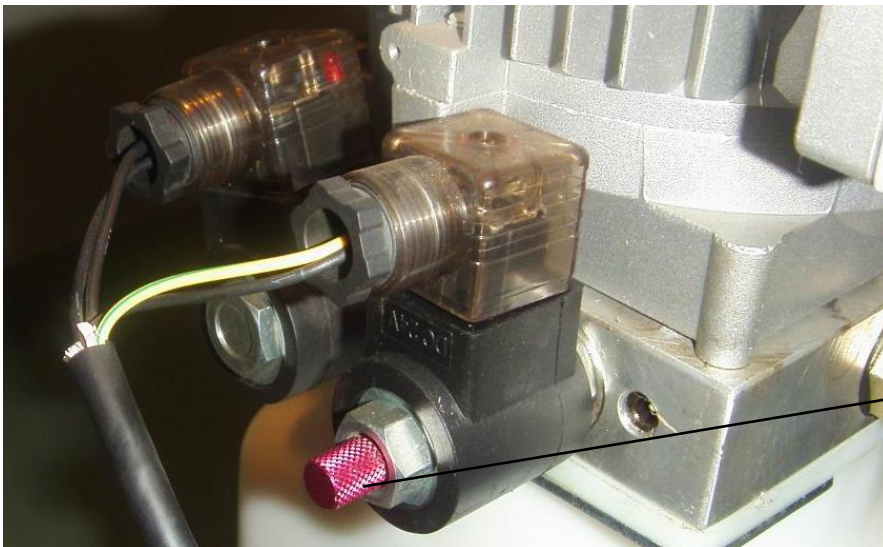

Unloading valve

### In the case the safety lock is fully engaged:

1. Remove the fitting as show in the following pictures and connect the tie-in with hand pump. Pull and push the handle of the hand pump to supplement oil to the oil cylinder so as to have the safety teeth released.



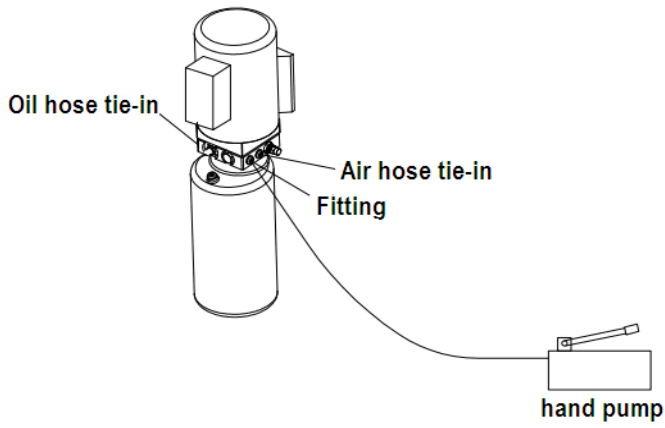

2. Push the front rod of the four electric magnets under the cross beam to have the four safety blocks released from the safety rods.

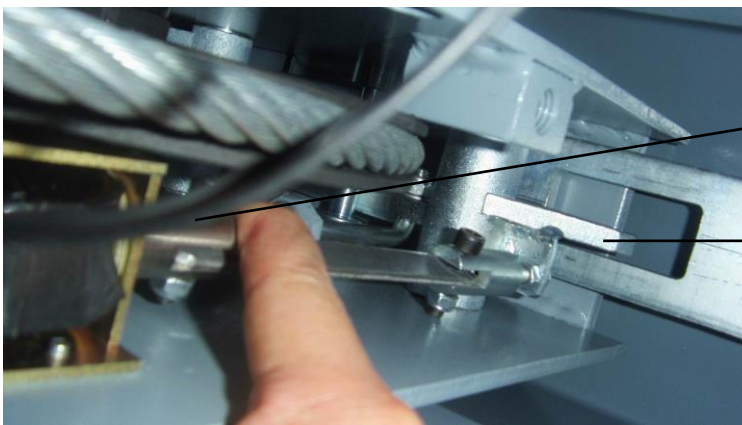

Front rod of electric magnet

Safety block and safety rod

3. Press and screw loose counter-clockwise the unloading valve to lower the platform.

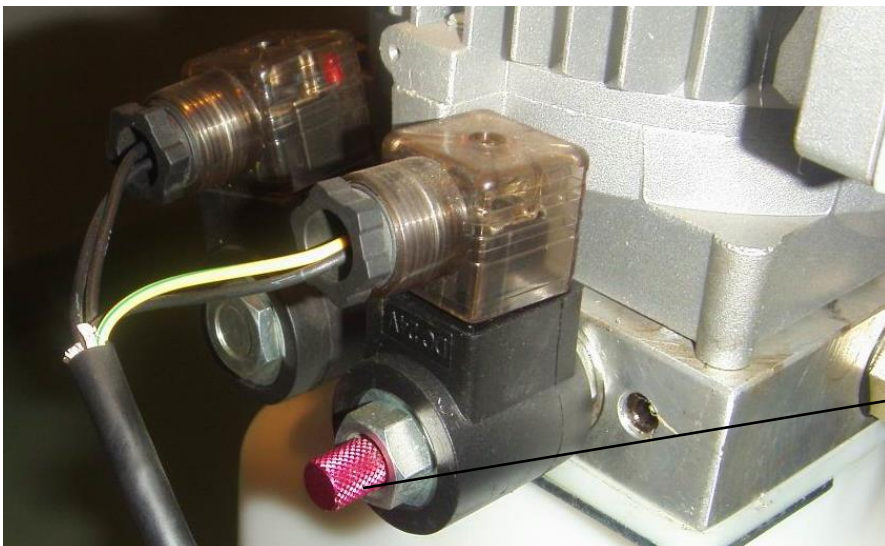

Unloading valve

## 5. Trouble Shooting

**ATTENTION:** If the trouble could not be fixed by yourself, please do not hesitate to contact us for help. We will offer our service at the earliest time we can. By the way, your troubles will be judged and solved much faster if you could provide us more details or pictures of the trouble.

TROUBLES	CAUSE	SOLUTION
Abnormal noise	Abrasion exists on insides surface of the posts.	Grease the inside of the post.
	Trash in the post.	Clear the trash
Motor does not run and will not rise	The wire connection is loose.	Check and make a good connection.
	The motor is blown.	Replace it.
	The limit switch is damaged, or the wire connection is loose.	Connect it or adjust or replace the limit switch.
Motor runs but will not rise	The motor run reversely.	Check the wire connection.
	Overflow valve is loose or jammed.	Clean or adjust it.
	The gear pump is damaged.	Replace it.
	Oil level is too low.	Add oil.
	The oil hose became loose or dropped off.	Tighten it.
	The cushion valve became loose or jammed.	Clean or adjusts it.
Platforms go down slowly after being raised	The oil hose leaks.	Check or replace it.
	The oil cylinder is not tightened.	Replace the seal.
	The single valve leaks.	Clean or replace it.
	The overflow valve leaks.	Clean or replace it.
	Manual unloading valve or electrical unloading valve leaks.	Clean or replace it.
Rising too slow	The oil filter is jammed.	Clean or replace it.
	Oil level is too low.	Add oil.
	The overflow valve is not adjusted to the right position.	Adjust it.
	The hydraulic oil is too hot (above 45°) .	Change the oil.
	The seal of the cylinder is abraded.	Replace the seal.
	Inside surface of the posts is not well greased.	Add grease.
Lowering too slow	The throttle valve jammed.	Clean or replace.
	The hydraulic oil is dirty.	Change the oil.
	The anti-surge valve jammed.	Clean it.
	The oil hose jammed.	Replace it.
The steel cable is abraded	No grease when installation or out of lifetime	Replace it.



## 6. Maintenance

Easy and low-cost routine maintenance can ensure the lift work normally and safely. Following are requirements for routine maintenance. You may decide the frequency of routine maintenance by consulting your lift's working conditions and time.

S/N	Name
1	Slider
2	Steel cable
3	Side slider
4	Sliding wheel
5	Safety block A1(A2)
6	Safety block B1(B2)
7	Spring
8	Shaft

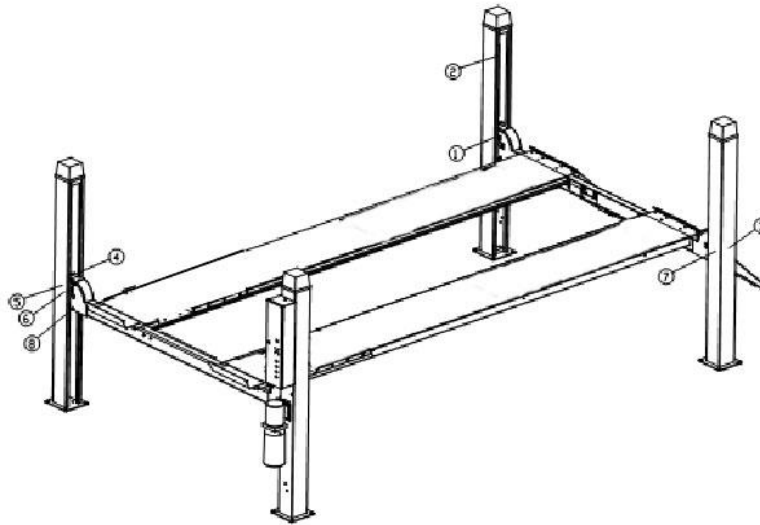

THE FOLLOWING PARTS NEED TO BE LUBRICATED

### 6.1 Daily checking items before operation

The user must perform daily check. Daily check of safety latch system is very important – the discovery of device failure before action could save your time and prevent you from great loss, injury, or casualty.

- Before operation, judge whether the safety latches are engaged by sound.
- Check whether oil hose well connected and whether it leaks or not.
- Check the connections of chain and steel cable and check the power unit.
- Check whether plug bolts firmly screwed.
- Check if safety teeth and safety block matched well or not.

### 6.2 Weekly checking items

- Check the flexibility of moving parts.
- Check the working conditions of safety parts.
- Check the amount of oil left in the oil tank. Oil is enough if the carriage can be raised to highest position. Otherwise, oil is insufficient.
- Check whether plug bolts firmly screwed.

### 6.3 Monthly checking items

- Check whether plug bolts firmly screwed.
- Check the tightness of the hydraulic system and screw firm the joints if it leaks.
- Check the lubrication and abrasion circumstance of axial pins, carriages, lifting arms and other related parts and replace in time with new ones if they failed to work well.
- Check the lubrication and abrasion circumstance of steel cable.

### 6.4 Yearly checking items

- Empty the oil tank and check the quality of hydraulic oil.
- Wash and clean the oil filter.

**If users strictly follow the above maintenance requirements, the lift will keep in a good working condition and meanwhile accidents could be avoided to a large extent.**

## 7. Annex

### Annex1: Packing list of the whole lift

S/N	Name	Drawing#/size	Qty
1	Main platform	JA4000FN-A4	1
2	Assistant platform	JA4000FN-A5	1
3	Beam A	JA4000FM-A2	1
4	Beam B	JA4000FM-A7	1
5	Ramp A	JA4000FN-A8	2
6	Ramp B	JA4000FN-A10	2
7	Post	JA4000FN-A1-B1	4
8	Post	JA4000FN-A6-B1	
9	Bar for safety lock	JA4000FN-A1-B2	4
10	Control box	JA4000FC	1
11	Pump	JA4000FM-A3-B33	1
12	Slider	JA4000FN-A2-B3	8
13	Slider holder	JA4000FN-A2-B2	8
14	Manual rod	JA4000FM-A29	1
15	Pump assembly holder	JA4000FN-A13	1
16	Protector	JA4000FN-A2-B5	4
17	Post cover	JA4000FN-A11	4
18	Shaft	JA4000FN-A8-B2	2
19	Handle	JA4000FM-A26	1
20	Handle fixer	JA4000FM-A27	1
21	Reset plate	JA4000FM-A28	1
22	Hex bolt	M12*25	12
23	Hex bolt	M10*30	5
24	Hex bolt	M8*15	16
25	Spring washer	Φ12	8
26	Spring washer	Φ10	4
27	Flat washer	Φ12	8
28	Nut	M10	5
29	Nut	M12	4
30	Nut	M20	16
31	Open pin	3*40	4
32	Flat washer	Φ10	4
33	Flat washer	Φ8	16
34	Cross round headed bolt	M5*10	4
35	Cross round headed bolt	M6*12	2
36	Cross round headed bolt	M6*30	1

Annex2: Overall diagram

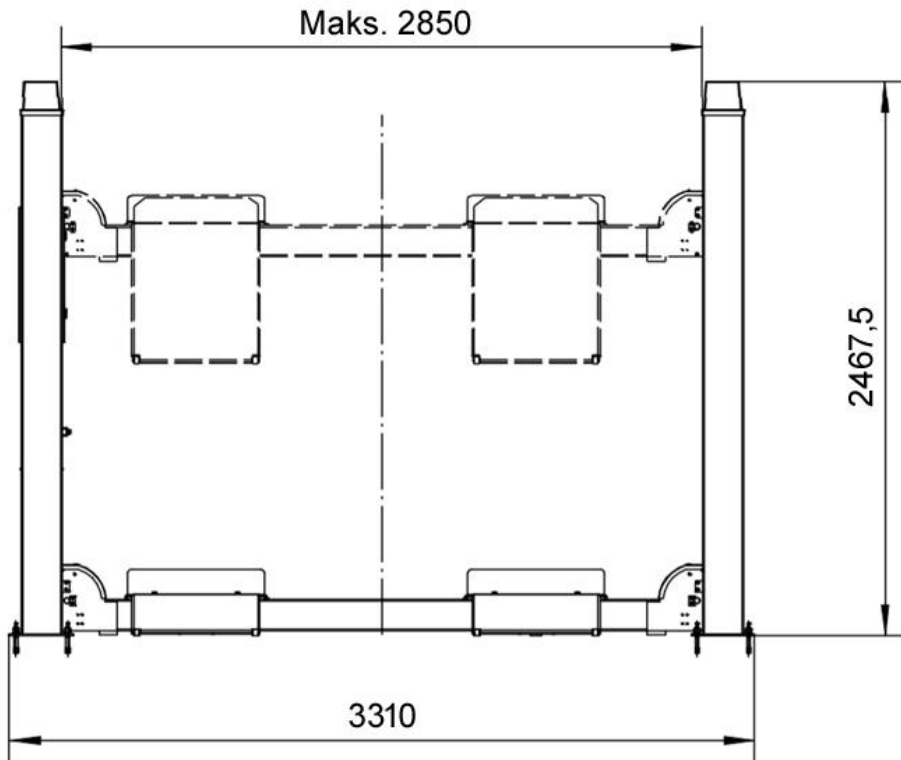
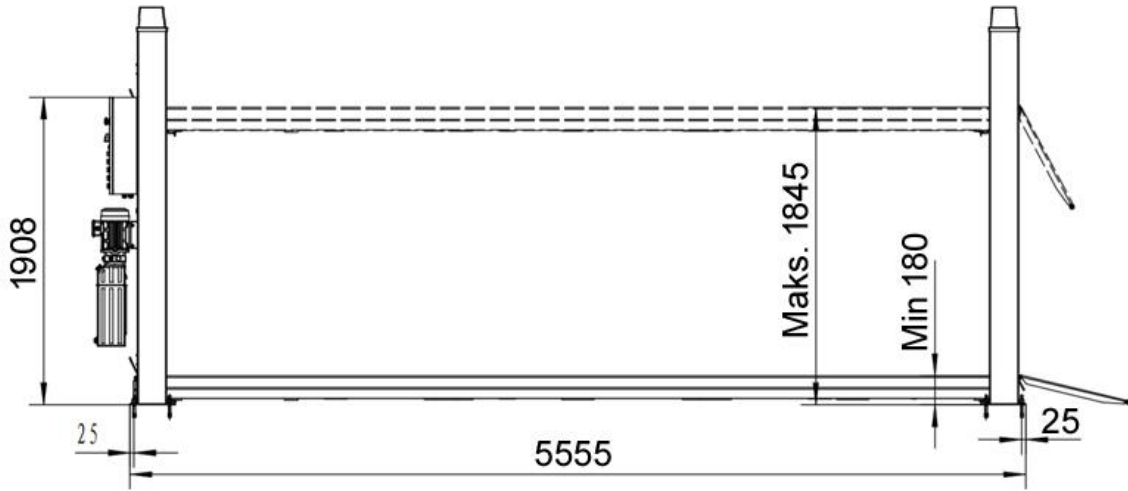

### Annex3: Floor plan

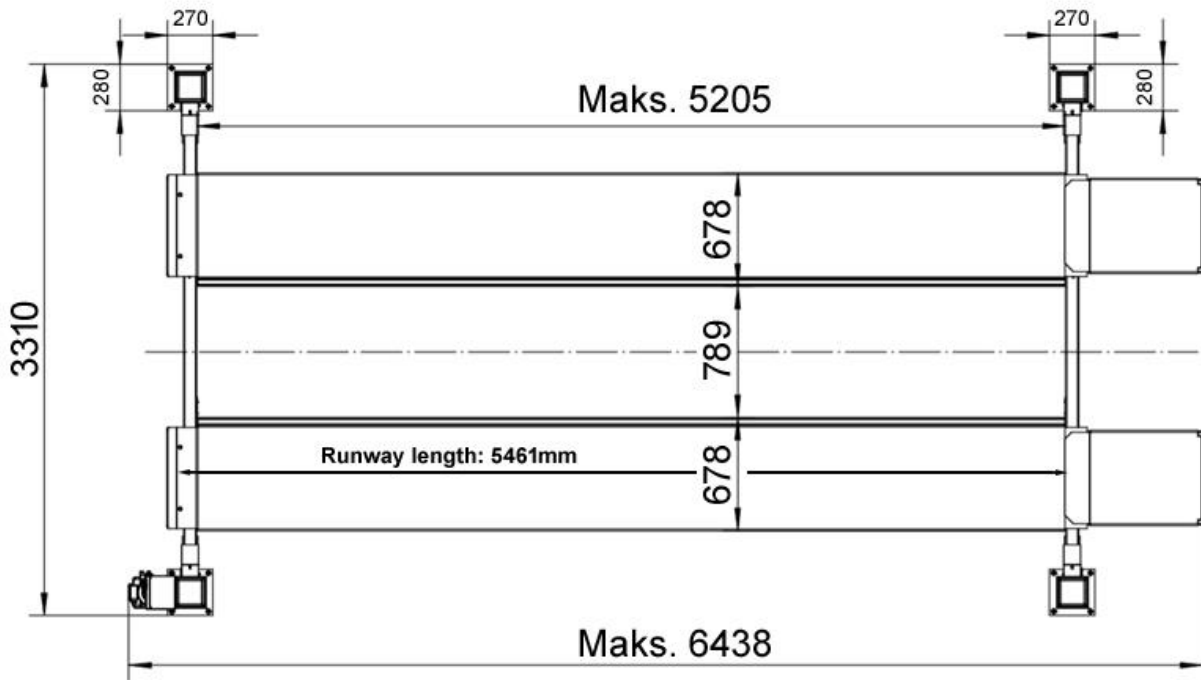

### Annex 4: Steel cable connection

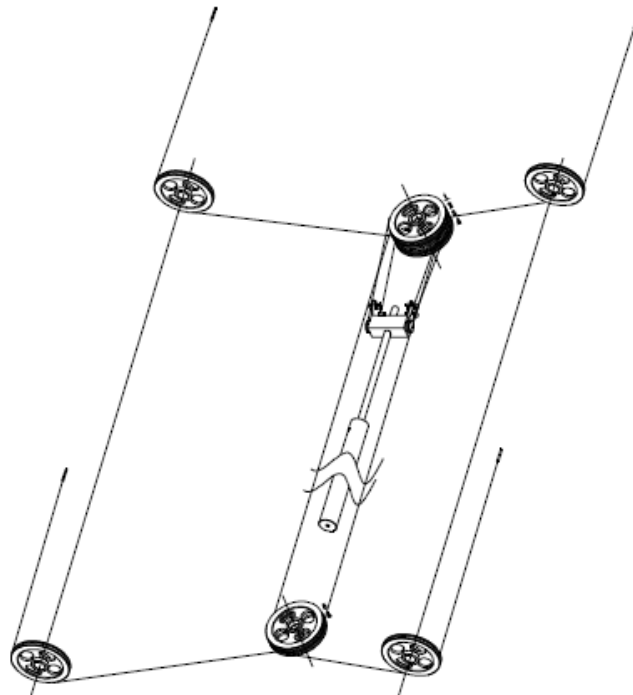

## Annex 5: Hydraulic working system

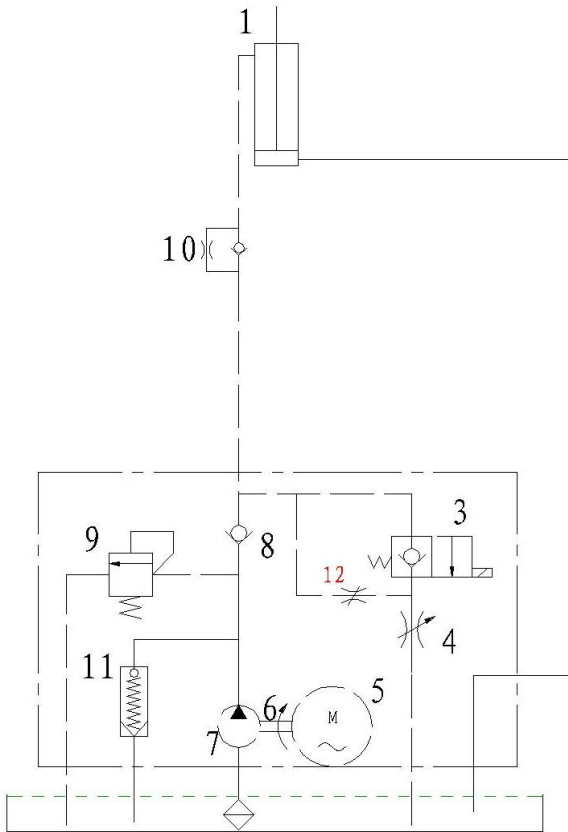

1. Oil cylinder
3. Electrical unloading valve
4. Throttle valve
5. Motor
6. Coupling
7. Gear pump
8. One way valve
9. Overflow valve
10. Anti-surge valve
11. Cushion valve
12. Emergency unloading valve

# Annex 6: Wiring diagram Three phase

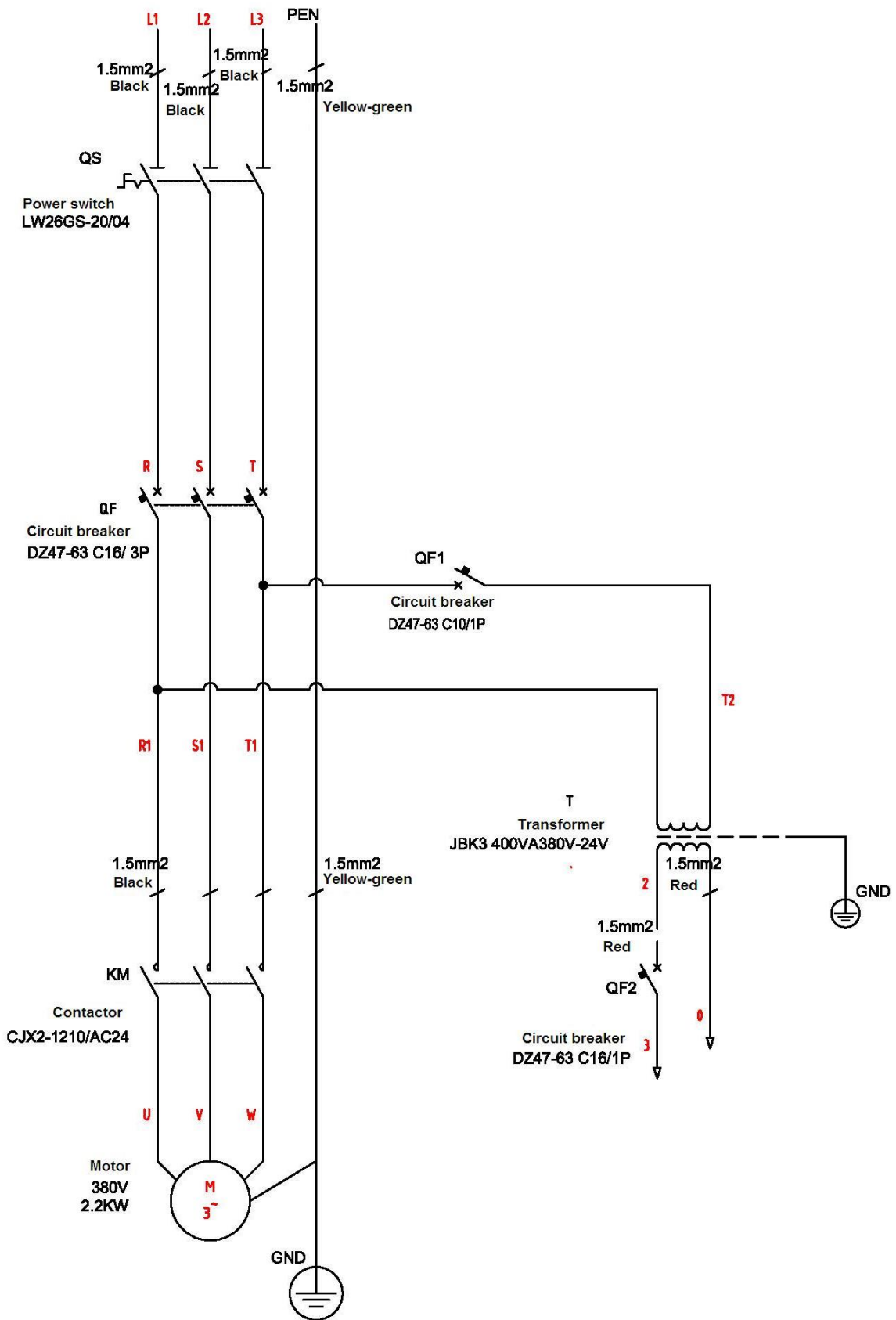

## Electric wire connections in control box:

	MAIN POWER																OPERATION MOTOR				
Wire No.	PE	L1	L2	L3	4	6	5	0	5	0	8	0	6	13	14	16	11	U	V	W	PE
Climbing No.	1	2	3	4	5	6	7	8	9	10	11	12	13	14	15	16	17	18	19	20	21
Connection		L1	L2	L3	BEAM LIMIT			ELECTRIC MAGNET			TOP STOP		BOTTOM STOP		LOWERING VALVE						
Function					NC	NC					NC	NC	/	NC	NO						

## Picture of the control box and connections:

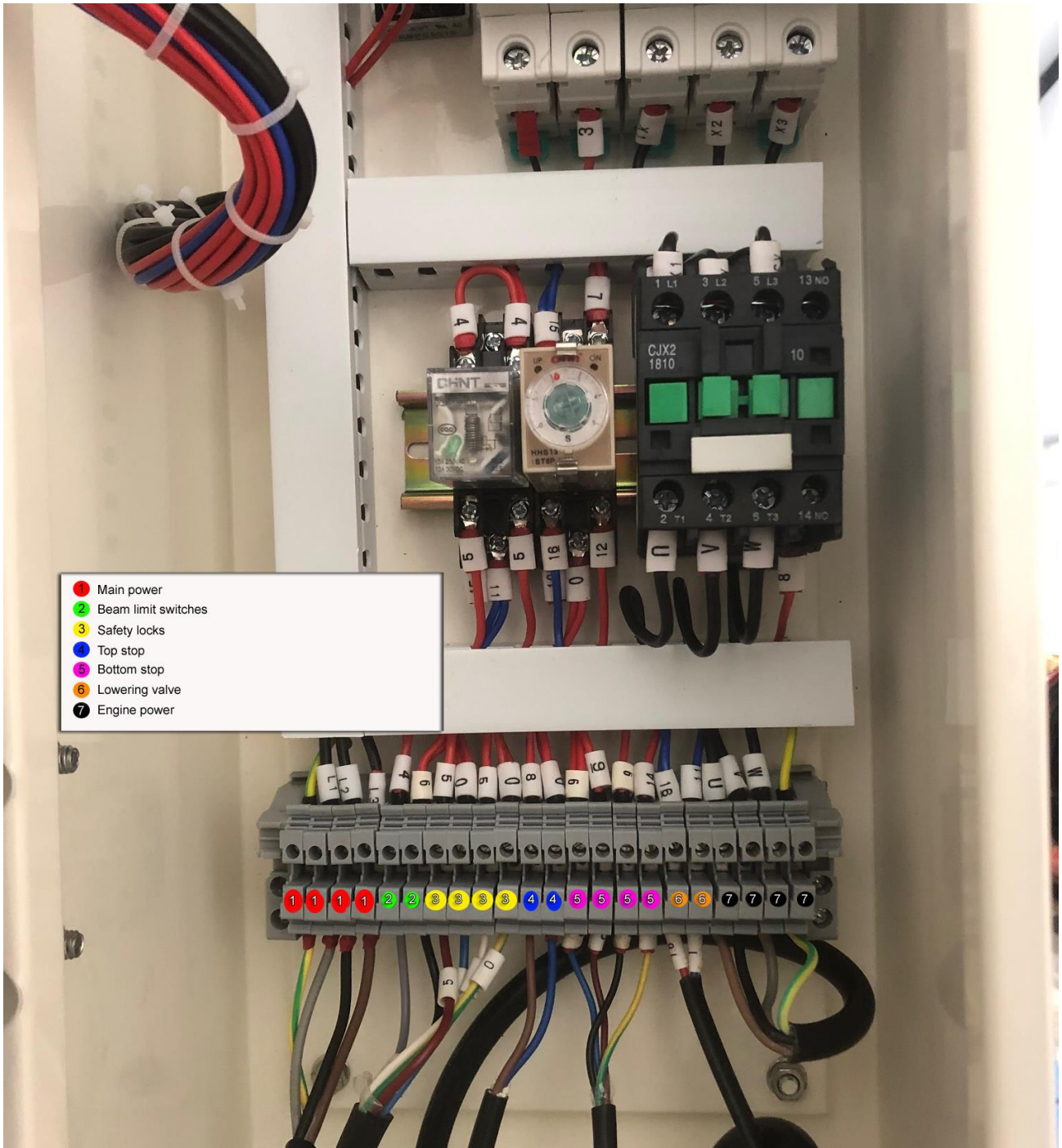

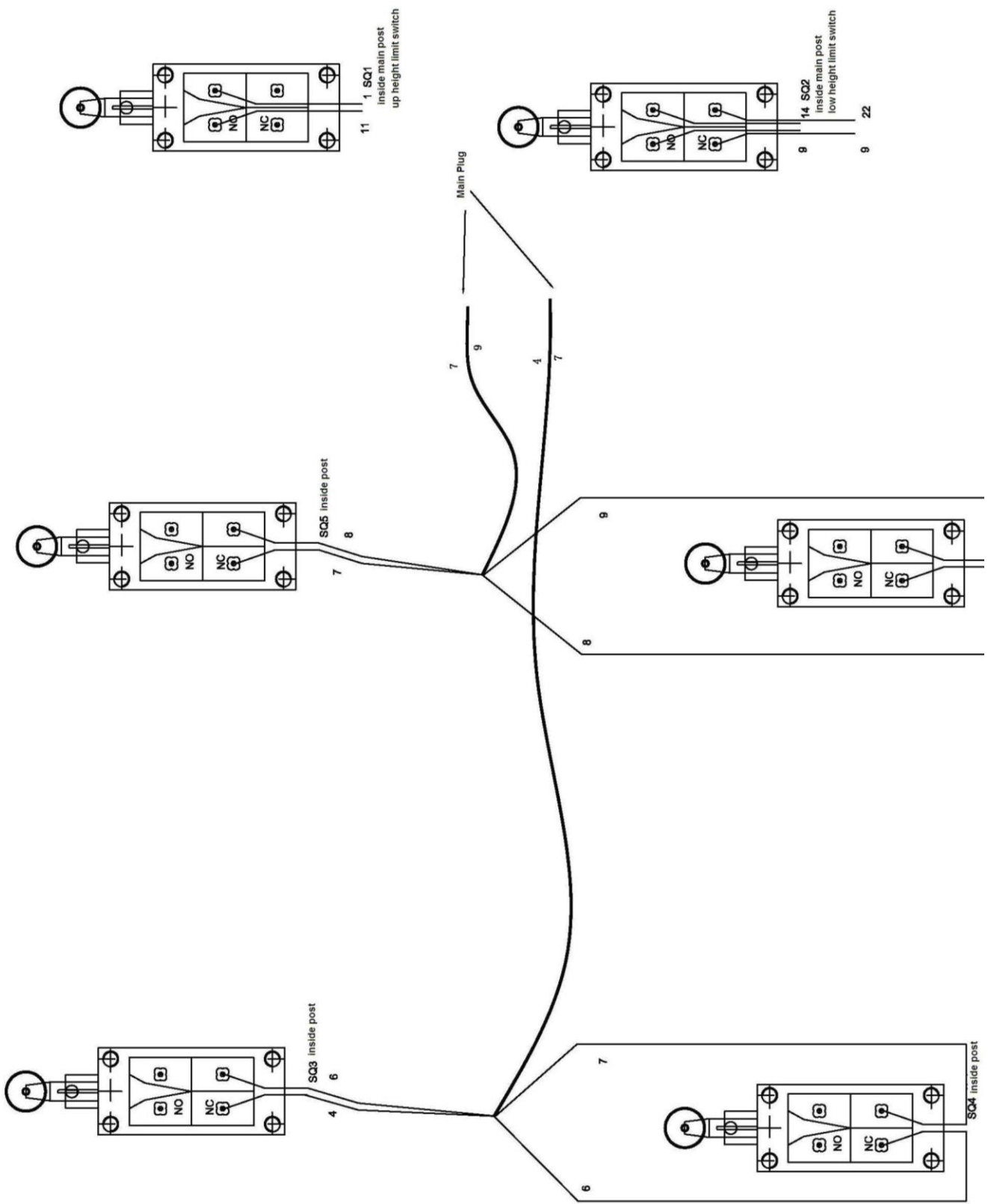



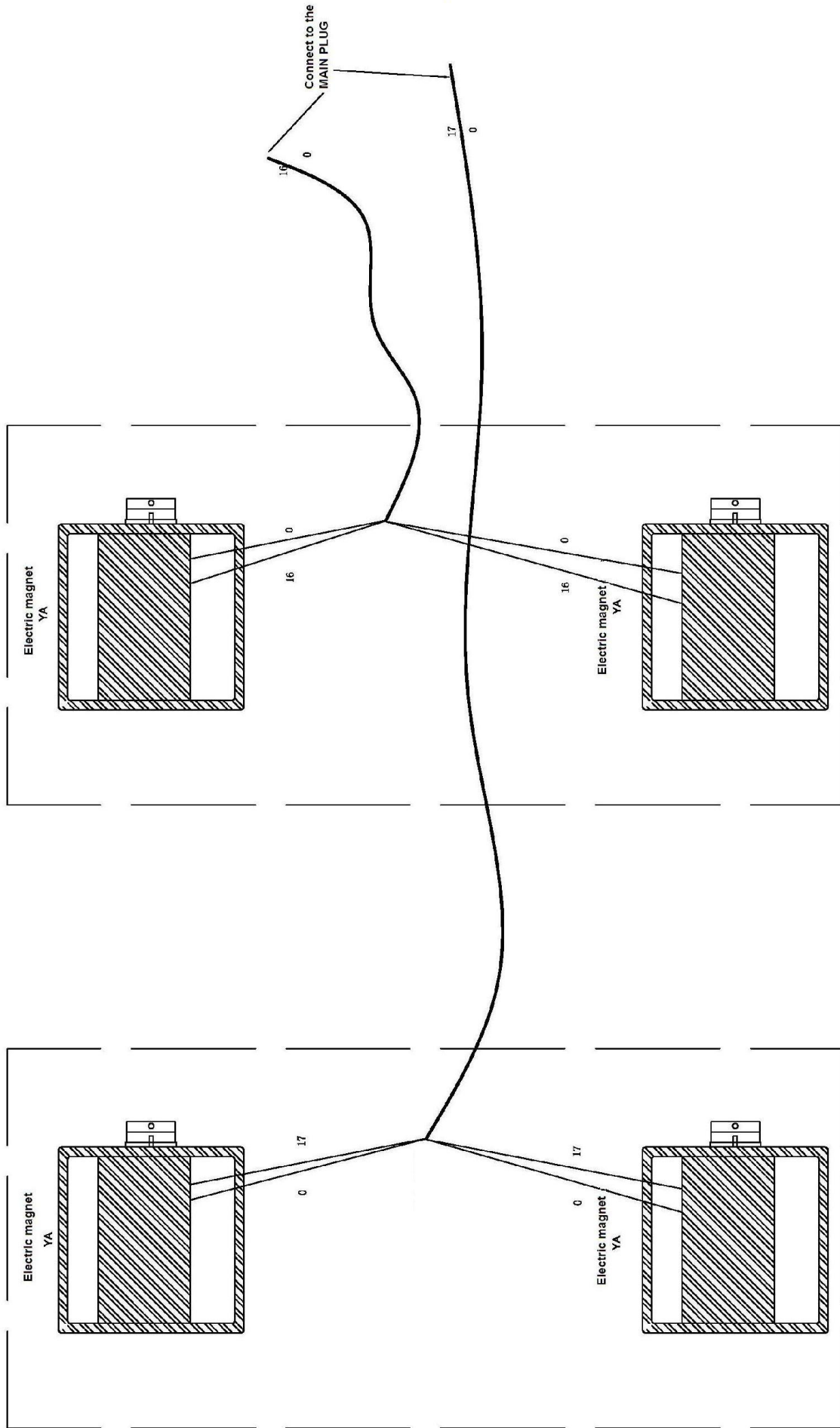

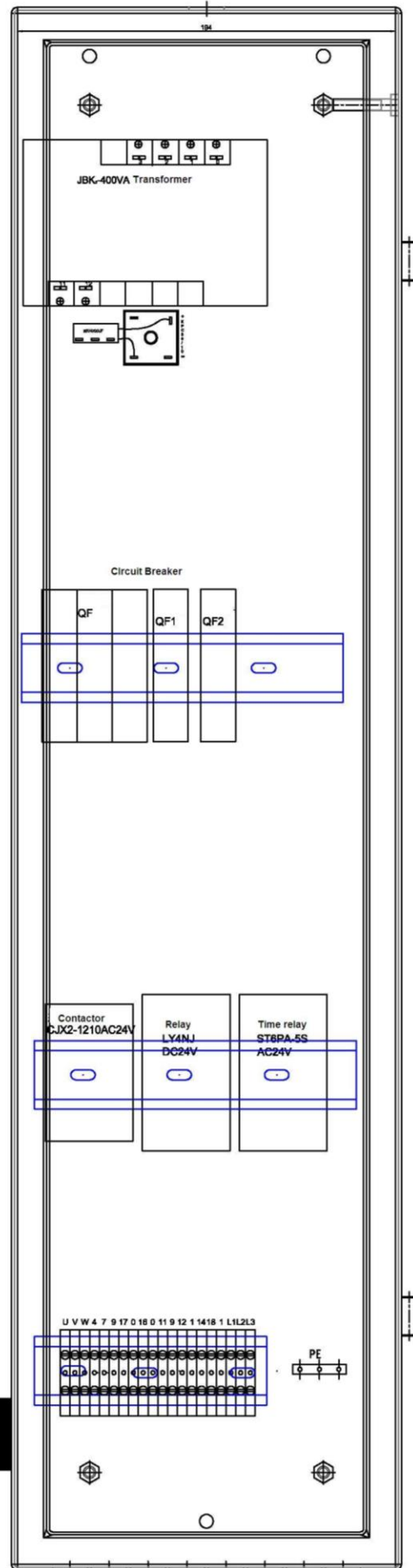
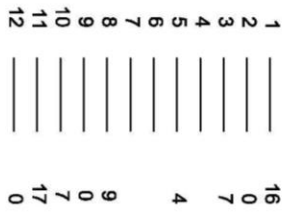
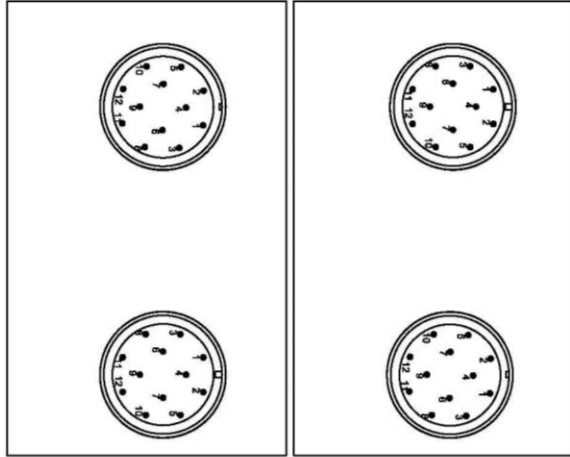

**Annex7: Separate diagrams for the lift JA5500F**

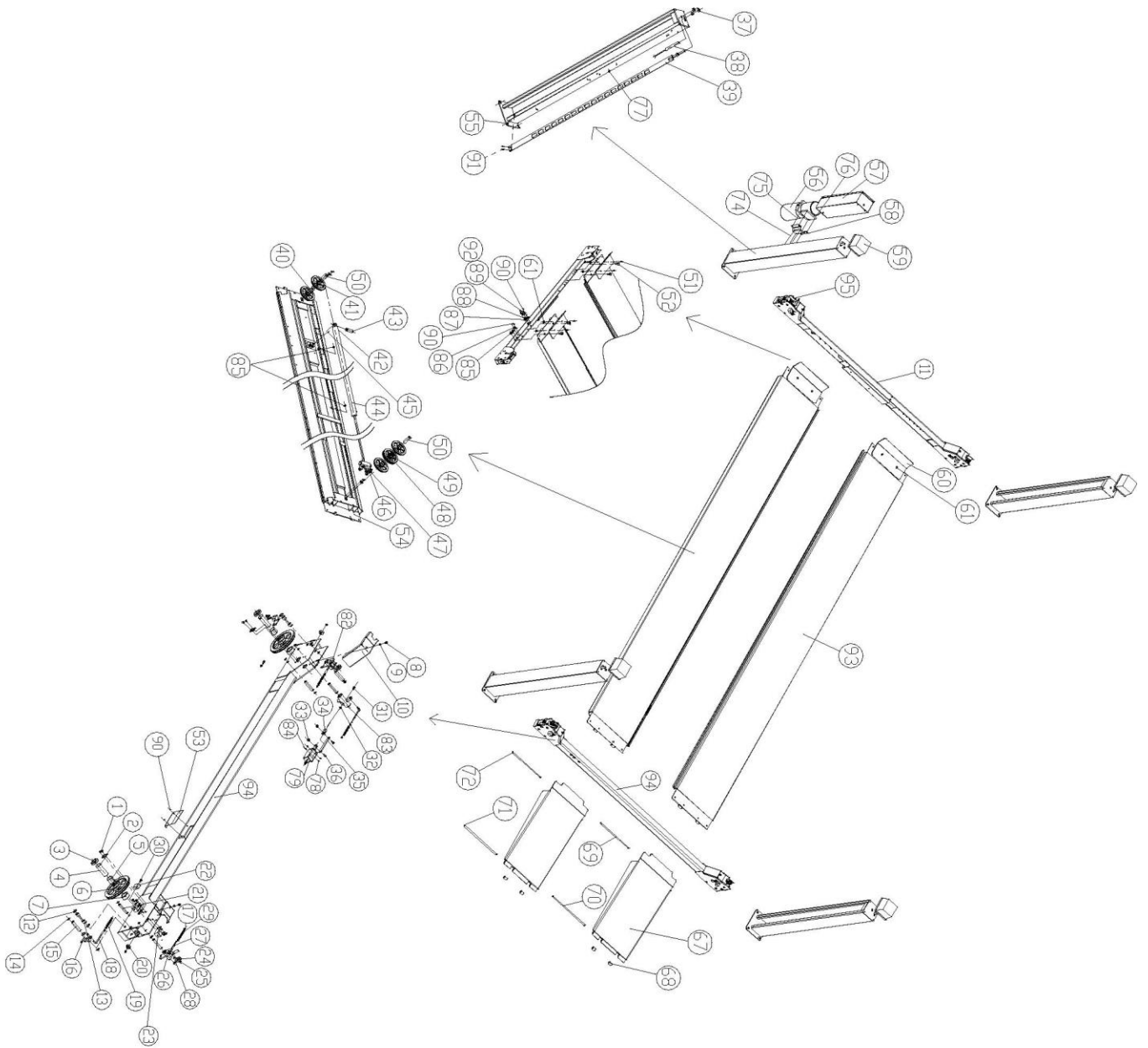

S/N	Material#	Name	Spec. (Drawing#)	Qty	Note
1	214002	Cross flat headed bolt	M8×12	16	
2	261042	Baffle block of shaft	JA5500FN-A3-B13	6	
3	262007	Spacer A	JA5500FN-A3-B1	4	
4	261024	Shaft A of the sheave	JA5500FN-A3-B4	4	
5	220013	Bushing	4040	4	
6	261004	Sheave A	JA5500FN-A3-B3	4	
7	262008	Spacer B	JA5500FN-A3-B2	4	
8	212046	Outside hex bolt	M8×15	20	
9	217002	Washer	M8	36	
10	262020	Protection cover	JA5500FN-A2-B5	4	
11	628002	Beam A (welding)	JA5500FN-A2-B1	1	
12	219002	Circlip	∅ 25	8	
13	261020	2	JA5500FN-A3-B11	4	
14	219006	Circlip	∅ 20	18	
15	261019	Shaft 1	JA5500FN-A3-B10	8	
16	261055	Safety block B2	JA5500FN-A3-B17	2	
17	216014	Self - lock button	M8	16	
18	261060	Adjustable rod A	JA5500FN-A3-B8	4	
19	261029	Spring	JA5500FN-A3-B32	4	
20	262005	Sliding block (side)	JA5500FN-A2-B4	4	
21	261021	Shaft 3	JA5500FN-A3-B12	4	
22	262004	Slider	JA5500FN-A2-B3	8	
23	261082	Slider holder	JA5500FN-A2-B2	8	
24	261081	Small sheave	JA5500FN-A3-B5	4	
25	219010	Circlip	∅ 16	12	
26	261101	Safety block A2	JA5500FN-A3-B16	2	
27	261100	Adjustable rod B	JA5500FN-A3-B9	4	
28	214004	Cross flat headed bolt	M6×16	4	
29	261006	Spring	JA5500FN-A3-B22	4	
30	214003	Cross flat headed bolt	M8×25	8	
31	212011	Outside hex bolt	M6×30	4	
32	216003	Nut	M6	7	
33	216019	Self - lock nut	M6	8	
34	261132	Adjustable column	JA5500FN-A3-B33	4	
35	261133	Adjustable chip	JA5500FN-A3-B34	2	
36	211008	Inside hex bolt	M6×25	8	
37	216009	Nut	M20	8	
38	261048	Safety rod (welding)	JA5500FN-A1-B2	4	
39	261103	Steel cable L=14360	JA5500F-14360	2	
40	220011	Bushing	4025	4	
41	261005	Sheave B	JA5500FN-A3-B15	4	
42	221030	Triangular oil hose tie-in	KLL8-02	1	
43	261401	4T-shaft of oil cylinder	JA5500FN-A26	1	
44	261015	4T-oil cylinder	JA5500FN-A3-B19	1	
45	211065	Inside hex stop screw	M6×10	1	

S/N	Material#	Name	Spec. (Drawing#)	Qty	Note
46	628402	4T-connction block of steel cable	JA5500FN-A3-B20	1	
47	261080	Steel cable clipper	∅ 10 steel cable	4	
48	261003	Rotor wheel C	JA5500FN-A3-B26	1	
49	220012	Bushing	4030	1	
50	261023	Shaft B of rotor wheel	JA5500FN-A3-B18	1	
51	212012	Outside hex bolt	M12x30	4	
52	211058	inside hex sunken head bolt	M12x25	8	
53	428165	Protection	JA5500FN-A3-B36	2	
54		Platform A	JA5500FN-A4	1	
	628029				
	222003	Expansion bolt		16	
		Hydraulic pump	M16x120	1	
		Control box	JA5500FN-A13	1	
	428070	Mounting plate of hydraulic pump	JA5500FN-A11	1	
	261092	Main post	JA5500FN-A10	4	
	428068	Guiding plate B	M12	2	
	216006	Nut	JA5500FN-A18	4	
	261501			2	
56	261077	Pin	JA5500FN-A22	4	
60	262011	Ball disk holder	JA5500FN-A20	6	
61	628008	Guiding plate (welding)	JA5500FN-A8-B1	2	
62	252025	Small rotor wheel	MR30-A22-B5	4	
63	428065	Shaft	JA5500FN-A8-B2	2	
	261069	Shaft of guiding wheel	JA5500FN-A8-B3	2	
	219019	Circlip	∅ 15	4	
65	224065	Open pin	∅ 3x40	4	
67	216005	Nut	M10	4	
68	242021	Hose fixing ring (∅ 20)	JA5500FE-A22	1	
69	215022	Cross round headed bolt	M4x14	8	
70	261605	Electric magnet	JA5500FN-A14	4	
71	214014	Cross flat headed bolt	M10x25	6	
72	216030	Self-lock nut	M10	6	
73	261054	Safety block B1	JA5500FN-A3-B7	2	
74	261102	Safety block A1	JA5500FN-A3-B6	2	
75	216027	Self lock nut	M4	8	
76	242022	Hose fixing ring (∅ 40)	JA5500FE-A21	4	
78	230022	Single hose fixer	28	1	
79	428163	Padding plate	JJA5500FN-A3-B35	2	
81	215026	Cross round headed bolt	M3x8	4	
83	334031	Main plug	P32K3A	2	

S/N	Material#	Name	Spec. (Drawing#)	Qty	Note
85	215032	Cross round headed bolt	M5×12	6	
				8	
				2	
	628317		JA5500FN-A5	1	

## Annex8: Spare parts list

### Spare parts for the electrical system





S/N	Material#	Name	Spec.	Unit	Qty	Picture
1	321001	Power switch	LW26GS-20/04	Pcs	1	
2	322008	Button	Y090-11BN	Pcs	2	
3	322003	Button	Y090-20BN	Pcs	1	
4	324021	Power indicator	AD17-22G-AC24 green	Pcs	1	
5	320088	Transformer	JBK3-400VA 220V-24V	Pcs	1	
6	320115	Transformer	JBK3 400VA 230V-24V	Pcs	1	Same outlook as item 5
7	320116	Transformer	JBK3 400VA 240V-24V	Pcs	1	Same outlook as item 5
8	320087	Transformer	JBK3-400VA 380V-24V	Pcs	1	Same outlook as item 5
9	320099	Transformer	JBK3-400VA 400V-24V	Pcs	1	Same outlook as item 5
10	320117	Transformer	JBK3 400VA 415V-24V	Pcs	1	Same outlook as item 5
11	330004	Contactor	CJX2-1210/AC24	Pcs	1	
12	327002	Circuit breaker	DZ47-63C32/2P	Pcs	1	
13	327004	Circuit breaker	DZ47-63 C16 /3P	Pcs	1	

S/N	Material#	Name	Spec.	Unit	Qty	Picture
14	327010	Circuit breaker	DZ47-63C6/1P	Pcs	1	
15	327020	Circuit breaker	DZ47-63C16/1P	Pcs	1	Same outlook as item 14
16	261605	Electric magnet	6435N-A14 (MQB3-10-20/AC24V)	Pcs	4	
17	322010	Emergency stop	Y090-11ZS/red	Pcs	1	
18	324022	Alarm buzzer	AD17-22SM/DC24	Pcs	1	
19	336012	Bridge rectifier	KBPC5A-35A	Pcs	1	
20	335007	Capacitor	4700UF/50V	Pcs	1	
21	328017	Control box	6435N-A19	Pcs	1	
22	326017	Relay	LY4NJ/DC24V	Pcs	1	
23	326016	Relay holder	PTF-14A-E	Pcs	1	
24	326005	Time relay	ST6P-2AC24V 5S	Pcs	1	
25	326006	Holder of time relay	PYF-08A-E	Pcs	1	



S/N	Material#	Name	Spec.	Unit	Qty	Picture
26	334031	Main plug	P32K3A	Pcs	1	
27	334032	Main plug	P32J3R	Pcs	1	
28	334033	Main plug	P32J3A	Pcs	1	
29	334034	Main plug	P32K3R	Pcs	1	
30	321024	Limit switch	YBLX-ME8104	Pcs	6	

### Spare parts list for the hydraulic system

S/N	Material#	Name	Spec.	Unit	Qty	Picture
1	N/A	Hydraulic block	YF-2	Pcs	1	
2	313042	Electrical unloading valve	XYF-C	Pcs	1	
3	313018	Single-way valve	DYF-C	Pcs	1	
4	313020	Anti-surge valve	EYF-C	Pcs	1	
5	313021	Throttle valve		Pcs	1	

S/N	Material#	Name	Spec.	Unit	Qty	Picture
6	313017	Cushion valve	HCYF-C	Pcs	1	
7	211064	Sunken head inside hex fitting	M14*1.5	Pcs	2	
8	333022	Tie-in of the pump	M14*1.5-G1/4 inside swivel	Pcs	1	
9	313015	Coupling	YL-A	Pcs	1	
10	312106	Gear pump	CBK-F330	Pcs	1	
11	313030	Oil-absorbing pipe	YX-B/270	Pcs	1	
12	313014	Oil filter	YF-C	Pcs	1	
13	313013	Oil-back pipe	YH-D	Pcs	1	
14	329001	Oil tank	10L plastic tank	Pcs	1	

## Annex9: Size and weight requirements on vehicles

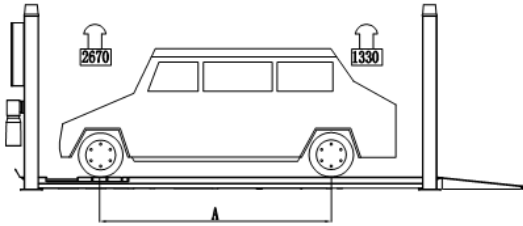
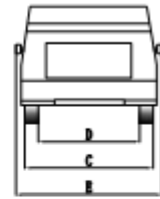
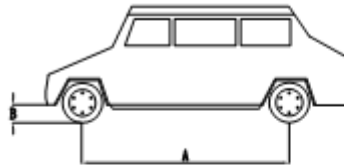
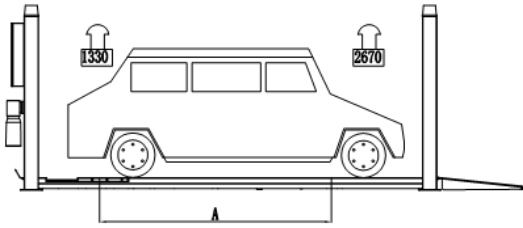

	Min (mm)	Max (mm)
A	-	3000
B	100	-
C	-	2000
D	1000	-
E	-	2400

## EC Declaration of Conformity (informative)

In accordance with EN ISO 17050-1:2010

We (name of applicant)           Jema Autolifte A/S  
of (address of applicant)        Industrihegnet 2, 4030 Tune, Denmark  
hereby declare that the equipment submitted for Type Approval is in conformity with the requirements of following EU Directives:

2006/42/EC                    The Machinery Directive

We hereby declare that:

Equipment                    Four Post Lift  
Model number                JA5500F  
Serial Number                202109003

is in conformity with the applicable requirements of the following documents

Ref. No.	Title	Edition/date
2006/42/EC	Essential health and safety requirements relating to the design and construction of machinery	Annex I
EN 60204-1	Safety of machinery - Electrical equipment of machines – Part 1: General requirements	2018
EN 1493	Vehicle lifts	2010

The machine has been the subject of a type examination by CTI-CEM International Ltd (Notified Body Number 2845) & granted Type Examination Certificate number: C-353-20-1129-21-01-B3

I hereby declare that the equipment named above has been designed to comply with the relevant sections of the above referenced specifications and is in accordance with the requirements of the following Directive(s):

Signed by: .....

Full Name:                    Kasper  
Title:                         Director  
Location:                    Tune, Denmark  
Date:                         22, Nov. 2022



Document ref. No.  
C-353-20-1129-21-01-B3

The technical documentation only for the machinery certified to the Test Standards as required by the Machinery Directive, is available from:

Name:                         CTI-CEM International Ltd  
Address:                    Unit 200 Greenogue Business Park, Grants Lane, Rathcoole, Co. Dublin, Ireland