

WE ARE HERE TO SURPRISE!



JA4200T-CF

Lifting capacity: 4200KG

2 Post Lift

Electrical Release

Original Instruction



Read this entire manual carefully and completely before installation or operation of the lift.



INDEX

1. Important safety instructions	3~6
1.1 Important notices	
1.2 Qualified personnel	
1.3 Danger notices	
1.4 Condition notices	
1.5 Warning signs	
1.6 Level of sound pressure	
1.7 Training	
2. Overview of the machine	6~7
2.1 Product introduction	
2.2 Technical data	
2.3 Construction of the lift	
3. Installation instruction	7~13
3.1 Preparation before installation	
3.1.1 Tool and equipments needed	
3.1.2 Parts check	
3.1.3 Floor specifications	
3.2 Precautions during installation	
3.3 Installation	
3.4 Check list after installation	
4. Operation instruction	14~21
4.1 Precautions during operation	
4.2 control box panel description	
4.3 Flow chart for operation	
4.4 Operation	
4.5 Emergency lowering when the power is off	
5. Trouble shooting	21~22
6. Maintenance	22~23
7. Annex	23~31
Annex1. Shipping sheet	
Annex2. Overall diagram	
Annex3. Space required	
Annex4. Hydraulic connection	
Annex5. Control box overview	
Annex6. Wiring diagram	
Annex7. Exploded drawing parts	
Annex8. Spare parts list	
Annex9. Size and weight requirement for the vehicle & valve board diagram	
Annex10. CE Certificate	

1. Important safety instructions

1.1 Important notices

Jema Autolifte will give the user one-year warranty of quality for the lift. If something is wrong with the lift, Jema Autolifte or the distributor will provide the spare part for it to be replaced. Jema Autolifte will not take any responsibility for improper installation, wrong operation, overload of the max. Lifting capacity, wrong concrete ground (that can not meet the requirements in the manual), normal mechanical abrasion and insufficient maintenance. The warranty will be carried out on the basis of the type and serial number of the equipment. When contacting Jema Autolifte or the distributor the users shall provide picture documentation if asked.

The 2-post lift is suitable for lifting motor vehicles having maximum weight as described, any other use is to be considered improper and irrational and thus highly forbidden. Jema Autolifte cannot be held responsibilities for any damage or injuries caused by an improper use or by the non-observance of the following instructions.

Read this guide carefully before using the lift and follow the instructions given by this guide to grant the lift a correct function, efficiency and a long service life.

1.2 Qualified personnel

1.2.1 The lift may only be used by qualified staff, properly trained for the specific use of the lift.

1.2.2 The wiring must comply with local code and a certified electrician for electrical hook up.

1.2.3 Only authorized personnel are allowed in lifting area.

1.3 Danger notices

1.3.1 Do not install the lift on any asphalt surface.

1.3.2 Read and understand all safety warning procedures before operating the lift.

1.3.3 The lift, in its standard version, is not designed for outdoor use.

1.3.4 Keep hands and feet away from any moving parts. Keep feet clear of lift when lowering.

1.3.5 The lift may only be used by qualified staff, properly trained for the specific use of the machine.

1.3.6 Do not wear unfit clothes such as large clothes with flounces, tires, etc, which could get caught by moving parts of the machine.

1.3.7 The lift surrounding area must be free from people or objects which could be a danger for lifting operations.

1.3.8 The lift is only designed to lift the entire body of vehicle, having maximum weight not more than the lift capacity.

1.3.9 Always insure the safety devices are engaged before any attempt to work on or near vehicle.

1.3.10 The vehicle must be centered and positioned in a stable correct way and following the instructions given by Jema Autolifte.

1.3.11 Make sure that the lift and its devices are working correctly, according to the specific instructions for maintenance

1.3.12 Lower the lift to its lowest position when finished.

1.3.13 Do not modify the lift without Jema Autolifte's advice.

1.3.14 If the lift is not to be used any more, owners is suggested to removing the power supply connections, emptying the oil tank and disposing the liquids by right way.

1.3.15 If the lift is to be left unused for a long period, proceed as follows:

a. Disconnect the energy source.

b. Empty the oil tank.

c. Grease the moving parts which might be damaged by dust or drying out.

1.4 Condition notices

Generally, this lift will be installed on the following conditions:

- 1.4.1 220 Volt ~ 240 Volt, 380 Volt ~ 415 Volt, Supply voltage: 0.9 - 1.1 nominal supply voltage
- 1.4.2 Source frequency: 0.99 - 1.01 nominal frequency
- 1.4.3 Ambient temperature: 5? - 40?
- 1.4.4 Altitude: shall be at altitudes up to 1000m above mean sea level
- 1.4.5 Relative humidity: not exceed 50% at 40?
- 1.4.6 Atmosphere: Free from excessive dust, acid fume, corrosive gases and salt.
- 1.4.7 Avoid exposing to direct sunlight or heat rays which can change the environmental temp.
- 1.4.8 Avoid exposing to abnormal vibration.
- 1.4.9 Electrical equipment shall withstand the effects of transportation and storage temperature within a range of -25? to 55? or short periods not exceeding 24 hours at up to +70*





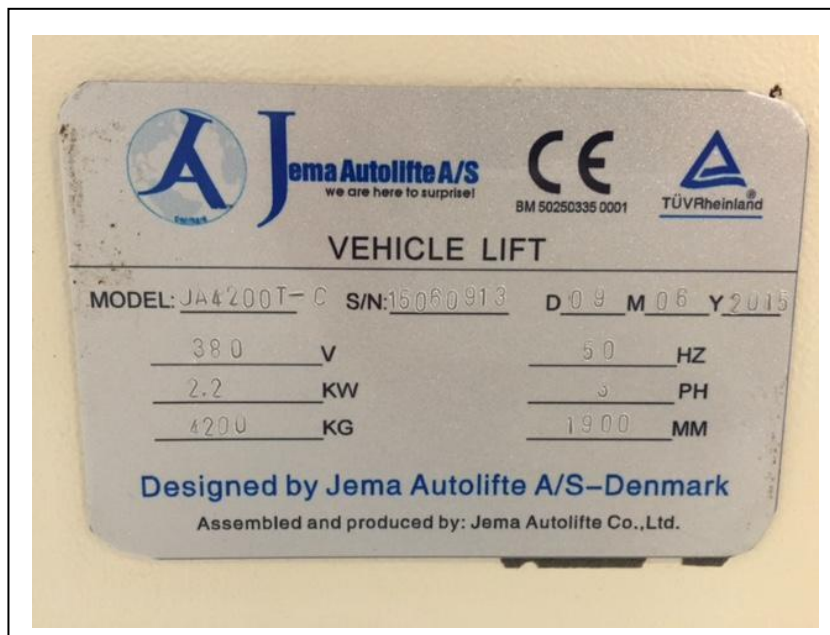





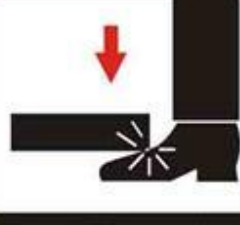

Attention: Dispose the unused oil by a correct way to protect the surround environment.

CE PLATE:



1.5 Warning signs

All safety warning signs presented on the lift with the purpose to draw the operator's attention from dangerous or unsafe situations. The labels must be kept clean, and they have to be replaced if detached or damaged. Read the meaning of the labels.

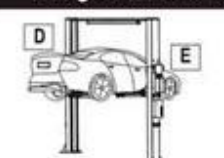
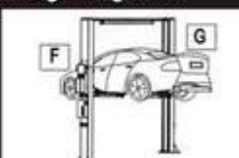
 <p>Remain clear of lift when lowering or lifting vehicle.</p>	 <p>Clear area if vehicle is in danger of falling.</p>	<p>CAUTION</p>  <p>Lift vehicle at the manufacturer's points</p>	<p>CAUTION</p>  <p>Always use safety stands when removing/ installing heavy components</p>																																										
 <p>Locate the vehicle with center gravity right between two adapters.</p>	 <p>Keep feet away from adapter while lift lowering.</p>	<p>CAUTION</p>  <p>Use height extension when necessary to ensure good contact.</p>	<p>CAUTION</p>  <p>Auxiliary adapters may reduce load capacity.</p>																																										
 <p>Do not override self-closing lift controls</p>	 <p>Do not shake vehicle heavily while on lift.</p>	 <p>Read the manual before installation or operation of the lift</p>	<p>WARNING</p> <ol style="list-style-type: none"> 1. Travelling on the load carrying devices is forbidden. 2. After raising a short distance, checked to ensure that it is correctly and safely positioned. 3. It is forbidden to climb onto the load or load carrying devices when they are raised. 																																										
<p>CAUTION</p>  <p>Lift is only allowed to be used by trained operator.</p>	<p>CAUTION</p>  <p>Only authorized personnel allowed in lift area</p>	<p>Arms must support the rated load weight as the following diagram.</p> <div style="display: flex; justify-content: space-around;"> <div data-bbox="805 1747 1053 1926">  <table border="1" data-bbox="805 1937 1053 2089"> <thead> <tr> <th>Lifting capacity</th> <th colspan="2">Load distribution</th> </tr> <tr> <th></th> <th>D</th> <th>E</th> </tr> </thead> <tbody> <tr> <td>3.2T</td> <td>1.4±0.1T</td> <td>1.8±0.1T</td> </tr> <tr> <td>3.8T</td> <td>1.7±0.1T</td> <td>2.1±0.1T</td> </tr> <tr> <td>4.0T</td> <td>1.8±0.1T</td> <td>2.2±0.1T</td> </tr> <tr> <td>4.5T</td> <td>2.1±0.1T</td> <td>2.4±0.1T</td> </tr> <tr> <td>5.0T</td> <td>2.3±0.1T</td> <td>2.7±0.1T</td> </tr> </tbody> </table> </div> <div data-bbox="1069 1747 1324 1926">  <table border="1" data-bbox="1069 1937 1324 2089"> <thead> <tr> <th>Lifting capacity</th> <th colspan="2">Load distribution</th> </tr> <tr> <th></th> <th>F</th> <th>G</th> </tr> </thead> <tbody> <tr> <td>3.2T</td> <td>1.8±0.1T</td> <td>1.4±0.1T</td> </tr> <tr> <td>3.8T</td> <td>2.1±0.1T</td> <td>1.7±0.1T</td> </tr> <tr> <td>4.0T</td> <td>2.2±0.1T</td> <td>1.8±0.1T</td> </tr> <tr> <td>4.5T</td> <td>2.4±0.1T</td> <td>2.1±0.1T</td> </tr> <tr> <td>5.0T</td> <td>2.7±0.1T</td> <td>2.3±0.1T</td> </tr> </tbody> </table> </div> </div>		Lifting capacity	Load distribution			D	E	3.2T	1.4±0.1T	1.8±0.1T	3.8T	1.7±0.1T	2.1±0.1T	4.0T	1.8±0.1T	2.2±0.1T	4.5T	2.1±0.1T	2.4±0.1T	5.0T	2.3±0.1T	2.7±0.1T	Lifting capacity	Load distribution			F	G	3.2T	1.8±0.1T	1.4±0.1T	3.8T	2.1±0.1T	1.7±0.1T	4.0T	2.2±0.1T	1.8±0.1T	4.5T	2.4±0.1T	2.1±0.1T	5.0T	2.7±0.1T	2.3±0.1T
Lifting capacity	Load distribution																																												
	D	E																																											
3.2T	1.4±0.1T	1.8±0.1T																																											
3.8T	1.7±0.1T	2.1±0.1T																																											
4.0T	1.8±0.1T	2.2±0.1T																																											
4.5T	2.1±0.1T	2.4±0.1T																																											
5.0T	2.3±0.1T	2.7±0.1T																																											
Lifting capacity	Load distribution																																												
	F	G																																											
3.2T	1.8±0.1T	1.4±0.1T																																											
3.8T	2.1±0.1T	1.7±0.1T																																											
4.0T	2.2±0.1T	1.8±0.1T																																											
4.5T	2.4±0.1T	2.1±0.1T																																											
5.0T	2.7±0.1T	2.3±0.1T																																											

1.6 Level of sound pressure

The sound pressure of the lift does not exceed 65DB. For the sake of your healthy, we suggest you place a noise meter in the operation area.

1.7 Training

Only qualified personnel can operate and use the lift. Contact Jema Autolifte or the distributor to provide with trained courses and aid you in becoming familiar with the lift.

2. Overview of the machine

2.1 Product Introduction

The floor plate lift is composed of posts, carriages, lifting arms, hydraulic cylinders, power unit and floor plate, etc. The lift is operated by an electric motor controlling a hydraulic system, which delivers the hydraulic fluid to cylinders inside the columns for lifting two carriages. The safety teeth block will bite with safety plate in the posts automatically. Therefore, the lift will not lower when hydraulic system trouble happens.

Safety structure:

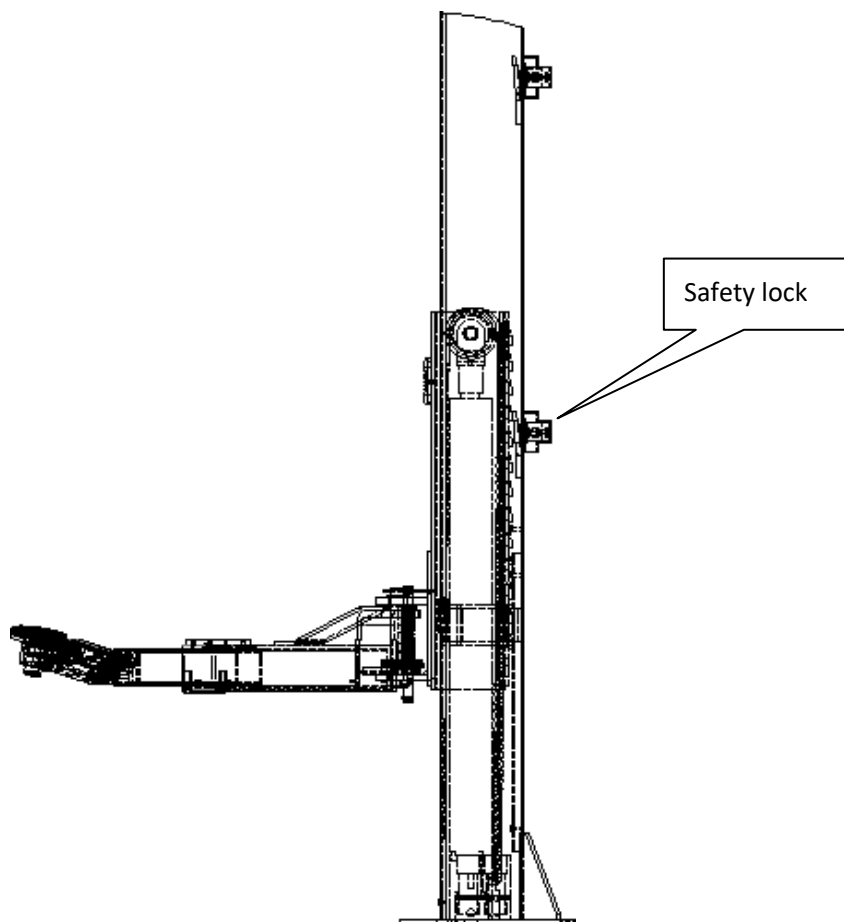

2.2 Technical data

Model	Lifting capacity	Lifting time	Lifting height	Height	Width	Width between posts	Voltage	Max pressure	Gross weight
JA4200T-CF	4200kg	50 Sec	1918mm	3924mm	3583mm	2820mm	380v	26MPa	750kg

2.3 Construction of the lift

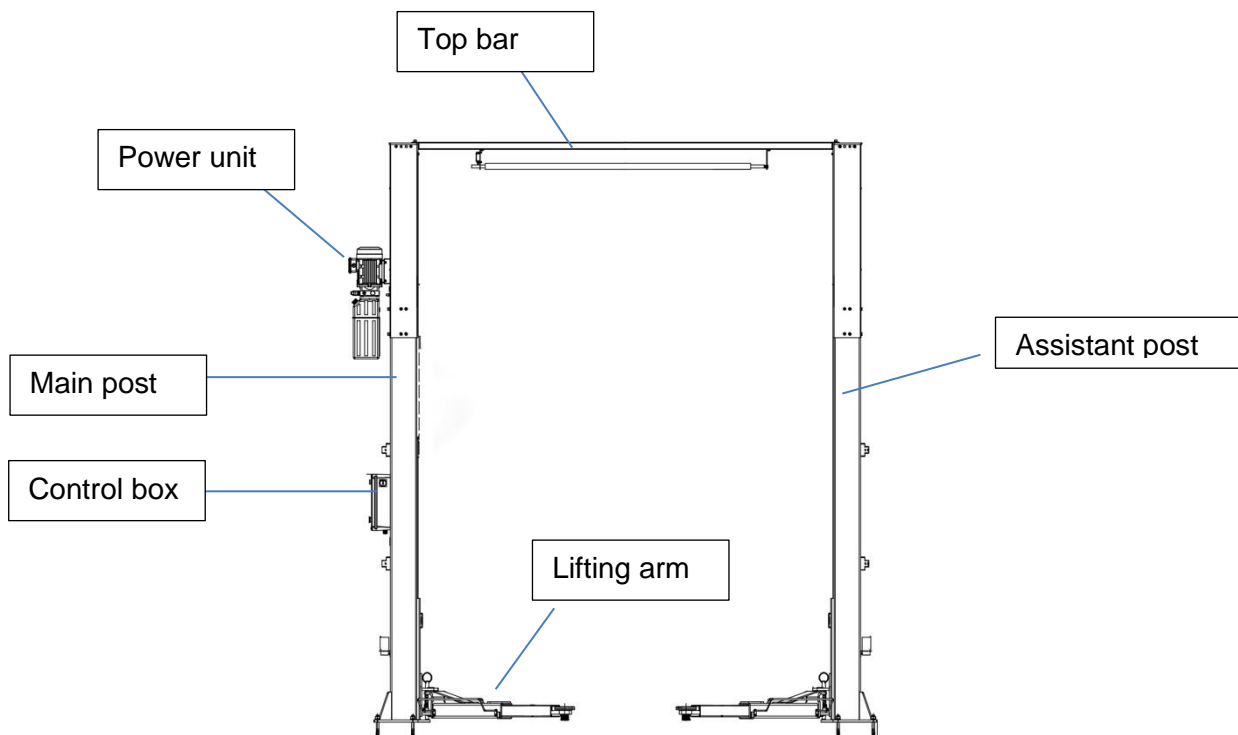

3. Installation instruction

3.1 Preparation before installation

3.1.1 Tools and equipment's needed

- ✓ Appropriate lifting equipment
- ✓ AW 32. 46 or other good quality garage hydraulic oil.
- ✓ Rotary Hammer Drill with 3/4" drill bit.
- ✓ Chalk line and tape measure.
- ✓ Sockets and Open wrench set.
- ✓ Hammer 4pounds
- ✓ $\Phi 2$ tape measure

3.1.2 Parts check --- Annex 1 (shipping sheet)

Remove the packaging and check that all parts for the lift are in the package per. Annex 1. Please contact Jema Autolifte or the distributor where the purchase is undertaken if any parts are missing. If you do not contact Jema Autolifte or the distributor within 2 weeks of receipt, and missing parts are noticed when installing the lift, will Jema Autolifte as well as our distributors are not responsible for missing parts and will charge for the purchase of spare parts.

3.1.3 Floor specifications

The lift should be fixed on a smooth and solid concrete ground with its strength more than 3000psi, tolerance of flatness less than 5mm and minimum thickness of 200mm. In addition, newly built concrete ground must undergo more than 28days' cure and reinforcement.

3.2 Precautions during installation

3.2.1 Make sure that the columns are vertical to the floor.

3.2.2 When installing the hydraulic oil hoses on both piston and engine please make sure they are installed properly to prevent oil leaks.

3.2.3 All bolts on the lift must be tightened when the lift is assembled as they may have shaken themselves loose during transport.

3.2.4 Placing no vehicle on the lift before it is tested after installation.

3.3 Installation



Step 1: Remove the packing of the lift and remove the cardboard box with accessories, and the top bar.

Step 2: Remove the lift arms and the control box located the columns.

Step 3: Support the columns and remove the bolts that hold the columns in each end of the transport cage.

NOTE: Be careful if the columns fall down will the lift or people around the lift be injury

Step 4: Rise the columns in vertical position with a lifting device lifting.

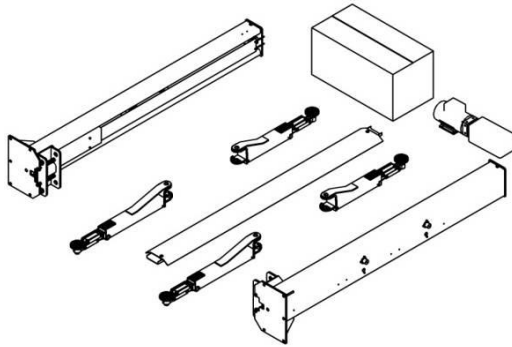

Step 5: Decide the installation position of the columns, erect the main and assistant post. Pay attention that the width between posts is 2820mm.

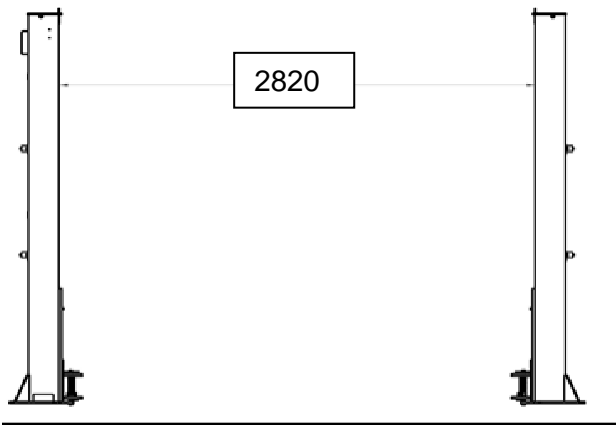

1. It must also be decided on which side the main column should be placed. (Normally left in the access direction is normal)
2. When the position is selected, use now lime ribbon to place the main column and the assisting column in line to each other.
3. Before work is continued, double check that the columns are the correct position in the room and the columns are properly placed to each other.

Step 6: Connect the extending post firmly secured on to the body posts.

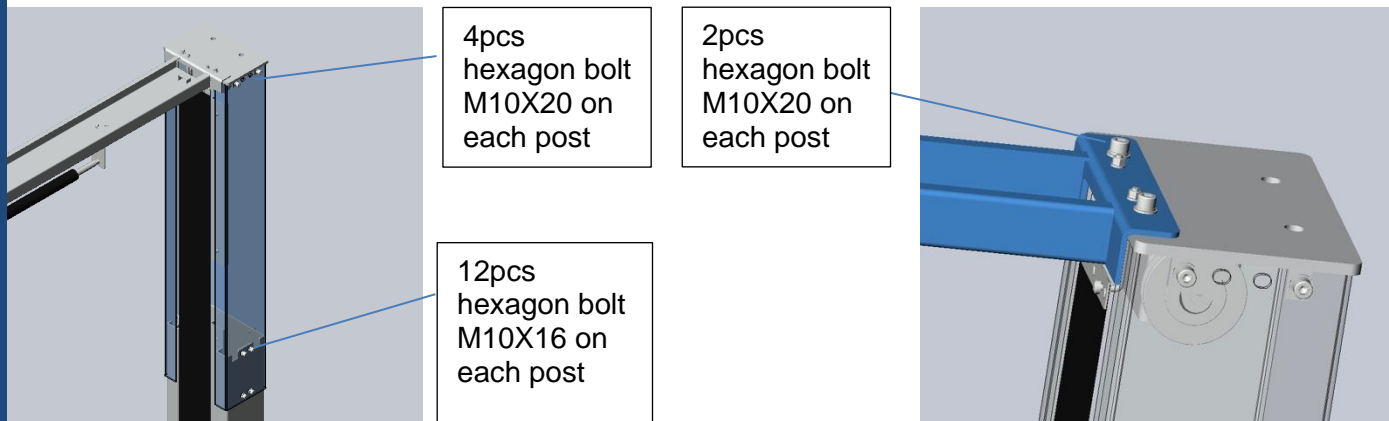

WE ARE HERE TO SURPRISE!

- 1、 Drill each anchor hole in the concrete using a rotary hammer drill. To assure full holding power, do not ream the hole or allow drill to wobble.
- 2、 After drilling, remove dust thoroughly from each hole and make certain that the column remains aligned with the chalk line during this process.
- 3、 Position the main column at the designated chalk locations and follow the same procedures step 1, 2 to position the assistant column.

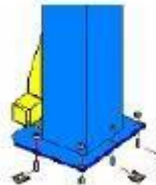
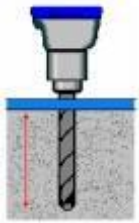

Step 7: Installation and adjustment of the calibration wire

1. Rise and lock each carriage approximately 800 mm bottom position.
2. Make sure the safety locks in each column are activated before mounting the calibration wires.
3. Both carriages for the main column and the Assistant column must be the same height when installing the calibration wires.
4. With the carriages at the same height from the floor, install the calibration wires as shown below.
5. After the calibration wires are installed, each wire adjusted to have a uniform stance.
(It is IMPORTANT the calibration wires are not too tight since that will give unexpected load on the wire wheel and bushings)
6. Lubricate the wire with Chain spray or grease.

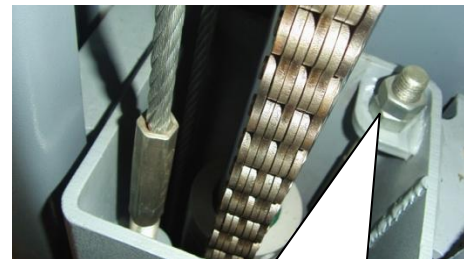
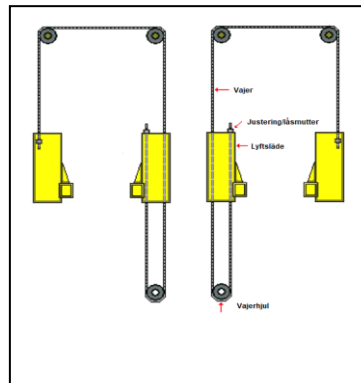
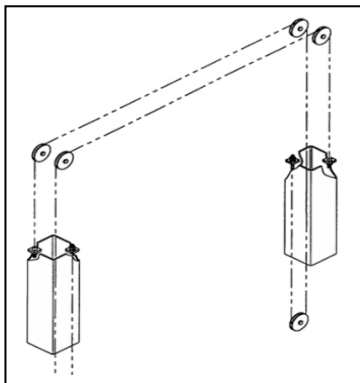

The bolt and nut to adjust the calibration wire

Step 8: Install the power unit on the main column.

1. Install the power unit with the 8mm bolts which is with the lift.
(The bolts should NOT be tightend before the hydraulic oil hoses and been installed)

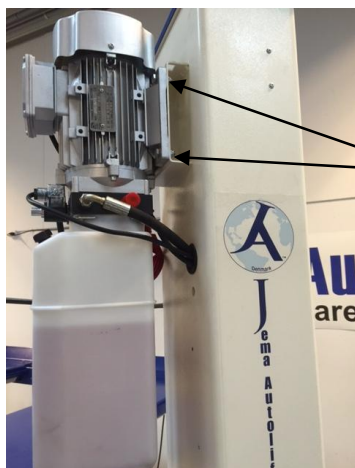

8mm bolte

WE ARE HERE TO SURPRISE!

Step 9: Install the hydraulic oil hoses on the main column.

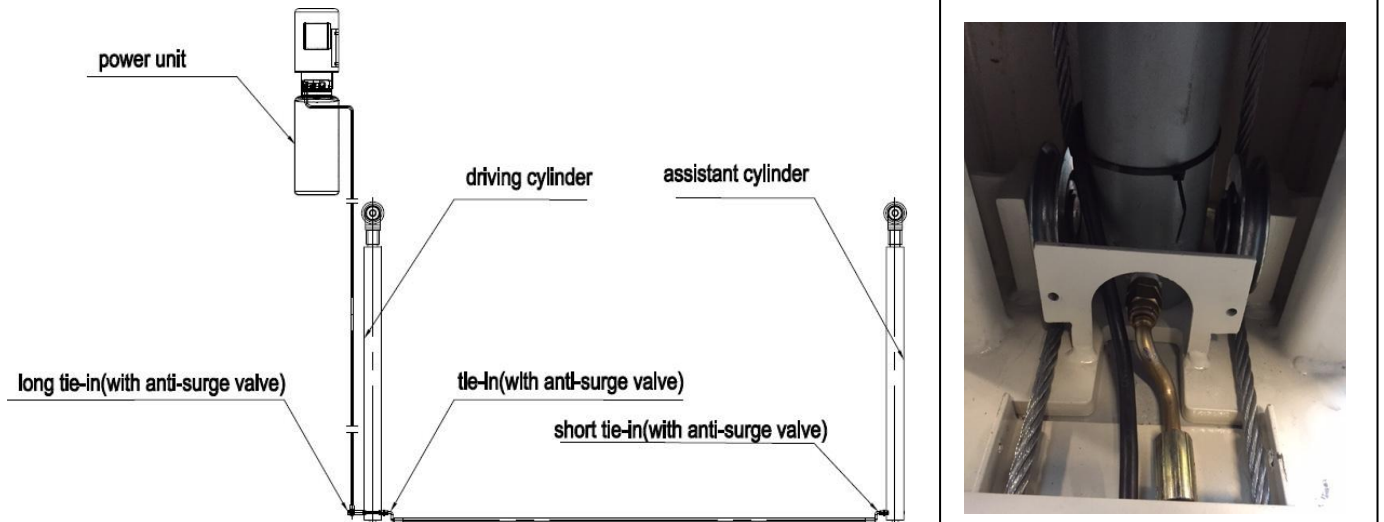

Step 10: Install four safety plates, four electromagnets and the electromagnet covers. Connect the wire to electromagnets.

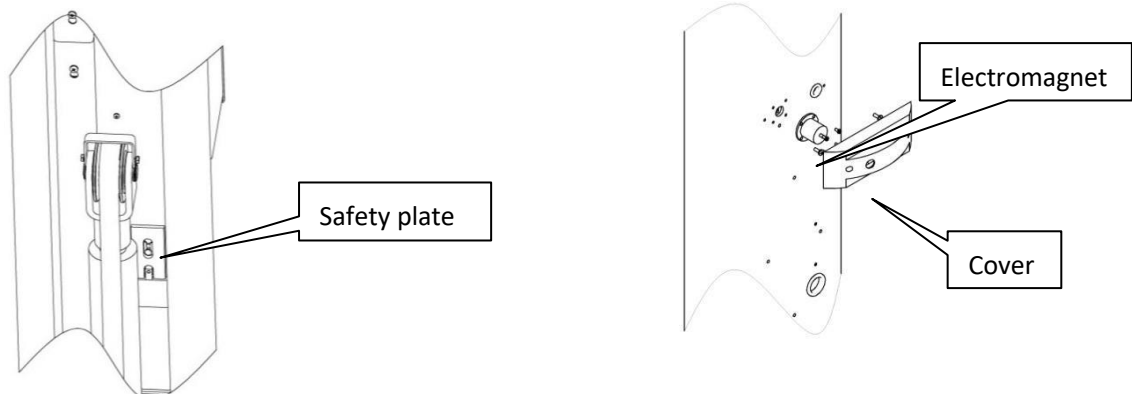

WE ARE HERE TO SURPRISE!

Step 11: Mount the control box (Remember to fasten all terminal blocks and wires as they may shake loose during transport)

1. Connect the power unit with the control box as the wiring diagram.

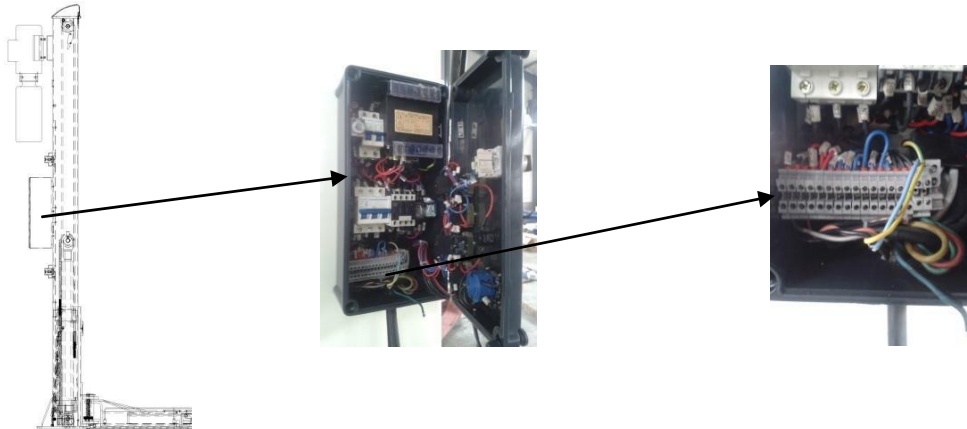

2. Connect the limit switch on the main Column. *(NB. Note the misalignment of the limited switch within the column!)*

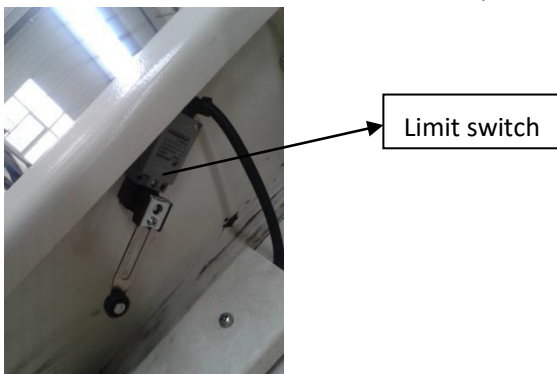

Step 12: Install the oil hose cover of both columns.

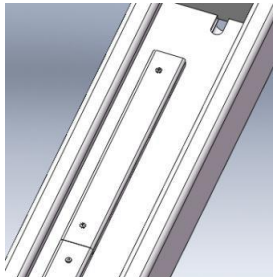

Step 13: Install the lifting arms.

Mount the lift arms with the supplied mandrels, it is important respect of the weight distribution on the lift that the long arms are ALWAYS placed at the rear of the vehicle and therefore will be mounted as shown on the picture below. Check and adjust the arm lock to go in the grip when the lift is raised so that the arms cannot move away under the vehicle when lifting.

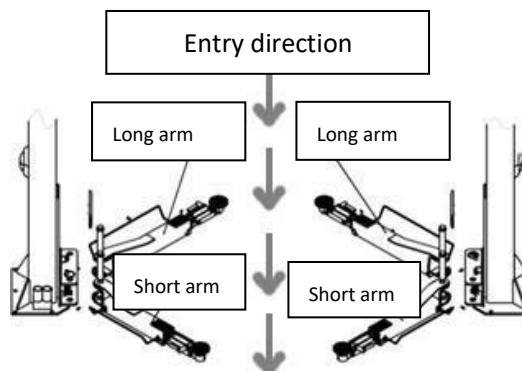

WE ARE HERE TO SURPRISE!

Step 14: Add the hydraulic oil.

The volume of the oil tank is 12L, to ensure the lift in a normal work condition, the oil should be over 90% of the oil tank volume; Use AW 32# in winter/46# in summer or other good quality garage hydraulic oil.



Step 15: When all the steps from 1 to 14 are double-checked, connect the lift to power and try to press the "UP" button (Do not place any vehicle in this step)

Step 16: Install the chain protection and the door-opening protection.

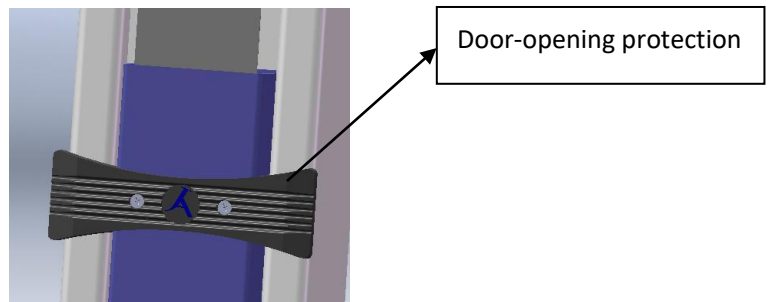
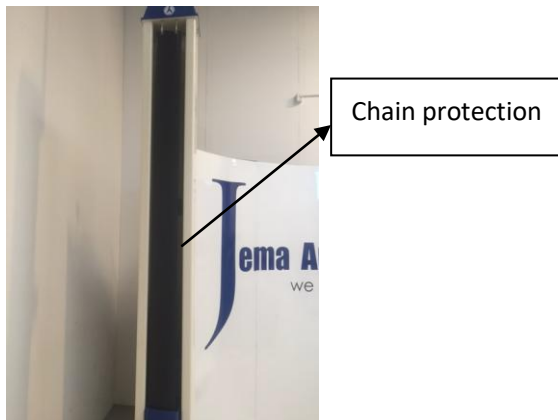

When everything has been installed and the lift is tested, then install the foot protection and high adaptors.



3.4 Check list after installation.

S/N	Check items	YES	NO
1	Are the columns placed 100% vertically?		
2	Are columns placed opposite each other?		
3	Are all hydraulic hoses tight?		
4	Are ALL cables in the control box tightened?		
5	Are ALL screws and bolts on the lift tightened?		
6	Are the arm locks properly adjusted so they go in grip when lifting?		
7	Are the lift safely and securely anchored in the floor?		

TIGHTENED EVERYTHING AGAIN WHEN LIFT HAS BEEN USED FOR 2-3 DAYS

4. Operation instruction

4.1 Precautions during operation

Remark: Only authorized staff can adjust the system pressure on the power unit.

4.1.1 Check all the hydraulic oil hoses and connections before use. The lift can only be used if there are no leakages.

4.1.2 The lift should not be used if the safety devices fail or do not perform the required safety function.

4.1.3 The lift shall not rise or lower any vehicle if the center of gravity of the vehicle is not within the supporting range of the regulation show within the manual. Otherwise, Jema Autolifte or the distributor will not bear any responsibility for the consequence resulted from the wrong operation.

4.1.4 The staff or operators shall be in a safe position when the lift rise or lower.

4.1.5 When the lift with vehicle reaches a desired height, **ALWAYS lower the lift to the safety locks**, and main switch must be turned off before the vehicle is repaired so as to prevent non-operator or unauthorized person from pressing any button which can jeopardize the safety of anyone around or under the vehicle.

4.1.6 REMEMBER never work at or under the vehicle without the lift is set in safety lock. Never allow anyone stepping in under or nearby the lift when raised or lowering.

4.2 Control box panel description

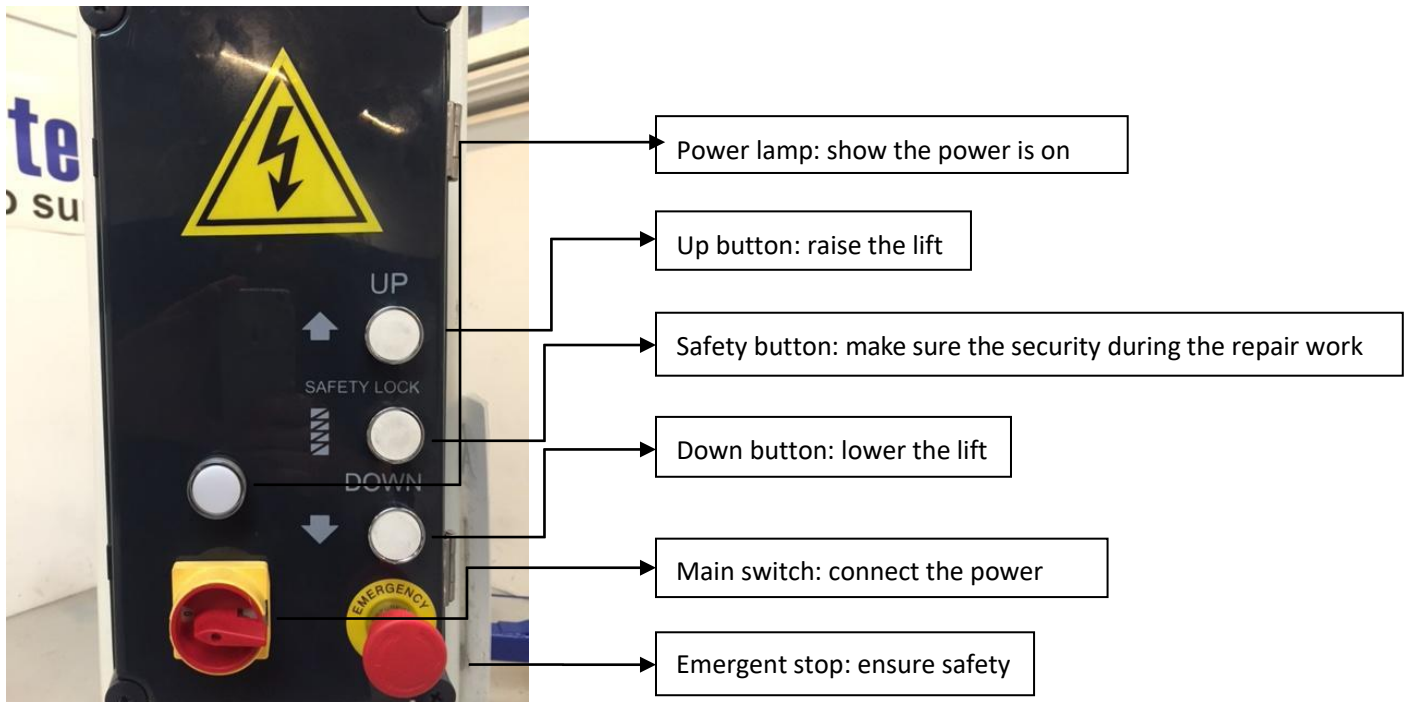

4.3 Flow chart for operation

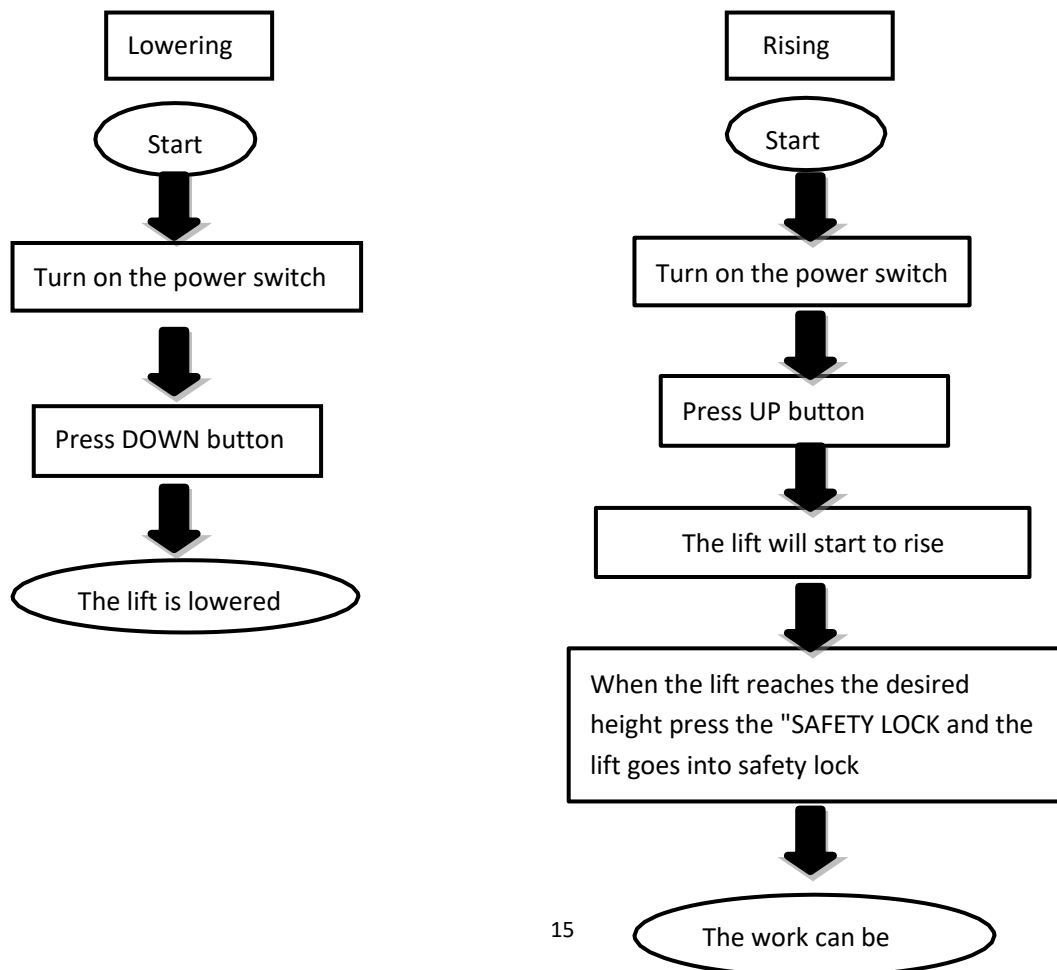

4.4 Operation

Adjust the lift -> The lift is calibrated by the calibration wires -> If the lift is not rise up equally on both carriages, the adjust the calibration wires.

The lift should be raised and lowered 3 to 4 times and then the hydraulic system has been vented.

Raise the lift

- 1、 Place the vehicle parallel between the columns.
- 2、 Turn the lift arms under the vehicle and place lifting platforms under the lifting points on the vehicle. Make sure that the vehicle's center of gravity is placed acc. The provisions of the manual
- 3、 Turn on the power switch, so the light turns on and power is being supplied to the lift. Press "UP" button until the lift platforms is touching the lifting points on the vehicle, check out again if lifting platforms are perfect and firmly placed on the lifting points on the vehicle and it is reasonable to continue to lift the vehicle.
- 4、 Push the "UP" Button when the vehicle has reached the desired height.
- 5、 Push the "Safety lock" Button so the lift lowers to the nearest safety lock.
- 6、 Check again that the vehicle is safely placed on the lifting platforms.
- 7、 If the vehicle is not placed safely then please lower the vehicle and start again from no. 2!
- 8、 If the vehicle is placed correct and safe on the lifting platforms, turn off the power switch and the work on the vehicle can start.

Lower the lift

1. Turn on the power switch.
2. Push the "DOWN" button, the lift will start to rise up the amount of seconds the lift has been adjusted to. Here after will the safety locks release and the lift will start to lower the vehicle until the lift is all the way down.
3. If more work must be carried out in a lower position, then the user must remember to press the "SAFETY LOCK" Button when the desired height is reached and turn off the power switch.
4. Turn off the power switch.
5. Pull out the lifting arms away under the vehicle and check whether any possibly tools or other objects around the vehicle.
6. Remove the vehicle from the lift

Note: It is important that the power is switched off when the lift is not in use!

4.5 Emergency lowering when the power is off

The carriage is **NOT** engaged:

- a. Pull off the electromagnets on both posts

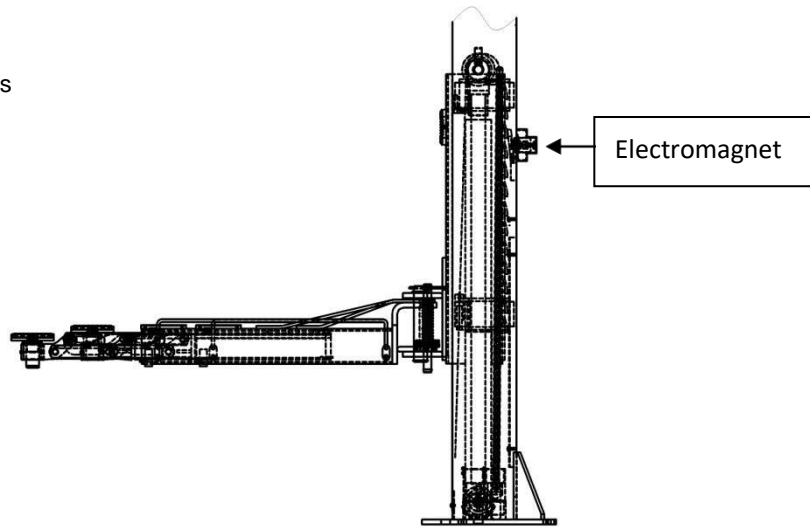

- b. Loosen the electrical valve of the power unit to lower the carriage.

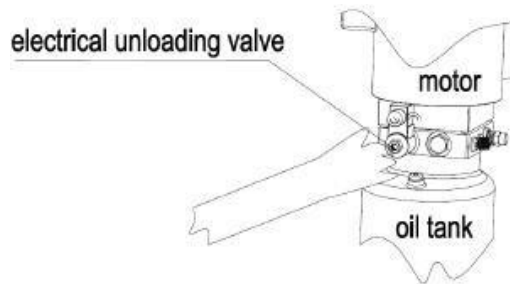

The carriage **IS** engaged:

- a. Screw off the fitting (opposite of the oil out-let) to connect the manual hydraulic pump. Press the handle of the Manual hydraulic pump (Manual hydraulic pump is optional) to supply oil to the cylinder to release the lock.

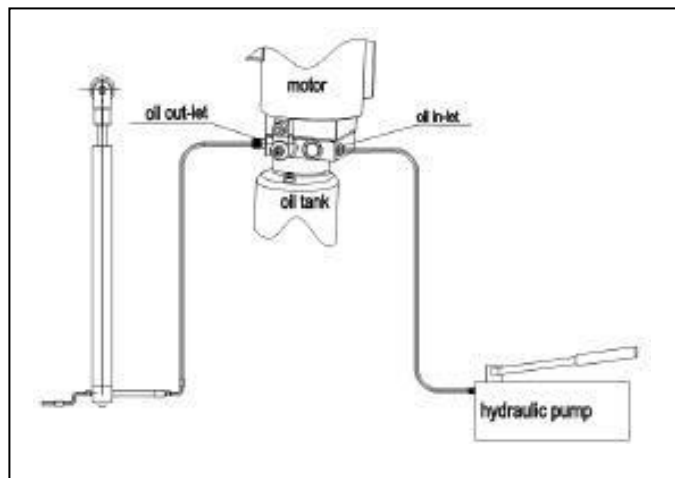
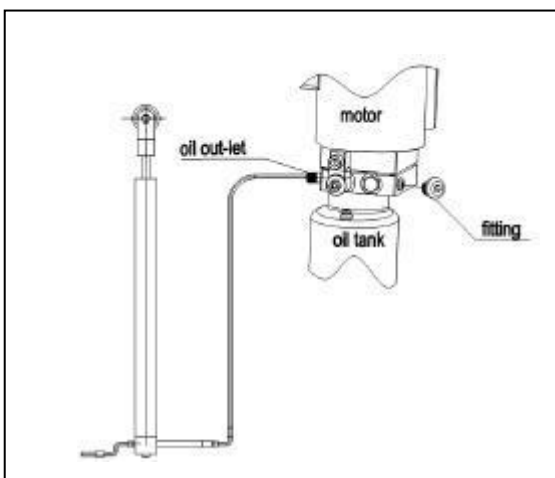

C .Pull off the electromagnets on the both posts.

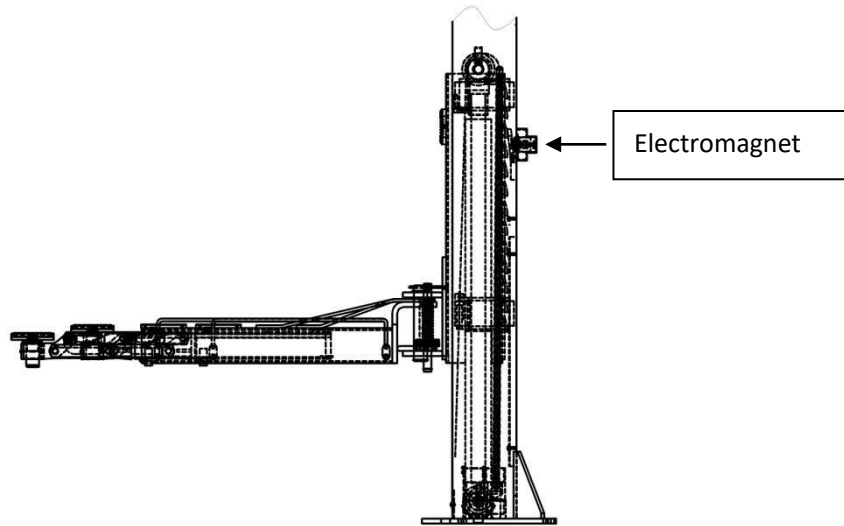

d. Lose the electrical valve of the power unit to lower the carriage.

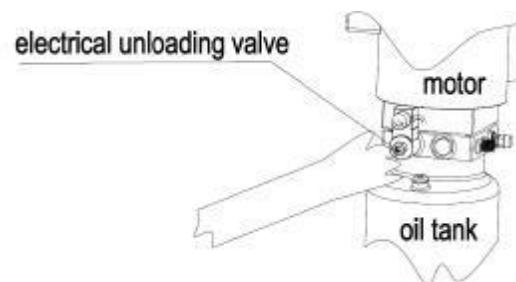

5. Trouble Shooting

ATTENTION: If you could not do the trouble shooting by your own, please contact Jema Autolifte or the distributor for help. You are requested to send us the series No. with detailed description of faulty of the lift or parts. We keep the right to ask for photos and pictures for diagnostics.

TROUBLE	CAUSE	SOLUTION
Murmurs from the lift	Check if the chain is placed correct	Adjust or change the chain
	Check the conduits are corrected mounted	Adjust or change the conduits
	Check if there are dirt in the column	Clean and grease the column
Motor does not run and lift will not rise	Check electric wires	Tighten all electric connections
	Motor is burned off	Change the motor
	The high limited switch is broken or has a loose wires connection	Change the high limited switch or connect the electric wires correct
Motor runs but the lift does not rise	The Motor turn the wrong way around	Check the 380V connection.
	There are dirt in the valves	Clean all the valves on the pump
	The gear pump is broken	Change the gear pump
	The lift is missing hydraulic oil	When the lift is lowered should the oil tank be $\frac{3}{4}$ full. (12L)
	The suction pipe in the tank is loose	Tighten the suction pipe
	There is dirt in the oil filter in the oil tank	Clean or change the oil filter and hydraulic oil
	The hydraulic oil hoses are not correct installed	Check whether the hydraulic hoses are properly acc. Assembly instructions
The lift is rising and lowering very slow	The pump pressure is not adjust correct	Adjust the pump pressure as instructed
	The Hydraulic piston is leaking oil	Change the seal or the piston
	There is dirt in the lowering valve	Clean or change the lowering valve
	The overflow valve is leaking oil	Change the overflow valve
	The top screw is the main piston is loose	Tighten the screw or change the piston
	There is dirt in the oil filter in the oil tank	Clean or change the oil filter and hydraulic oil
The lift may not be used!	The hydraulic oil is dirty	Change or order service check
	The temperature is too high/low	Max./min. Temp. 5° til 40°
	The safety devices do not work	Change the parts or order service check

6. Maintenance

Maintaining the lift is incredibly important to make sure the lift is safe to work with and the lift span is extended.

If the lift is not being maintained according to the requirements by a professional technical company will Jema Autolifte not be responsible for any accidents or errors that might occur with the lift.

THE FOLLOWING PARTS ARE NEEDED TO BE LUBRICATED.

S/N	Description
1	Top wire wheel
2	Wire rope
3	Chain wheel
4	Chain
5	Sliding block
6	Pin
7	Arm block
8	Lifting arm
9	Tray
10	Bottom wire wheel

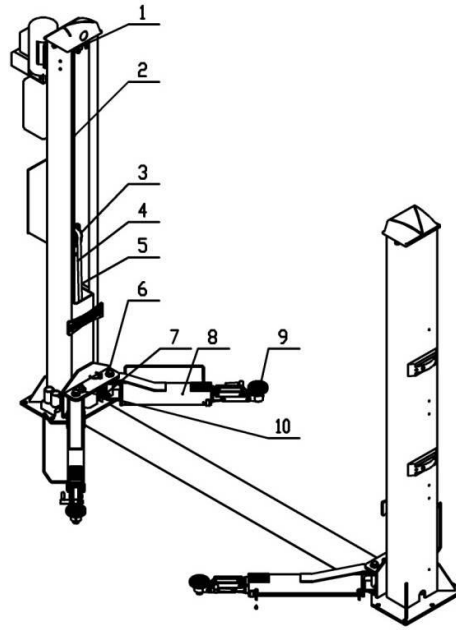

IMPORTANT: Check the lifting platforms are in perfect condition before using the lift!

6.1. DAILY PRE-OPERATION CHECK

The user should perform daily check. Daily check of safety latch system is very important – the discovery of device failure before needed could save you from expensive property damage, lost production time, serious personal injury, even death.

- Check safety lock audibly and visually while in operation.
- Check safety latch for free movement and full engagement with rack.
- Check hydraulic connections and hoses for leakage.
- Check chain connections for bends, cracks and looseness.
- Check cables connections for bends, cracks and looseness.
- Check for frayed cables in both raised and lowered position.
- Check snap rings at each roller and sheave.
- Check bolts, nut and screws. Tighten if needed.
- Check wiring and switches for damage.
- Keep base plate free of dirt, grease or any other corrosive substances.
- Check floor for stress cracks near anchor bolts.

6.2. WEEKLY MAINTENANCE

- Check the cleanness of the mobile parts.
- Check the safety device as previously described.
- Check hydraulic fluid level as follow: let the trolleys go up completely and in case they do not reach maximum height, add oil.
- Check and tighten bolts, nuts, and screws.

6.3. MONTHLY MAINTENANCE

- Check the tightening of screws.
- Check the hydraulic system seal and tighten the loose unions, if necessary.
- Check the greasing and wear condition of pins, rollers, bushes, of trolley structure as well as arms and relevant extensions, if necessary, replace the damaged parts by original spare parts.

6.4. YEARLY MAINTENANCE

- Lubricate chain.
- Grease rub blocks and column surface contacting rub blocks.
- Change the hydraulic oil. Good maintenance procedure makes it mandatory to keep hydraulic oil clean.

Due to operating temperature, type of service, contamination levels, filtration and chemical composition of fluid, the hydraulic oil may need to be changed more or less frequently.

If the above maintenance operations are carried out, it will make the lift is in perfect constitution every time the lift is used.

Jema Autolifte service has engineers and specialists running throughout Denmark, if it is outside Denmark, please call the Jema Autolifte distributor for advice.

If the user against all expectations, does not care out the lift annual compulsory service inspection will the warranty of the product be cancelled and Jema Autolifte disclaims all liabilities on the lift.

Contact Jema Autolifte service on tel. (+45) 48180300 or mail service@jemaautolifte.dk and get a good free quote on statutory servicing of lift. (Only possible for Danish clients)

7. ANNEX -> ANNEX1. Shipping Sheet

S/N	DESCRIPTION	PART NO	MATERIAL	Q'TY
1	Main and assistant post	JA4200T-C-A1	Component	2
2	Carriage	JA4200T-C -A2	Component	2
6	Power unit	JA4200T-C -B5-B6	Component	1
7	Assistant cylinder	JA4200T-C -A5-B4	Component	1
8	Main cylinder	JA4200T-C -A5-B5	Component	1
9	Electrical system	JA4200T-C -A5	Component	1
		Control box		1
		Electromagnet and its cover		1
10	Wire rope L=8785mm	JA4200T-C -A6	Component	2
11	Long arm	JA4200T-C -A7	Component	2
12	Short arm	JA4200T-C -A8	Component	2
13	Top bar	JA4200T-C -A9	Welding piece	1
14	Cover plate	JA4200T-C -A10	Q235A	1
15	Right packing frame	JA4200T-C -A30-B1		
	Topper plate cover	JA4200T-C -A16	ABS	2
16	Left packing frame	JA4200T-C -A30-B2		
20	Carton(include the following parts)			
22	Pin	A12	Component	4
23	Height adapter	JA4200T-C -A11	Q235A	4
24	Foot protector	A9-B3	Welding piece	2
25	Foot protector	JA4200T-C -A7-B5	Component	2
26	Tray	JA4200T-C -A7-B4	Component	4
27	Pulling rod	JA4200T-C -A2-B1	Component	4
28	Oil hose L=2550mm	JA4200T-C -B4-B1	Component	1
29	Oil hose L=2880mm	JA4200T-C -B4-B2	Component	1
30	Safety plate	JA4200T-C -A13	45	4
32	Electromagnet cover	JA4200T-C -A15	ABS	4
34	Positioning block	JA4200T-C E-A17	Q235A	4
35	Oil hose cover	JA4200T-C -A18	Q235A	6
36	Chain protection	JA4200T-C -A1-B5		2
37	Chain protection hook	JA4200T-C -A1-B6	Welding piece	4
38	Door-opening protection	JA4200T-C -A7-B10	Rubber	2
39	Bolt	M8*30	Standard piece	4
41	Screw	M8*12	Standard piece	8
42	Screw	M5*10	Standard piece	24
43	Screw	M5*20	Standard piece	12
44	Screw	M6*8	Standard piece	4
45	Screw	M6*16	Standard piece	4

WE ARE HERE TO SURPRISE!

46	Screw	M8*25	Standard piece	4
47	Flat washer	6	Standard piece	8
48	Flat washer	10	Standard piece	4
49	Spring washer	10	Standard piece	4
50	Nut	M6	Standard piece	8
51	Nut	M0	Standard piece	4
52	Circlip for shaft	50	Standard piece	4
53	Expansion bolt	M16*160	Standard piece	10

2, Overall Diagram

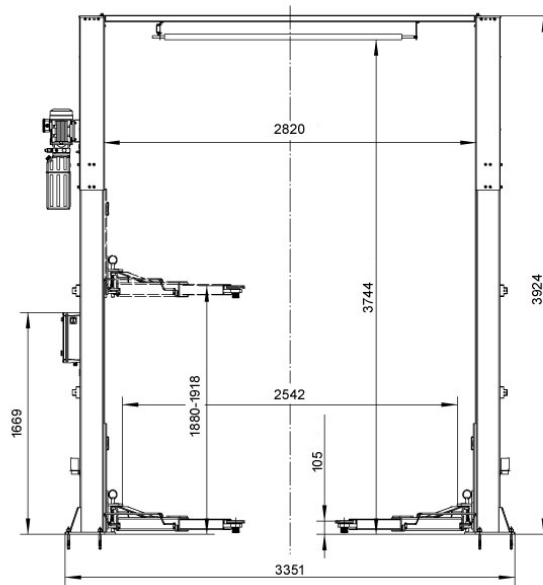

ANNEX3, Space Required

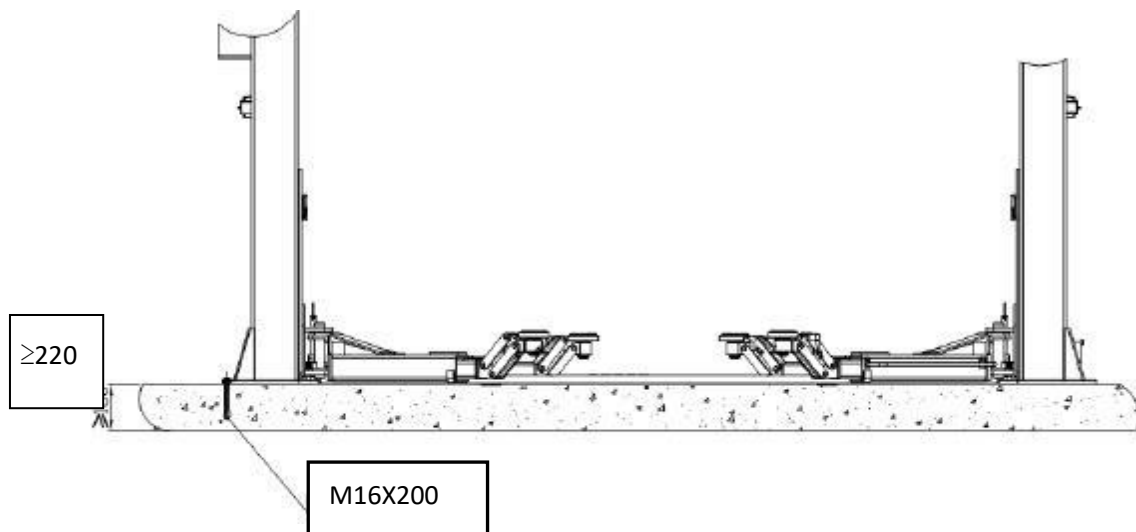



ANNEX4, Hydraulic Connection

- 1、 Main cylinder
- 2、 Assistant cylinder
- 3、 Electrical unloading valve
- 4、 Throttle valve
- 5、 Motor
- 6、 Coupling
- 7、 Gear pump
- 8、 Single-way valve
- 9、 Overflow valve
- 10、 Anti-surge valve
- 11、 Cushion valve

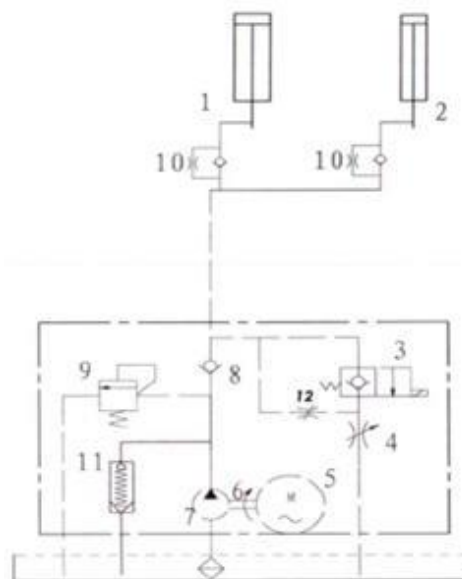

JA4200T-CF

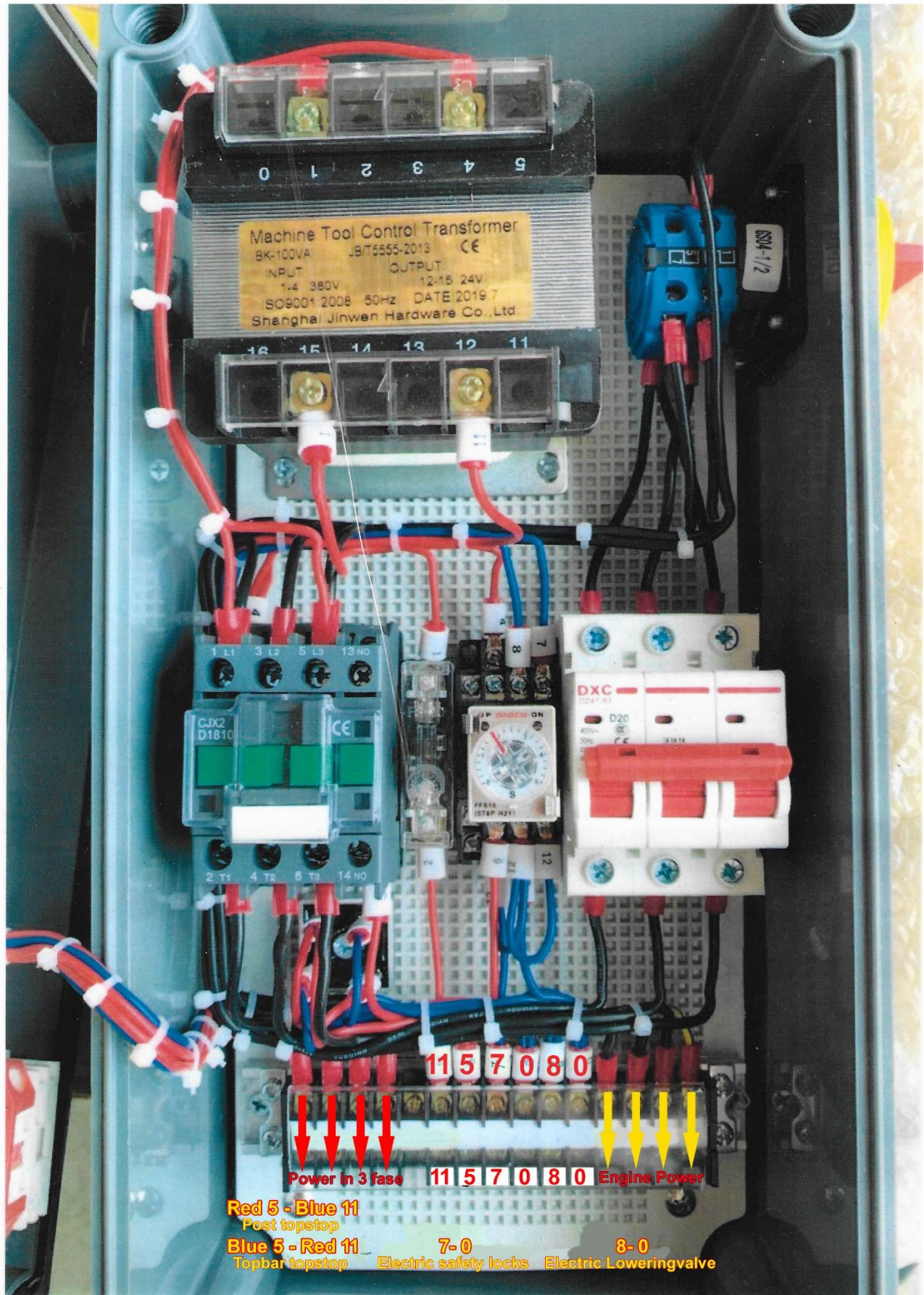

ANNEX 6, Wiring Diagram

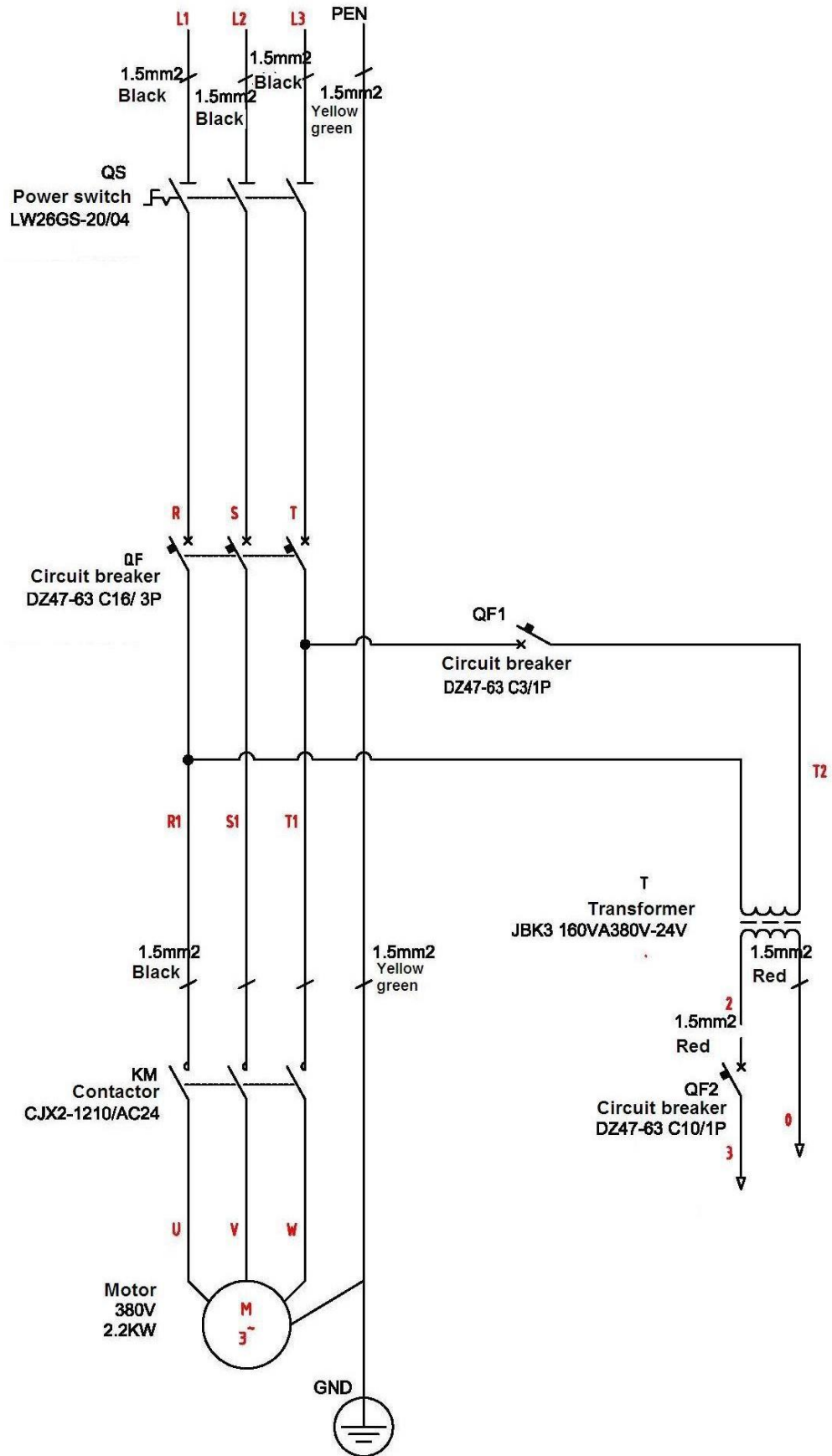

WE ARE HERE TO SURPRISE!

S/N	PART NO	DESCRIPTION	SPEC	Q'TY	REMARK
1	VD	RECTIFIER	KBPC5A-35A	1	
2	YV	ELECTROVALVE	DC24V	1	
3	YA	ELECTROMAGNET	MQZ2-10/DC24	4	
4	C	CAPACITOR	4700UF-50V	1	
5	JBK	TRANSFORMER	JBK3-100VA	1	
6	HL	POWER LAMP	AD17	1	
7	SQ1	LIMIT SWITCH	8104	1	
8	KM	AC CONTACTOR	CJX2-1210/AC24	1	
9	HK	POWER SWITCH	LW26GS-20/04	1	
10	FU2	FUSE	5A	1	
11	FU1	FUSE	16A/32A	3/2	
12	FU	FUSE	10A	1	
13	M	MOTOR	380V 220V 2.2KW	1	
14	SB3	BUTTON	Y090	1	DOWN
15	SB2	BUTTON	Y090	1	LOCK
16	SB1	BUTTON	Y090	1	UP
17	KA	RELAY	LY2N/AC24V	1	
18	KT	TIME RELAY	ST6PA-5S/AC24	1	
19	SB4	EMG. STOP	Y090	1	

ANNEX 7, Exploded drawing Parts of power unit and lift

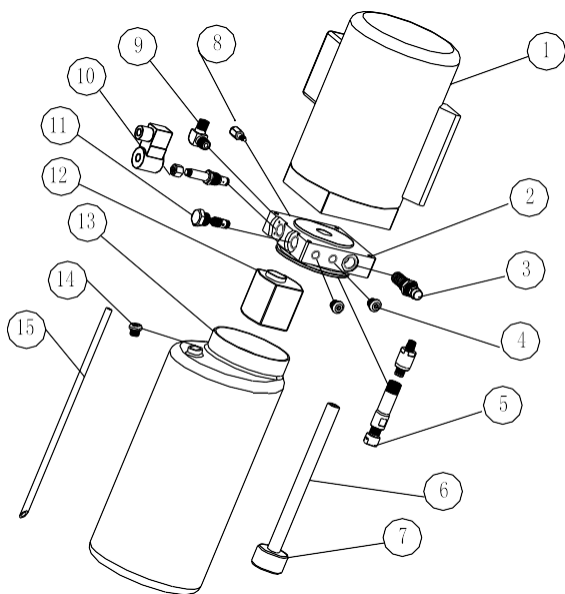

S/N	DESCRIPTION	Q'TY
1	MOTOR	1
2	VALVE BOARD	1
3	OVERFLOW VALVE	1
4	FITTING	2
5	CUSHION VALVE	1
6	ABSORBING OIL PIPE	1
7	OIL FILTER	1
8	THROTTLE VALVE	1
9	OIL HOSE TIE-IN	1
10	ECTRP,AGMETOC UNLOADING VALVE	1
11	SINGLE-WAY VALVE	1
12	GEAR PUMP	1
13	OIL TANK	1
14	OIL TANK COVER	1
15	OIL BACK PIPE	1

WE ARE HERE TO SURPRISE!

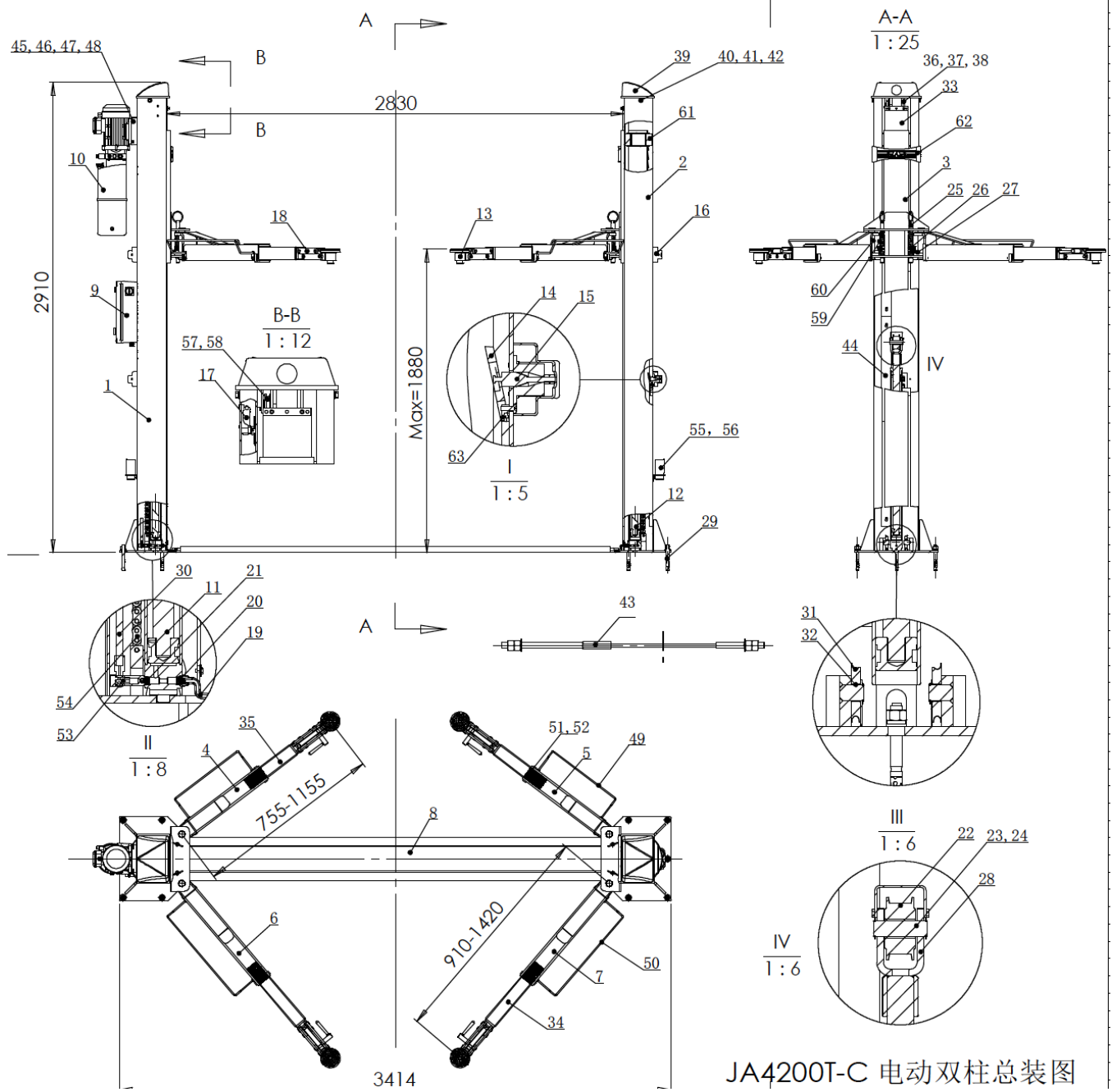

WE ARE HERE TO SURPRISE!

No.	Drawing No.	Name	Qty.
1	JA4200T-C-1000-01-00	Main Post	1
2	JA4200T-C-1000-02-00	Assistant Post	1
3	JA4200T-C-2000-01-00	Carriage	2
4	JA4200T-C-3000-06-00A	Short arm A	1
5	JA4200T-C-3000-06-00B	Short arm B	1
6	JA4200T-C-3000-01-00A	Long arm A	1
7	JA4200T-C-3000-01-00B	Long arm B	1
8	JA4200T-C-4000-00	Cover Assembly	1
9	JA4200T-C-7000-01	Control Box	1
10	No drawing No.	Power Unit	1
11	JA4200T-C-5000-01	Main Piston	1
12	JA4200T-C-5000-02	Assistant Piston	1
13	JA4200T-C-3000-02-10-00	Lifting Platform	4
14	JA4200T-C-1000-07	Safety catch	4
15	JA4200T-C-1000-06	Electro Magnet	4
16	JA4200T-C-1000-13	Magnet Cover	2
17	JA4200T-C-1000-16	Limit Switch	1
18	JA4200T-C-3000-00E	Hight Adaptor	4
19	JA4200T-C-6000-02	Oil Hose	1
20	JA4200T-C-6000-01	Fitting	2
21	JA4200T-C-6000-03	Long Fitting	1
22	JA4200T-C-5000-04	Chain Wheel	2
23	JA4200T-C-5000-05	Axle	2
24	SF-2545	Bushing	2
25	JA4200T-C-2000-05	Pull bar	4
26	JA4200T-C-2000-06	Arm lock	4
27	JA4200T-C-3000-04	Semi lock	4
28	JA4200T-C-5000-03-00	Wheel holder	2
29		Expansion Bolt	10
30	JA4200T-C-6000-05	Oil hose	1
31	JA4200T-C-1000-04	wheel	4
32	SF-2514	Bushing	4
33	JA4200T-C-1000-15	Cover	2
34	JA4200T-C-3000-02-01-00	Inner arm long	2
35	JA4200T-C-3000-07-01-00	Inner arm short	2
36	JA4200T-C-1000-12	Hook	4
37		Flat washer M6	4
38		Nut M6	4
39	JA4200T-C-1000-14	Post top	2
40		M12*25 Nut	4
41		M12 Flat washer	4
42		M12 Spring washer	4
43	JA4200T-C-6000-06	steel wire	2

WE ARE HERE TO SURPRISE!

44	JA4200T-C-1000-11	oil hose cover	7
45		M8*30 nut	4
46		M8 Spring washer	4
47		M8 Flat washer	4
48		M8 Nut	4
49	JA4200T-C-3000-08-00	Foot Protection A	2
50	JA4200T-C-3000-05-00	Foot Protection B	2
51	JA4200T-C-3000-03	Rubber	4
52		M5*12 nut	16
53	JA4200T-C-6000-04	Fitting	1
54	JA4200T-C-5000-07	Chain	2
55	JA4200T-C-1000-01-05	Adaptor holder	2
56	JA4200T-C-1000-17	Adaptor	4
57	JA4200T-C-1000-04	wheel	2
58	SF-2519	Bushing	2
59	JA4200T-C-2000-02	Spring	4
60	JA4200T-C-2000-07	Axle	4
61	JA4200T-C-2000-03	Slide	16
62	JA4200T-C-2000-04	Rubber	2
63	JA4200T-C-1000-08	Safety catch	4

Annex 8. Spare parts list

Spare parts list---electrical system

S/N	Material No.	Description	Spec.	Unit	Q'ty	Remark
1	321001	Power switch	LW26GS-20/04	Pcs	1	
2	328064	Button	Y090	Pcs	3	
3	328003	Power lamp	AD17-22G-AC24	Pcs	1	
4	320009	Transformer	JBK-100VA220V-24V	Pcs	1	The outlook is the same as item 5
5		Transformer	JBK-100VA230V-24V	Pcs	1	The outlook is the same as item 5
6		Transformer	JBK-100VA240V-24V	Pcs	1	The outlook is the same as item 5
7	320019	Transformer	JBK-100VA380V-24V	Pcs	1	
8		Transformer	JBK-100VA400V-24V	Pcs	1	The outlook is the same as item 5
9		Transformer	JBK-100VA415V-24V	Pcs	1	The outlook is the same as item 5

WE ARE HERE TO SURPRISE!

10	328005	AC contactor	CJX2-1210/AC24	Pcs	1	
11	540035	Fuse holder	TFBR-102	Pcs	1	
12	328008	Fuse holder	RT18-32X	Pcs	3	
13	328010	Fuse	16A (10*38)	Pcs	6	
14	32801	Fuse	32A (10*38)	Pcs	6	
15	328011	Fuse	5A (6*30)	Pcs	2	
16	540088	Fuse	10A (6*30)	Pcs	2	
17	321024	Limit switch	ME8104	Pcs	1	

WE ARE HERE TO SURPRISE!

18	323002	Terminal block	TB1512L	Pcs	1	
19	328026	Rectifier	KBPC5A-35A	Pcs	1	
20	328014	Capacitor	4700UF/50V	Pcs	1	
21	328074	Control box		Pcs	1	
22	328072	Relay	LY2NJ/AC24	Pcs	1	
23	328073	Relay seat	PTF-08A	Pcs	1	
24	328019	Time relay	ST6PA-5S/AC24V	Pcs	1	
25	328020	Time relay seat	PYF-08A	Pcs	1	

Spare parts list---machine part

S/N	DRAWING#	DESCRIPTION	Q'TY	MATERIAL	REMARK
012	JA4200T-C-A1-B1	Down wheel	1	45#	
013	JA4200T-C -A11	Height adapter	4	Welding piece	130MM
016	JA4200T-C -A13	Safety plate	4	45#	
017	JA4200T-C -A17	Positioning block	4	Q235A	
020	JA4200T-C -A14	Electromagnet	4	Component	
103	JA4200T-C -A3-B1	Up wheel	2	45#	
815	JA6214F-A3-B5	Spring	4	Standard piece	
816	JA6214F-A3-B3	Teeth block	4	Q235A	
223	JA4200T-C -A7-B10	Door-opening protection	2	Rubber	
224	JA4200T-C -A7-B1	Sliding block	16	Nylon 1010	
909	JA4200T-C -A7-B2	Rubber pad	4	Rubber	
911	JA4200T-C -A7-B4-C4	Rubber pad	4	Rubber	
921	JA6214F-A4-B3	Teeth block	4	Q235A	
401	JA4200T-C -A4-B2	Oil hose	1	Component	2880mm
402	JA4200T-C -A5-B10	Short tie-in	1	35#	With anti-surge valve
403	JA4200T-C -A5-B-4	Assistant cylinder	1	Component	
409	JA4200T-C -A5-B3	Chain wheel	2	45#	
417	JA4200T-C -A5-B6	Power unit	1	Component	
420	JA4200T-C -A5-B5	Main cylinder	1	Component	
421	JA4200T-C -A4-B1	Main oil hose	1	Component	2555mm
422	JA6214-A5-B4	Long tie-in	1	Component	With anti-surge valve
603	JA4200T-C -A1-B5	Chain protection	2	Q235A	2700

Annex 9, Size and weight requirement for the vehicle

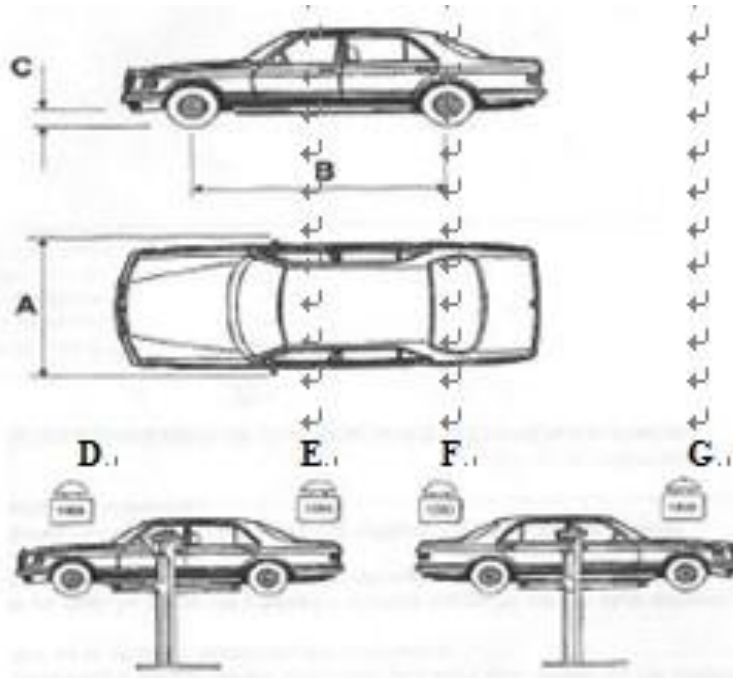

Model No.	A (mm)	B (mm)	C (mm)	D (T)	E (T)	F (T)	G (T)
JA4200T-CF	2400	2900	100	2.3	1.9	1.9	2.3

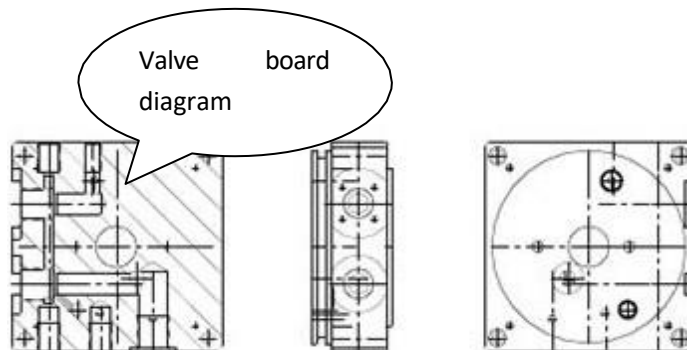

Annex 10, CE Certificate

EC Declaration of Conformity (informative)

We (name of applicant) Jema Autolifte A/S
of (address of applicant) Industrihegnet 2, 4030 Tune, Denmark

hereby declare that the equipment submitted for Type Approval is in conformity with the requirements of following EU Directives:

2006/42/EC The Machinery Directive
2014/30/EU Electromagnetic Compatibility Directive

We hereby declare that:

Equipment Two Post Lift
Model number JA4200T-CF
Serial Number 2020100301

is in conformity with the applicable requirements of the following documents

Ref. No.	Title	Edition/date
2006/42/EC	Essential health and safety requirements relating to the design and construction of machinery	Annex I
EN 60204-1	Safety of machinery - Electrical equipment of machines -- Part 1: General requirements	2018
EN 1493	Vehicle lifts	2010
EN 61000-6-4	Electromagnetic compatibility (EMC) - Part 6-4: Generic standards - Emission standard for industrial environments	2019
EN 61000-6-2	Electromagnetic compatibility (EMC) - Part 6-2: Generic standards - Immunity for industrial environments	2019

The machine has been the subject of a type examination by CEM International Ltd (Notified Body Number 1942) & granted Type Examination Certificate number: C-20-1003-20-01-A

I hereby declare that the equipment named above has been designed to comply with the relevant sections of the above referenced specifications and is in accordance with the requirements of the above Directive(s):

Signed by:

Full Name: Kasper
Title: Director
Location: Tune, Denmark
Date: 03, Oct, 2020



Document ref. No.
F-20-1003-20-01-A

The technical documentation only for the machinery certified to the Test Standards as required by the Machinery Directive, is available from:

Name: CEM International Ltd
Address: Westmead House Westmead Farnborough Hampshire GU14 7LP UK