

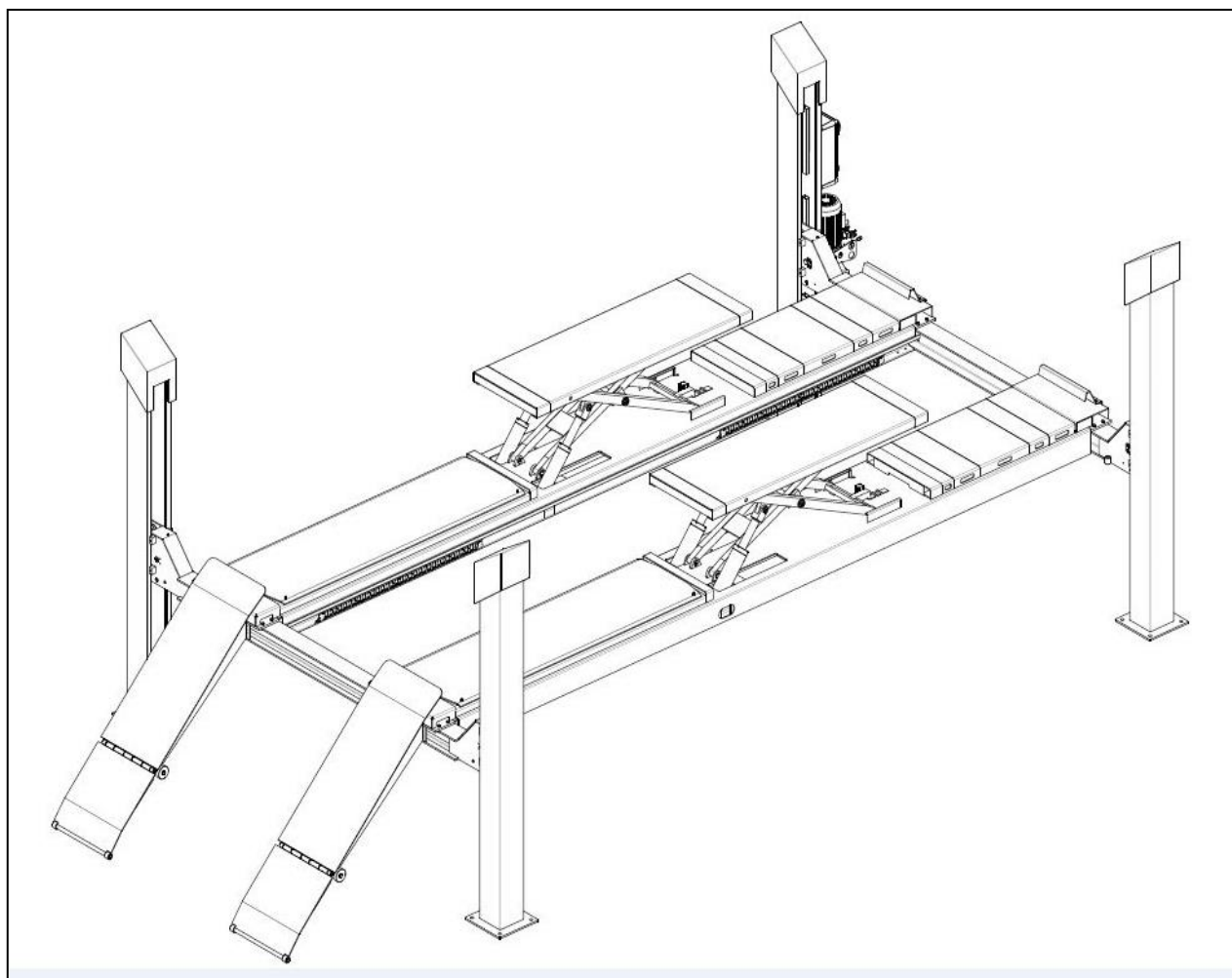

4 POST LIFT



USER'S MANUAL

HYDRAULIC AUTOMOBILE LIFT

Model:

JA5001F-E

Serial No.:

Year of manufacture:

Supplier:

Name: Jema Autolifte A/S

Address: Industrihegnet 2, 4030 Tune, Denmark

Tel: +45 48180300

E-mail: info@jemaautolifte.dk

AUTHORISED SERVICE CENTRE:

CONTENTS

Contents

Packing, transport and storage

Introduction

Chapter 1 Description of the machine

Chapter 2 Technical specifications

Chapter 3 Safety

Chapter 4 Installation

Chapter 5 Adjustment

Chapter 6 Operation

Chapter 7 Maintenance

Chapter 8 Troubleshooting

Chapter 9 Appendix

PACKING, TRANSPORT AND STORAGE



ALL PACKING, LIFTING, HANDLING, TRANSPORT AND UNPACKING OPERATIONS ARE TO BE PERFORMED EXCLUSIVELY BY EXPERT PERSONNEL

PACKING

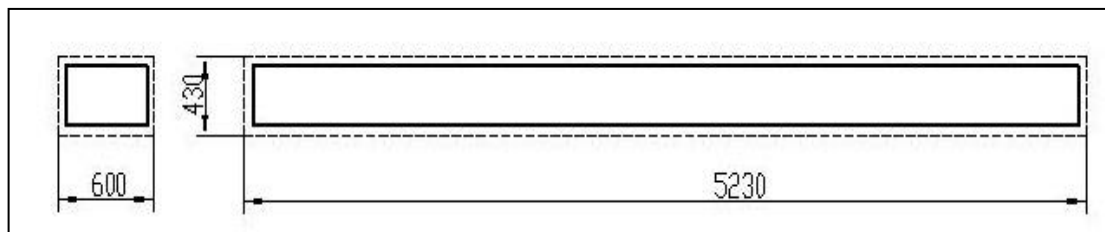

Picture 1 (packing dimension)

TRANSPORT



Packing can be lifted or moved by lift trucks, cranes or bridge cranes. In case of slinging, a second person must always take care of the load, to avoid dangerous oscillations.

At the arrival of the goods, check for possible damage due to transport operations. Also verify that all items specified in the delivery notes are included. In case of missing parts, it possible defects or damage due to transport operations. Also verify that all items specified in the delivery notes are included. In case of missing parts, possible defects or damage due to transport, the person in charge or the carrier must be immediately informed.

MACHINES ARE ALL HEAVY GOODS! DON'T MOVE OR LOAD THEM BY MANUAL. SAFETY IS THE MOST IMPORTANT.

Furthermore, during loading and unloading operation goods must be handling as shown in the picture.

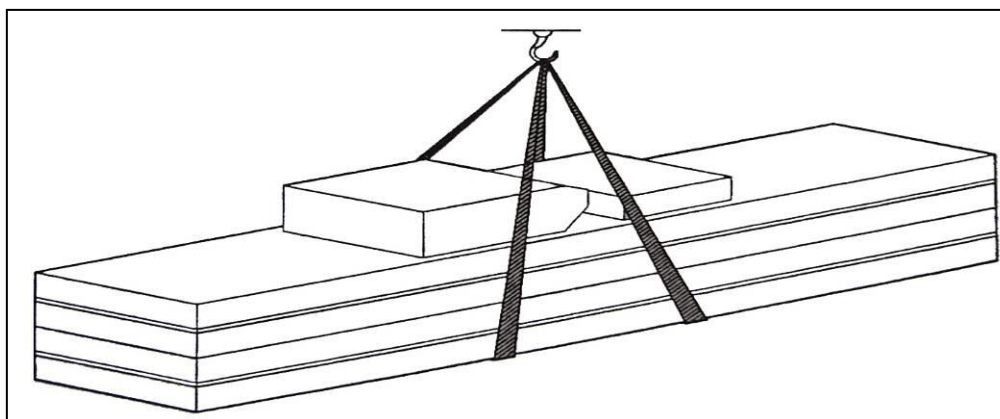

Picture 2 (Goods-lifted)

STORAGE:

Machines must be put in the house, if put them out, should do the anti-water things. Put them in the temperature between:-25~55°C



This manual has been prepared for workshop personnel expert in the use of the lift (operator) and technicians responsible for routine maintenance (maintenance fitter); read the manual before carrying out any operation with the lift and/or the packing. This manual contains important information regarding:

- The personal safety of operators and maintenance workers.
- The safety of installation
- The safety of operating lift.

CONSERVING THE MANUAL



This manual is an integral part of the lift, which should always accompany with. The manual must be kept in the vicinity of the lift, in an easily accessible place for the operator and maintenance staff must be able to locate and consult the manual quickly and at any time.

ATTENTIVE READING OF CHAPTER 3, WHICH CONTAINS IMPORTANT INFORMATION AND SAFETY WARNING



THE LIFT IS DESIGNED AND MADE AS THE STANDARD OF THE EUROPEANS.

The lifting, transport, unpacking, assembly, installation, starting up, initial adjustment and testing, extraordinary maintenance, repair, overhauls, transport and dismantling of the lift must be performed by specialized personnel from the licensed dealer or a service center authorized by the manufacturer.

The manufacturer declines all responsibility for injury to persons or damage to vehicles or objects when any of the above-mentioned operations has been performed by unauthorized personnel or when the rack has been subject to improper use.



This manual indicates only the operative and safety aspects that may prove useful to the operator and maintenance worker, I better understanding the structure and operation of the lift and for best use of the same.

In order to understand the terminology used in this manual, the maintenance and repair activities, the ability to interpret correctly the drawings and descriptions contained in the manual and be the country in which the machine has been installed.

The same applies to the maintenance fitter, who must also possess specific and specialized knowledge (mechanical, engineering) needed to perform the operations described in the manual in complete safety.

OPERATOR: person authorized to use the lift

MAINTENANCE FITTER: person authorized for routine maintenance of the lift.



MANUFACTURER HAS THE RIGHT TO MAKE LITTLE CHANGE FOR THE MANUAL IN ORDER TO IMPROVE THE TECHNOLOGY.

Chapter 1 DESCRIPTION OF THE MACHINE**Application:**

This lift of the main platform can lift which weight is not over 5000Kg and sub platform can lift which weight is not over 3500kg, and is suitable for vehicle tests, maintenance and care for various types of small automobiles. And the model for alignment is good for four-wheel alignment.

Features:

- The alignment level of the lift can be adjusted in high precision, which is the ideal equipment for four-wheel alignment (optional for alignment model).
- The position of the front wheel turntable (optional part) is adjustable so that the side slide plate can be fit for more cars (optional for alignment model).
- Device performs stable and reliable work with anti-breaking rope safety insurance.
- With second lifting trolley guide rail and can optionally add.

Equipment:

- Machine frame
- Lift frame
- Hydraulic system
- Control box

Basic frame:

Made of concrete

Frame:

Post, main and sub beam, front and back crossbeam.

Hydraulic Pump:

Make up for hydraulic pump, pump motor, oil tank.

Control box:

Control by electricity system.



The scissors lift is designed and built to lift vehicle to hold them in the elevated position in a closed workshop. All other use is unauthorized. In particular, the lift is not suitable for: washing and spray work, creating raised platforms or lifting personnel, use as a makeshift press for crushing purposes, use as good lift. And not to lift the vehicle whose weight exceeds the maximum weight.

Chapter 2 TECHNICAL SPECIFICATION

Lift dimension drawing:

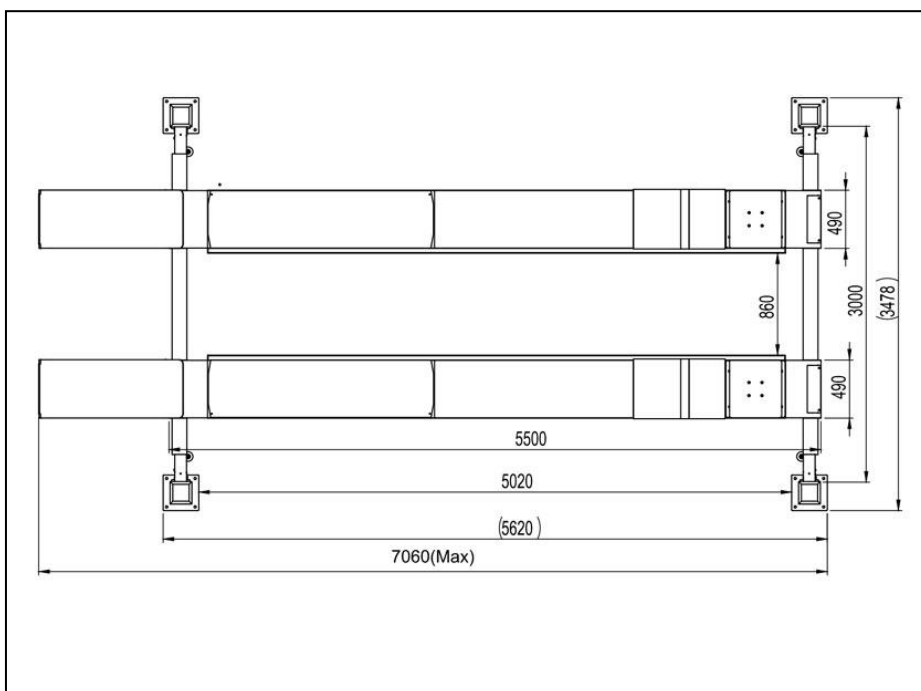
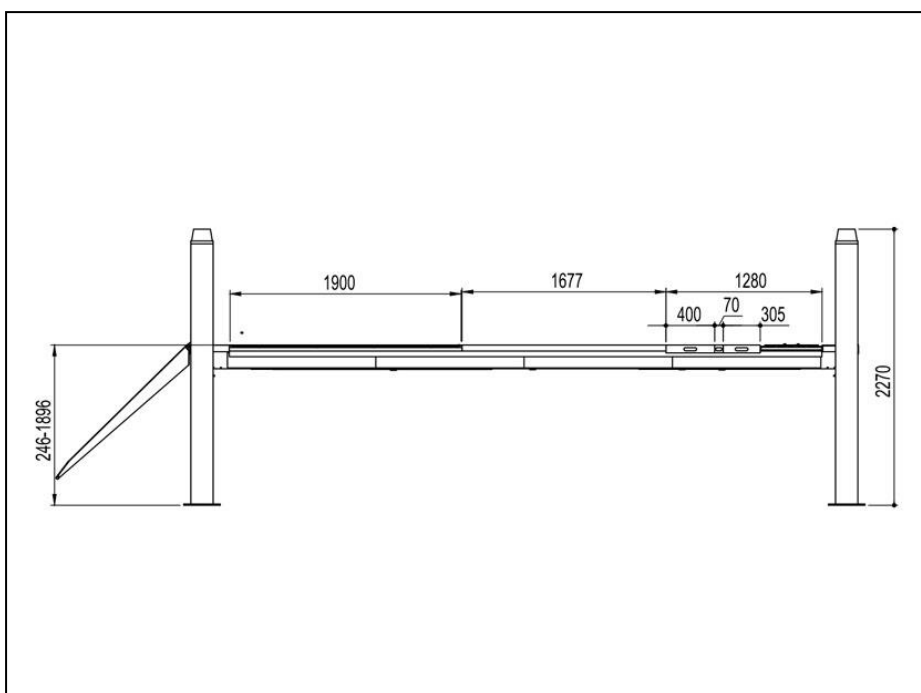

MOTOR PUMP:

- Type-----Y90L
- Power-----2.2KW
- Voltage-----AC 400V or 23V ±5%
- Frequency-----50 Hz
- Poles-----4
- Speed-----1450 r/min
- Building shape-----B14
- Isolation class-----F

PUMP:

Model-----C55
 Flux----- 4.3 cc/r(50HZ)/3.2cc/r(60HZ)
 Joint type-----direct joint
 Overflow valve:
 Setting pressure-----220 bar
 Adjustable working pressure-----150~300 bar

Chapter 2 TECHNICAL SPECIFICATION

INSTALLATION SCHEME FOR LIFT

NOTE: To install the lift it is necessary to execute suitable foundations with the following characteristics:

- Concrete type 425, the drying days is 15 days.
- Thickness of concrete ≥ 150 mm, the leveling of whole length ≤ 5 mm
- Perfect parallelism between holes.

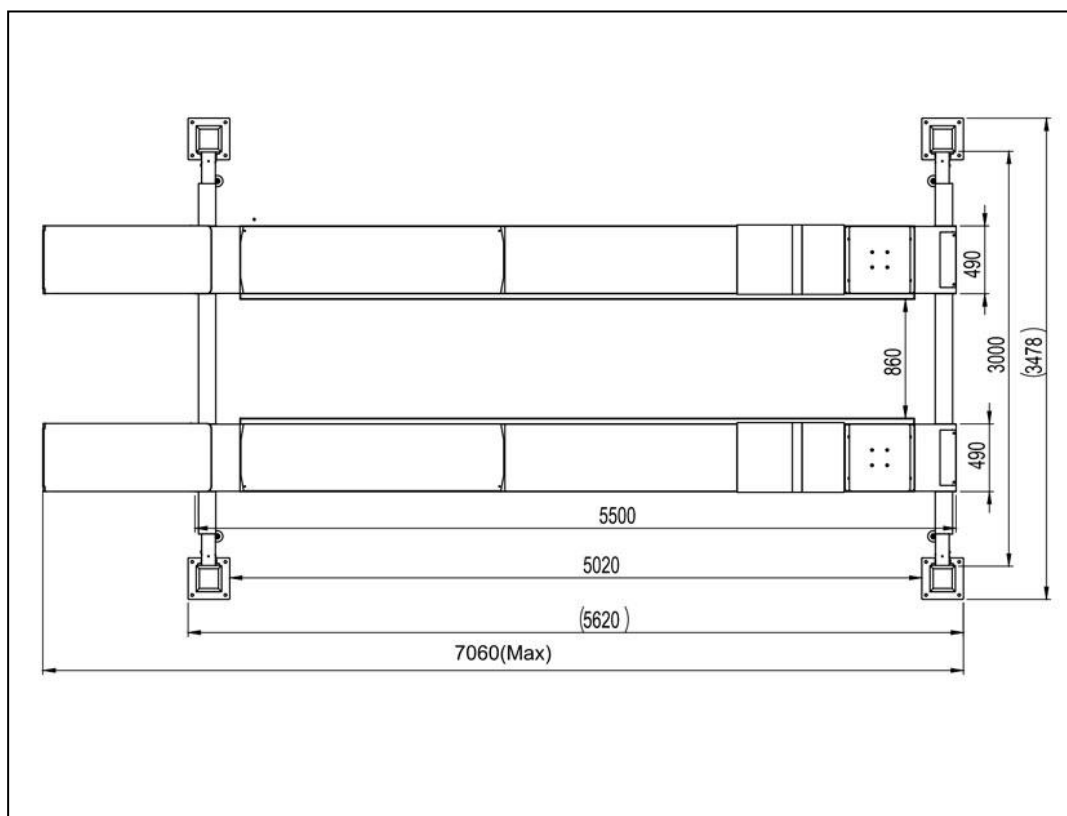

Picture 4 (Installation drawing)



The basic thickness of concrete and leveling are keys, one should not egregiously expect the ability of level adjustment of machine itself.

Chapter 3 SAFETY



Read this chapter carefully for there is important information of the safety for the operator or others in case of improper use of the lift is included.

In the following text there are clear explanations regarding certain situations of risk or danger that may arise during the operation or maintenance of the lift, the safety device installed and the correct use of such systems, residual risks and operative procedures to use (general specific precautions to eliminate potential hazards).



Lifts are designed and built to lift vehicles and hold them in the elevated position in an enclosed workshop. All other uses of the lifts are unauthorized. In particular, the lifts are not suitable for:

- Washing and cleaning work;
- Creating raised platforms for personnel or lifting personnel;
- Use as a press for crushing purposes;
- Use as elevator;
- Use as a lift jack for lifting vehicle bodies or changing wheels.



The manufacturer is not liable for any injury to persons or damages to vehicles and other property caused by the incorrect and unauthorized use of the lifts.

During lifting and lowering movements the operator must remain in the control station. The presence of persons inside the danger zone indicated is strictly prohibited.

During operations persons are admitted to the area beneath the vehicle only when the vehicle is already in the elevated position, when the platforms are stationary, and when the mechanical safety devices are firmly engaged.



DO NOT USE THE LIFT WITHOUT PROTECTION DEVICES OR WITH THE PROTECTION DEVICES INHIBITED.

FAILURE TO COMPLY WITH THIS REGULATION CAN CAUSE SERIOUS INJURY TO PERSONS, AND IRREPARABLE DAMAGE TO THE LIFT AND THE VEHICLE BEING LIFTED.

GENERAL PRECAUTIONS



The operator and the maintenance fitter are required to observe the prescriptions of safety regulation in force in the country of installation of the lift.

Furthermore, the operator and maintenance fitter must:

- Always work in the stations specified and illustrated in this manual;
- Never remove or deactivate the guards and mechanical, electrical, or other types of safety devices;
- Read the safety notices placed on the machine and the safety information in this manual.

In the manual all safety notices are shown as follows:

WARNING: indicates following operations that are unsafe and can cause minor



injury to persons and damage the lift, the vehicle or other property.

CAUTION: indicates possible danger that can result in serious injury to people and damage property.

RISK OF ELECTRIC SHOCK: a specific safety notice placed on the lift in areas where the risk of electric shock is particularly high.

Chapter 3 SAFETY

Risk and protection devices:

We shall now examine the risks that operators or maintenance fitters may be exposed to when the vehicle is standing on the platforms in the raised position, together with the various safety and protection devices adopted by the manufacturer to reduce all such hazards to the minimum:

For optimal personal safety and safety of vehicles, observe the following regulations:

- Do not enter the areas that are unsafe when vehicles are being lifted.
- Switch off the engine of the vehicle; engage a gear and the hand brake,
- Make sure the vehicle is positioned correctly on the platform.
- Be sure to lift only approved vehicles, never exceed the specified carrying capacity, maximum height, and projection (vehicle length and width);
- Make sure that there is no person on the platforms during up and down movements.

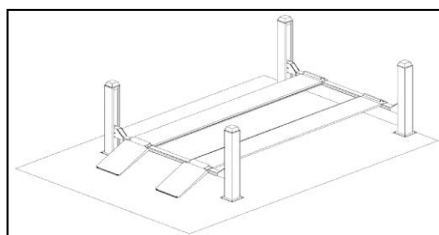

Picture 6

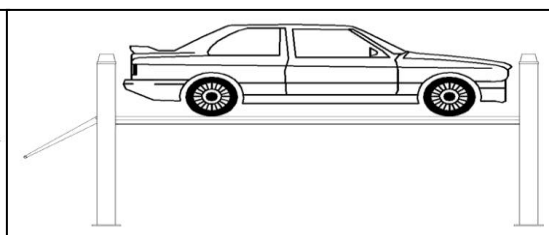

Picture 7



GENERAL RISKS FOR LIFTING OR DESCENT:

The following safety equipment are used to protect over loading or the possibility of engine failure.

In the condition of over loading, the overflow valve will open and directly return oil to the oil tank. (See Picture 8)

When the oil-pipe is burst in the circuit of hydraulic pressure or the steel line was broken, the safety tooth will work to limit the descent of platform. (See Picture 9)

Safety tooth and gear module are parts which guarantee the safety of personnel beneath the machine in failure condition of other protections. So make sure the integrity of gear module and that the safety tooth has occluded completely.

There is nothing abnormal should be left on the safety modules to prevent safety gear from occlude normally.



Picture 8



Safety pawl in case of cable broken

Main safety pawl

Picture 9

**RISKS FOR PERSONNEL**

This heading illustrates potential risks for the operator, maintenance fitter, or any other person present in the area around the lift, result from incorrect use of the lift.

**RISK OF CRUSHING**

Possible if the operator controlling the lift is not in the specified position at the control panel.

When the platforms (and vehicle) are lowering the operator must never be partly or completely underneath the movable structure. Always remain in the control zone.

**RISK OF IMPACT**

Caused by the parts of the lift or the vehicle that is positioned at head height.

When, due to operational reasons, the lift is stopped at relatively low elevations personnel must be careful to avoid impact with parts of the machine not marked with special color.

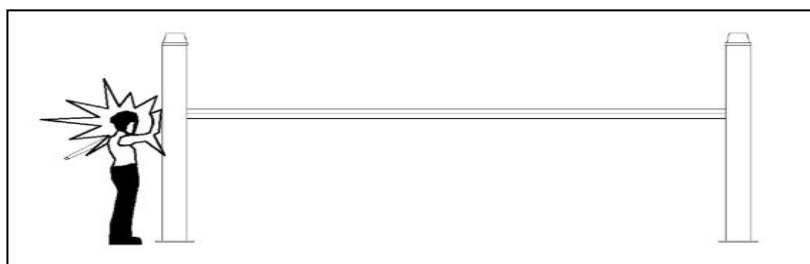

Picture 10

**RISK OF OPERATOR FALLING**

No person is permitted in the platform or in the vehicle when the lift lifting and lowering.

RISK OF VEHICLE MOVING

Caused by operations that involving the application of force sufficient to displace the vehicle.

RISK OF VEHICLE FALLING FROM LIFT

This hazard may cause of incorrect positioning of the vehicle on the platforms, incorrect stopping of the vehicle, or vehicles of dimensions that are not compatible with the capacity of the lift.



NEVER ATTEMPT TO PERFORM TESTS BY DRIVING THE VEHICLE WHILE IT IS ON THE PLATFORMS
NEVER LEAVE OBJECTS IN THE LOWERING AREA OF THE MOVABLE PARTS OF THE LIFT.

**RISK OF SLIPPING:**

Caused by lubricant contamination that of the floor around the lift.

The area beneath and immediately surrounding the lift and also the platforms must be kept clean.

Remove any oil spills immediately.

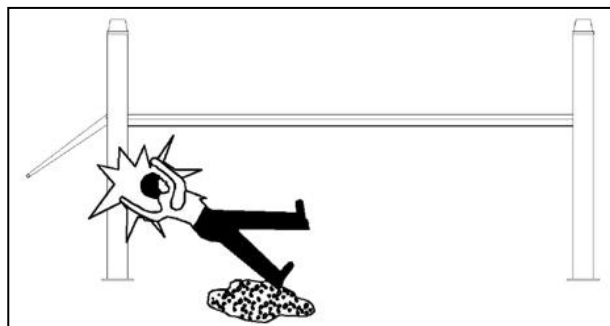

Picture 11

**RISK OF ELECTRIC SHOCK**

Risk of electric shock that in area of the lift housing electrical wiring.

Do not use jets of water, steam solvents or paint next to the lift, and take special care to keep such substances clear of the electrical control panel.

**RISKS RELATED TO INAPPROPRIATE LIGHTING**

The operator and the maintenance fitter must be able to assure that all the areas of the lift are properly and uniformly illuminate compliance with the laws in force in the place of installation.



NEVER EXCEED THE MAXIMUM CARRYING CAPACITY OF THE LIFT, MAKE SURE THE VEHICLES TO BE LIFTED HAVE NO LOAD.



IT IS THEREFORE ESSENTIAL TO ADHERE SCRUPULOUSLY TO ALL REGULATIONS REGARDING USE, MAINTENANCE AND SAFETY CONTAINED IN THIS MANUAL.



SKILLED AND AUTHORIZED PERSONNEL ONLY SHOULD BE ALLOWED TO PERFORM THESE OPERATIONS, FOLLOW ALL INSTRUCTIONS SHOWN BELOW CAREFULLY, IN ORDER TO PREVENT POSSIBLE DAMAGE TO THE CAR LIFT OR RISK OF INJURY TO PEOPLE. BE SURE THAT THE OPERATING AREA IS CLEARED OF PEOPLE.

INSTALLATION REQUIREMENTS

-The car lift must be installed according to the specified safety distances from walls must be 1000 mm at least, taking into consideration of the necessary space to work easily. Further space for the control site and for possible runways in case of emergency is also necessary; the room must be previously arranged for the power supply and pneumatic feed of the car lift.

-The room must be 4000 mm in height, at least, the car lift can be placed on any floor, if it is perfectly level and sufficiently resistant. ($\geq 250 \text{ kg/cm}^2$)

-All parts of the machine must be uniformly lit with sufficient light to make sure that the adjustment and maintenance operations specified in the manual can be performed safely, and

without areas of shadow, reflected light, glare and avoiding all situations that could give rise to eye fatigue.

-The lighting must be installed in accordance with the laws in force in the place of installation.

-The thickness and leveling of the base concrete are essential

-Thickness of concrete $\geq 150 \text{ mm}$, the leveling of whole length $\leq 10 \text{ mm}$.

-All parts of the machine must be uniformly lit with sufficient light to make sure that the adjustment and maintenance operations can be performed safely, and without reflected light, glare that could give rise to eye fatigue.

-The integrity of arrived goods should be checked before the lift is installed.

-Moving and installing lift should follow the process as the picture instructs.

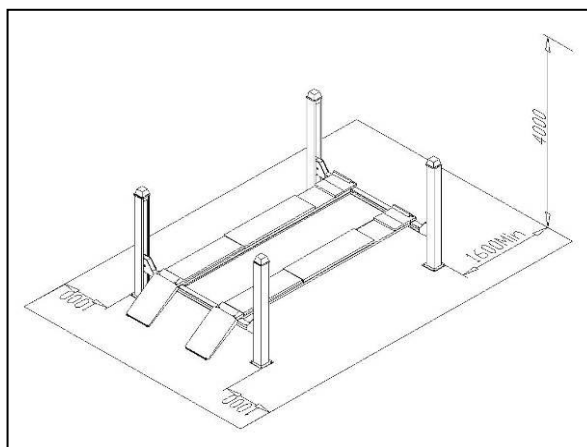

Picture 12

Crossbeam installation:

-Fix the front and back crossbeam on the floor. (The crossbeam has solenoid air valve fix on the frontage of the vehicle head, and which has the installation screw fix on the left side of the vehicle head.)

-Put a wood or an iron under the crossbeam in order to raise it to 100-300 mm.

-Fix eight nylon blocks of the crossbeam.

Platform installation:

- Put two platforms on the crossbeam, the main platform (with the cylinder) should be located on the left side of the moving vehicle direction, the slave platform is located on the right side, the rail for the jacking beam should be put inside.
- Check two platforms and the diagonal of two crossbeams are straight.

Post installation:

- Put four posts on each side of the crossbeams and fix the nuts on the roof of the post with steel cable, put the safety teeth bar trough the limit axis, also fix the nuts on the roof of the post. Disassemble the bolt under the insurance in the post.



The post is fixed at the end of the crossbeam and to make the nylon-block keep close to it. Main post (has pumping station) fix on the Left-hand side in front of the vehicle advance and other posts' fix need to pay attention to that the orifice of safety bar lean too outside.

Rolling jack installation (optional part):

- Adjust the distance of the rolling jack; put the rolling jack between the slide tracks.
- Adjust the sub beam to make sure the sliding of the rolling jack.

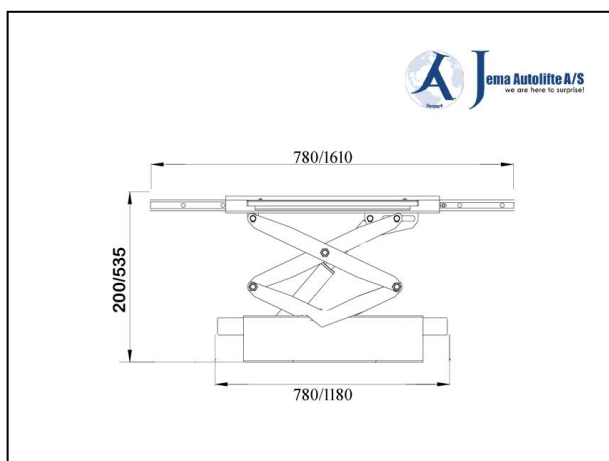

LINE ONNECTION:

Connect the electrical and oil line according to the electric wiring diagram and oil line connection



To avoid the unexpected lift closure due to mechanical safety device release, insert wooden pieces in the inner part of the base frame.

Pay attention not to work under the lift until the hydraulic system has not been completely filled with hydraulic oil.



Electrical routine connection:

Connect according to the electric connection.

Skilled personnel only are allowed to perform the operations shown below.

- Open the control box front cover

-Connection of power supply/Electric motor wire connection: please connect it according to electrical drawing.

Connection of up limit switch (SQ1)/ lower limit switch (SQ2)/ Anti-breaking rope insurance limit switch (SQ3 & SQ4 & SQ5 & SQ6): For detail connection, please see the electrical drawing.



Hydraulic hoses connection

Connect the hydraulic hoses as oil pipe connection drawing.

Only skilled and authorized personnel can operate.

Be careful about the connection of the oil hoses to protect the hoses from dust and impurities.

Add oil and check the order of phase.



After installing lift as Picture 4 required and connecting the hydraulic circuit, electrical circuit and air loop, operate it as following:

-Open the hydraulic oil tank, add 18L of hydraulic oil into the oil tank, the hydraulic oil is provided by the user.



Make sure the hydraulic oil is clean, to prevent any impurity into the oil line, if to lead the digest of the oil line and the solenoid valve will be easy to get broken.

-Turn on the power, clicking “UP” button, and to check whether the motor turns clockwise (looking downward), if not turn off the power, then change the phase of the motor.



When turn on power, there is high voltage in the control box, only authorized person can operate.

Main machine adjustment

-Press “UP” button SB1, to lift platforms to about 1000 mm.

-Press “DOWN” button SB2, and verify the safety instruction. Air cylinder (Picture 16) and solenoid air valve (Picture 17) will work, and the platforms will go up a little then begin to lower. Until they lower to around 300mm height to reach the lower limit switch (Picture 19), then the platforms stop. The operator is needed to release "DOWN" button SB2 and then press the "LOCK SEC. DOWN" button, then the lift can go on lower to the lowest position.



Picture 15(descent valve)

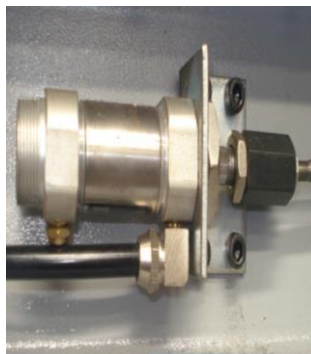

Picture 16 (air cylinder)



Picture 17(solenoid air valve)



Picture 18 (up limit switch)



Picture 19 (Lower limit switch)

Rolling jack adjustment

If equipped with manual rolling jack,

- Press the handle of manual pump, to lift the platform to approximate 300 mm
- Unfasten the handle to lift the safety rod of rolling jack, to lower the jack.

If equipped with pneumatic rolling jack,

- Press the pneumatic switch on the pneumatic rolling jack; lift the platform to approximate 300 mm.
- Press the other side of pneumatic lift the safety rod of rolling jack, to lower the rolling jack.
- Press the other side of pneumatic pump, verify the insurance instruction.

Anchor bolts installation

- Fix the lift to the concrete base with 16 anchor bolts using a percussion drill into 120 mm.
- At first, no expansion bolts are installed.

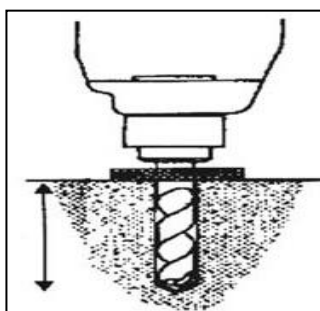

Picture 19

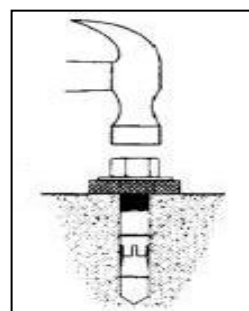

Picture 20

Level adjustment

- Adjust the level of the two front turntables (optional part) and the slide plates on both sides at back.

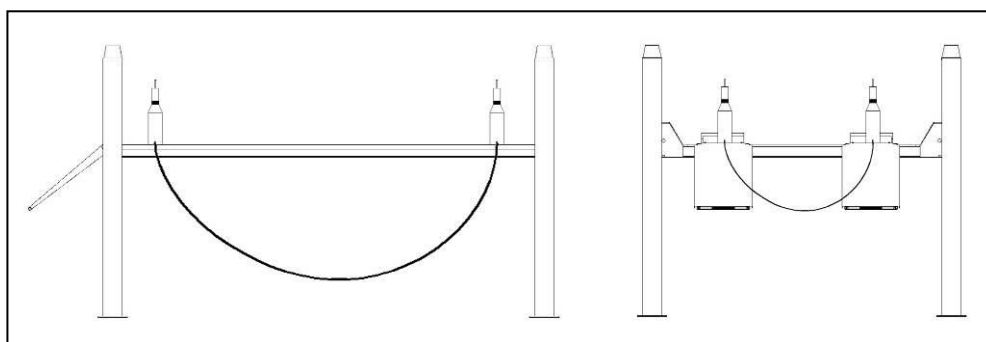

Picture 21

Insurance level adjustment:

- If the unparallel of the basement lead to the unparallel of the platform, can adjust the height of the safety rod.
- Lift the platform to approximately 100 mm; then press “DOWN” button to let the insurance go into the hole of insurance rod.

Steel cable adjustment

- Lift the platform to about 1000 mm.
- Observe the horizontal and adjust the nut that at the end of the steel cable line.
- Fix the steel cable bolts after level adjustment.

No load of main machine test

- Turn on the "MAIN SWITCH" QS.
- Press "UP" button SB1, the platforms will go up.
- Press "DOWN" button SB2, the platforms will go up a little then go down.
- To make sure the platforms are placidity, and the locking is secure, and to make sure no any oil leakage.

Loading test of main machine:

- Drive the vehicle which weight doesn't exceed maximum lifting weight of the platform, and then the driver leaves the vehicle.
- Turn on the "MAIN SWITCH" QS.
- Press "UP" button SB1, platforms will go up and the operator should pay attention to the synchronization and placidity of the lifting.
- Check and ensure the lift has no special noise.
- Press "DOWN" button SB2, the platforms will go up a little then go down.
- Press "DOWN" button, for insurance locking.
- Check and ensure the lift is placidity, and the locking is secure, and to make sure no any oil leakage.

When testing the lift, no person or other things are allowed to stand or be put near the two sides and beneath the machine. If any abnormal is found, press button "SB0" to stop it timely. After clearing obstacles, do the test again.



Only the skilled and trained personnel are allowed to perform the operations. Check proceedings as following.

Operation Notices:

- Clear obstacles around before operation.
- During lifting or lowering, no person is allowed to stand near the two sides and beneath the machine, and no person is allowed to be on the two platforms.
- Avoid lifting over heavy vehicles or other things.
- When lifting vehicle, the hand brake lever of the vehicle should be pulled, and the slide resistant triangle woods should be used.
- Pay attention to the synchronization of the lifting and lowering. If any abnormal is found, stop the machine timely, check and remove the trouble.
- When locking the main machine, the two platforms should be kept at the same height.
- When the equipment has not used for a long time or over night, the machine should be lowered to the lowest position on ground, and remove vehicle, and cut off power supply.

Instructions on electric operation (see the operation panel picture 22)

Turn the selector switch on the control panel to the “MAIN LIFT” position.

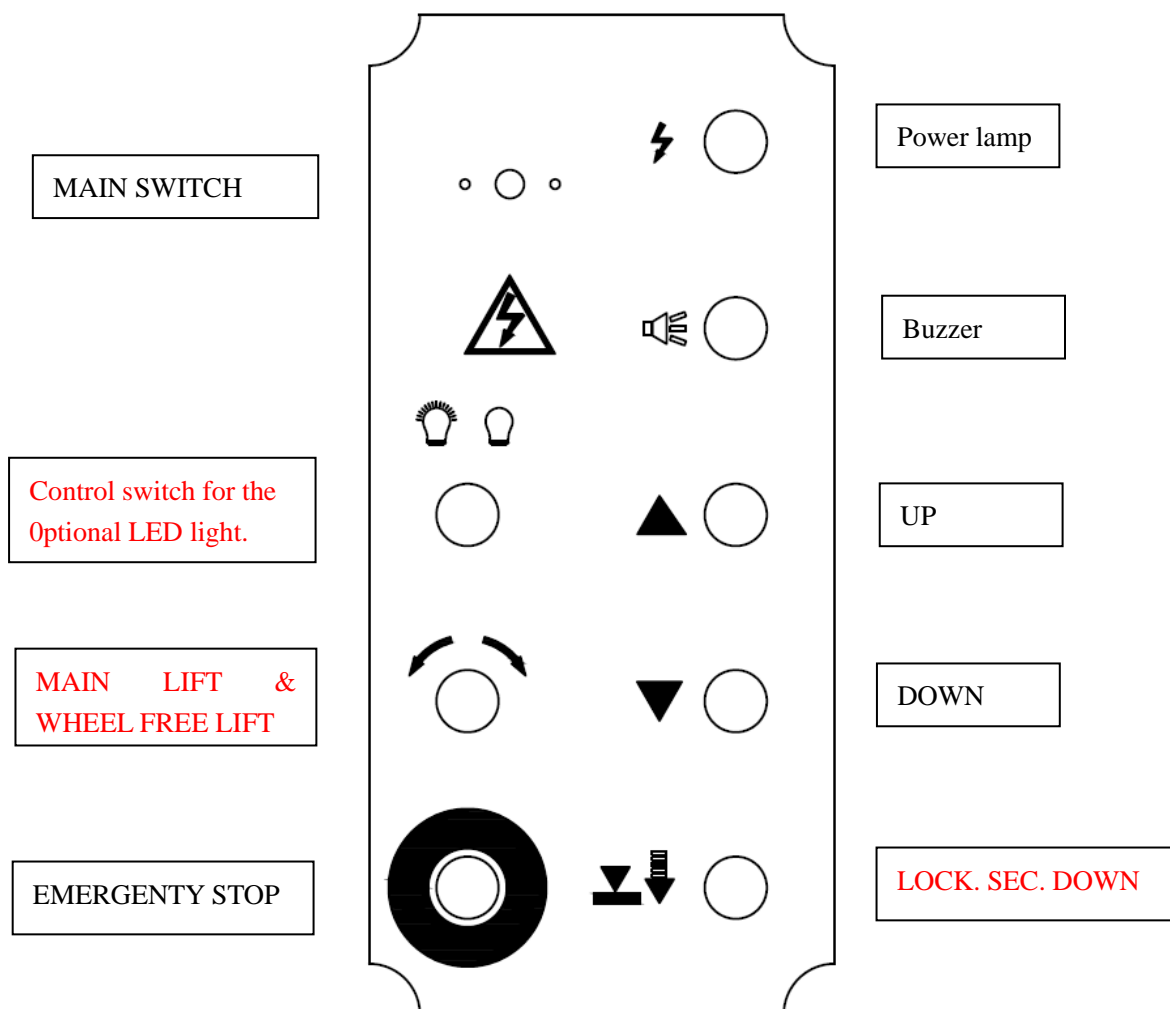

Picture 22

LIFTING:

-Press “**UP**” button SB1, oil pump works, and the platform will go up. And machine will stop lifting when touch the up-limit switch.

-Release “**UP**” button SB1, oil pump stops working and the platforms stop lifting immediately.

LOWERING:

-Press “**DOWN**” button SB2, the platforms will go up a little then go down. Buzzer rings during the whole lowering process.

-Release “**DOWN**” button SB2, the platforms will stop lowering.

-When the platforms lower to about 300mm height to reach the lower limit switch, the platforms will stop lowering. The operator needs to release "DOWN" button SB2 and then press "LOCK SEC. DOWN" button, the lift can lower to the lowest position.

EMERGENCY STOP:

-Press “**EMERGENCY STOP**” button SB0, to cut off all the operation circuit when machine is abnormal.

LOCK:

-When press "LOCK SEC. DOWN" button when the platforms are higher than 300mm, the lift will lock or go down a little to lock.

Sub machine Oil make-up adjustment

1 Open the stop valve ‘H’ ‘I’

2 Press “**UP**” button let the platform going up to the height place.

3 Switch off the valve ‘H’ and ‘I’, press ‘**DOWN**’ button; the platform goes down to the ground.

4 Repeat the operation as above for 3~4 times.

5 Press ‘**UP**’ button let the platform going up to about 300mm height. If the two platforms not at the same level, the left platform is a little lower (P1), turn on ‘the oil make-up valve I’. Otherwise, turn on ‘the oil make-up valve H’

6 Click the button “**UP**”, and then the single side of platform is lifted alone. After the two platforms both have the same height, close the oil make-up stop valve “H” or “I”, “the oil adjustment process comes to the end.

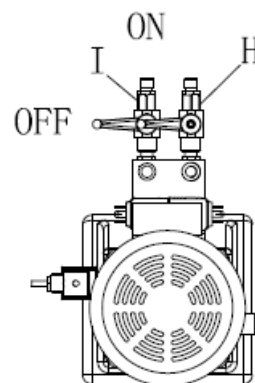

Only authorized person can operate, do alignment only for alignment model after the platforms are locked.

Lifting of rolling jack:**Manual or pneumatic rolling jack:**

Press rolling jack manual hand or pneumatic switch, to drive the rolling jack to go up.

Lowering of rolling jack:**Manual or pneumatic rolling jack:**

Loosen the oil-back valve of manual pump or another side of pneumatic pump switch and lift the insurance of the rolling jack at the same time, jack begins to lower.

Locking of rolling jack:

-Only press manual pump oil-back valve or pneumatic pump switch until the jack's insurance is engaged.

**EMERGENCY MANUAL OPERATION FOR LOWERING (POWER FAILURE):**

When lowering through manual operation, one should observe the condition of platform at any time, because there are vehicles on the platforms. If there is something abnormal, screw down oil loop valve immediately.

The process of manual operation:

If the lift is not locked, please apply the following procedure!

-Switch off the power button (to avoid abruptly incoming electricity). Then find the electromagnetic valve A for lowering.

-Loosen manual oil loop stud at the end of lowering electromagnetic valve core, then the platforms begin to lower.

-After the machine has been lowered, screw down manual oil loop stud timely, then the process of manual lowering comes to an end.

**Chapter 7 MAINTENANCE AND CARE****The maintenance and care of the lift must be operated by skilled person.**

-The upper and lower sliding blocks must be cleared of foreign objects and must be kept clean and lubricated.

-All bearings and hinges on this machine must be lubricated once a month.

-The parts for alignment should be lubricated yearly (for alignment model).

-The hydraulic oil must be replaced one time each year. The oil level should always be kept at upper limit position.

-Check the steel cable line every three months and if there is something wrong, stop using, and tell the manufacture.

-The integration of the pneumatic system with an air treatment unit is suggested.

**When change hydraulic oil, put machines to the lowest position, have the oil tank empty, when add new oil, should have the oil cleaned.**

-If equipped with rolling jack, to check the liability of the switch.

Skilled personnel only are allowed to perform the operations.

Failure	Cause	Troubleshooting
The motor does not work when press UP button.	① Connection of power supply wires or zero wire is not correct.	Check and correct wire connection.
	② The AC contactor in the circuit of the motor does not pick up.	If the motor operates when forcing the contactor down with an isolation rod, check the control circuit. If the voltage at two ends of the contactor coil is normal, replace the contactor.
	③ The up limit switch is not closed.	Short-circuit terminal 100# and 102#, which are connected with the up limit switch, and if the trouble disappears, check the limit switch, wires and adjust or replace the limit switch.
When press UP button, the motor runs, but there is no lifting movement.	① The motor turns reverse.	Change the phases of the power supply wires.
	② Lifting with light load is ok but no lifting with heavy load.	The setting safe pressure of the overflow valve need to be increased by turning the set knob clockwise slightly. The spool of the lowering descent solenoid valve is stuck by dirt. Clean the spool.
	③ The amount of hydraulic oil is not enough.	Add hydraulic oil.
When press "DOWN" button, the machine is not lowered.	① The safety pawl is not work properly.	The air pressure is not enough, or the safety pawl is stuck.
	② The solenoid air valve does not work.	If the solenoid air valve is energized, but does not open the air loop, check or replace the solenoid air valve.
	③ The descent valve is energized but does not work.	Check the plug and coil of the lowering descent valve and check the right turn tightness of its end copper nut and so on.
	④ The hydraulic oil has too high viscosity or frozen, deteriorated (in Winter).	Replace with 20# hydraulic oil in accordance with the instruction book.
The machine lowers extremely slowly under normal loads.	① The "antiknock valve" for preventing oil pipe burst is blocked.	Remove or close air supply pipe and thus lock the safety pawl of the machine without lifting of the safety pawl. Remove the "antiknock valve" from the oil supply hole at the bottom of the oil cylinder and clean the "antiknock valve".
	② Oil leakage on oil pipe or at its fitting.	Tighten oil pipe fittings or replace oil seals and then make-up oil and adjust levelness.
	③ The base or the machine is twisted.	Adjust again the levelness of the machine, and fill or pad the base.

Table 2

Hydraulic schematic diagram

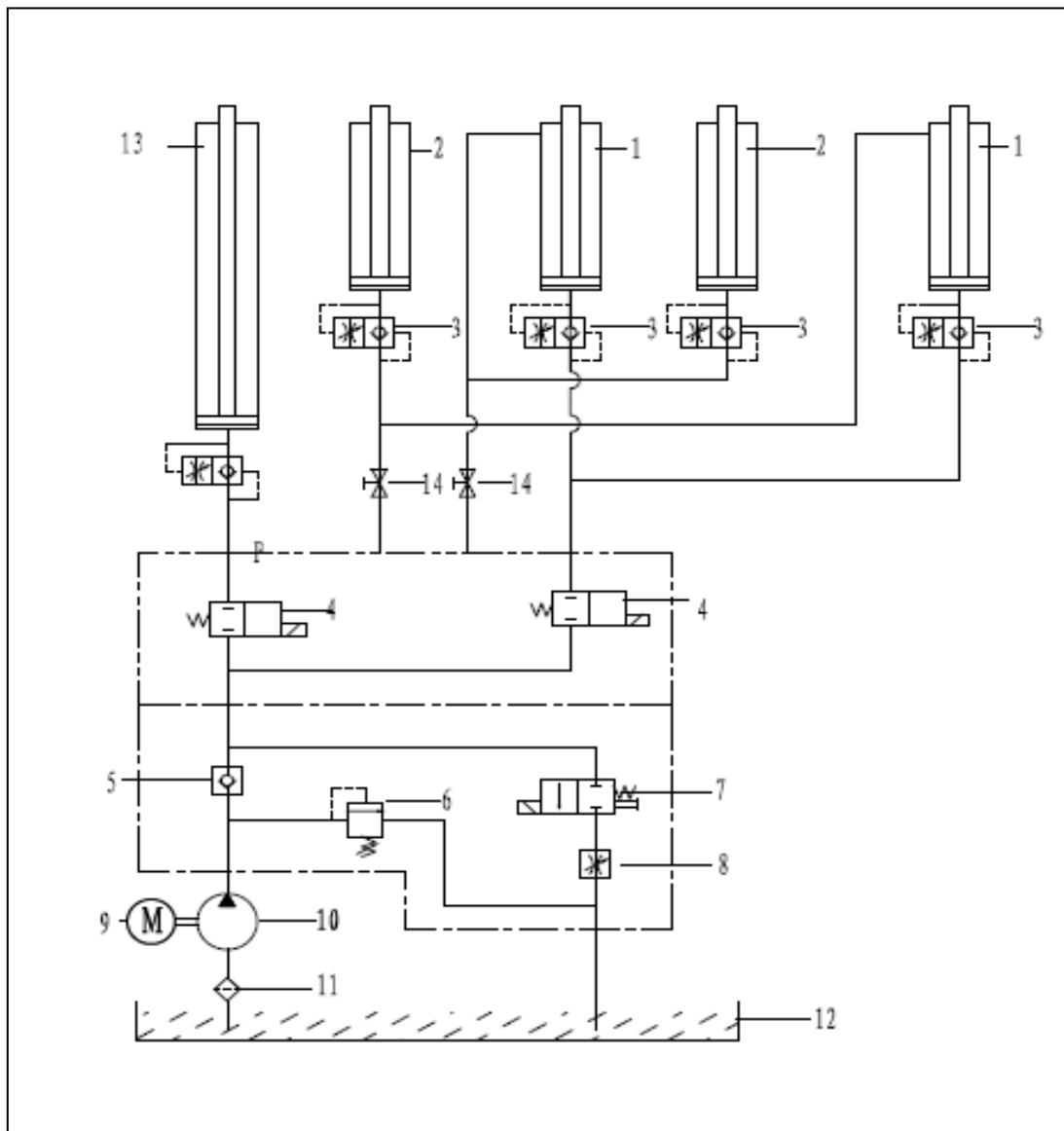

- | | |
|--------------------------------|---|
| 1 main cylinder | 8 Overflow control valve |
| 2 Sub cylinder | 9 gear pump |
| 3 antiknock valve | 10 pump motor |
| 4 Mending balance valve | 11 filter |
| 5 check valve | 12 oil tank |
| 6 overflow valve | 13 Main cylinder of main machine |
| 7 descent valve | 14 Stop valve |

Oil pipe connection diagram

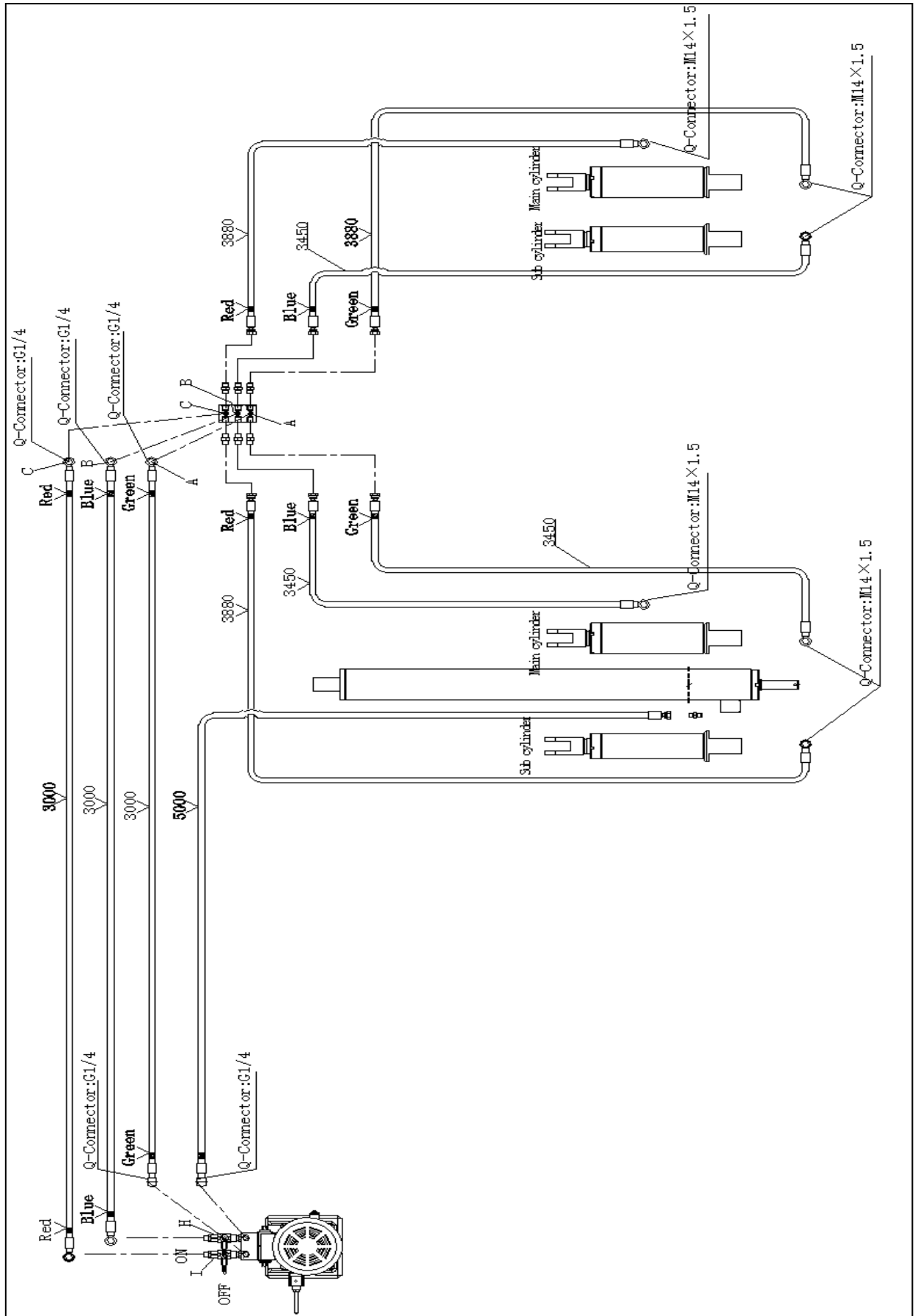

Circuit diagram

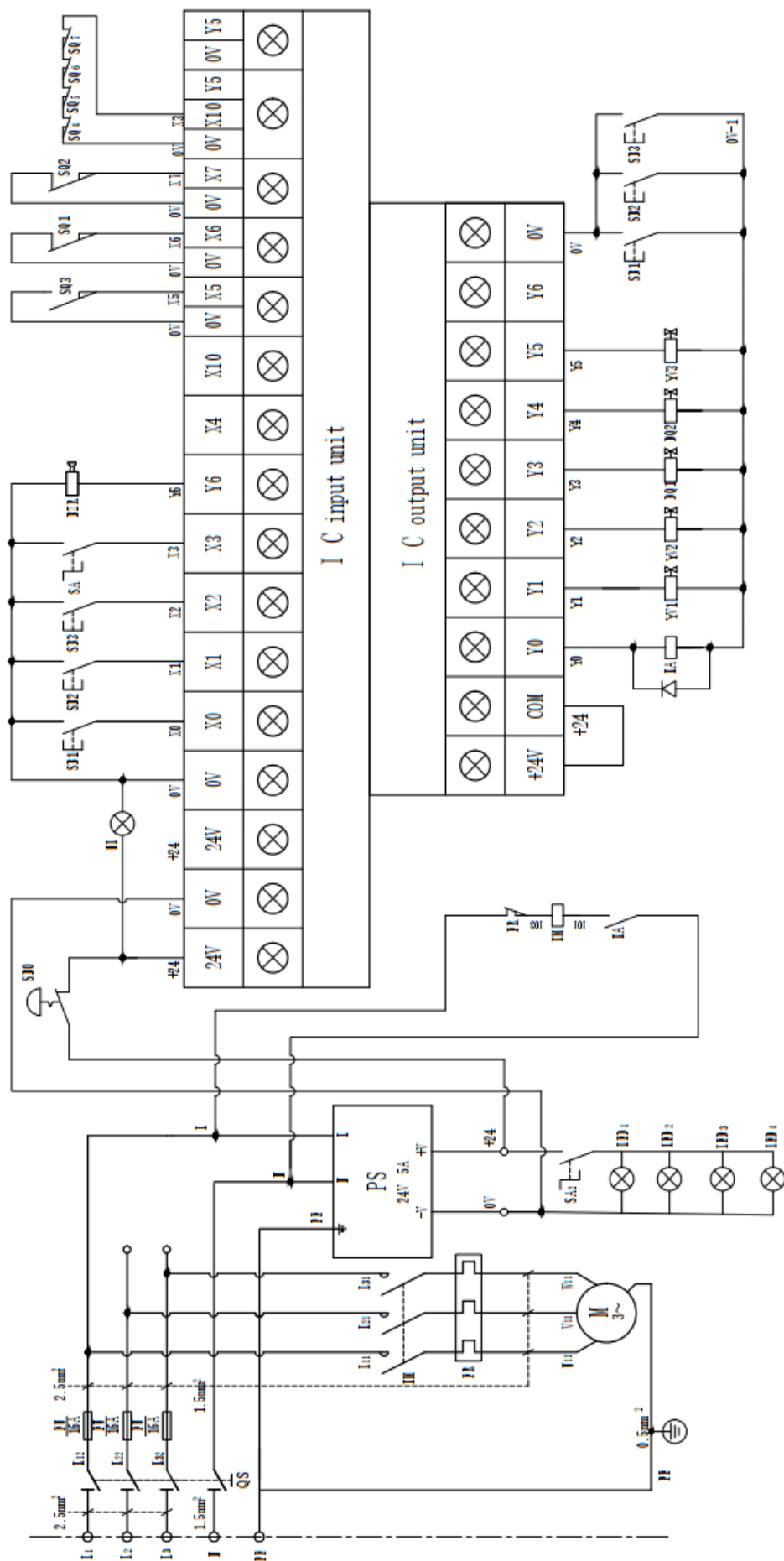



No. 6038

EC Type-Examination Certificate

(Fm 210-017, Rev.10)



For the requirements of the Machinery Directive 2006/42/EC

For Annex IV machinery

Certificate No.: CE-C-0612-17-88-14-5A
Date of first issue: 2017.07.07
Next review due before: 2021.07.17

NAME AND ADDRESS OF THE MANUFACTURER: - Italy

PRODUCT DESCRIPTION/ TYPE AND MODEL: Hydraulic Automobile Lift
 GT-FPA 5.5, capacity 5500kg, four post vehicle lift with wheel alignment platform

APPLICABLE STANDARDS: EN 1493:2010 Vehicle Lifts
 EN 60204-1:2006/AC:2010 Safety of machinery - Electrical equipment of machines - Part1: General requirements
 EN ISO 12100:2010 Safety of machinery - General principles for design - Risk assessment and risk reduction

TECHNICAL FILE REF. NO.: TF-C-0612-17-88-14-5A

A COPY IS AVAILABLE FROM: CCQS UK Ltd., 5 Harbour Exchange Square London, E14 9GE

The technical file, accompanying documentation and the equipment which they describe have been found to be in compliance with the requirements of the Machinery Directive 2006/42/EC.

The responsible person defined above has responsibility for ensuring that all future serial manufacture of the machinery conforms to the sample submitted for EC type-examination referenced above.

Any changes to the design of the machinery certified here must be advised to CCQS UK Ltd. for re-assessment.

A CE marking should not be fixed to the equipment until the requirements of all relevant directives have been met.

Approved by: JY. Liu - Managing Director 

Date: 2017-07-07

Appointed by UK Government
 as a Notified Body
 for CE Marking No. 1105

CCQS UK Ltd.
 5 Harbour Exchange Square
 London, E14 9GE

Tel: +44(0)20 7868 1509
 Email: info@ccqs.co.uk

If in any doubt about the integrity of this certificate,
 please verify it on our website at
<http://www.ccqs.co.uk>

