



2-Post-Lift-hydraulic-lift

2.35 HD FLEX - H480.12
2.40 HD FLEX - H480.12
2.45 HD FLEX - H495.12
2.55 HD FLEX - H458.12
2.55 HD G FLEX - H458.12
2.65 HD FLEX - H458.12
2.70 HD FLEX - H458.12



Original Manual

Cover

Design by: Consul Werkstattausrüstung GmbH · Daimlerstraße 1 · D-58553 Halver
Tel. (02353) 7009-0 · Fax (02353) 7009-80 · E-Mail: info@consul-gmbh.com

Version 08.2020

Documentation-Data:

Lift	Type	2.35 HD FLEX (H480.12) 2.40 HD FLEX (H480.12) 2.45 HD FLEX (H495.12) 2.55 HD FLEX (H458.12) 2.55 HD G FLEX (H458.12) 2.65 HD FLEX (H458.12) 2.70 HD FLEX (H458.12)
Original Version		07.2016
Modification:		edit BGG 945 in DGUV G 308-002 (02.01.2017) edit symbol (Protection of the Environment), schematic drawing, transport lock and electric diagram, foundation, description of main board (20.01.2017) edit spare parts lists (27.01.2017) edit spare parts lists (07.02.2017) edit spare parts lists (27.04.2017) add Manual unlocking (03.08.2017) 2.45 HD FLEX added (30.07.2018) 2.70 HD FLEX added (26.03.2019) Spare part list control (27.04.2020) Control 697797 Hydraulic unit (704924) 08.2020 Adjustment safety instructions and practical using (27.10.2022)

Table of Contents

WORKS CERTIFICATE	5
Confirmation in accordance with §5 section 4 of the Accident Prevention Regulations for "Electrical Appliances and Equipment" (BGV A4).....	6
Notification of Damages in Transport.....	8
EC-Declaration of Conformity	9
PACKING, TRANSPORT AND STORAGE.....	10
Work Place Area and Safety Area	11
Safety Instructions	12
Practical Safety Instructions and Signs:.....	15
Power supply	19
Description of the Manual Sticker	20
Delivery and Installation Requirements.....	21
Standard foundations, fastening Material & Current connection	23
The most important labelling for the new concrete standard B 4710-1	24
Concrete strength classes	24
Conventional applications	26
Safety devices	26
Practical operation using the lifts	27
Lift testing	28
Disposal of the lift	28
Installation – Service checklist.....	29
Product description	31
Foundation.....	32
Lift system base anchoring for lifts (up to 4.5 to)	33
Foundations for lifts (over 4.5 to)	35
Foundation work for lifts (over 4.5 to)	36
Assembly and commissioning.....	37
Description of the hydraulics.....	38
Basic setting	38
Attitude.....	38
Instruction leaflet H480.10 / H458.10 / H495.10	39
Transport lock H480.10.....	40
Schematic drawing 2.35 HD Flex H480.12-54778.6	47
Schematic drawing 2.40 HD Flex H480.12-53832.2	48
Schematic drawing 2.45 HD Flex H495.12-58800.4	49
Schematic drawing 2.55 HD Flex H458.12-53917.1	50
Schematic drawing 2.55 HD G Flex H458.12-57210.7	51
Schematic drawing 2.65 HD Flex 54779.4.....	52
Schematic drawing 2.70 HD Flex 59045.5.....	53
Hydraulic drive unit (704924) with 5L-Oil Tank	55
Hydraulic drive unit (702134) with 7 Liter-Tank.....	56
Lifting cylinder 5 to (53893.4).....	58
Hydraulic diagramm.....	59
Emergency lowering	60
Hydraulic oil HLP22	61
Electric diagram	62
Electric diagram (697797).....	66
Pneumatic diagram.....	67
Pick up (raising) plate with socket.....	68
Pick up (raising) plate with socket up 4,5to.....	68

Assembly of the Lifting Arms and the Arm Locking Device	69
Cover of Locking Disc	69
Consul FixLift	70
Manual unlocking	70
Faults and causes	72
Accident prevention regulations	73
Service Manual	74
Cleaning, care and maintenance instruction	75
Spare parts lists H458.10 / H480.20 / H495.10	76
Spare Parts list until 4,5 to HD FLEX	77
Spare Parts list 537282	79
Spare Parts list carriage 538637	82
Spare parts Carriage 537878	82
Spare parts Carriage 643759 for 4,5 to	82
Spare parts Carriage 643650 for 4,5 to	82
Spare parts list 538645	84
Spare parts list 554485	84
Spare parts drawing ab 5 to HD FLEX	85
Spare parts list up 5 to HD FLEX	87
Spare part list 538843 page 1	89
Spare Parts drawing carriage 5t with settling bar 539304	90
Spare Parts Lifting carriage 5t with settling bar 539304	91
Spare Parts list 563338	93
Spare parts list 554485	93
Articulated arms	94
Spare parts list articulated arm left 512525	95
Spare parts list articulated arm right 520783	97
Spare parts list swivel arm 5,5t- 45691.3	99
Swivel arm right 520700	101
Swivel arm left 520502	103
Supply of Spare Parts	104
Informations for practising the sight –and function check	105



WORKS CERTIFICATE

Herewith it is certified that the supplied vehicle lift, according to our type description, corresponds to the title and tested construction sample. It was manufactured to the regulations of technology and can be used without alterations for its purpose to the regulations of the corresponding test regulations

Consul Werkstattausrüstung GmbH - Halver, den 02.01.2017

(Frank von der Crone)

DATASHEET

Manufacturer: Consul Werkstattausrüstung GmbH D-58553 Halver

Type: 2.35 HD FLEX (H480.12)
 2.40 HD FLEX (H480.12)
 2.45 HD FLEX (H495.12)
 2.55 HD FLEX (H458.12)
 2.55 HD G FLEX (H458.12)
 2.65 HD FLEX (H458.12)
 2.70 HD FLEX (H458.12)

Serial - No. :

Year of construction :

Day of initial operation :

Confirmation in accordance with §5 section 4 of the Accident Prevention Regulations for "Electrical Appliances and Equipment" (BGV A4)

It is herewith certified that the electrical equipment / the electrical appliances / the electrical installation of the machine or plant

Lift type:			
<input type="checkbox"/> 2.35 HD FLEX (H480.12)	<input type="checkbox"/> 2.40 HD FLEX (H480.12)	<input type="checkbox"/> 2.45 HD FLEX (H495.12)	<input type="checkbox"/> 2.35 HD FLEX (H480.12)
<input type="checkbox"/> 2.55 HD FLEX (H458.12)	<input type="checkbox"/> 2.55 HD G FLEX (H458.12)	<input type="checkbox"/> 2.65 HD FLEX (H458.12)	<input type="checkbox"/> 2.55 HD FLEX (H458.12)

Serial no. _____

corresponds to the regulations for Accident Prevention for "Electrical equipment and electrical appliances" (BGV A4)

This confirmation serves exclusively the purpose of the owner's / user's exemption from the testing of the electrical equipment / the electrical appliances / the electrical installation before its initial operational use (§5 section 1,4 of the BGV A2). This confirmation does not include any guarantees under Civil Law, nor does it serve to cover liabilities.

Manufacturer or Installer of the equipment / appliances:



Consul
Werkstattausrüstung GmbH
Daimlerstraße 1
D – 58553 Halver
Halver, 02.01.17



.....
place and date

.....
(Frank von der Crone/CEO)

Important Information!

for our lift end customers in case of
Damages in transit

Delivery

Please check the goods immediately after delivery in the presence of the carrier.
If the goods show damages of transport, the carrier must not be given a blank receipt.
If necessary, note the damage on the haulage documents.

Claim for damages:

In order to ensure a quick and unproblematic claim settlement of the damage, each damage in transit must be reported immediately to the Consul GmbH and the customer service partner after the damage has been noticed.

The notification can be made by telephone, in writing or by fax / e-mail and must contain the following:

- No. of assignment on the Consul GmbH-delivery note and date of delivery
- Type of lift and serial number
- Exact description of the damage

(If necessary, use the back side of this information sheet.)

Rectifying damages and settlement

The company Consul GmbH- can only deal with transport damages if a damage claim, as described above, has been made.

Repairs or deliveries of spare parts as well as the financial settlement of transport damages are handled by your Consul GmbH service partner.



Notification of Damages in Transport

On the lift Type: _____
Serial no.: _____
Delivered with Delivery note no.: _____
By Company: _____
Date: _____

The following damage was noticed:

- on delivery
 during unpacking

(Accurate description of the damage)

The packing was

- damaged
 not damaged

Place / Date

Customer

EC-Declaration of Conformity

Consul Werkstattausrüstung GmbH
Daimlerstr.1
D – 58553 HALVER

EC – Declaration of Conformity - For Machine Directive TÜV NORD CERT 2006/42/EC

We declare herewith that the vehicle lift of the following detail has been designed, built and installed conforming to the current basic safety and health requirements as stated in the EC – Regulations. If any alterations of the vehicle lift are made which we have not agreed to, this declaration loses its validity.

Designation of the lift: **2-Post-Lift-hydraulic-lift**

Lift type:			
<input type="checkbox"/> 2.35 HD FLEX (H480.12)	<input type="checkbox"/> 2.40 HD FLEX (H480.12)	<input type="checkbox"/> 2.45 HD FLEX (H495.12)	<input type="checkbox"/> 2.35 HD FLEX (H480.12)
<input type="checkbox"/> 2.55 HD FLEX (H458.12)	<input type="checkbox"/> 2.55 HD G FLEX (H458.12)	<input type="checkbox"/> 2.65 HD FLEX (H458.12)	<input type="checkbox"/> 2.55 HD FLEX (H458.12)

Machine - No.: _____

Year of Construction: _____

Current EC - Regulation 2006/42/EG
Electro-magnetic compatibility: 2014/30/EU

Applied with harmonised standards: EN1493:2010
EN 60204 Teil 1:2006+A1:2009
EN55014-1:2006+A1:2009+A2:2011
EN55014-2:2015
EN61000-6-3 :2007+A1 :2011
EN ISO 12100:2010

Applied national standards and technical specification: DGUV G308-003

Technical responsible of documentation: Fa. Consul Werkstattausrüstung GmbH
58553 Halver

As the audited technical equipment cannot be delivered for immediate use, this equipment must be checked by an expert prior to initial operation. The company-trained technicians of Consul-Partner partners are experts.

Place: **Halver**

Date: **03.01.2017**



Signature: _____
Frank von der Crone
CEO

Frank von der Crone
production Manager

Consul Werkstattausrüstung GmbH - Filing

sequential no. CE:

PACKING, TRANSPORT AND STORAGE

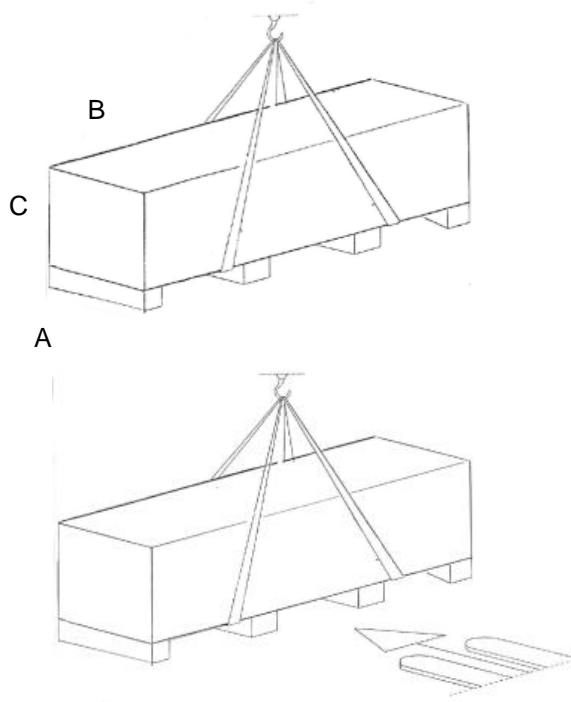

Dimensions:

Lift	A	B	C
1-Post Lift	700	3100	700
2-Post Lift	690	3100	570
4-Post Lift	970	3100	450
+ platforms			
Scissor Lift	800	5000	450
Double Scissor Lift	680	1660	790

Dimensions in mm!



max.4 pieces

Transport and Storage

The packed lift should only be lifted at the appropriate points. Gripping the lift from below with a fork-lift truck can lead to costly repairs.

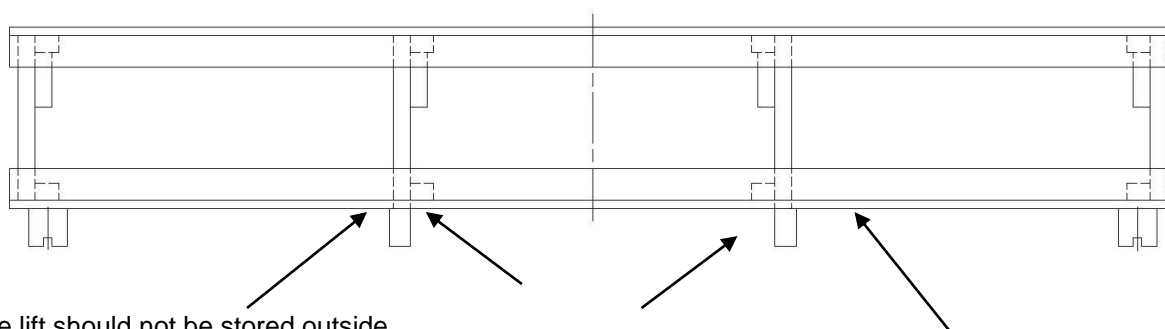

The lift should not be stored outside.

The lift should only be unpacked at its installation place.

It has to be taken care, that the column isn't knocked or dropped, otherwise the spindle might become deformed and a smooth run is not guaranteed any more.

Unpacking

When the lift and the accompanying packages are unpacked, possible damages of transport should be noted and the carrier as well as Consul GmbH should be informed immediately (see enclosed notification form). The individual parts must be laid out in such a way that nothing can be lost when the packing material is disposed of.

Work Place Area and Safety Area

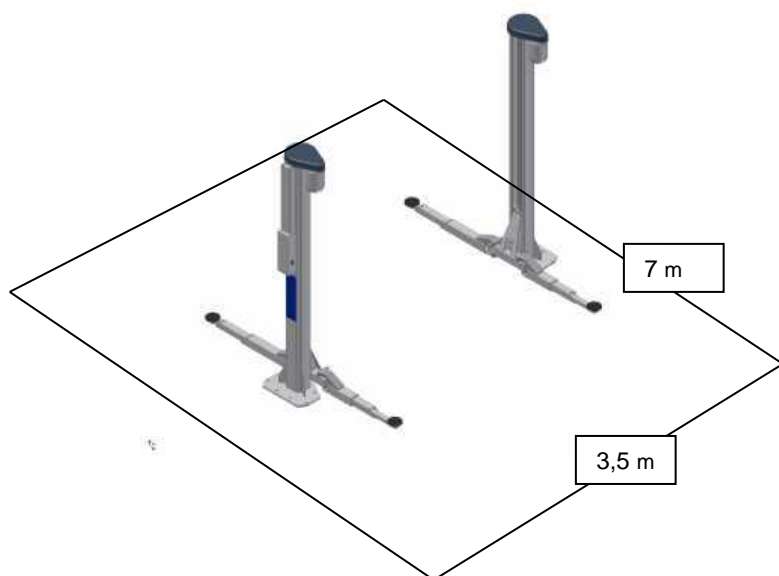

2 Post

floor space requirement

At least 1 m in front, beside and behind the car / lift

Safety Instructions



General Safety Instructions

Owner's Responsibility:

The vehicle lift is constructed and built to legal standard and further technical specifications. It therefore corresponds to current technology and guarantees the highest degree of safety in operation.

Please note, that the machine is only safe in action when all necessary measures have been met. It is the responsibility of the vehicle lift owner to plan and check that the regulations are adhered to.



The owner is responsible for the following safety aspects:

- The vehicle lift must only be used for its intended purpose
- The vehicle lift must be kept in good functioning condition and especially the safety equipment must be checked regularly to ensure that it is functioning reliably.
- Operating, maintenance and repair staff must be supplied with the necessary protective gear and it is essential that this is worn.
- The operating instructions must be kept in a legible condition and must be available where the machine is used.
- Only qualified and authorised personnel should operate, maintain and repair the machine.
- The personnel must be regularly informed about relevant operational safety and environmental protection issues and must know the operating instructions and above all the safety regulations contained therein.
- Any safety labels and warnings attached to the vehicle lift must not be removed and must be legible.





Basic Safety Measures during Normal Operation:

The vehicle lift may only be operated by authorised personnel who has received special training, knows the operating instructions and is able to adhere to them.

Before switching on the lift, the following must be checked and ensured:

- that only authorised persons are present in the working area of the lift.
- that nobody can be injured when the lift is set in motion.
- Before each use, the lift must be checked for visible damages and it must be ensured that it is only operated in good condition.
- Faults must immediately be reported to the responsible member of staff
- Before starting to operate the machine it must be checked and secured that all safety equipment is in good functioning condition.
- Inspection and maintenance intervals stipulated in the operating instructions must be observed.
- If load-carrying equipment is lifted (especially if it has been lifted for several hours), engage latch. Lifting platform is hydraulically/pneumatically depressurized.

Basic Safety Measures during Maintenance and Repair:

Before maintenance or repair work is carried out, the working area of the lift must be made inaccessible for unauthorised persons. A sign should show clearly that maintenance or repair work is in progress!



Before maintenance or repair work is carried out, unplug the power supply or, if this is not possible, switch off at the main switch and secure it with a padlock. The key to this padlock should be kept by the person who carries out the maintenance or repair work. If heavy machine parts are to be exchanged, the load bearing equipment and buffer should be appropriate and in good condition.

Any lubricants, coolants or cleaning agents which might endanger the environment, should be disposed of properly.

Electrical Work:



Repair work on the electrical system of the lift should only be carried out by a qualified electrician.

Electrical installations should be checked regularly.

Loose connections should be tightened.

Damaged leads / cables must be exchanged immediately.

Keep housing of electrical installations closed at all times. Access is only permitted to authorised persons in charge of the key / tools.

Housing of electrical installations must never be cleaned with a hose pipe.

Protection of the Environment:



During all work with and on the vehicle lift the statutory regulations regarding the avoidance of waste and proper waste disposal must be adhered to.

In particular during installation, repair and maintenance work, water contaminating materials must not be allowed to seep into the soil or into the sewage system. These include:

- grease and oils
- oils for hydraulic systems
- coolants
- detergents containing solvents

Such materials must be kept, transported and collected in suitable containers and disposed of.

Practical Safety Instructions and Signs:

The following operating instructions contain practical safety instructions in order to draw attention to any unavoidable remaining risks which might occur while the vehicle lift is in operation. Such remaining risks endanger

- people
- products
- the environment

The signs used in the operating instructions are there mainly to draw attention to the safety directions.



Danger

The sign points to danger for persons (peril of death or injuries)



Attention

This sign points to danger for machines, materials and the environment.



Danger – general sign



This sign is a reminder that the power supply to the housing must be switched off and locked so that it is secured against accidental switching on.

The most important aim of the safety instructions is to prevent injury to people.

The respective applied sign cannot replace the text of the safety instructions. The text must always be read in full.



Notice

This sign does not relate to safety but gives information which should lead to a better understanding of the machine processes.

General Safety Instructions for Vehicle Lifts:



The vehicle lift must only be used for lifting vehicles in accordance with the technical data.



Only trained personnel may operate the system.



Safety devices must not be replaced.



Necessary repair work may only be carried out by instructed customer service personnel. Unauthorised alterations of the equipment exclude any liability by the manufacturer for any resulting damages.



Work on electrical installations may only be carried out by electricians.



The vehicle lift must not be operated in environments liable to explosions.

General Vehicle Lift Safety Instructions:



An uneven distribution of load on the front and back pick-up platforms should not exceed the listed ratio of the types:

Lift at the capacity of 3.500 kg

3 : 2 and 2 : 3

Lift at the capacity of 4.000 / 5.500 / 6.500kg

3 : 1 and 1 : 3

Lift at the capacity of 7.000

3 : 2 and 2 : 3



The vehicle must be picked up at the points stipulated by the manufacturer.



The vehicle and the lift must be observed during all vertical movements.



While the lift is operated, the danger area must be kept free. Travelling on or climbing up on the lift is not permitted. Persons under the age of 18 must not operate the lift.



The safety devices must not be changed in their position or function.



Repairs should only be carried out by authorised specialists.



The statutory accident prevention rules must be adhered to.



No work must be carried out on the vehicle during vertical movements.



The nominal load shown on the lift must not be exceeded.



After a brief lifting of the vehicle it should be checked that all lifting arms are securely bolted. If necessary, the vehicle should be lowered again and by a slight swinging movement of the lifting arm the bolt should slip into place.



During assembly and dismantling of vehicle parts the shift of the centre of gravity must be taken into account



Take care when vehicles are loaded!
(other total weight and weight displacement)



If electrical welding on the vehicle or on the lift have to be done, please turn the main switch on position **O**



Danger

If the safety instructions are not observed there is a danger of injury!

Remaining Risks:



During vertical movements of the lift, no person is permitted to stand underneath a lifted vehicle or in the danger area. If this prohibition is not adhered to, there may be the danger of injury. The operator must be expressly instructed to activate the up and down switch only if no person is standing in the danger area.



The foot protection corresponds to statutory regulations, but this does not exclude all imaginable possibilities of injury, but only those which are probable according to experience. The operator must be instructed to activate the up and down switch only if no person is standing in the danger area.

Before each use, the protective device of the lift must be checked for its perfect functionality.



If a vehicle has been picked up correctly onto the lift according to instructions, there will be no danger of accidents. If, however, the vehicle has not been picked up according to instructions, there is the danger of injury. Special care must be taken with loaded vehicles or in cases of shift of centre of gravity through mounting or dismantling of heavy parts. The operator has to be instructed to check the correct pick up of the vehicle before work commences.

Power supply

Electrical connections:



Danger

A lift operated by electrical power must have a fixed device at an easily accessible place, so that the lift can be safeguarded against unauthorised use when it is no longer in legitimate use (lockable switch to power supply).

Drive power:	depends on lift type
Power supply:	3 Ph, N, PE - 400 V 50 Hz
Cable:	depends on lift type
Safety valve:	depends on lift type

Air plug:

A permanent connection for air supply which can be turned off must be installed in a place which is easily accessible from the lift.



Notice

The supply cables can be lead directly to the column head of the control column or through a power channel in the foundation directly under the base plate of the control column.



Notice

If power sockets are installed on the scissor lift or the control cabinet, these must be secured separately by the operator via an FI switch.

Description of the Manual Sticker

Picture	Description
	<p>Before using the lift, read the instruction manual carefully. Only qualified personal is permitted to operate the lift! According to the regulations for prevention of accidents, persons under the age of 18 are not permitted to operate the lift without supervision.</p>
	<p>The carrying of people is not permitted.</p> <ol style="list-style-type: none"> 1. Raise the vehicle only by the manufacturers designated lifting points. Raise the vehicle a short distance and check the lifting points again. Then raise the vehicle
	<p>During the movement of the lift, the load must be observed!</p>
	<p>During the movement of the load, no persons are in the vehicle loading area!</p>
	<p>Before lifting or lowering a vehicle check that nobody is in danger, that nothing is leaning against the vehicle and no obstacles are underneath it.</p>
	<p>Loading capacity of the Lift! Do not overload the lift!</p> <p>Lifts up to 3.5 tons and 7 tons Load distribution of the lifting platform 3: 2 or 2: 3</p> <p>Lifts over 3.5 tons Load distribution of the lifting platform 3: 1 or 1: 3</p>
<p>400 V 3ph ~ N+PE 50 Hz 16 A</p>	<p>Danger! Electrical current-carrying parts (for example main switch, contactors ,...! Electric shock when touching of energized electrical parts Electrical power consumption!</p>
	<p>1 - Please read the manual and the inspection logbook. 2 - Visual check 3 - Grease with multi purpose grease 4 - Lubricate with Oil – for this lift use grease 5 - Keep clean and greaseless! 6 - PH- neutral cleaning A - Maintenance period monthly! B - Maintenance period quarterly! C - Maintenance period half-yearly!</p>

Delivery and Installation Requirements

1. Delivery by forward company invoiced with standard freight charge: A forklift must be made available at short notice. Weight of the lifts: approx. 650 – 2700 kg, depending on lift type.

2. Delivery by truck with off - loading equipment invoiced with increased freight charge: Equipment for deposition assistance must be provided at short notice. Weight of the lifts approx. 650 – 1000 kg, depending on lift type

3. Preparations for installation

1. Prior to setting up following work must be arranged by the operator:

- ◆ Preparation of the foundation (see standard foundation).
- ◆ Laying of electrical connection to place of setting up.
- ◆ Laying of compressed air connection to place of setting up (if necessary).
- ◆ Transport of lift to place of setting up.

4. Minimum foundation requirements

The foundation surface must be flat and horizontal for all lifts. The foundation must correspond to the general guidelines for foundations (DIN 1054). For lifts installed outside, the foundation must be frost-proof. When setting up on ceiling over, the floor conditions must be certified by a structural engineer. Lifts can be anchored with anchor bolts, chemical bolts or through bolts, minimum strength 8.8 and washers.

5. Installation by Approved Consul Installer

The Consul customer Service or Consul authorised partners take on the setting up of the lift with the following criteria:

- Fixing to the floor.
- Assembly of the lift. For setting-up of the lift, additional personnel, nd/ or auxiliary lifting means must be provided at short notice.
- Electrical functional check and trial run without final mains connection that must be carried out by a local specialist.
- Permanent connection of cables between posts on EL lifts only if the cable bridge is used
- Safety acceptance with entry in the test book.
- Short instruction.

6. Average time for installation (providing the conditions above are met):

Single Post Lift - approx. 3 hours working time

2-Post-Lifts - approx. 4 hours working time (with base frame approx. 3 hours)

With the 2-Post-Lifts of the EL models series, the electrical connection cables are only assembled permanently with the use of a cable bridge (accessory). Otherwise these cables must be fixed by the operator.

4-Post-Lifts:

- Without secondary lift approx. 7 hours working time
- With secondary lift approx. 9 hours working time

Short lifts approx. 2 hours working time

Scissor lifts approx. 9 hours working time

If the lift is set up by the operator himself, the attached assembly and operating instructions must be observed. Subsequently the lift must be subjected to safety acceptance by a Consul service agent. This includes the following performances:

- ◆ Electrical functional check and trial run.
- ◆ according to corresponding test procedure
- ◆ Examination of the individual structural components.
- ◆ Entry in the check list according to corresponding test procedure.
- ◆ Short instruction.

7. Annual check (LOLER)

In addition to the check prior to the initial commissioning of the lift by our customer service section, the official regulations demand at least one safety inspection per year by experts. Our customer service will be pleased to submit you a quotation for a maintenance contract.

8. Assembly cost rates and invoicing

The performances of the customer service stated are invoiced in accordance with the respectively applicable terms and conditions of assembly, hourly rates and lump-sum travelling amounts. Fixing material is not included in the scope of delivery of lifts.

9. Guarantee

On the basis of the fact that lifts must satisfy specify safety requirements for protection of persons working of them, we draw your attention to the fact that we must tie the guarantee entitlement of the operator to the correct performed safety acceptance and entry of this into the tesbook. Always uses original CONSUL spare parts. The use of any other parts invalidates the design permit and all claims under warranty.

Standard foundations, fastening Material & Current connection

Lifts:	Model:	Manufacturer: Model description: Number of items:	Torque when anchoring :	Foundation dimensions of the individual Foundation:		Concrete base (hall floor) Foundation Characteristics:			Supply values
		For example:	Anchoring depth acc. to information provided by the anchor manufacturer	Direction length	Direction width	Min. thickness without floor covering	Concrete quality. B 4710-1	Setting depth of the anchor, in this regard, from the concrete	Warning: All fuses „inert“
2.35 HD FLEX	H480.10	Composite anchor Hilti HVA/HAS-M12x110 (12 Stück)	40 Nm	120 cm	100 cm	21 cm	C 20/25	11cm	400 V/ 50 Hz/ 3x20 A
2.40 HD FLEX 2.45 HD FLEX	H480.10 H495.10	Composite anchor Hilti HVA/HAS-M16x125 (12 Stück)	80 Nm	120 cm	100 cm	21 cm	C 20/25	11 cm	400 V/ 50 Hz/ 3x20 A
2.55 HD FLEX	H458.10	Composite anchor Hilti HVA/HAS-M16x125 (12 Stück)	80 Nm	150 cm	150 cm	21 cm	C 20/25	12,5 cm	400 V/ 50 Hz/ 3x20 A
2.55 HD FLEX	H458.10	Composite anchor Hilti HVA/HAS-M16x125 (12 Stück)	80 Nm	150 cm	150 cm	21 cm	C 20/25	12,5 cm	400 V/ 50 Hz/ 3x20 A
2.65 HD FLEX 2.70 HD FLEX	H458.10	Composite anchor Hilti HVA/HAS-M16x125 (12 Stück)	80 Nm	150 cm	150 cm	21 cm	C 20/25	12,5 cm	400 V/ 50 Hz/ 3x20 A

The setting up of the lifts is only admissible and will only be carried out if the minimum requirement on the fundamentals indicated are fulfilled at the place of setting up.

The bolt manufacturers' instructions must be followed!

Subject to change without prior notice! Date: 18.07.2016

The most important labelling for the new concrete standard B 4710-1

Exposure categories (environmental classes)

XO	No corrosion risk, no frost;
XC1	Corrosion caused by carbonisation
XC2	
XC3	
XC4	
X0	Unreinforced concrete, concrete in buildings with < 30% humidity
XC1	Concrete in buildings (residential, office), kitchen, bath, laundry room; foundations in groundwater
XC2	Interiors with high humidity, laundry room, livestock stables, indoor pools, non-pressurized ground water, water pressure height under 2 m
XC3	Water pressure height 2 to 10 m; dense concrete structures (formerly: WU)
XF1	Rain and <u>frost strain</u> for inclined (> 5 %) and vertical surfaces, all bottom views when there is frost
XF2	Concrete when there is frost and <u>deicing agent</u> (salt) for inclined (< 5%) and vertical surfaces
XF3	Rain and <u>frost strain</u> for horizontal surfaces; hydraulic structures
XF4	Concrete when there is frost and <u>deicing agent</u> (salt) for horizontal surfaces (formerly: FTB)

Concrete strength classes

The new compressive strength classes are to be approximately compared as follows:

C 8/10	B 8/B 80
C12/15	B 15/B 160
C16/20	B20 / B225

C20/25	B25
---------------------	------------



Attention!

Important installation !

First Construction only werksgeschultes personnel established by the installation and operating instructions (this voids the warranty)

Check the box contents before installation

Final insulation test must be in accordance with VDE Regulation 0100

The test regulations must be complied with

Essential information on the foundation lift consider

Foot protection check for proper height (Forced stop and beep).

Care points (axles, shafts, hydraulic cylinders, hydraulic hoses) note intervals (see Operation sign)!

Consul Werkstattausrüstung GmbH
Daimlerstr. 1
D-58553 Halver

Telefon: ++49 (0) 23 53 – 70 09 - 0
Telefax: ++49 (0) 23 53 – 1 25 15

Conventional applications

Your Consul lift has been design-tested in its basic concept, this lift offers you maximum economic efficiency and safety. It is up to you to make use of these advantages.

A prerequisite for this is correct operation, perfect maintenance and good care of the lift. Please read these operating instructions carefully. They provide you with all necessary data and show how simple it is to keep your lift ready for use at all times.

Your Consul lift is only designed to raise automobiles or vehicles whose total weight does not exceed the lift's maximum permitted load capacity and whose specified support points are within the lift's support area.

All 4 locating points have to be used.

Your Consul lift is designed to raise motor vehicles. The carrying of people is not permitted. When using the lift in lacquering plants or rooms in which a large amount of work is carried out with solvent-containing materials, pay attention to the risk of explosion. In its standard form the drive is not protected against explosion.

Safety devices

Your lift is equipped with several safety devices, to ensure workers safety, if the lift is used according to this manual.

Please take care of these safety devices, when installing the lift and check them after any case of failure.

Only trained service people are allowed to repair this lift.

Only original parts are to be used for repair. If third parts equipment is used for repair, the CE certificate of conformity will be avoided.

In accordance with the regulations regarding the operation of lifts, lift devices must be checked for their operational safety by an expert at the latest after one year (LOLER). Records must be kept of inspections.

In this respect please pay attention to ensuring that only company-trained experts, who have been instructed in the function of lifts and who are in possession of a certificate from the manufacturing company, check and accept your lift.

Deadman-Circuit:

The scissor lift is equipped with a rotary reversing switch. During the lowering or lifting process by releasing the rotary reversing switch, the lift stops immediately in the current height.

Foot protection:

in the form of the acoustic warning signal. The limit switch turns off the lift. By operation of Q1 and S1 is the same horn on and lowers stage with a further warning.

Safety valve for automatic stop during the lowering:

A throttle valve limits the lowering speed by limiting the volume velocity.

Pressure relief valve:

The valve shuts off the hydraulic power in case of overload the lift system.

Practical operation using the lifts

First of all, bring the main switch to position 'A'. By actuating the operating switch, the lift will be put into operation according to the direction of travel. After releasing the operating switch, this will automatically jump back into the 'stop' position.

The operation of the lift is only allowed for persons who have been authorised and instructed.

According to the accident prevention regulations, the independent use of the lift by persons under 18 years of age is forbidden.

It is not allowed for passengers to travel on the pick up device or in a vehicle to be lifted. See also the notes on operating the lift as well as the accident prevention regulations.

If disruptions to the lift occur, put it out of operation straight away, secure against unauthorized use and inform the Consul customer service office.

Observe the operating instruction notice on the operation panel.

Before any lifting or lowering of a vehicle, make sure that there are no persons remaining in the danger area. Do not lean items against the vehicle and do not place any items under the vehicle.

If longer work is carried out or the load-carrying equipment is lifted overnight engage latch.

Lifting platform is hydraulically/pneumatically depressurized.

Warning!

Some vehicles require pick ups which can operate at a higher level. Distance jack sets are available as an accessory (4 pieces) in order to guarantee safe lifting of a vehicle in special cases. Speak to your suppliers about this.

When using a transitional chassis when running in, the chassis must be totally lowered.

The overall vehicle weight, may **not** exceed the total loading capacity of the lift (3500kg / 4000kg / 5500kg / 6500kg), and the load distribution in 3:2 and 4000kg at 3:1.

Only original Consul accessories should be used as a means for lifting loads (model certified parts). Blocks of wood or other aids to lifting loads are prohibited due to the increased risk of accidents.

It is preferable that vehicles are (approach) driven so that their centre of gravity lies in the centre of the lift (particularly in the case of AS bearing arms).

When disassembling parts, pay attention to the distribution of the centre of gravity as the vehicle which has been picked up could crash down.

The lift is only designed to be used as a vehicle lift, other applications even if they seem practical do not form part of the intended use.

The deflection clamp for the clamping band must have enough distance from the columns so that the clamping band does not jam and become damaged. Possibly re-align the deflection clamp.

If when lifting 'whirring' noises occur, caused by the clamping band, lubricate on the back with a little all-purpose grease.

The oil supply container is to be filled up to the upper oil-level marking with **HLP22**.

The correct direction of engine rotation is checked by briefly actuating the lifting button.

The use as lifting aid for lifting heavy automotive parts, for example: Motor the expansion, etc. is prohibited. The swivel arms are equipped with automatically operating locks that unlock when lowering.

Lift testing

The examination of lifts must only take place according to the accident prevention and insurance association principles and the standards and specifications listed therein.

For example, part 2, item 5

The nature, scope and execution of the tests

Appendix 2: Information on the master data sheet in the log book

Lift testing

The sections listed above are excerpts, otherwise the corresponding test regulations is binding. The required tests are correspondingly carried out by Consul's assembly services according to the specifications. Please ask Consul's sales associates for inexpensive maintenance contracts.

Disposal of the lift

The machine can only be dismantled and disposed of by authorized technicians. The same regulations must be observed as when the system was put together. In the case if the system being scrapped, all materials must be disposed of in accordance with the relevant laws of the country where the system is installed.

The scrapping of the lift must be in documented accordance with the laws of the country in which it is installed.

Warning!

When loading / unloading, moving, installing, assembling or dismantling the machine, all of the applicable safety precautions are to be followed (safety helmets, gloves and shoes) as listed in the accident prevention regulations of the corresponding country. Moreover, safety rules must be observed when using lifts, vehicles, etc.

Installation – Service checklist

Customer adress

Service partner	Type:			
	Serial No.:			
	Year:			
	Commissioning:			
A. Before the installation.				
			O.K.	n O.K.
1.	Before the installation please check for any shipping damage (e.g. control box, head plate etc.). In case of shipping damage inform the operator (Commerce / Shipper).		<input type="checkbox"/>	<input type="checkbox"/>
2.	Check the completeness of the lift incl. Accessories.		<input type="checkbox"/>	<input type="checkbox"/>
3.	Determine the required space of lift. Note here: Ceiling height, vehicle positioning, safety distances and location of control post		<input type="checkbox"/>	<input type="checkbox"/>
4.	Test drilling For 2-post lifts one test drilling for each post and foundation check (anchor tensile force) o. foundation verification		<input type="checkbox"/>	<input type="checkbox"/>
5.	Floor levelness / descent. 2.-post: L.=max 1% max. 1% 4.-post : L.=max 0,6% max. 0,5% Scissor : L.=max 0,6% max. 0,5% Scissor AM : L.=max 0,6% max. 0,5%		<input type="checkbox"/>	<input type="checkbox"/>
6.	Energy supply on site. Electronic connection (400V / 20A gl) only made by electronic-specialist according to VDE 0100. Air: 8-10 bar with maintenance unit		<input type="checkbox"/>	<input type="checkbox"/>
B. During the installation:				
Important references before and during the installation of the 2-post lift generation				
1.	Installation only to be made by factory-trained technical staff according to standards of the Installation manual (otherwise the warranty will expire)		<input type="checkbox"/>	<input type="checkbox"/>
3.	Closing insulation check must be done according to DIN VDE-guideline 0100 – local electric specialist -		<input type="checkbox"/>	<input type="checkbox"/>
4.	Made aware of the test specification according to corresponding test regulations		<input type="checkbox"/>	<input type="checkbox"/>
5.	Implicitly observe the references for the foundation of the lift		<input type="checkbox"/>	<input type="checkbox"/>
6.	Observe mounting dimensions according to installation manual		<input type="checkbox"/>	<input type="checkbox"/>
9.	Pay close attention to the parallelism of the motor axle and spindle axle. For a correction of the head plates the two head plate screws can be loosened and retightened.		<input type="checkbox"/>	<input type="checkbox"/>
10.	Test function of the swivel arm locking mechanism. ATTENTION! When lowering the swivel-in height after installation the swivel arm locking mechanism must first be stopped functioning and then readjusted afterwards.		<input type="checkbox"/>	<input type="checkbox"/>
11.	Implicitly fill the supporting lubrication system with original spindle oil.		<input type="checkbox"/>	<input type="checkbox"/>
13.	The lift comes ex works pre-programmed and must be adjusted to the conditions on site. Check the correct height of the acoustic foot protection (forced stop and alarm sound)		<input type="checkbox"/>	<input type="checkbox"/>
14.	The alignment of the posts (outer tilting) must be observed, approx. 10 mm on post length		<input type="checkbox"/>	<input type="checkbox"/>
15.	Check upper and lower distance on the deflection bar of the cover tape (correct if necessary and grease back side of cover tape if required).		<input type="checkbox"/>	<input type="checkbox"/>
16.	Don't tighten self-tightening swivel arm safety screws approx. 1mm clearance swivel arm movement (Observe clearance between screw head and swivel arm bearing of 1-2 mm).		<input type="checkbox"/>	<input type="checkbox"/>
17.	After the first test run without load another test run with the approx. nominal load must be done. Adjust setup if necessary. Afterwards adjust the running mechanics with a vehicle of medium weight (approx. 2/3 of nominal load) and counter with counter nut.		<input type="checkbox"/>	<input type="checkbox"/>
18.	Observe maintenance points! (see lubrication and maintenance plan)		<input type="checkbox"/>	<input type="checkbox"/>



19.	Only lift with all 4 swivel arms at the valid pick-up points stated by the vehicles manufacturer.			
20.	Check all detachable connections			
21.	Repeated checking of all adjustments (e.g. security devices, end stop points, belt tension, running mechanics, brake)			
22.	Presentation and briefing of lift on function, security devices, servicing and maintenance.			
C. After the installation.				
1.	Completely fill out test book.			
2.	Extensive briefing of customer on the function of the lift,			
--	Briefing on security devices and emergency lowering,			
--	Briefing on operation and proper use of the lift (e. g. 4 arms – 4 pick-up points)			
--	Briefing on maintenance, servicing and yearly UVV-approval			
--	Name of briefed person: _____ (person in authority)			
3.	Handover of test book, installation manual and the brief instruction (with indication of attention!)			
D. Maintenance obligations of the operator 2-post (Maintenance intervals: quarterly)				
1.	Arrange yearly check according to corresponding test regulations!			
2.	Maintenance according to operation manual			
3.	The lubrication applies supporting lubrication to spindle and nuts! However this lubrication does not always suffice (e.g. thick oil due to cold). Check monthly! Manual lubrication acn help when faced with eventual rough running features.			
4.	Grease swivel arm mounting bolts.			
5.	Check belt tension, retighten if necessary.			
6.	Check castor brake, retighten if necessary.			
7.	Regularly check safety devices (e.g. swivel arm locking mechanism).			
<p>A briefing on function, operation, servicing and the safety devices of the lift has taken place. A briefing on the MAINTENANCE OBLIGATIONS OF THE OPERATOR has also taken place. The operator has been extensively briefed and has assured himself of the faultless function of the lift. Indication of attention of the extensive operation manual! Without properly filling out this brief instruction the warranty will expire!</p>				
Notes:				

Date	Signature	Name in block letters operator	Stamp operator:	
Date	Signature	Name in block letters briefed pers		
Date	Signature	Name in block letters briefed pers	Stamp service partner:	
Date	Signature	Name of installer / service partner		

Product description

These lifts essentially consist of the operating column and side columns. Hydraulic cylinders and jack lifts with the pick up device are found on both pillars.

The drive consists of a three-phase motor 2.5 kW, 220/400 V, 50Hz, which drives a gear pump. The flow of oil goes from the pump, secured through a pressure relief valve to the hydraulic cylinders. By actuating the push-button 'lift', the motor is switched on, allowing the hydraulic cylinders in the lifting columns to put the jack lifts in motion.

By actuating the push-button 'lower', the solenoid valve is unlocked and the oil can flow back via the lowering valve to the tank.

The hydraulic cylinders are connected with the jack lifts. Depending on the control of the drive, the jack lifts can move upwards or downwards, and thus perform raising or lowering actions. The jack lifts travel on maintenance-free ball bearing rollers in the column.

The even running of the lifting carriages is ensured via an electronic synchronizing governor. Any lack of synchronization in the lifting carriages (eg, because of an uneven load, lack of lubrication, etc) is regulated by the synchronization control to within a distance of approximately 10 mm. The advancing lifting carriage is briefly stopped until the slower carriage reaches the same height. This check may be observed several times in the course of the lift.

Using the operating switch on the control box, the lifting motion is switched on according to the motion symbols and is switched off at the upper and lower end position via a programmable electronic unit. For safety reasons, an automatic stop is programmed in the downward movement with a height of 200 mm (top edge of base - lower edge of load pick up device). By releasing and re-actuating the operating switch, the jack lifts travel further downwards accompanied by an audible signal.

The operating switch automatically goes back to its original position after being released and it stops the movement of the lift at every position of the pick up device. The lift is equipped with a number of passive safety devices and active safety devices.

There are catching bars located in all columns. You will also find parking bars every 80mm distance. The pneumatic driven locking device (elasticity) will be unlocked again with every movement up or down of the lift.

The swivel arm locking device, which after a short distance, locks the bearing arms from their basic position into their swivel motion in order to prevent the load pick up device slipping from the pick up points onto the raised vehicle.

The thermal sensor in the drive motor switches off the lift in case of thermal overload and which releases the lift for operation after cooling down again.

When the lifts over 3500 kgs is only a max. Load distribution of 3:1 allowed

The exception is the 2.70 HD Flex with 7.000 kgs load capacity, here is a load distribution of 3:2 allowed

With the symmetrical two-column lifts, all pivot arms are the same length and the vehicle to be raised is placed between the columns, centrally, in the approach direction.

The vehicle to be lifted is placed such that the front door hinges are located in the area of the lifting columns, in order to gain a large door opening angle. (where possible, the vehicle's centre of gravity should form the centre of the lift.).

Foundation

As the Consul H480.10 have been designed as 'underframe-free' lifts, the substrate and/or foundation is of great importance. The transfer of forces caused by the lifted load and the own weight of the lifting columns, is led through the composite anchor (anchors) into the foundations.

Before setting the lift up, it is imperative to be certain about the existing base (see sheet 'Base anchoring for the lift equipment corresponding test regulations).

When setting up the lift on a floor, check its load carrying capacity. For this, it is a good idea to involve a structural surveyor.

After clarifying the existing substrate, the respective attachment type has to be chosen.

The anchor depths of the composite anchor specified in the attached sheet (anchors are **not** included) must be adhered to (note information provided by the the anchor manufacturer), as otherwise, there is no adequate safety for persons working under the lift.

The correct length (L) of the of the composite anchor rod results from adding the dimension 'h' + the thickness of the scree surface and tile height + component height of the mounting plate. The drill diameter and the torque for the composite type anchors are model-specific. For this, you should follow the information provided by the anchor manufacturer.

The prerequisite for a correct setup is a flat, horizontal concrete floor (minimum C20/25, frost-proof), with appropriate load capacity.

Depending on the type of anchor, use sufficiently sized washers for the drill holes - diameter 21 ⁺¹ mm (H480.10) and 26 ⁺¹ mm (H458.10) in the base plate.

Lift system base anchoring for lifts (up to 4.5 to)

- B** Min. concrete thickness (21cm)
h Anchor anchoring depth in C20/25
s Thickness of the concrete covering up to C20/25 concrete
t Component thickness
g Length of thread
L Length of anchor
X According to the specifications of the anchor manufacturer
 Length of anchor $L = h + s + t + g$

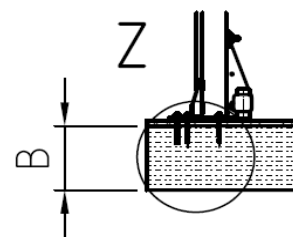

Depending on the type of anchor, use sufficiently sized washers for the drill holes-diameter 21+1mm in the base plate.

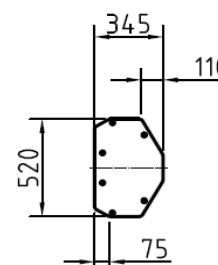

Dimension in mm

Z 1:5

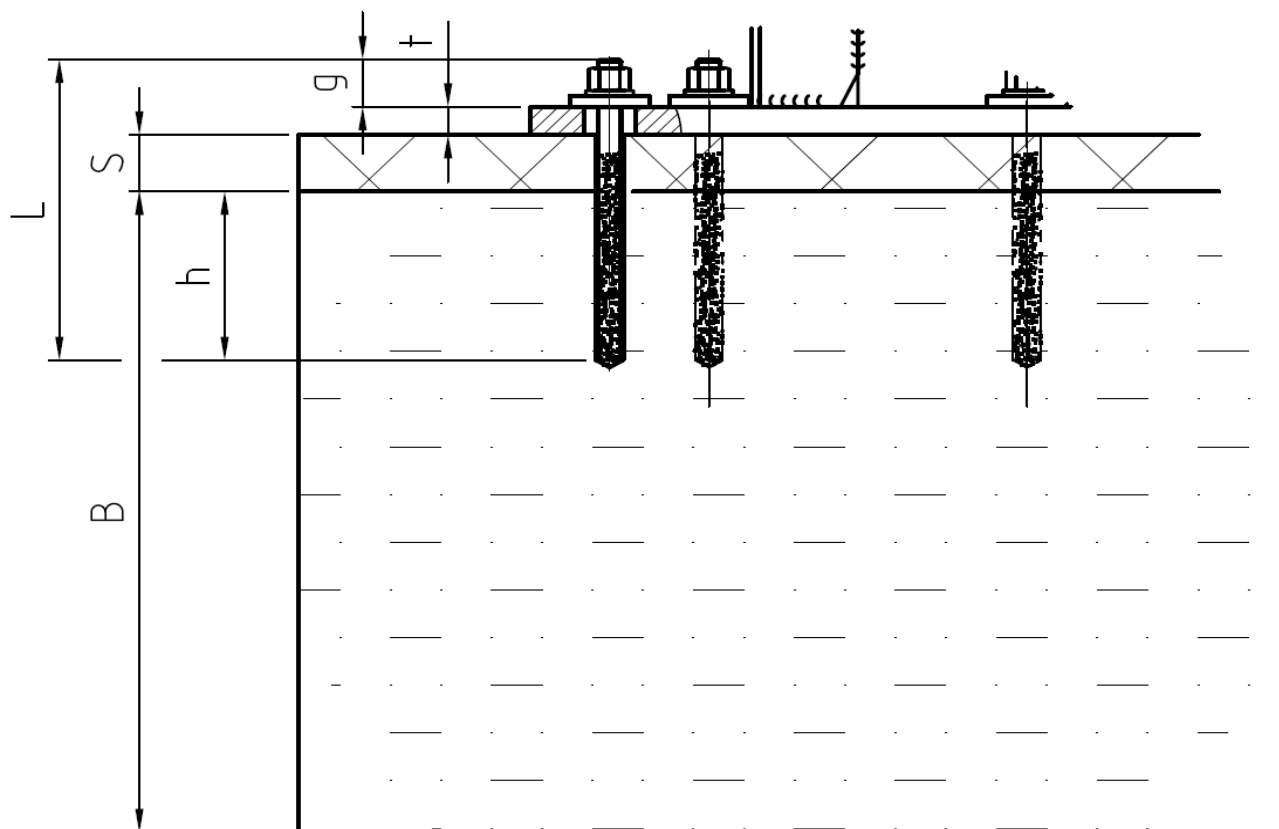

Subject to change without prior notice

Foundations for lifts (up to 4.5 to)

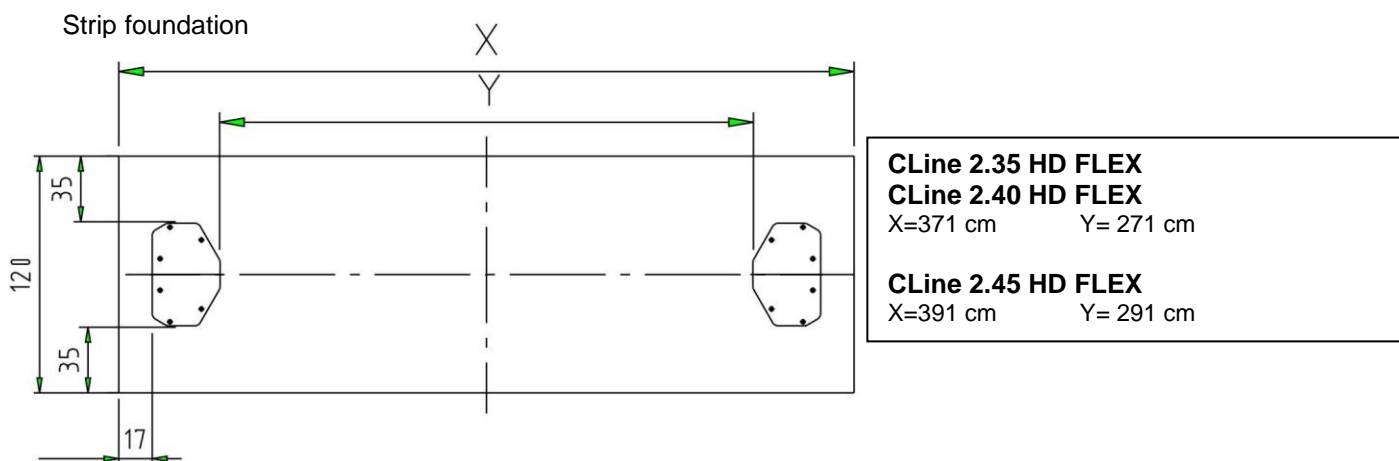
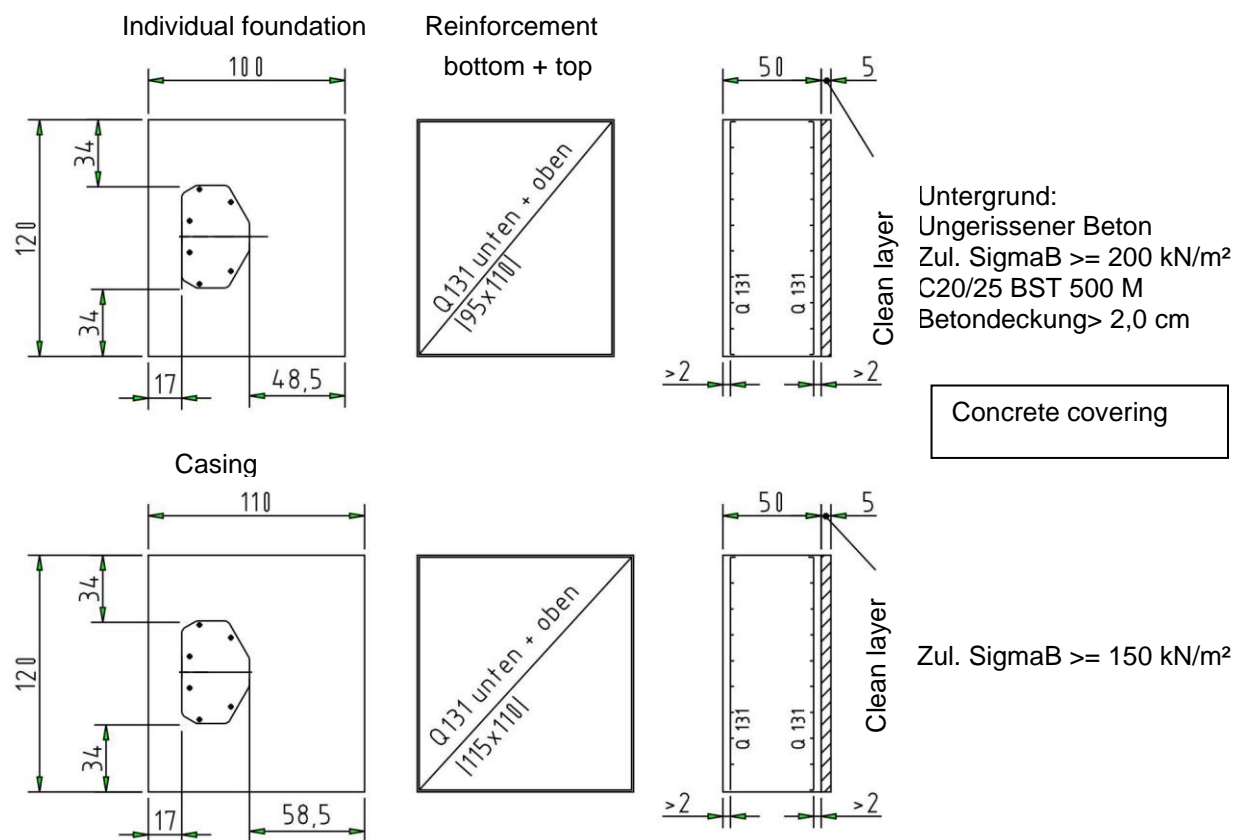

		Bottom plates C 20/25
		Thickness: $d \geq 21$ cm
necessary a_{sx}	= 2.57 cm ² /m	- lower reinforcement BST 500 M
necessary $a_{s,x,y}$	= 3.77 cm ² /m	- upper reinforcement BST 500 M
Column fixing:		
Hilti HVA/HAS-M12x110 mm for 2.35-HD-FLEX		
or Hilti HVA/HAS-M16x110 mm for 2.40/2.45-HD-FLEX		

Note: Pay attention to the prescribed assembly specifications and minimum anchorage depths as stated by the anchor manufacturer.

Individual records are required when anchoring onto existing reinforced concrete floors.

Foundations for lifts (over 4.5 to)

- B = floor thickness (21 cm)
 H = anchoring depth of dowels in C20/25
 s = thickness of ground covering til concrete C20/25
 t = thickness of component
 g = threaded length
 L = length of dowels
 X = according to indications of manufacturer
 Length of dowels: $L = h + s + t + g$

Depending on the type of anchoring, use appropriately-sized washers for 26+1 mm drill holes in the baseplate!

Subject to change without prior notice!

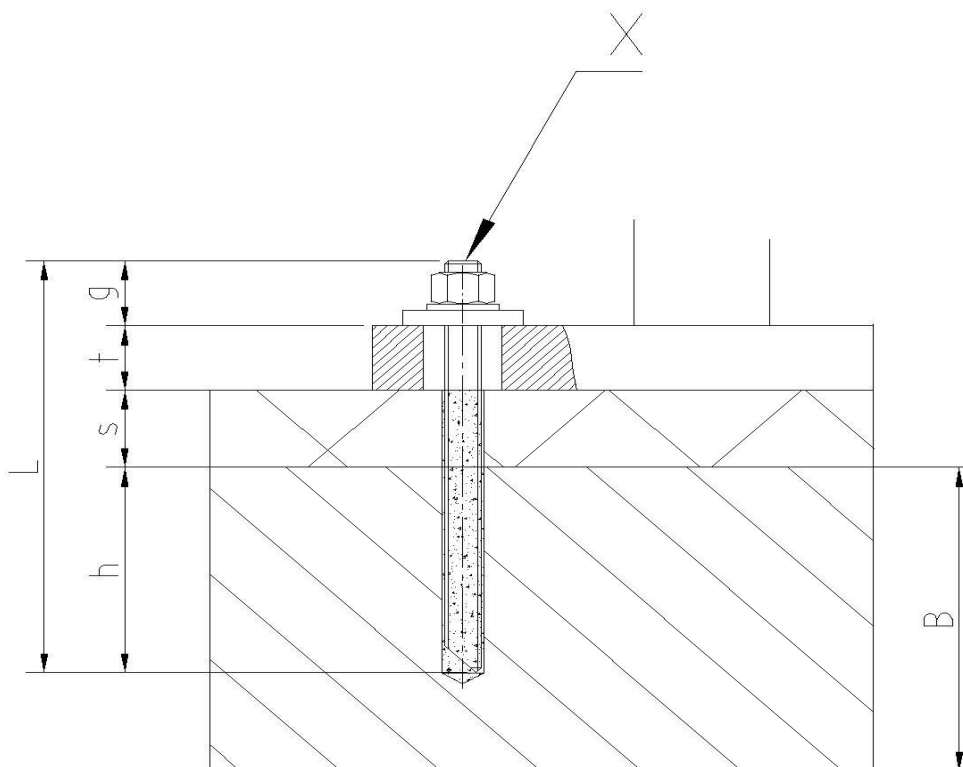
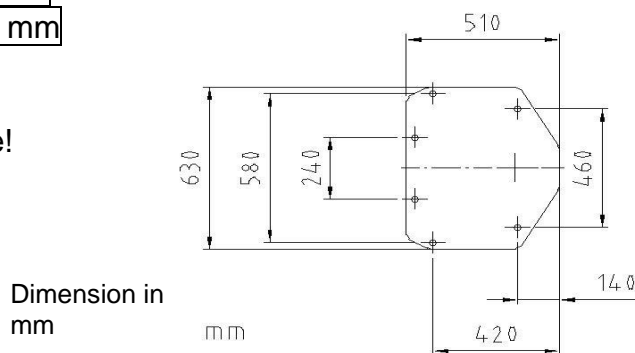

Foundation work for lifts (over 4.5 to)

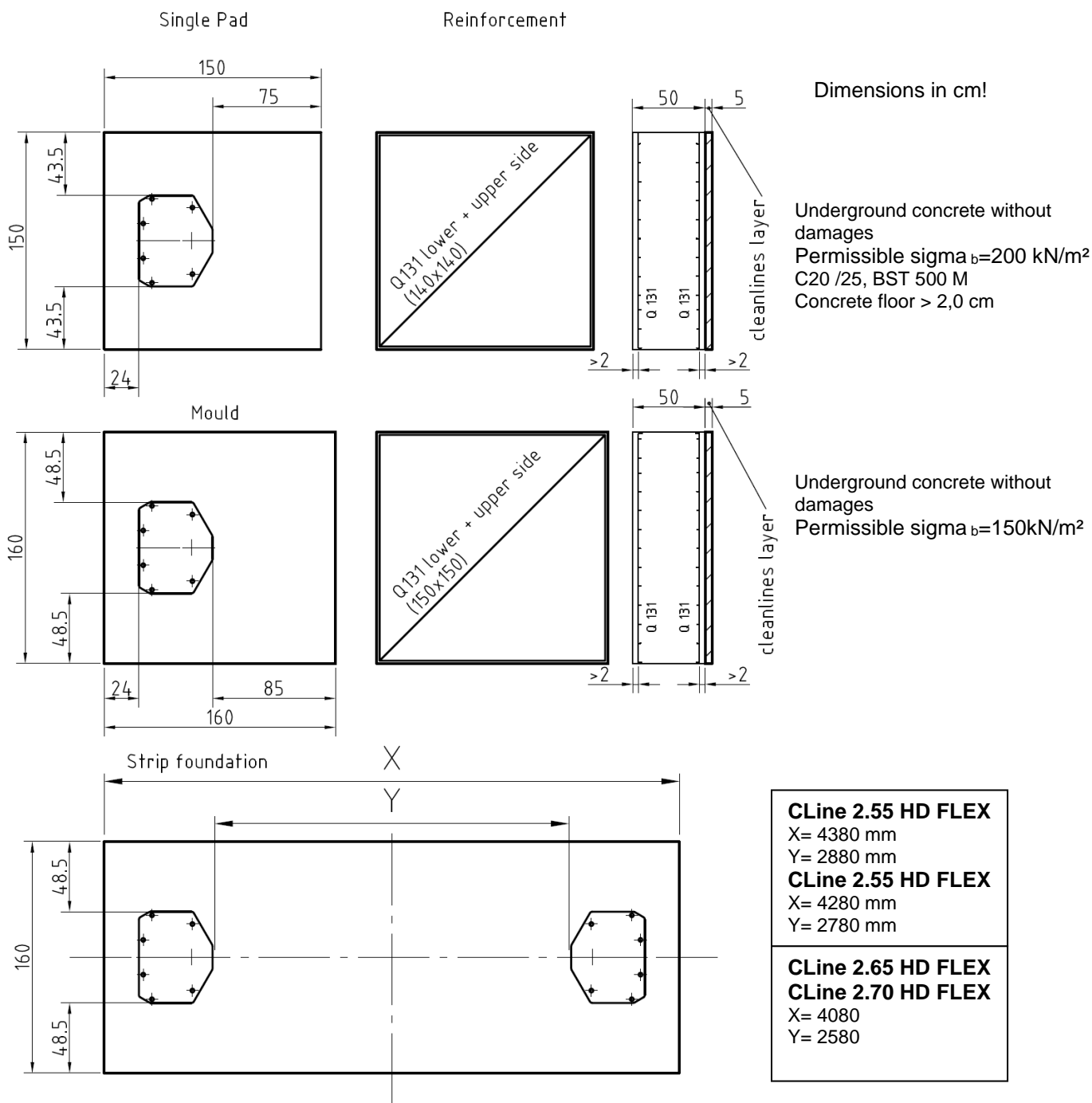

Dimensions in cm!

Underground concrete without damages
 Permissible $\sigma_b=200 \text{ kN/m}^2$
 C20 /25, BST 500 M
 Concrete floor > 2,0 cm

Underground concrete without damages
 Permissible $\sigma_b=150 \text{ kN/m}^2$

necessary a_{sx} = 2,57 cm^2/m - lower reinforcement BST 500 M
 necessary $a_{sx,y}$ = 3,77 cm^2/m - upper reinforcement BST 500 M

Column fitting: for ex. Hilti HAS M16 x 125

Important: Always follow the assembly instructions and keep to the min. anchoring depths specified by the dowel manufacturers!
 Tests on existing concrete floor are necessary for anchoring!

Assembly and commissioning

The prerequisite for a trouble-free statement is a flat and horizontal concrete floor with appropriate carrying capacity (minimum C20/25). First of all, the lifting columns are set up on their resting places. The distance dimensions of the column base plates are contained in the respective dimensioned sketches below.

According to EN1493 be an adequate safety gap of 500 mm min. must exist between the lifting columns and other limitations (wall, etc.) and/or between the raised load and the limitations.

At the first will be montage the Column in horizontal Position (Cylinder / lift truck).

Attention: instruction leaflet

Then the columns are erected and anchored at its stand in the ground. The distance dimensions of the column base plate are given in the respective dimensional drawings.

After a repeat check of the assembly situation, the floor slabs are anchored (the floor surface slabs must cover the area fully.). You will require 12 composite anchors M12 or M16(Depending on the version), which are to be selected in accordance with the information contained in the chapter 'Foundation'. The other brands can also be used which are officially permitted for concrete work. Anchors are **not** included in the scope of delivery.

The lifting columns should be perpendicular, not tilted inwards.

A slight tilt towards the outside (up to 10 mm) is required. Additional sheets must be laid underneath where necessary, between the floor and the column base, so as to make up the difference.

Warning!:

Protective earth conductors are to be tested following the initial installation, following repairs, following changes to the installation and according to the VDE-0100 specification.



When working on the hydraulics, pay attention to the cleanliness of the hydraulic elements to ensure future trouble-free operation of the lift. All work is to be done this way.

Any available protection plugs are to be removed before connecting to the mains.

When cabling, be careful to ensure that no wires are crossed. Before starting electrical work, carefully read and pay attention to the instructions for setting up the system first of all (following pages). The Consul customer service team are available to help with further questions.

On the basis of the supplied circuit diagram and specification VDE 0100, the electrical installation of the lift is to be carried out by a qualified electrician. When actuating the operating switch, the lift must travel according to the direction of the symbols. Where necessary, change the direction by exchanging the two corresponding leads.

Description of the hydraulics

The soft synchronization of the unit with its components ensures smooth control processes in the event of non-synchronization. In contrast to the previous system, the synchronization is controlled by switching on the second lowering valves in the main block. By opening the corresponding second lowering valve, the volume flow of the returning oil is increased in the event of non-synchronization, so that the slower side lowers more quickly for a short time until synchronization is achieved.

Basic setting

Before the first start-up, it must be ensured that the basic setting of the throttles is correct. The throttle with which the speed of the synchronization process is set (1) must be set to 1 ¼ revolutions. To adjust the throttle, you have to loosen the lock nut and screw in the screw completely. Then the screw can be unscrewed according to the respective setting.

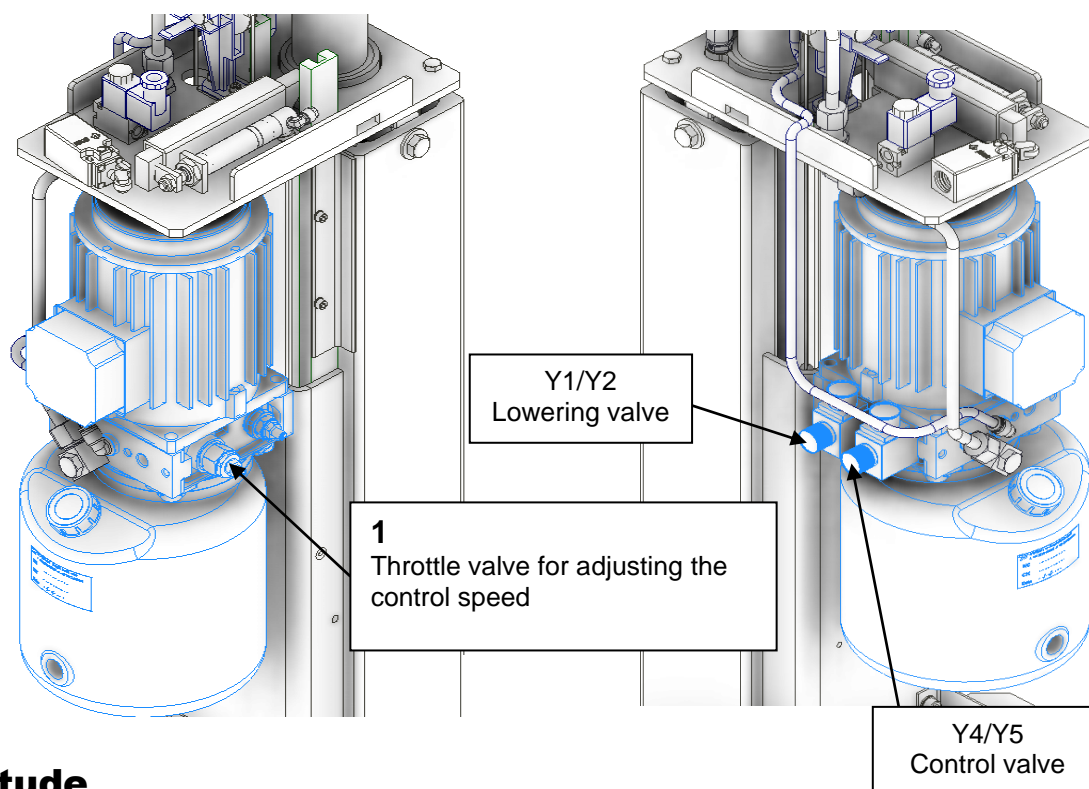

Attitude

The control time can be set using the throttle (1). The duration of the control process should be approx. 1 s.

After the desired settings have been made, please tighten the lock nuts again.

Danger!

The faster the stage is set, the more unclean the stage will be.

Instruction leaflet H480.10 / H458.10 / H495.10

1. Einbau Kugelfanne – Kugelscheibe
(liegende Position)
Installation dimension ball socket - ball washer
(horizontal position)

1.1. Tragarm montieren (stehende Position)
Support arm mount (standing position)

1.2. Einschwenkhöhe (Tragarm – Boden) prüfen und
ggf. Kugelscheibe nach justieren
Swivel-in height (Support arm – Bottom) check
and poss. adjust ball washer

1.3. Sicherheitsmutter montieren
Install safety nut

2. Installationsanweisung Zahnriemen und Gegengewicht (stehende Position)
Installation instructions toothed belt and counterweight (standing position)

3. Sicherung
Achtung: Sicherung erst entfernen wenn die Hebebühne aufgestellt wurde. (stehende Position / Hubwagen auf dem Boden).

Locking device
Important: Remove locking device First when the lift is installed. (standing position / lifting carriage on bottom)

Achtung: Vor der Installation Hub - u. Senkvorang durchführen (stehende Position)

Important: Befor installation lifting and lowering the lift (standing position)

Vorsichtig einführen.
Nicht fallen lassen.
Zahnriemen verdrehen
Vermeiden

Carefully insert.
Do not drop.
Avoid twisting
toothed belt

Zahnriemen an der Absetzstange befestigen (siehe Gegengewicht) (stehende Position)

Toothed belt fixed at the locking bars (see counterweight) (standing position)

Transport lock H480.10

Transportsicherung / transport lock (H480.10 / H480.20)

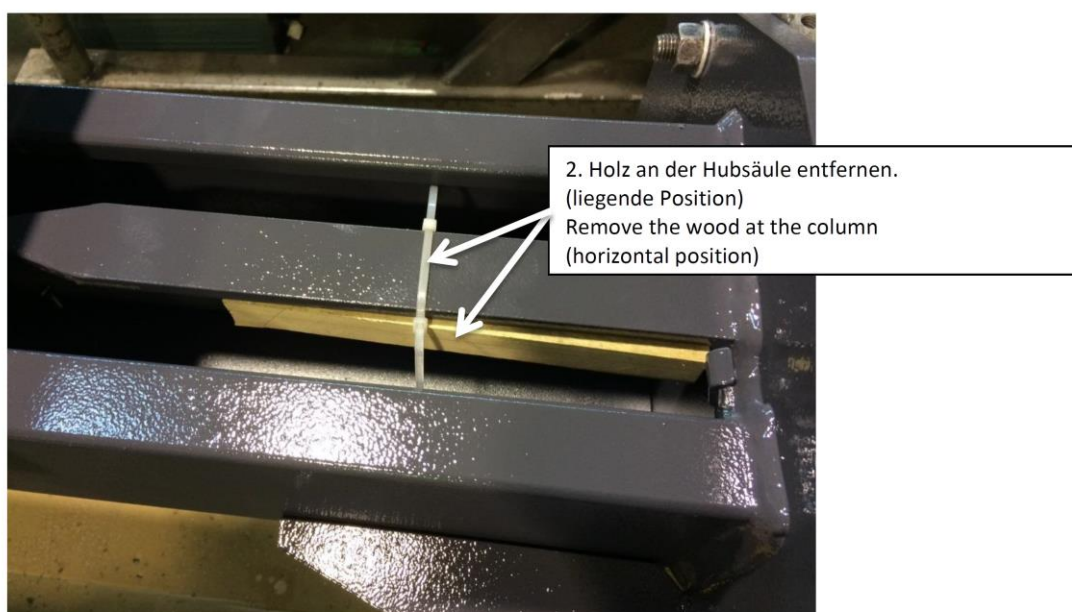
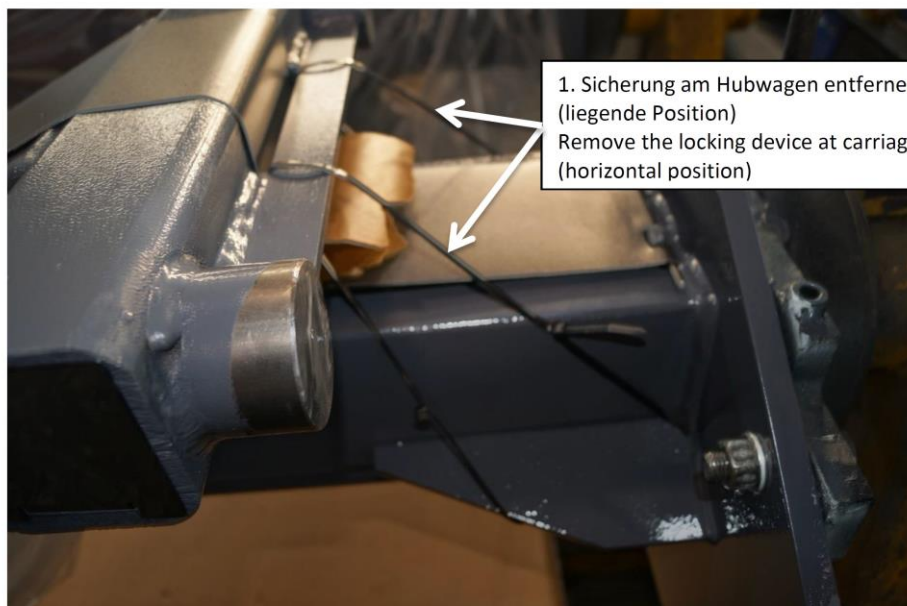

Notice of initialisation for HD lifts

V3.24 up Serial No.:606828 (01.2017)

Switch on the electronic-platine for initial installations and programming

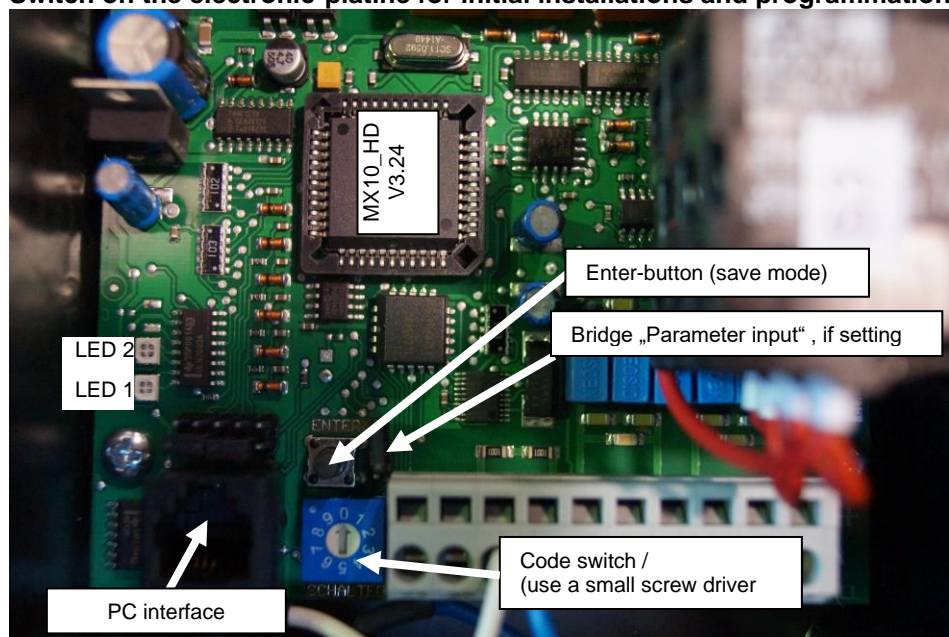

Switch position:

- 0
- 1
- 2
- 3
- 4
- 5
- 6
- 7*
- 8*
- 9*

Function:

- Normal drive mode
- L o w e r limit of carriage
- Synchronisation of carriages
- U p p e r limit of carriage
- Operate mode master column only
- Operate mode slave column only
- Security stop and acoustic signal
- Potentiometer test mode
- Connection, signal and EEPROM test mode
- PC-operation mode / Connection with PC-diagnosis software

*If you encounter any fault during these test modes, this fault will be stored on the EEPROM . The main board cannot be adjusted to normal mode in this case. If normal drive mode is selected, and a fault occurs during test mode, both red and green LED's blink. To overcome this situation, change defective parts or run test mode again.

Programming (Initial installation of the potentiometer already done)

Step:	Switch position:	Enter button:	Function:
A	4	push	operate mode master column only lower the carriage till approx. 10 mm over the ground and 15 mm overrun reserve
B	5	push	operate mode slave column only (as step A)
C	1	push 1 push 2	set lower limit after success of step A and B save mode
D	2	push 1 push 2	synchronisation of carriages save mode
E	0	push	normal operation mode - move both carriages till a height of max.. 1900 mm - evt. lower. (may be last part with 4/5 – operation several column)
F	3	push 1 push 2	set upper limit after success of step E. save mode
G	0	push	normal operation mode lower lift to a min. 200 mm above ground in order to set safety stop
H	6	push 1 push 2	set safety stop after success of step G save mode
I	0	push	normal operation mode - programming finished.

1 push = both LED are green

2 push = both LED are blinking green

Important notice:

If you encounter big differences in voltage or any other problems, it might happen that the main board is shut down automatically for safety purpose. In this case the lift cannot be operated. To make it work again, this can be done usually by turning the main switch on and off again.

Post lift without cover

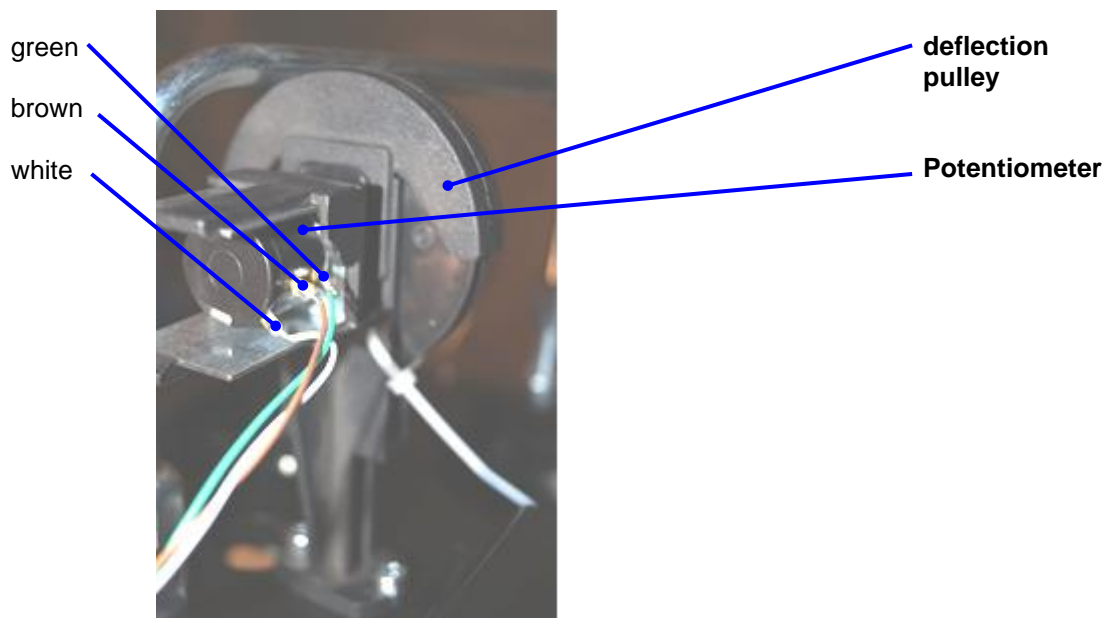

Fig.1

The potentiometer connections P1 and P2 are not marked on the lift. The configuration of the components corresponds to this drawing. The wiring of the potentiometer connections must be carried out according to the colour scheme of the prescribed plan. Incorrect wiring damages the potentiometers

When fitting a new EEPROM or circuit board or in the event of any interruption to the control sequence which cannot be dealt with, carrying out the following steps will help!

To activate EEPROM:

1. Main switch off
2. Place jumper in bridge position
3. Main switch on, diodes flash green / orange
4. Wait three seconds
5. Main switch off
6. Remove the jumper (place in non-bridge position)
7. Main switch on
8. Activate control via position 8 on the program switch and press confirmation switch lower / upper
9. Reinstall stop value and stop position (see above)

Activation / Diagnostic Functions

INSTRUCTION: The lift should be in the middle position in order to allow the necessary travel up and down during the test.

Activation of the diagnostic function by using the code switch position 8, and pressing the "enter" button. On connecting, both LEDs will flash red / green and the buzzer will sound intermittently. The control requires the button to be pressed for up.

Press the **AUF** (up) button. LED1 will show red. LED2 goes out. The safety circuit is checked. If this is all correct, LED1 goes out – LED2 shows red and the electronic relays for upward travel are set in motion. The lift goes up – both LEDs show red.

Press the **AUF** (up) button until the lift stops automatically. Release the button – both LEDs flash orange / green.

Press the **AB** (down) button, LED1 shows orange – LED2 goes out. The safety circuit is checked. If this contains no faults LED1 goes out- LED2 shows orange and the relays for downward travel are activated. The lift travels downwards – both LEDs shows orange.

Press the **AB** (down) button until the lift stops automatically.

Release the button – both LEDs flash green.

Place the code switch in position 0 – press the enter button once – both LEDs show green – test okay - activation of the PC circuit board successful.

If the test runs successfully, a corresponding entry is registered with EEPROM. The lift can only be used normally in position “0” after the successful completion of this test.

If a fault occurs during the test the lift cannot be used in the position “0”. A rerun of the test is only possible after cutting the mains voltage and repeating the above procedure.

Potentiometer Test

Testing the potentiometer against values in the relevant range of values.

Description:

Activation of this operating mode by turning the potentiometer to position 7 and pressing the enter button.

If the reading of the main column potentiometer is in the relevant range, LED1 will flash green. If the reading is greater than 97% it will flash red. If it is less than 3%, it will flash orange.

If the reading of the slave column potentiometer is in the relevant range, LED1 will flash green. If the reading is greater than 97% it will flash red. If it is less than 3%, it will flash orange.

Malfunction Indication

Position 0: Normal operation

Both LEDs show green if no buttons are pressed.

If the upwards (up) buttons are pressed both LEDs show red.

If the downwards (down) buttons are pressed both LEDs show orange.

The following faults are possible:

PROBLEM: Both LEDs show red

REASON: A fault has occurred in EEPROM

SOLUTION: The parameters must be reduced through the jumpers, and then the control mechanism must be retuned. If this does not work, the control mechanism must be replaced.

PROBLEM: Both LEDs flash orange / green at the same time

REASON: The control mechanism must be initialised.

SOLUTION: code switch in position 8 and carry out tuning.

PROBLEM: One or both LEDs flash red / green alternately

REASON: The minimum speed was overridden

SOLUTION: Turn the control mechanism off and on. If the fault reoccurs, check the mechanism.

PROBLEM: One or both LEDs flash red

REASON: The upper stop point of that particular pillar has been reached

SOLUTION: The pillar can only be driven in a downward direction.

PROBLEM: One or both LEDs flash orange

REASON: The lower stop point of the relevant pillar has been reached

SOLUTION: The pillar can only be driven in an upward direction

PROBLEM: One or both LEDs flash orange and the alarm buzzer sounds

REASON: The lower stop contact of that particular pillar has been overridden.

SOLUTION: The lift must be relevelled. Further operation is not possible.

PROBLEM: Both LEDs flash alternately orange / red and the alarm sounds
REASON: The maximum allowed distortion between the pillars has been overridden
SOLUTION: The lift must be relevelled. Further operation is not possible.

PROBLEM: After switching on, the buzzer gives three short sounds
REASON: The internal real time clock is not correctly set
SOLUTION: The clock must be set using the PC – configuration software.

PROBLEM: LED1 is out. LED2 shows red
REASON: The control mechanism has detected a defect in its programmable memory.
SOLUTION: If the fault reoccurs after a break in the current, replace the EEPROM or the control memory circuit board.

PROBLEM: Both LEDs flash orange / green alternately. During downward travel, both motors suddenly stop, although both the LEDs show orange.
REASON: The stop position has been reached.
SOLUTION: Release the button and press again

PROBLEM: On downward travel, the alarm buzzer sounds
REASON: The level is below the stop position
SOLUTION: It is normal for the buzzer to sound during downward movement below the stop position.

PROBLEM: One of the motors cuts out during movement. The relevant LED shows green.
REASON: The control mechanism is re-establishing the even running of the pillars
SOLUTION: This behaviour is normal.

PROBLEM: One or both LEDs flash red and the alarm buzzer sounds
REASON: The upper stop contact of that particular pillar has been overridden.
SOLUTION: The lift must be relevelled. Further operation is not possible.

PROBLEM: Both LEDs flash orange / green alternately.
REASON: The parameters are not in the correct order.
LOWER STOP VALUE <STOP POINT< UPPER STOP VALUE
SOLUTION: Realign the stop contacts and stop points according to the above rule.

PROBLEM: After the detent button has been pressed too long, the lift will beep in the interval
REASON: Monitoring, no potentiometer movement - The detent button has been pressed too long
SOLUTION: Switch off main switch, then switch on (error has been reset)

Drive Modes

Position 4: To control the drive pillar directly

1. Turn the code switch to position 4 and press enter. (The LEDs go out briefly while the button is being pressed and flash green upon release).
2. By pressing the “Hoch” (up) button, the pillar goes up. LED1 flashes red.
3. By pressing the “Runter” (down) button the pillar goes down. LED1 flashes orange.

BEWARE: No monitoring of the programmed stop point will follow this.

Position 5: To control the secondary pillar directly

1. Turn the code switch to position 5 and press enter. (The LEDs go out briefly while the button is being pressed and flash green upon release).
2. By pressing the “Hoch” (up) button, the pillar goes up. LED2 flashes red.
3. By pressing the “Runter” (down) button the pillar goes down. LED2 flashes orange.

BEWARE: No monitoring of the programmed stop point will follow this.

Position 1: Down stop contacts

1. Run the motors with position 4 and position 5 to the required lower point.
2. Turn the code switch to position 1 and press enter. (The LEDs go out briefly during the pressing of the button and show green on being released).
3. By pressing “enter” again the stops are programmed. The LEDs flash green alternately.
4. A further pressing of “enter” reconnects to point 2.

The following faults are possible:

PROBLEM: After carrying out point 3, both LEDs show red.

REASON: The parameters could not be programmed into EEPROM so as to be secure against failure of the current.

SOLUTION: Repeat tuning. If the problem reoccurs, the control mechanism must be replaced. In this situation, press the “enter” button to return to point 2.

Position 3: Upper stop contacts

1. Run motors with position 4 and position 5 to the required upper connection point.
2. Turn the code switch to position 3 and press “enter”. (The LEDs go out briefly whilst the button is being pressed and show green after release).
3. By pressing “enter” again the stops are programmed. The LEDs flash green alternately.
4. A further pressing of “enter” reconnects to point 2.

The following faults are possible:

PROBLEM: After carrying out point 3, both LEDs show red.

REASON: The parameters could not be programmed into EEPROM so as to be secure against failure of the current.

SOLUTION: Repeat tuning. If the problem reoccurs, the control mechanism must be replaced. In this situation, press the “enter” button to return to point 2.

Position 6: Stop point

1. Run the motors with position 4 and 5 to the required stopping point.
2. Turn the code switch to position 6 and press “enter”. (The LEDs go out briefly whilst the button is being pressed and show green after release).
3. By pressing enter again the stops are programmed. The LEDs flash green alternately.
4. A further pressing of “enter” reconnects to point 2.

The following faults are possible:

PROBLEM: After carrying out point 3, both LEDs show red.

REASON: The parameters could not be programmed into EEPROM so as to be secure against failure of the current.

SOLUTION: Repeat tuning. If the problem reoccurs, the control mechanism must be replaced. In this situation, press the “enter” button to return to point 2.

Position 2: Post differential

1. Align the motors with position 4 and position 5 as required (height difference = 0).
2. Turn the code switch to position 2 and press “enter”. (The LEDs go out briefly whilst the button is being pressed and show green after release).
3. By pressing “enter” again the stops are programmed. The LEDs flash green alternately.
4. A further pressing of “enter” reconnects to point 2.

PROBLEM: After carrying out point 3, both LEDs show red.

REASON: The parameters could not be programmed into EEPROM so as to be secure against failure of the current.

SOLUTION: Repeat tuning. If the problem reoccurs, the control mechanism must be replaced. In this situation, press the “enter” button to return to point 2.

Position 7: Testing the potentiometer

1. Turn the code switch to position 7 and press “enter”. (The LEDs go out briefly while the button is being pressed).

LED flashes orange – the corresponding potentiometer is in the non-permitted zone 0-3%

LED flashes green – the corresponding potentiometer is in the permitted zone 3-97%

LED flashes red – the corresponding potentiometer is in the non-permitted zone 97-100%

Position 8: Initialising the control mechanism

1. Turn the code switch to position 8 and press “enter”. (The LEDs flash red / green and the buzzer sounds intermittently after pressing the button).
2. Press the up button and hold pressed until the lift cuts out automatically.
3. LED1 shows red, LED2 is out. The relays for upward travel are activated. The lift cannot move.

The following faults are possible:

PROBLEM: After carrying out point 2, LED1 flashes red.

REASON: The lift has moved although the safety relay has not switched on.

SOLUTION: Turn the control mechanism off and on. Repeat the test, check the wiring, and if necessary replace the control mechanism.

4. LED1 is out, LED2 shows red, only the safety relay is activated, the lift cannot move.

PROBLEM: After carrying out point 4, LED2 flashes red.

REASON: The lift has moved although the safety relay has not switched on.

SOLUTION: Turn the control mechanism off and on. Repeat the test, check the wiring, and if necessary replace the control mechanism.

5. LED1 and LED2 show red, the safety relay and the relays are activated for up. The lift must move upwards.

PROBLEM: After carrying out point 5, LED1 and LED2 flash red.

REASON: The lift has not moved although the safety relays and direction relays have switched on.

SOLUTION: Turn the control mechanism off and on. Repeat the test, check the wiring, and if necessary replace the control mechanism.

6. Both LEDs show green. Release the "up" button.

7. The LEDs flash orange / green and the buzzer sounds intermittently after pressing the button.

8. Press "down" button and hold it until the lift cuts out automatically.

9. LED1 shows orange, LED2 is out and the relays are activated for downward. The lift cannot move.

The following faults are possible:

PROBLEM: After carrying out point 9, LED1 flashes orange.

REASON: The lift has moved although the safety relay has not switched on.

SOLUTION: Turn the control mechanism off and on. Repeat the test, check the wiring, and if necessary replace the control mechanism.

10. LED1 is out, LED2 shows orange, and only the safety relay is activated. The lift cannot travel.

PROBLEM: After carrying out point 10, LED2 flashes orange.

REASON: The lift has moved although the safety relay has not switched on.

SOLUTION: Turn the control mechanism off and on. Repeat the test, check the wiring, and if necessary replace the control mechanism.

11. LED1 and LED2 show orange, the safety relay and the relays are activated for down. The lift must travel downwards.

PROBLEM: After carrying out point 11, LED1 and LED2 flash orange

REASON: The lift has not moved although the safety relays and direction relays have switched on.

SOLUTION: Turn the control mechanism off and on. Repeat the test, check the wiring, and if necessary replace the control mechanism.

12. Both LEDs flash green. Release the down button, the test is complete; the control mechanism can be switched to position 0 again.

NOTE: If the test under point 8 is not carried out completely then the lift can no longer be used in position 0.

Schematic drawing 2.35 HD Flex H480.12-54778.6

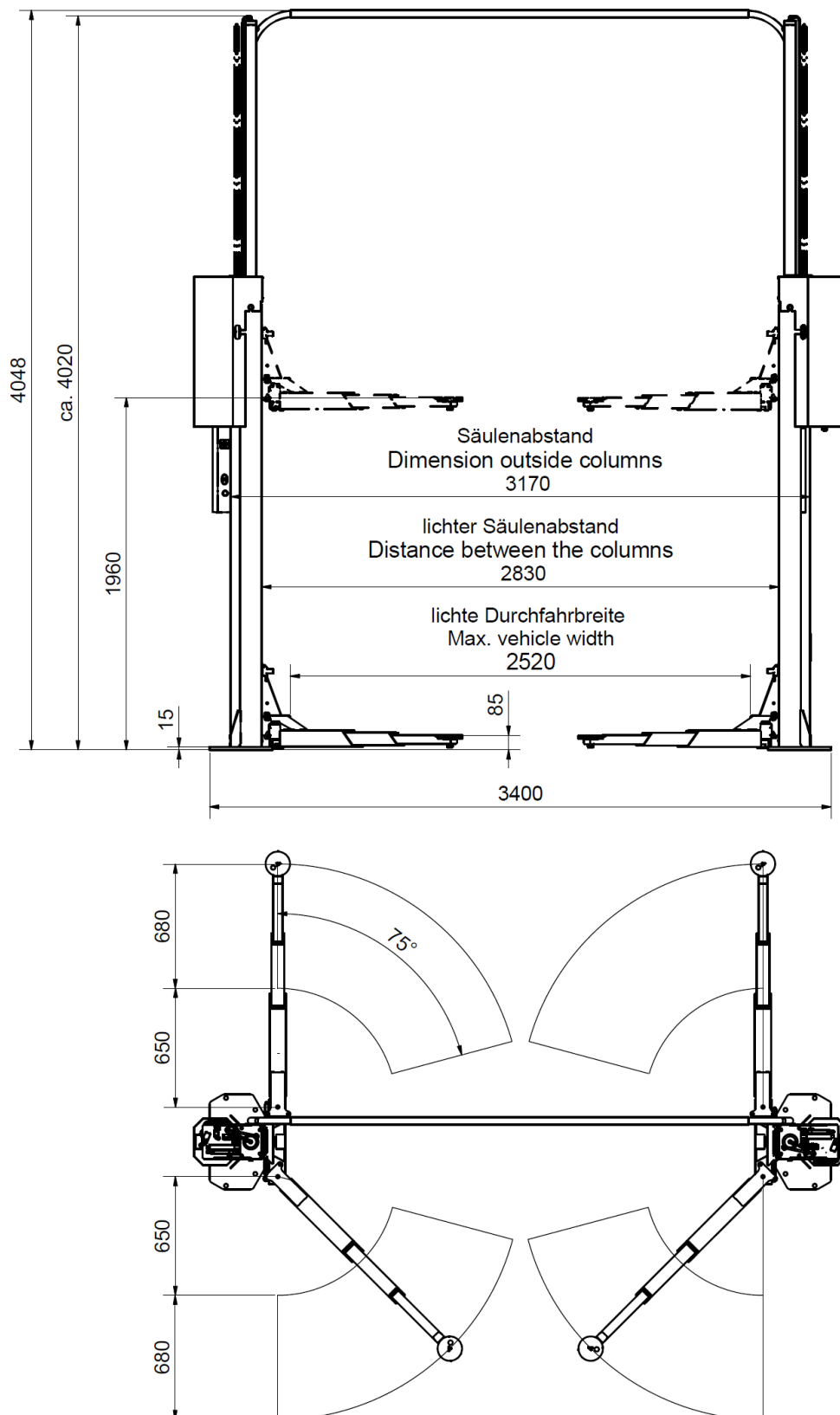

Subject to change without prior notice!

Schematic drawing 2.40 HD Flex H480.12-53832.2

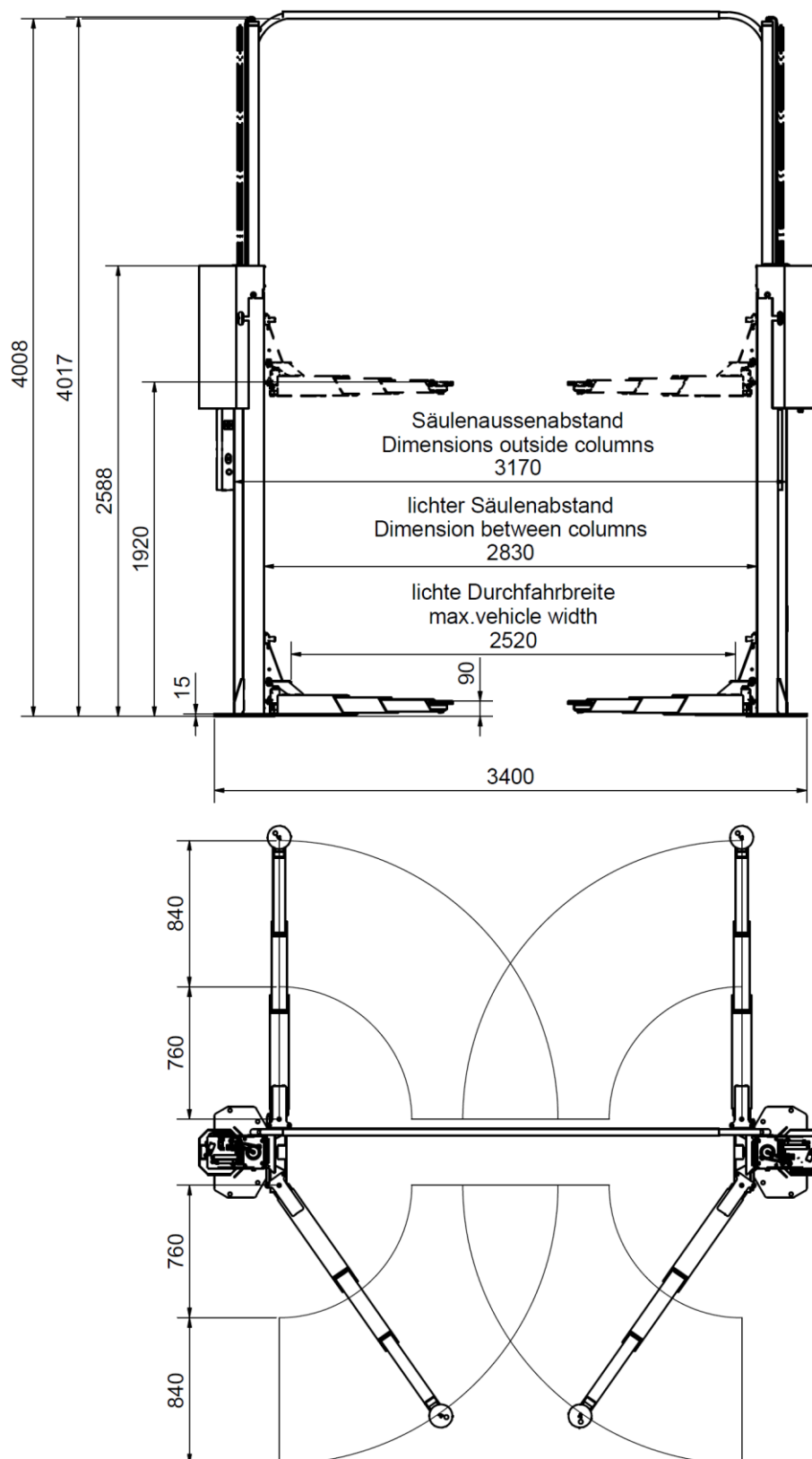

Subject to change without prior notice!

Schematic drawing 2.45 HD Flex H495.12-58800.4

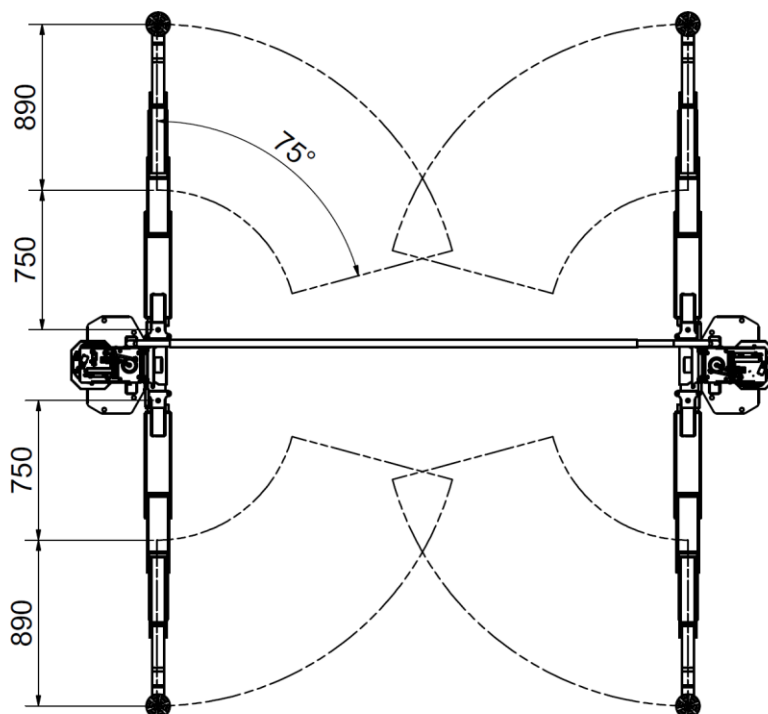
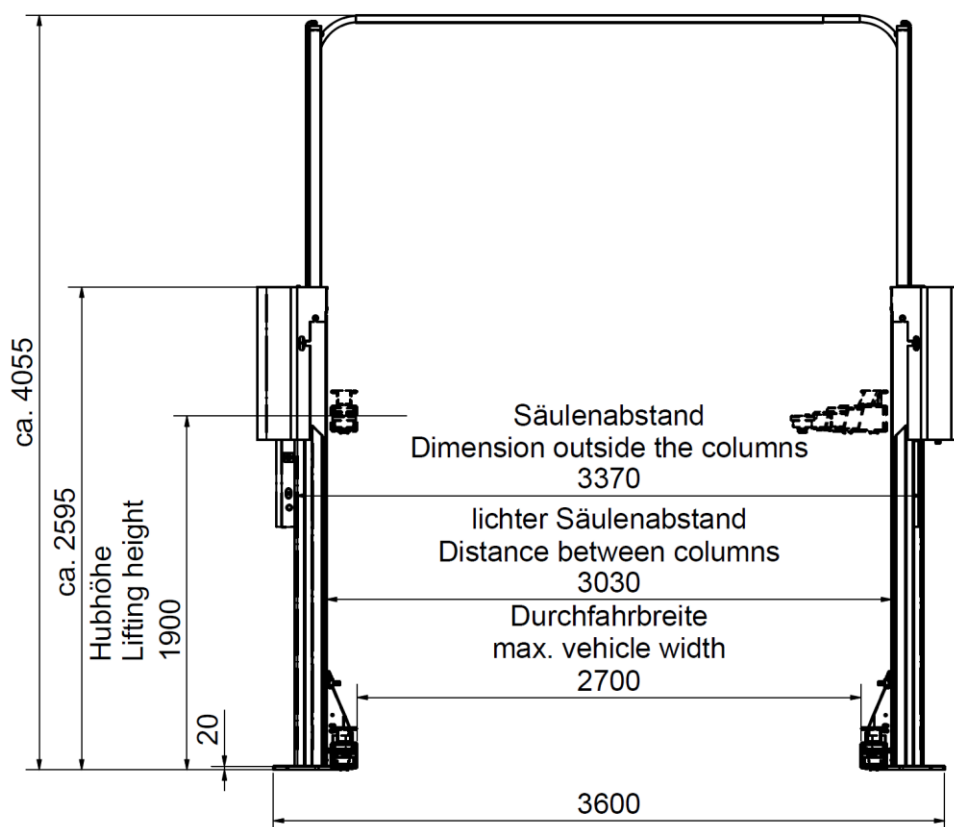

Schematic drawing 2.55 HD Flex H458.12-53917.1

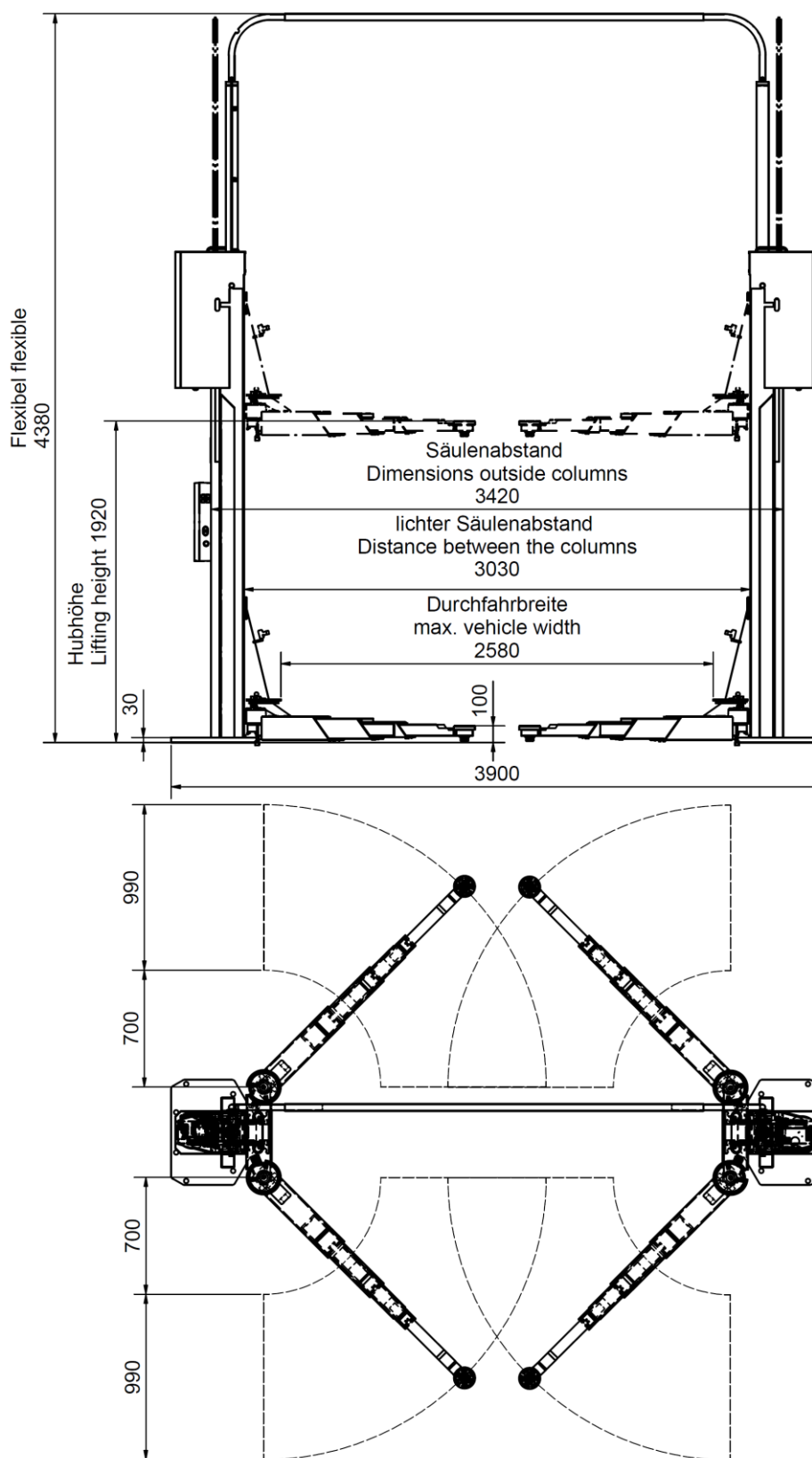

Subject to change without prior notice!

Schematic drawing 2.55 HD G Flex H458.12-57210.7

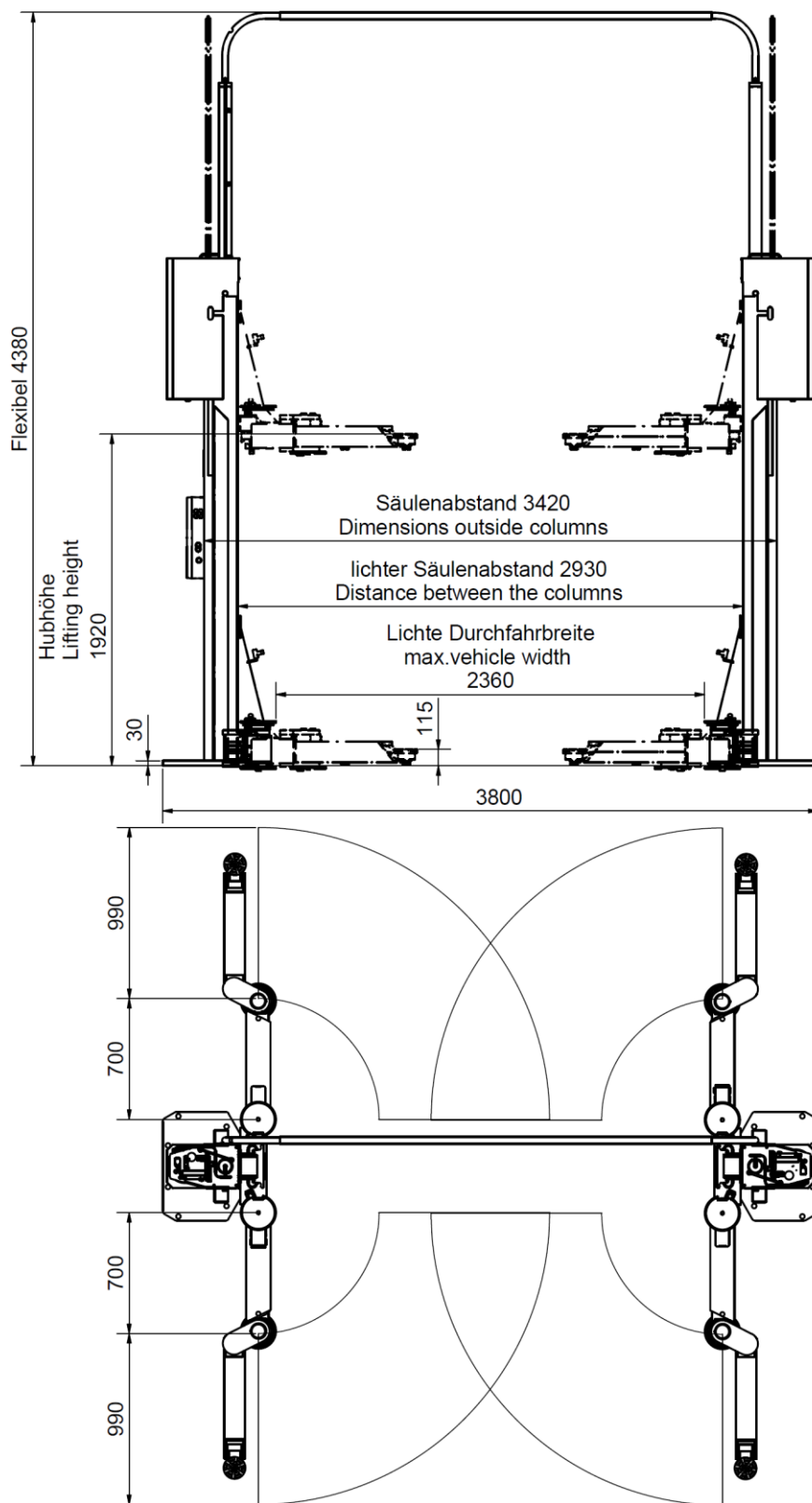

Subject to change without prior notice!

Schematic drawing 2.65 HD Flex 54779.4

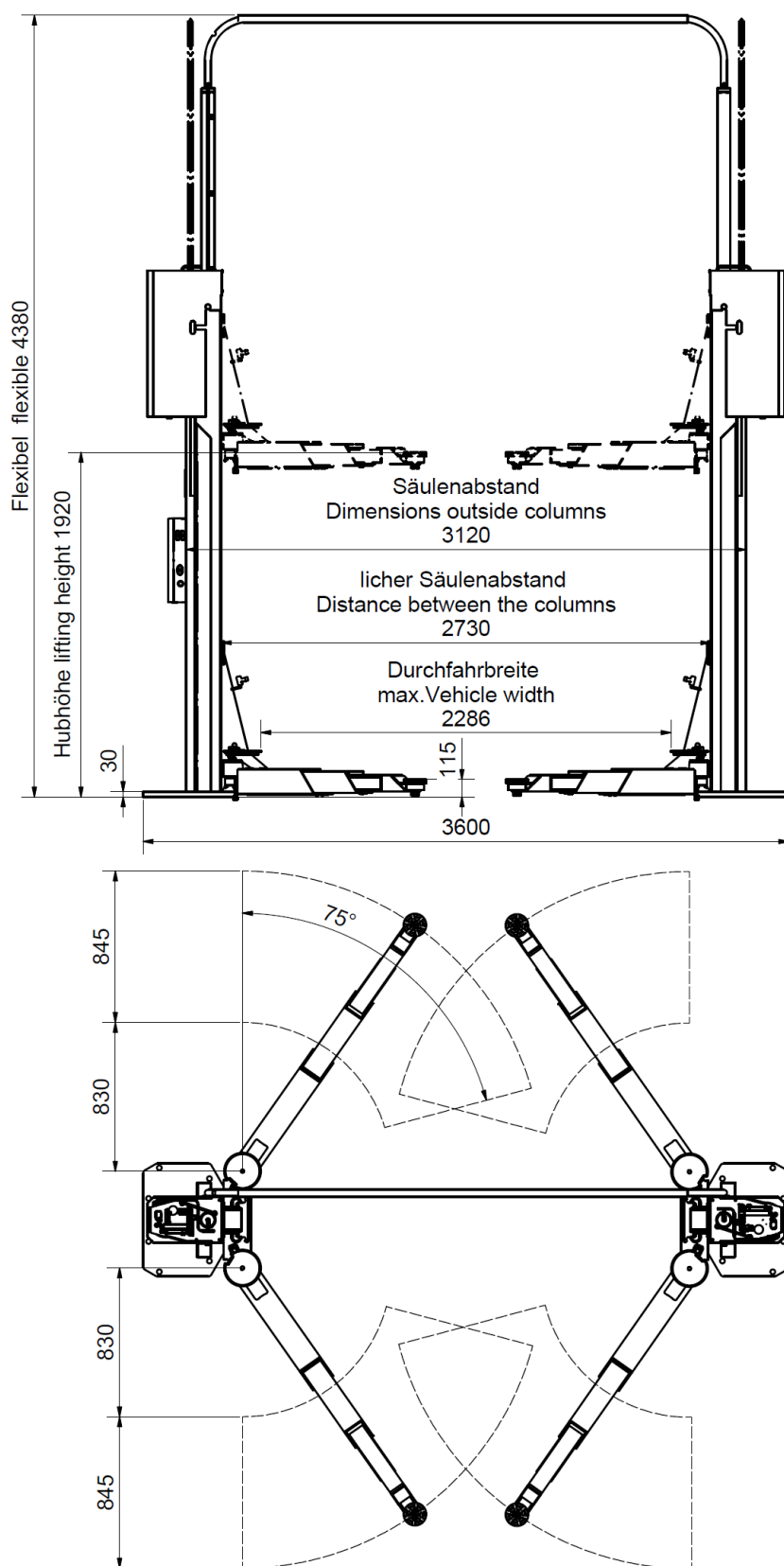

Subject to change without prior notice!

Schematic drawing 2.70 HD Flex 59045.5

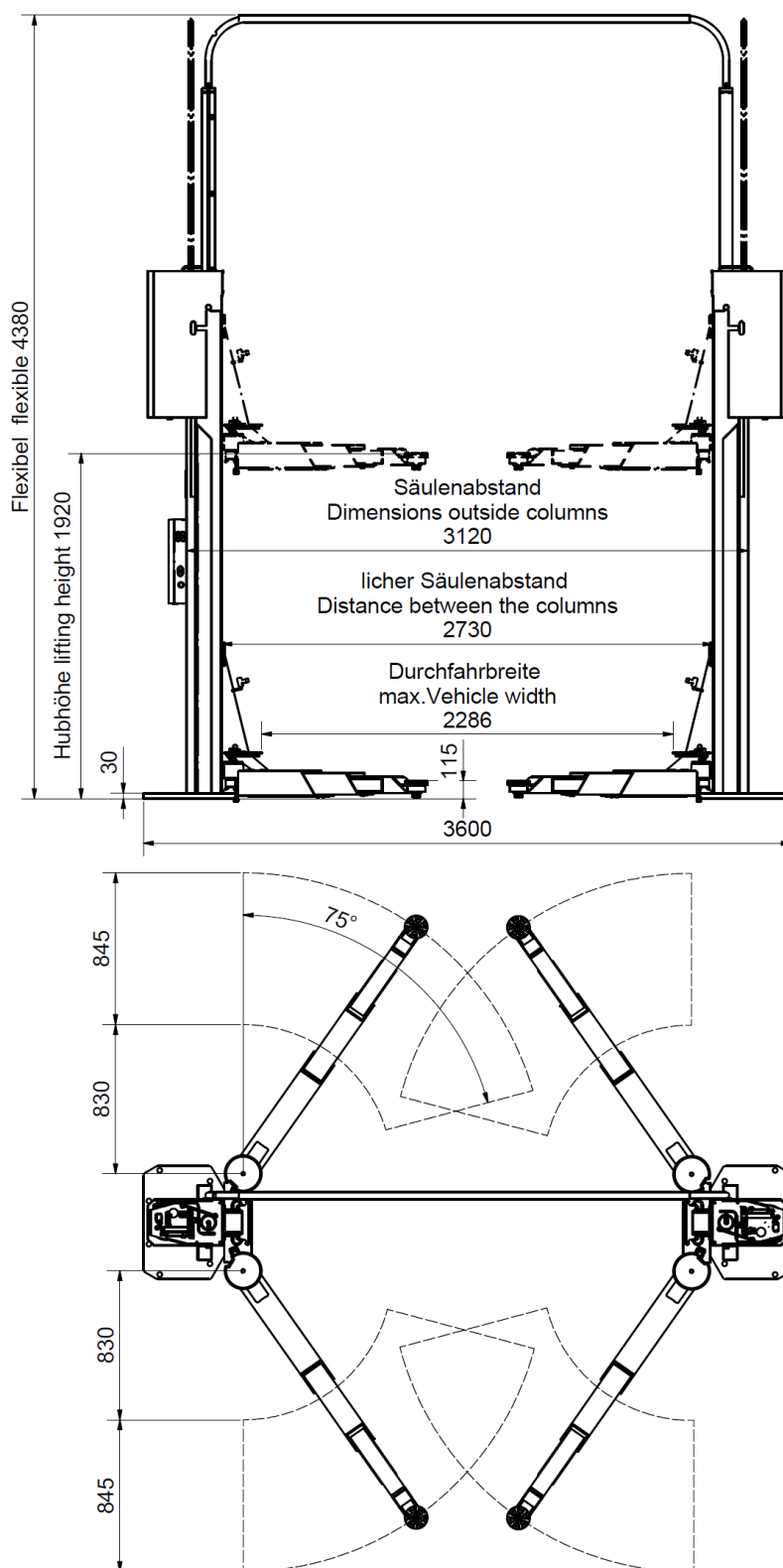

Subject to change without prior notice!

Technical Data

Typ:	H480.10-54778.6 2.35 HD Flex	H480.10-53832.2 2.40 HD Flex	H495.10-58800.4 2.45 HD Flex	H458.10-53917.1 2.55 HD Flex	H458.10-57210.7 2.55 HD- G Flex	H458.10-54779.4 2.65 HD Flex	H458.10-59045.5 2.70 HD Flex
Model:	with asymmetric bearing arms	with symmetric bearing arms	with symmetric bearing arms	with asymmetric bearing arms	with with tiltable swivel arms	with symmetric bearing arms	with symmetric bearing arms
Width (mm):	3.400	3.400	3.600	3.900	3.800	3.600	3.600
min Height (mm):	4.065	4.065	4.065	4.380	4.380	4.380	4.380
max. Height (mm) approx:	4.565	4.565	4.565	4.880	4.880	4.880	4.880
Clearance stroke width (mm):	2.510	2.510	2.700	2.360	2.360	2.360	2.360
Lifting distance (mm):	1.840	1.840	1.840	1.830	1.830	1.830	1.830
Lifting height (mm):	1.930	1.930	1.930	1.920	1.920	1.965	1.965
min. lower pivot height (mm):	ca.90	ca.90	ca.90	100	115	115	115
Lifting time (sec):	23	23	23	23	23	23	23
Net weight (kg):	700	700	800	1.500	1.500	1.500	1.500
Load capacity (kg):	3.500	4.000	4.500	5.500	5.500	6.500	7.000
Outer diameter of cylinder (mm)	60	60	60	72	72	72	72
Piston diameter (mm)	25	25	25	30	30	30	30
Operating pressure (bar)	260	260	260	260	260	260	260
Oil filling level (Litres)	2 x 4	2 x 4	2 x 4	2 x 5	2 x 5	2 x 5	2 x 5
Hydraulic oil	HLP 22	HLP 22	HLP 22	HLP 22	HLP 22	HLP 22	HLP 22
Motor output (kW):	2 x 2,2	2 x 2,2	2 x 2,2	2 x 2,2	2 x 2,2	2 x 2,2	2 x 2,2
Supply (V):	400	400	400	400	400	400	400
Power on-time operation:	S3	S3	S3	S3	S3	S3	S3
Current consumption (A):	16	16	16	16	16	16	16
Fuse protection (A gl):	20	20	20	20	20	20	20
Sound intensity level (dB(A)):	78	78	78	78	78	78	78

Hydraulic drive unit (704924) with 5L-Oil Tank

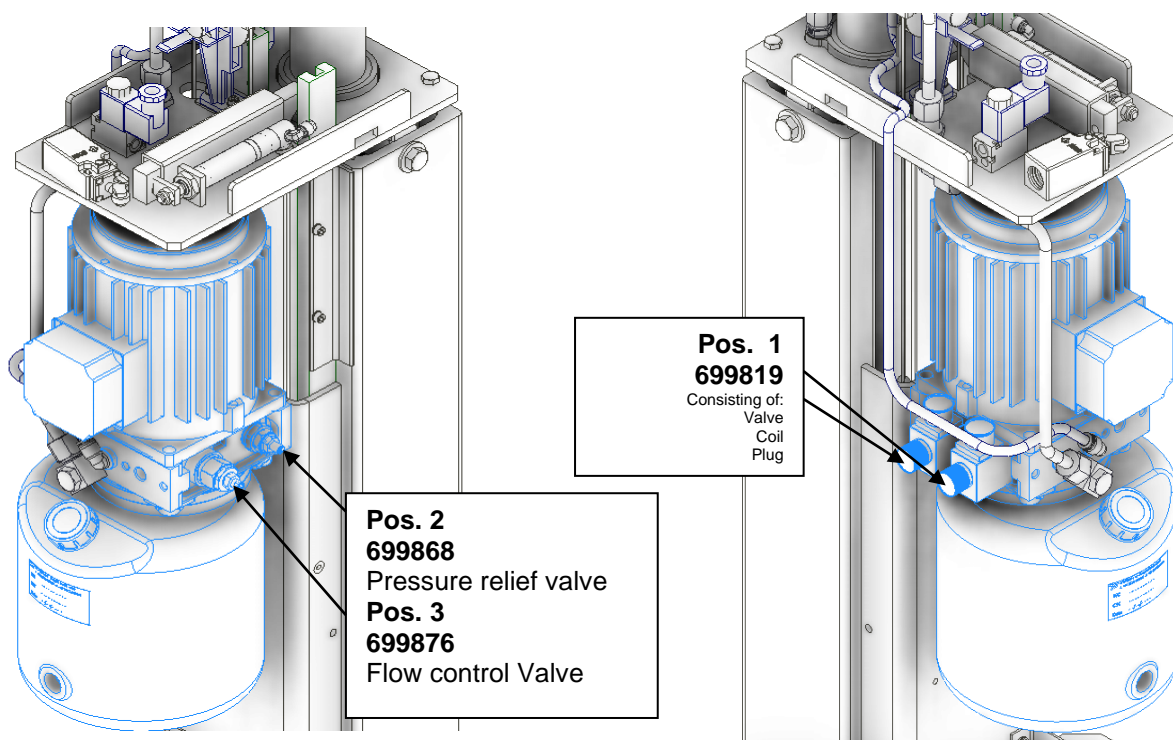

Pos.	Piece	Description	Old hydraulic Unit	New hydraulic unit
1	1	2/2-Way-Valve cpl.	55622.5 Valve, Coil and Plug,	699819 consisting of: Valve coil Plug
1.1	1	Valve	55619.1 Valve el. Ø12,7 AC	699827 Valve el. Ø12,7 DC gC F72007B1
1.2	1	Coil	55620.9	699835
1.3	1	Plug	55621.7 Plug	699843 Plug
2	1	Pressure relief valve	55618.3	699868
3		Flow control valve		699876

Subject to change without prior notice!
Stand: 08/2020

Hydraulic drive unit (702134) with 7 Liter-Tank

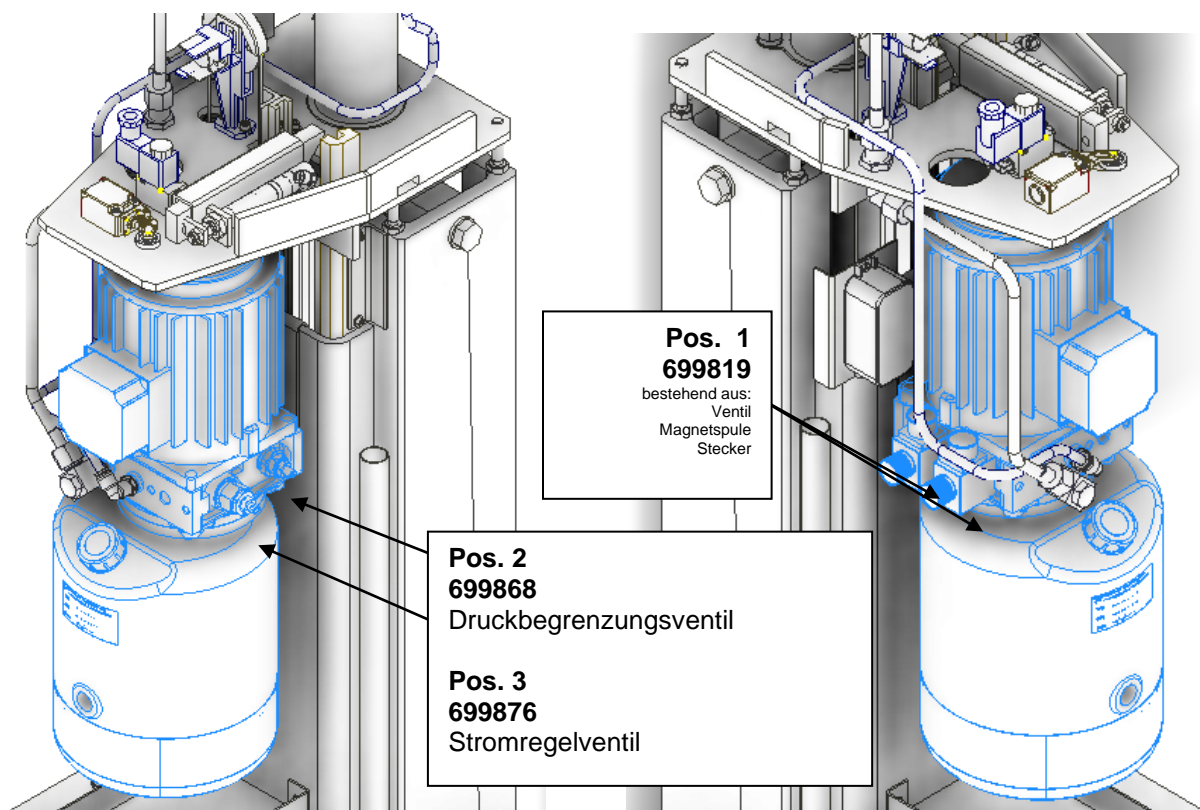

Pos.	Piece	Description	Old hydraulic Unit	Old hydraulic Unit
1	1	2/2-Way-Valve cpl.	55622.5 Ventil, Magnetspule und Stecker,	699819 bestehend aus: Ventil Magnetspule Stecker
1.1	1	Valve	55619.1 Ventil Ø12,7 AC	699827 Ventil Ø12,7 DC gC
1.2	1	Coil	55620.9 Spule	699835 Spule sovr.
1.3	1	Plug	55621.7 Stecker	699843 Stecker
2	1	Pressure relief valve	55618.3	699868
3		Flow control valve		699876
4	1	7 Liter Oil tank	574384	574384

Subject to change without prior notice!
Stand: 08/2020

Lifting cylinder 5 to (53893.4)

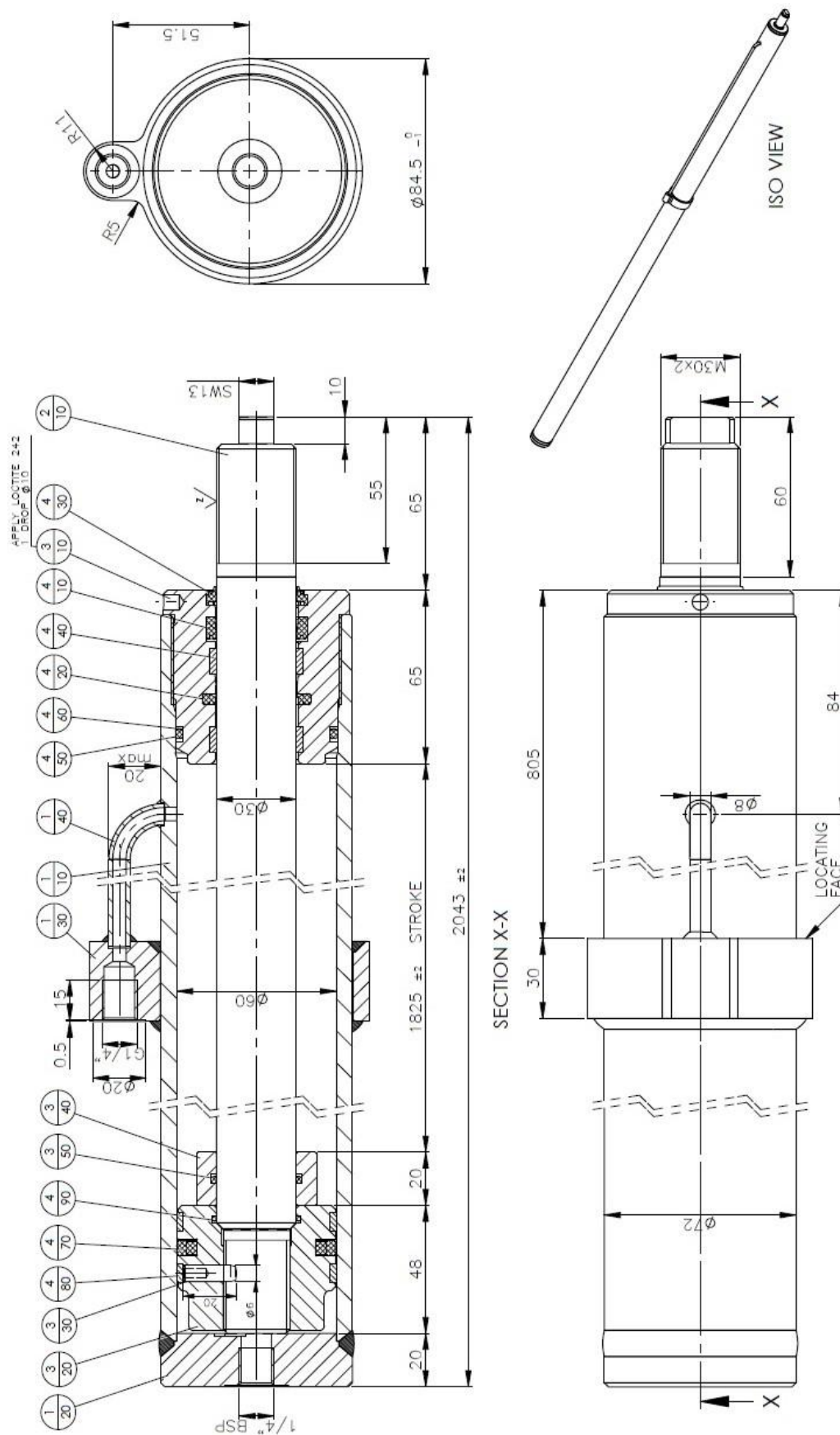

Hydraulic diagramm

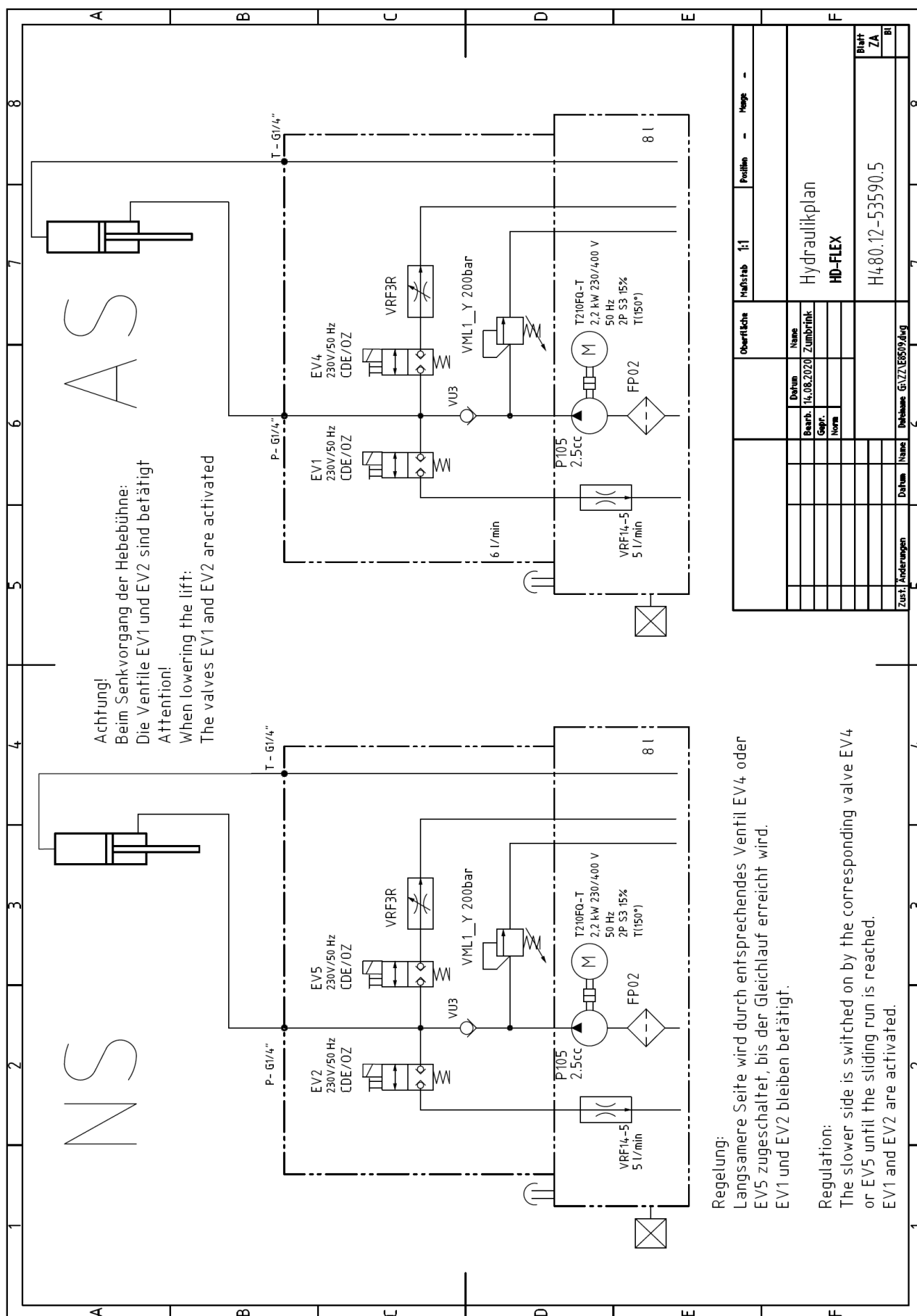

Emergency lowering

Notes:

The implementation of an emergency lowering as described in the following is only to be carried out by authorized instructed persons.

A second person competent must stand outside of the danger area, to observe the lift area for the safety of persons and material.

Where a threat emerges, quit the travelling movement straight away. Continue only after the eliminating the danger. Only one single trip to the base position is allowed.

If necessary, request the CONSUL customer service team.

Carrying out emergency lowering

Caution:

By no means solve the emergency manual lowering, while personnel are under the vehicle.

Should a hydraulic emergency lowering be required (in case of power failure, failure of the pump or motor) is the bearing unit should be lowered by hand.

Before starting emergency lowering, secure the bearing unit / vehicle with appropriate supporting elements (bars etc.) against unintentional lowering.

First leave the danger area and then leave the supporting elements again.

Attention: The latch fuse may not settle in the locking bars.

The latch fuse must be secured against notches.

In Mutually (1 person): Max 200mm / page.

In emergency lowering with 2 people: coordinate discountinuation of the vehicle.

Now, carefully release emergency discharge screw a little

Warning! Watch the lowering speed.

If the lowering process is interrupted, the valve must be turned down again.

After the vehicle was safely lowered and driven from the lift, the valve must be fixed again be attracted.

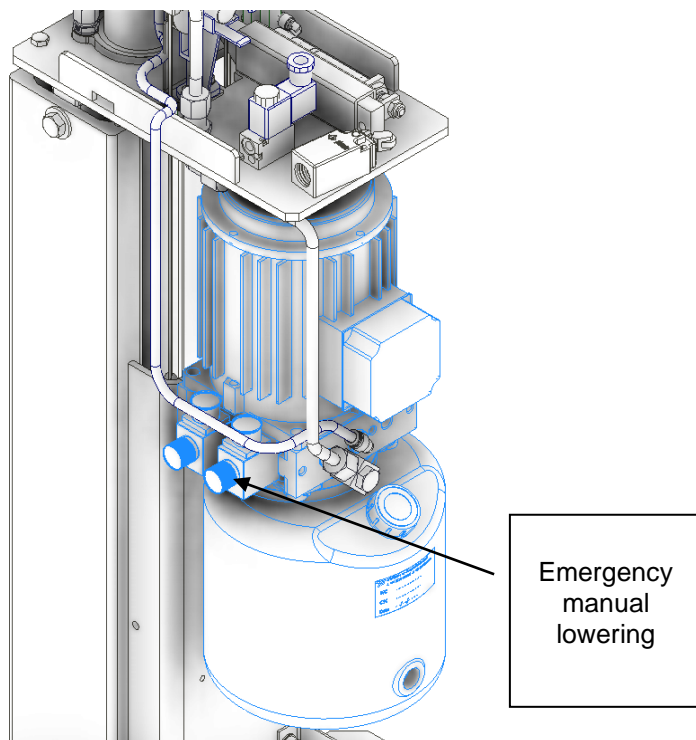

Warning!: No automatic final shut off.

The lift can once only again be operated after the elimination of all faults by an authorized person to do this.

Hydraulic oil HLP22

Description

High performance hydraulic oil of high quality refined products with optimal wear protection in boundary friction (AW additives) and high load carrying capacity of the lubricant film. Excellent Thermal and oxidation resistance for long service life. Antioxidants and corrosion inhibitors, high aging and temperature stability, no foaming, good demulsification. Steel, non-ferrous and light metals and their alloys are not attacked. Tolerant of commercially available sealing materials.

Specifications/approvals:
Hydraulic oil DIN 51524 - HLP 22

characteristics ca. values

ISO-Viscosityclass	DIN 51519	VG	22
Viscosity at 40 °C	DIN 51562	mm ² /s	22
Viscosity at 100 °C	DIN 51562	mm ² /s	4,3
Viscosity Index	DIN ISO 2909		100
Density at 15 °C	DIN 51757	g/cm ³	0,88
Flash Point	DIN ISO 2592	°C	206
Pourpoint	DIN ISO 3016	°C	-26
Ash, oxide	DIN 51575	g/100g	0,17
Neutralization nuber, sour	DIN 51558 Teil 1	mg KOH/g	0,5
Corr. effect on copper	DIN 51759	Korr.-Gr.	1-125 A3
Schäumungseigenschaften	DIN 51566	S1B-30/0 S2B-50/0 S3B-30/0	
FZG-gear short test Normal Test A/8,3/90	DIN 51354 load stage		10

Electric diagram

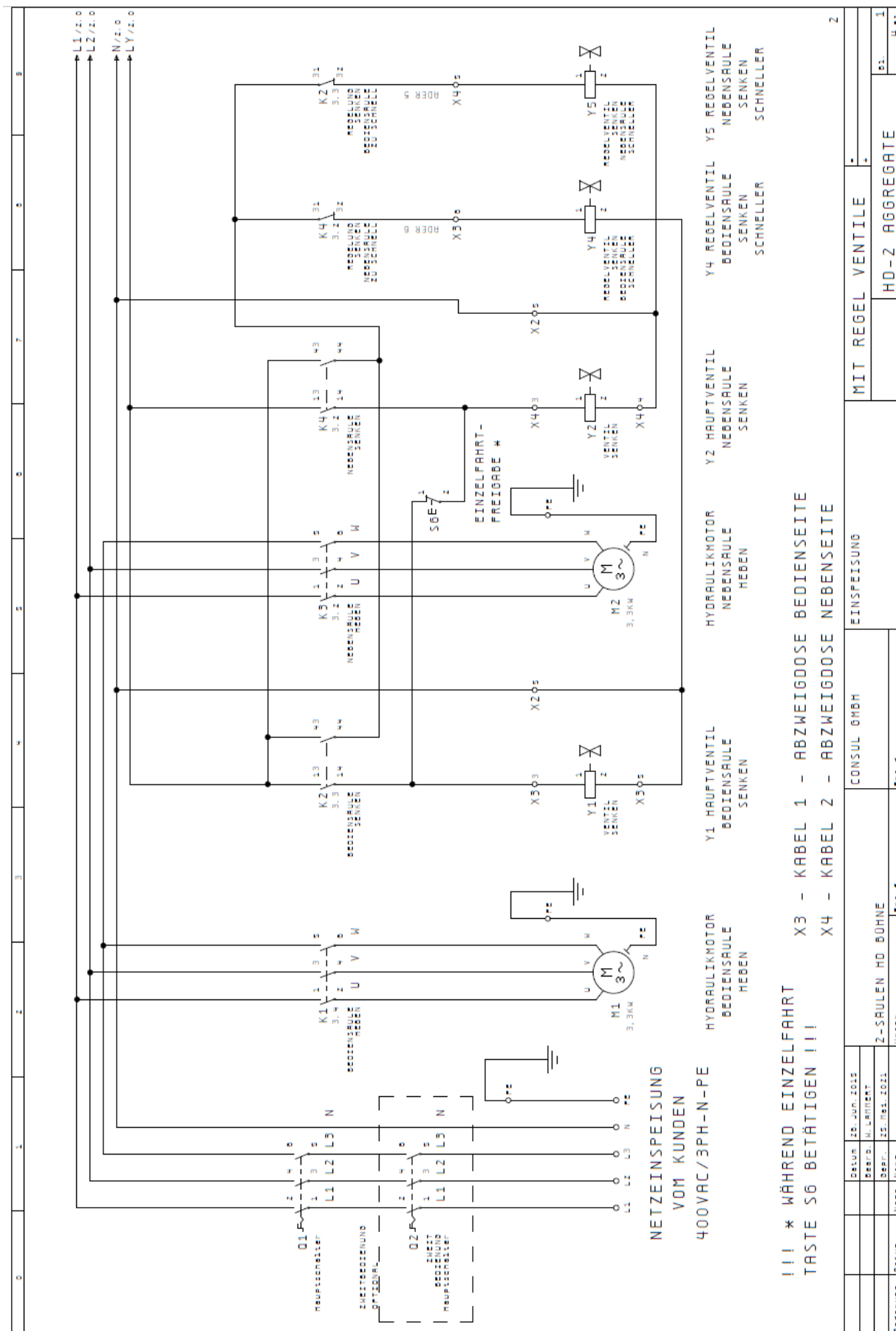

!!! * WÄHREND EINZELFAHRT TASTE S6 BETÄTIGEN !!!
X3 - KABEL 1 - ABZWEIGDOOSE BEDIENSEITE
X4 - KABEL 2 - ABZWEIGDOOSE NEBENSEITE

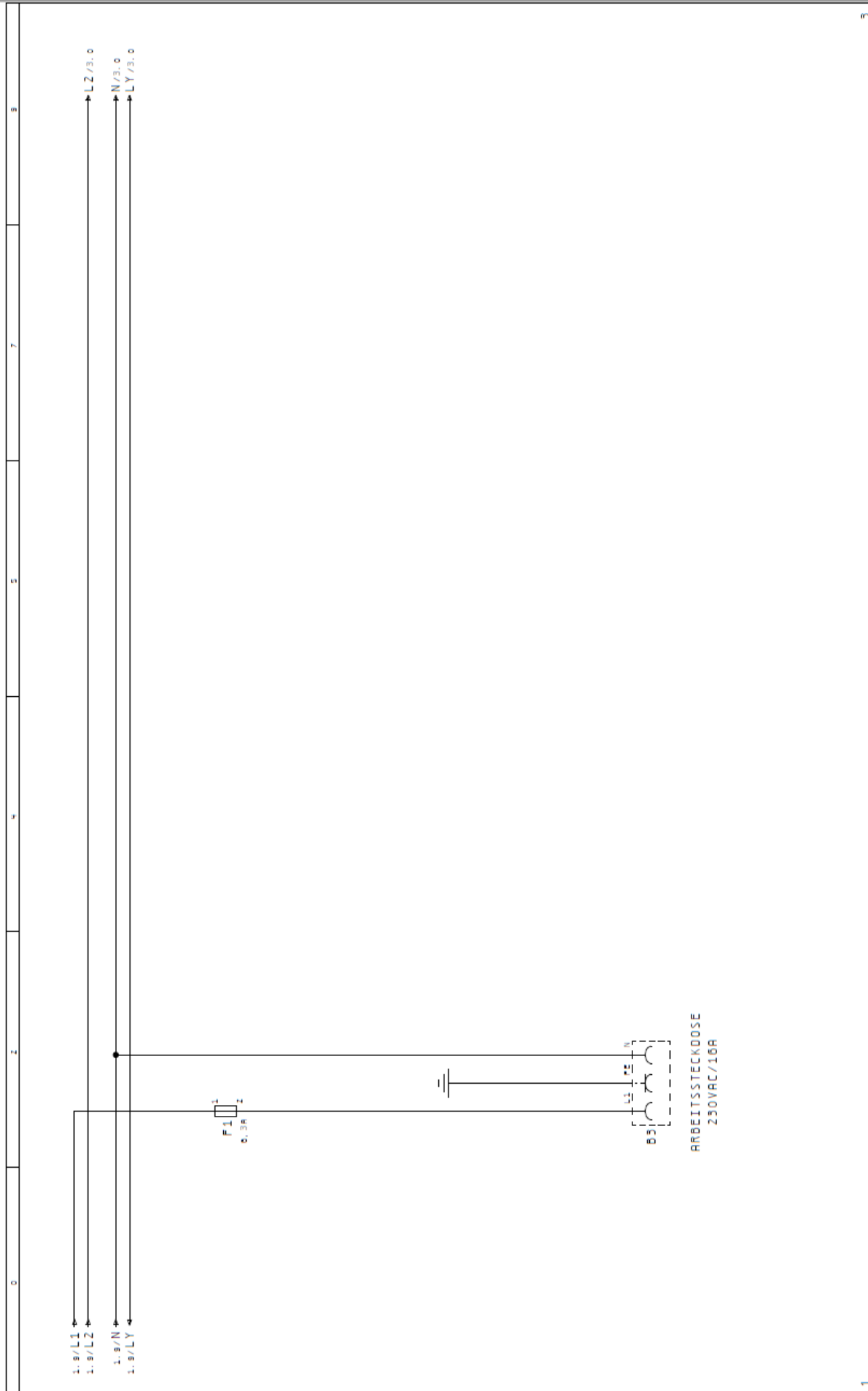

1																	3
													MIT REGEL VENTILE				
														HD-2 AGGREGATE			
ARBEITSSTECKDOSE													STEUERUNG				
230VAC/16A													CONSUL GMBH				
Z-SÄULEN HD BÜHNE																	
Grafik																	
Grafik																	
Grafik																	
Grafik																	
Grafik																	
Grafik																	
Grafik																	
Grafik																	
Grafik																	
Grafik																	
Grafik																	
Grafik																	
Grafik																	

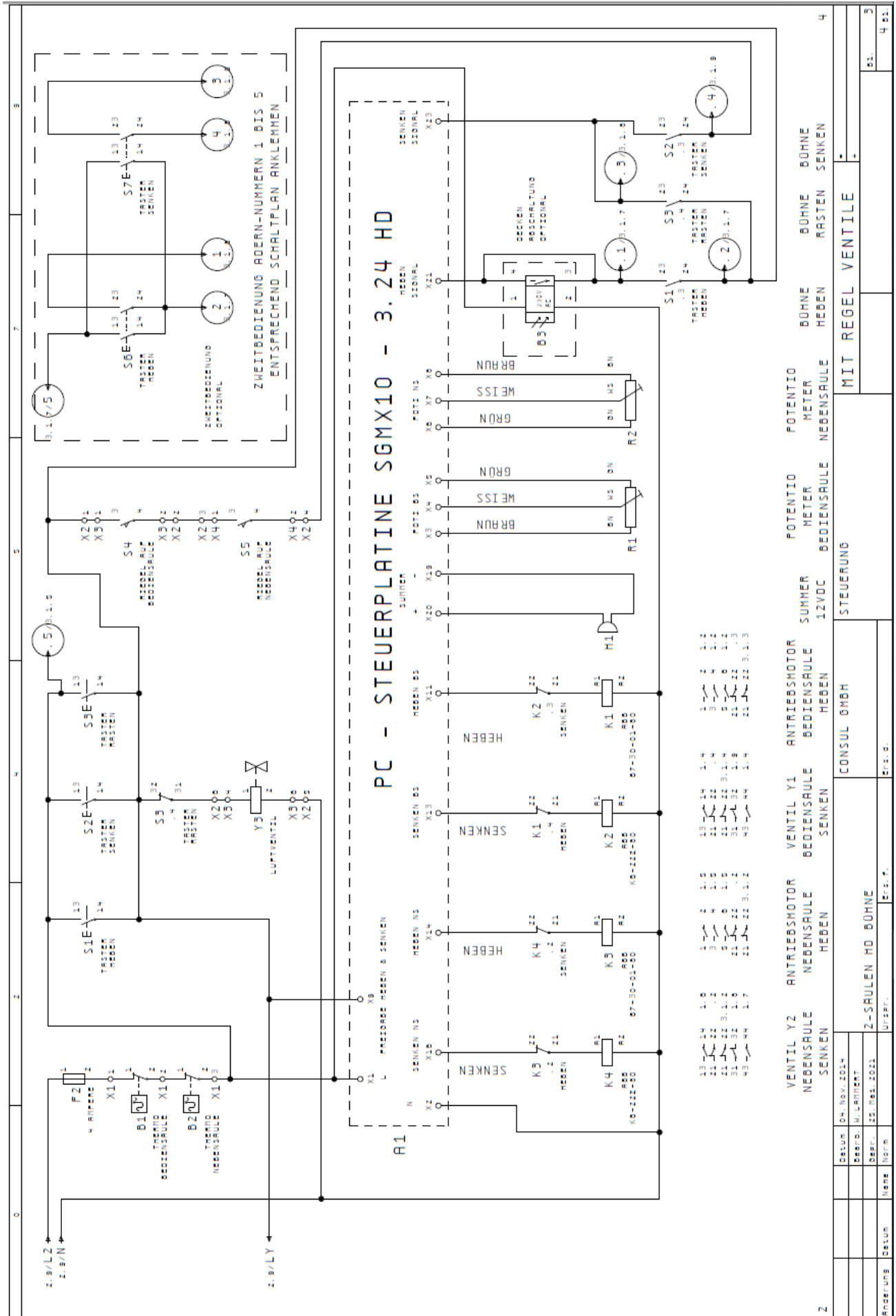

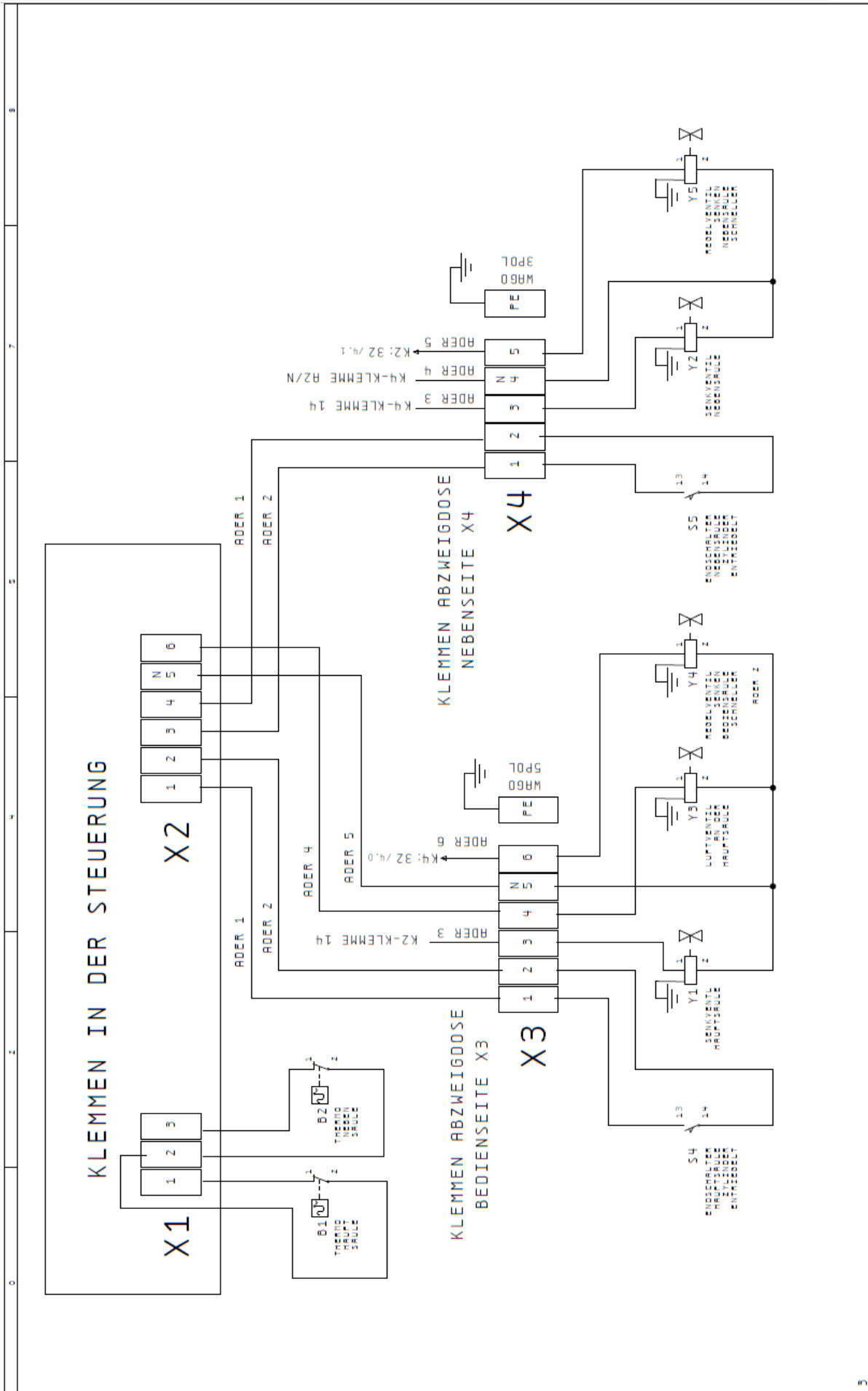

5		3		7		8	
Date: 25. Jun. 2015		Date: 25. Feb. 2011		Date: 25. Feb. 2011		Date: 25. Feb. 2011	
Drawn: M. Lehmann		Drawn: M. Lehmann		Drawn: M. Lehmann		Drawn: M. Lehmann	
Checked: M. Lehmann		Checked: M. Lehmann		Checked: M. Lehmann		Checked: M. Lehmann	
Approved: M. Lehmann		Approved: M. Lehmann		Approved: M. Lehmann		Approved: M. Lehmann	
Name: M. Lehmann		Name: M. Lehmann		Name: M. Lehmann		Name: M. Lehmann	
Position: Urspr.		Position: Urspr.		Position: Urspr.		Position: Urspr.	
Project: 2-SÄULEN HD BOHNE		Project: 2-SÄULEN HD BOHNE		Project: 2-SÄULEN HD BOHNE		Project: 2-SÄULEN HD BOHNE	
Company: CONSUL GMBH		Company: CONSUL GMBH		Company: CONSUL GMBH		Company: CONSUL GMBH	
Drawing: STEUERUNG		Drawing: STEUERUNG		Drawing: STEUERUNG		Drawing: STEUERUNG	
Sheet: 4 of 4		Sheet: 4 of 4		Sheet: 4 of 4		Sheet: 4 of 4	
Title: MIT REGEL VENTILE		Title: MIT REGEL VENTILE		Title: MIT REGEL VENTILE		Title: MIT REGEL VENTILE	
Description: HD-2 AGGREGATE		Description: HD-2 AGGREGATE		Description: HD-2 AGGREGATE		Description: HD-2 AGGREGATE	

Electric diagram (697797)

Um die Säulen einzeln fahren zu können, muss der Taster zur Einzelfahrt permanent gedrückt sein. Ist der Taster nicht gedrückt, fahren die Säulen immer zusammen.

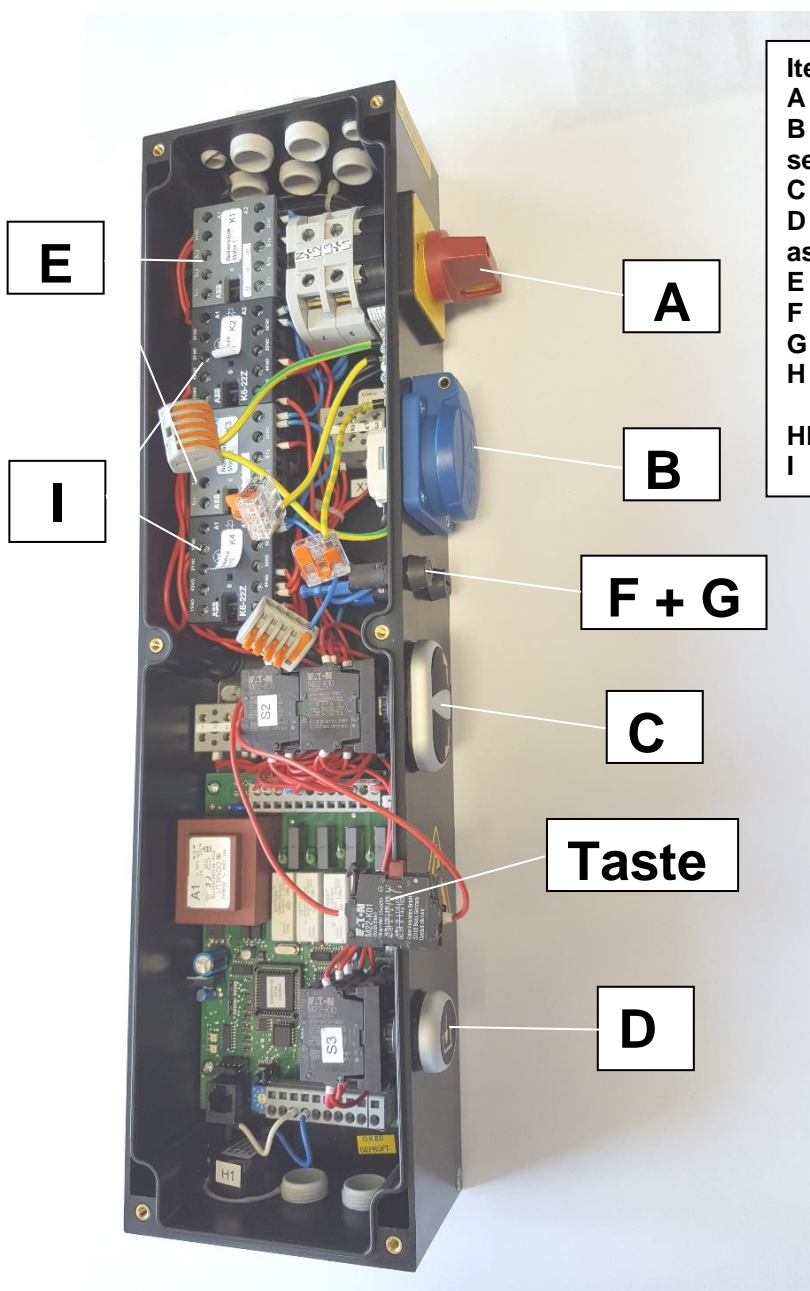

Item.	ID-number:	Description:
A	37055.1	Main switch
B	31602.6	Socket with seal
C	37056.9	Double switch assy.
D	37057.7	Push button
E	37496.7	Contactor
F	31897.2	Fuse 1A
G	31898.0	Fuse 6.3A
H	55015.2	Control board SGMX10 3.24-
HDMX10		
I	70450.2	Contactor

Pneumatic diagram

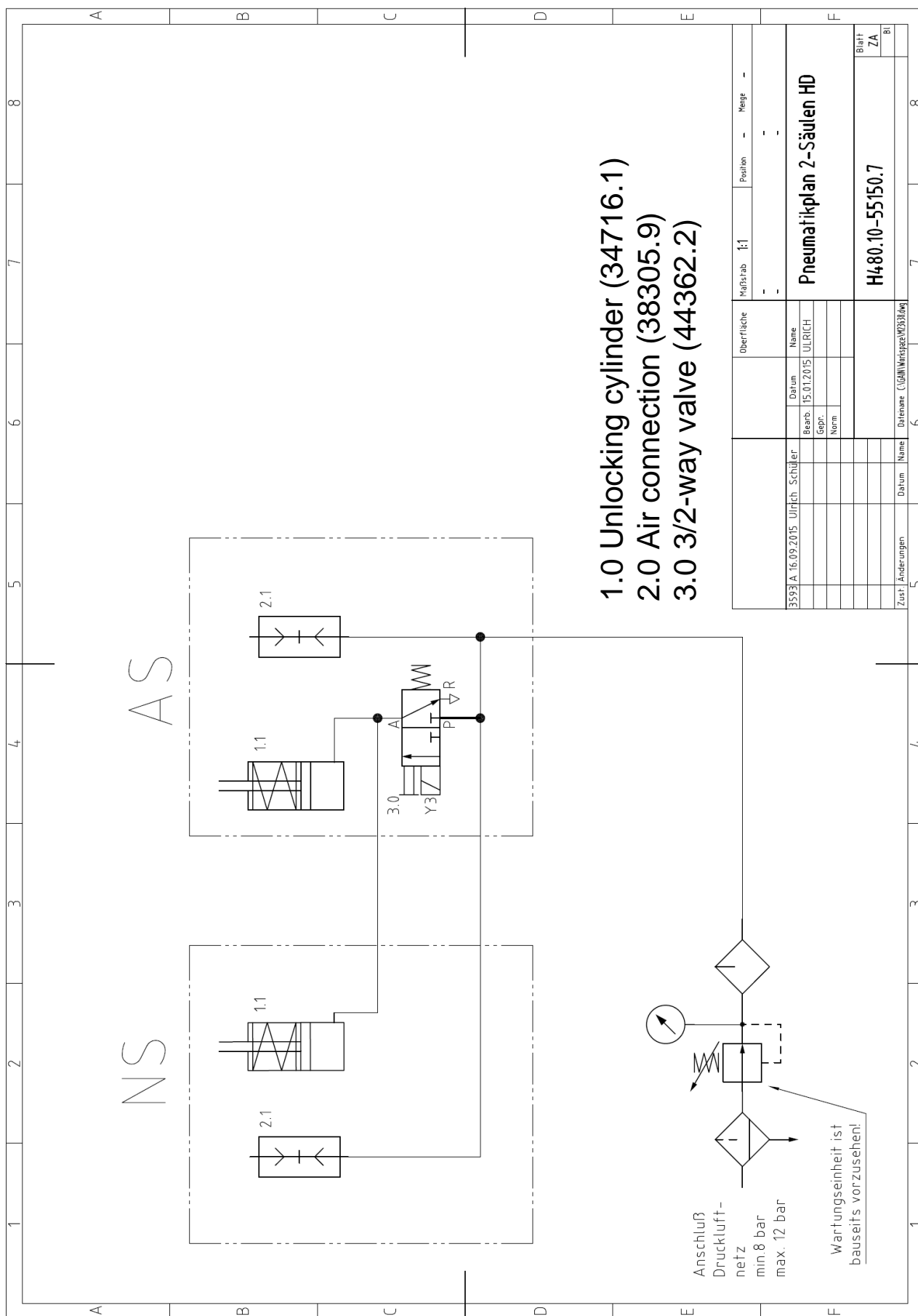

Pick up (raising) plate with socket

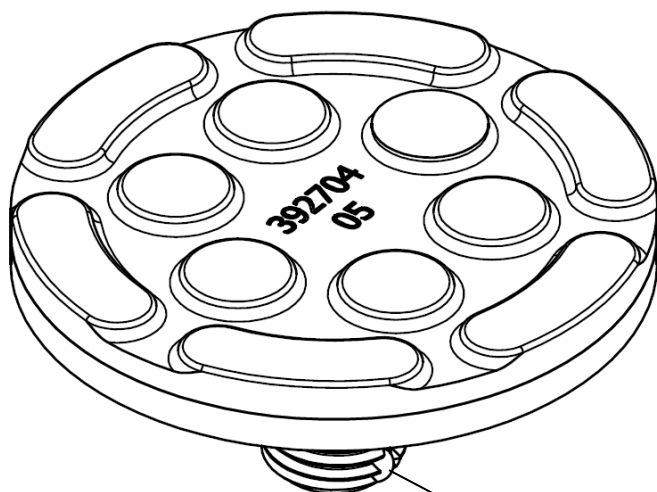

Socket
In a height of
35 mm or 75 mm(spare):
40602.5

Safety delimitation device from being pulled out

Subject to change without prior notice!

Pick up (raising) plate with socket up 4,5to

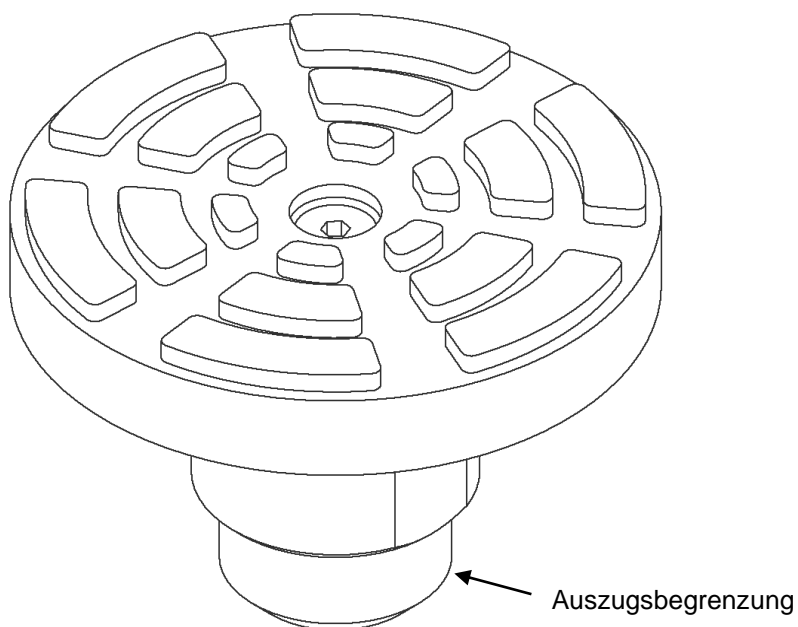

Subject to change without prior notice!

Assembly of the Lifting Arms and the Arm Locking Device

After fitting the lifting arms it is important that the tooth system of the catch latches and unlatches easily. The threaded bolt at the catch has to be adjusted in such a way that the catch is at least 2mm above the tooth system if the carriage is completely lowered.

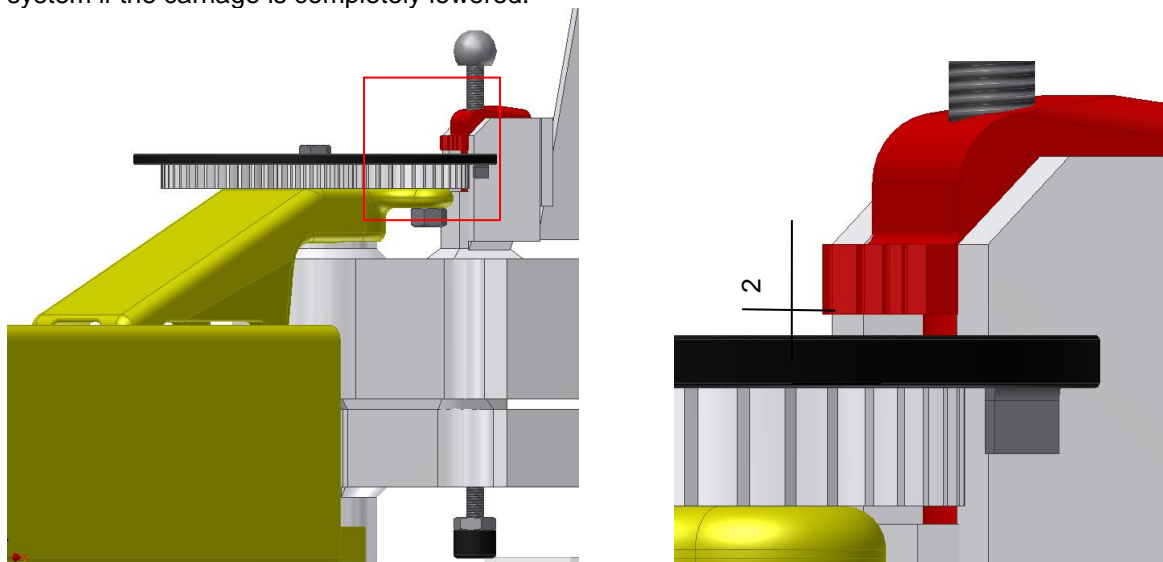

Cover of Locking Disc

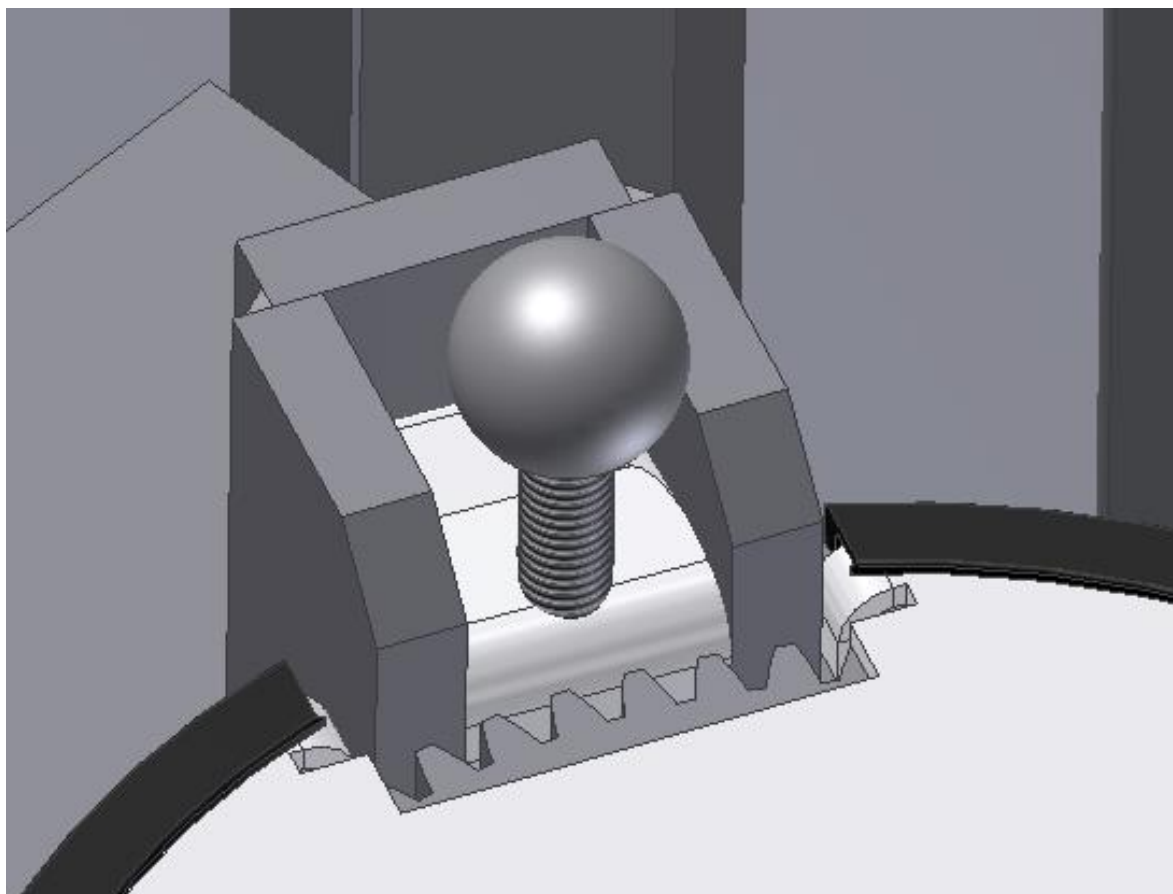

Consul FixLift

Height adjustable bearing arm system with multi-stage transmission device. Optionally available for Consul series H480.

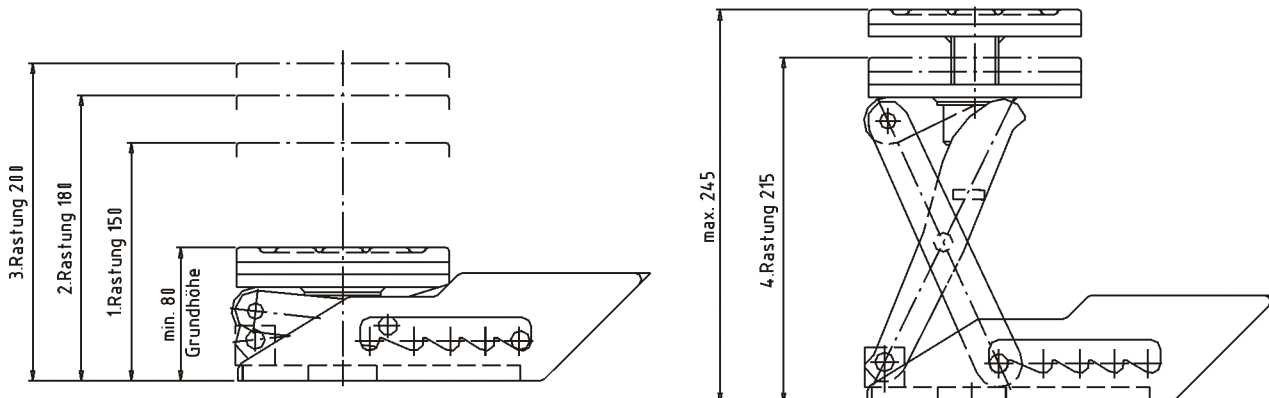

The decisive construction advantages:

- Pivot height min. 80mm
- Pivot height max. 245mm
- Ergonomic one-handle operation
- Integrated, height adjustable rotational plate (infinitely variable adjustment via 30mm).
- Vertical height adjustment without lateral displacement.

Warning:

When altering the fix lift, keep the free hand away from the fix lift mechanism (risk of injury).

Subject to change without prior notice!

Manual unlocking

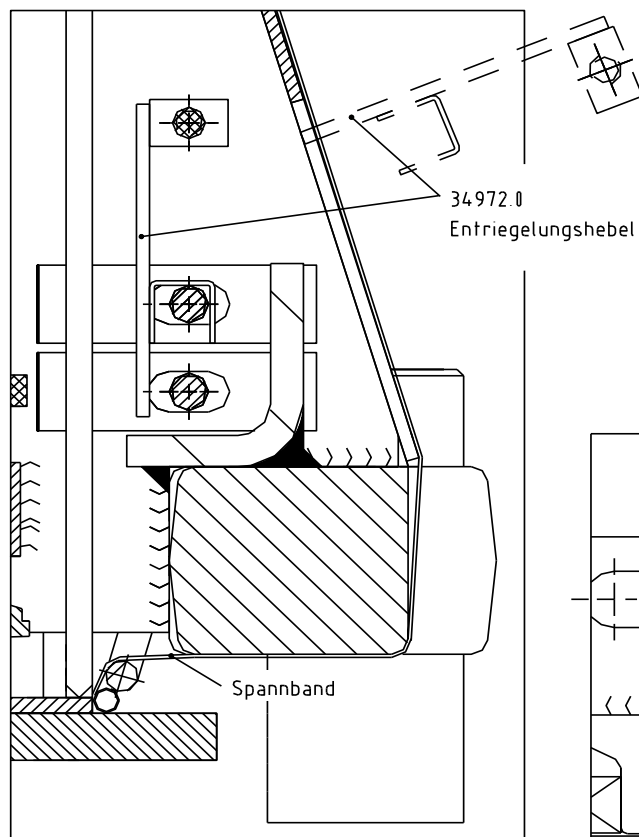

Accessories
Order no.: 34990.2

Manual of arm lock override

Remove cover tape, so that you can see the spindle.

Put the lever through the front of the hole of the carriage. The U-Profile have to set down on the first thread bar and then to tilt to the back.

Screw the ball grap on the guide rod (2x).

Screw in the guide rod now into the tapped hole of the lever 7 mm depth.

Now control the manual arm lock override.

Fasten the cover tape with the metal stripe and the nuts again.

Subject to change without prior notice!

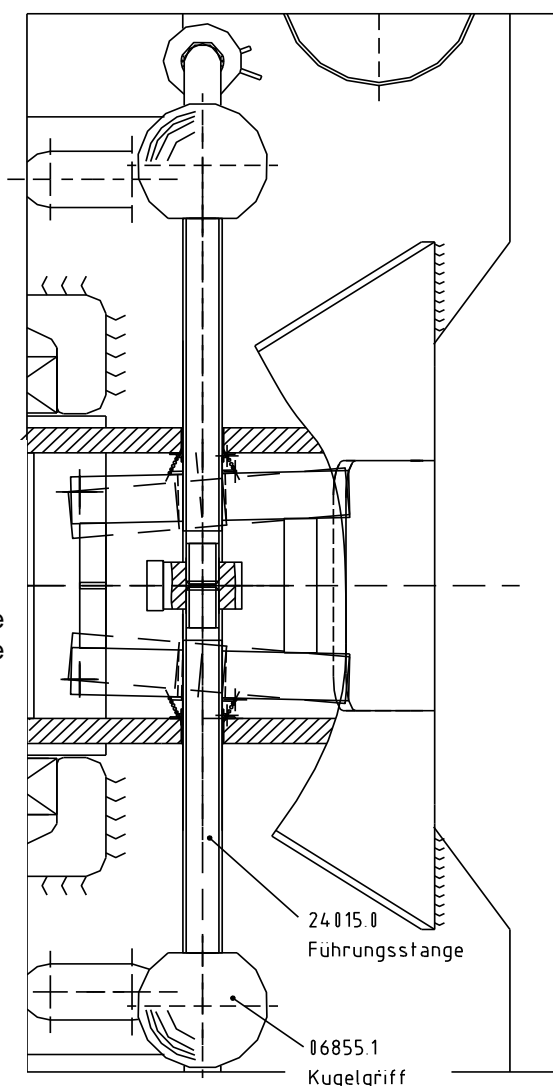

Faults and causes

If faults occur to the lifts, disconnect the power immediately, withdraw from operation, safeguard against unauthorized use and inform the Consul customer service department.
All repairs are only to be carried out by (correspondingly) trained persons.

Fault	Cause	Rectification
Different Rotation	potentiometer setting is not correct	Check the potentiometer value by qualified service center of the manufacturer
	Timing of the distance measuring system has twists	toothed belt untwist and possibly check potentiometer value by qualified service center of the manufacturer.
Lift does not lower	Power supply to the lift is broken and/or electrovalve does not switch	Check whether the electrical power supply and/or the electrovalve electrics are in order. Hire an electrician
	air supply to the lift is broken	Check if air line damaged or similar
	Latch firmly into the locking bars	Raise lift short so that the locking bars no longer sits in the latch.
Lift does not raise up	The power supply to the lift is broken and/or electrovalve does not switch.	Check whether the electrical power supply and/or the electrovalve electrics are in order. Checking the load current switch elements as well as the electric motor to see whether they work. Checking the main switch, control circuit and micro-fuse. . Hire an electrician
	Fittings not tight	Tighten fittings
	Pipe Leakage	. Replace the tube by qualified service center of the manufacturer.
	Toothed belt is broken.	toothed belt replaced by qualified service center of the manufacturer
Reciprocating piston compressor does not reach the full lifting height	If there is too little hydraulic oil	Check the oil level in the power unit, Fill up the oil.
Reciprocating piston compressor runs jerkily	Refilled with incorrect or non-recommended hydraulic-oil	Change oil
Reciprocating piston compressor does not run with the full load capacity	The electric motor only runs with 2 phases	Check the electric installations
	The overpressure valve is not properly adjusted	check pressure of the top piston setting, montage this manometer on the hydraulic unit (see the hydraulics plan)
	The hydraulic pump is faulty	For this, exchange the power unit. If the cause of the fault cannot be eliminated, please call Consul's customer service office.
Reciprocating piston compressor slowly lowers with load	Electrovalve does not close (sealed)	Clean the hydraulic system No remedy; Exchange the electrovalve through Consul's customer service office.
	Dirt in the hydraulic oil	Change oil
	Pressure relief valve is leaking	Turn on pressure relief valve until the lift is no longer sags.bis die Hebebühne nicht mehr absackt



	Check valve is leaking	Aggregate defective, replace
	Lowering valve is leaking	Replace lower valve
	Cylinder seal is leaking	Replace cylinder
Pivot arm locking device does not work.		Check the catches, check the pressure springs between the catches and the side wall of the jack lift, check the locking rods for a smooth fitting and/or lack of damage.

In the case of faults which go beyond the points listed above, consult the Consul customer service team. Repairs to Consul lifts should only be carried out by authorized customer service technicians.

Only original 'Consul spare parts' should be used as with the installation of the third party parts, the type approval and the warranty lose their validity.

Accident prevention regulations

According to the statutory accident prevention regulations of the commercial accident prevention and insurance association, the operator of lifts is required to:

start and run a log book for the lift.

test the lift before first use by an expert for its operational readiness review and enter the outcome of the test in the log book.

test the lift at regular intervals by an expert for a period lasting not longer than a year and enter the outcome of the test in the log book.

The sections listed above are excerpts, otherwise the corresponding test regulations is binding.

The required tests are correspondingly carried out by Consul's assembly services according to the specifications. Please ask Consul's sales associates for inexpensive maintenance contracts.

Service Manual

Before carrying out any work, the platform must be de-energized and secured against unauthorized use!

Under normal operating conditions in a standard location, maintenance must be carried out on an annual basis. Under above-average operating conditions, i.e. with more than 20 lift operations daily or use in open air, we recommend maintenance in 6-monthly intervals to ensure operating reliability and long service life.

According to VBG safety regulations, an annual safety check must be carried out.

Attention is to be paid to following points:

- All securing devices on bolts
- Play of stide bearings on each joint
- Roller guide ways and rollers
- All hydraulic lines and hoses
- Replace hydraulic noses every 6 years
- All connections for tight fitting and leaklightness
- Function of limit switces
- The condition of toothed belt and latches of locking device
- Cleanliness of piston rods
- Pressure relief valve must be set at 240 bar
- Change hydraulic fluid in sufficient quantity and check cleanliness
- Hydraulic level should be checked periodical (monthly) and refilled if necessary.
- Check quality and consistence regulary
- Interchange hydraulic oil completely when there are early changes of e.g. coloration, smell, milkyturbity, etc.. In occurrence of air blowing in hydraulic oil, please de-aerate. Attend to instructions and laws for handling of fluids hazardous to waters.
- All functions of control panel
- Conditions of pneumatic and electro conduction especially in area of joint
- Doweling
- Greasing of all joints and rollers

Important!

Refill hydraulic oil with same product. Do not mix up different sorts or brands.

WARNING!

ELIMINATE ALWAYS USED BRAKE FLUID TO POSSIBLE DAMAGE TO THE SURFACE TO AVOID. DISPOSAL OF USED OIL. Dispose of the used oil in accordance with the guidelines and laws of the country in which the lift is operated.

Order of Spare Parts

When ordering spare parts must be specified :

- Type Number and Year of construction of the lift
- Item Number oft he spare part (see spare parts lists)
- Quantity

The order must be addressed to the authorized resellers listed on the front page of this manual!

Cleaning, care and maintenance instruction

All visible paint spillings are to be mended by the installer after installing the hydraulic lift.

The lift is only to be cleaned using water with small additives of neutral or slightly alkaline detergent. Parts can be scrubbed with cloths or sponges. Please avoid hard scrubbing. The maximum application time of the detergent should not take longer than one hour.

The water temperature should not rise above 25°C. Immediately rinse off the parts with clear water after the cleaning process.

A preservation e.g. with commercially available body-cavity sealing (transparent) can offer additional protection to the coating. Capillaries, that can be found on every surface coating can be closed off by these preservatives. The preservation should be applied to each and every spot that has open edges or shows wetness. Except for the topside of the driving rail.

Attention!

- Don't use solvents that contain ester, ketone, alcohol or alkyl halides.
- Don't use any scratching abrasives.
- Don't use any acidic or strong alkaline detergents and surface-active.
- The detergents can only show 25°C max. Don't use steam injectors.
- The surface temperature of the parts being cleaned should not go above 25°C either.

The time intervals for cleaning and preservation are dependent on the environmental stress.

We recommend cleaning of critical parts (drip edges, heavy contamination or wetness) over a period of 4 to 6 weeks with preservation afterwards. It should be conducted by an installer during the standard maintenance intervals at the latest

Paint damages are to be whetted with sandpaper and mended with the appropriate RAL – colour during the maintenance intervals.

Ultimately preservation and cleaning preserves the optical appearance of the hydraulic lift and both measures contribute to saving consequential costs.

Spare parts lists H458.10 / H480.20 / H495.10

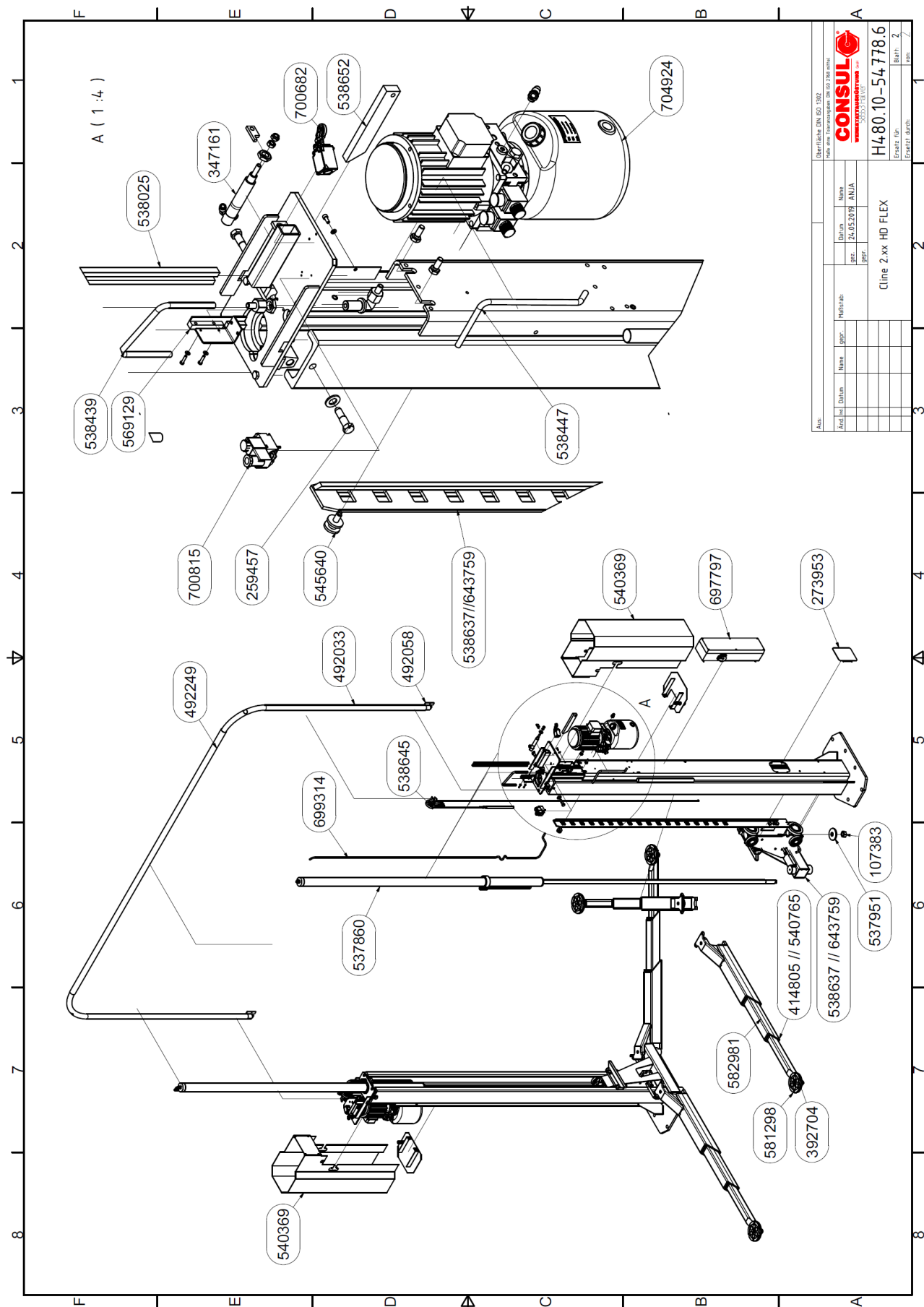

Überflische DIN ISO 1592 Maßstab für den Maschinenbau nach DIN 1592 CONSUL www.consul-maschinenbau.de 30553 TELFORD		Blatt: 2 von: 2
Name: _____ Datum: _____ gepr.: 24.05.2019 ANJA	Maßstab: _____ Blatt: _____ von: _____	H480.10-54.778.6 Cline 2-xx HD FLEX

Spare Parts list until 4,5 to HD FLEX

2.35 HD-FLEX	2.40 HD-FLEX	2.45 HD-FLEX		
Ident-Nr.:	Ident-Nr.:	Ident-Nr.:	BESCHREIBUNG	Description
107383	107383	107383	6kt-Mutter M24x2-8, DIN985 verzinkt	hexagon nut M24x2 - 8 DIN985 galvanized
259457	259457	259457	Paßschraube kpl.	Fitting screw
273953	273953	273953	Deckplatte	cover plate
347161	347161	347161	Entriegelungszyylinder + Winkel	Unlocking cylinder with angle
392704	392704		Aufnahmeteller kpl.	Support plate bis 4t
414805			Teleskopschwenkarm 2.35	Telescopic swivel arm 2.35
492033	492033	492033	Verbindungsrohr 92°	Connecting pipe 92°
492058	492058	492058	Befestigungsglasche kpl.	Fastening tab
492249	492249	492249	Verbindungsrohr 2505 lang	Connecting pipe 2505 mm
537860	537860	537860	Hydraulik-Zylinder, 50x25x1847 Hub	Hydraulic-cylinder, 50x25x1847 stroke
537951	537951	537951	Kugelscheibe	spherical disk
538025	538025	538025	Führungsleiste 450mm lg.	Guide bar 450 mm
538447	538447	538447	Hydraulik Rohr 2,vz.	Hydraulic pipe 2 galvanized
538637	538637		Hubwagen kpl. mit Absetzstange	Carriage with settling rod
538645	538645	538645	Wegmesssystem-Set H480.10	Distance measuring system
538652	538652	538652	Schieber Absetzeinrichtung,verz.	slider settling device
540369	540369	540369	Abdeckung	Cover
545640	545640	545640	Führungsrolle kpl. f. Absetzstange	Guide roller for settling bar
569129	569129	569129	Führungsleiste 2	Guide bar 2
697797	697797	697797	Steuerung HD-Bühne, neu ab 07/20	control box HD-Lifts new from 07/20
699314	699314	699314	PU-Schlauch	PU-tube
700682	700682	700682	Endschalter mit Rolle kpl.	Limit switch with roller
700815	700815	700815	3/2-Wege-Ventil kpl.	3/2-Way Valve
704924	704924	704924	Aggregat,HD-Bühne mit 5 L Tank	Hydraulic unit with 5Liter tank
	540765		Teleskopschwenkarm 2.40	Telescopic swivel arm 2.40
		581298	Aufnahmeteller kpl. 5t	Support plate 5t
		582981	Teleskopschwenkarm 2.45	Telescopic swivel arm 2.45
		643759	Hubwagen kpl. mit Absetzstange Spannband	Carriage with settling rod

Subject to change without prior notice!
Stand: 10/2020

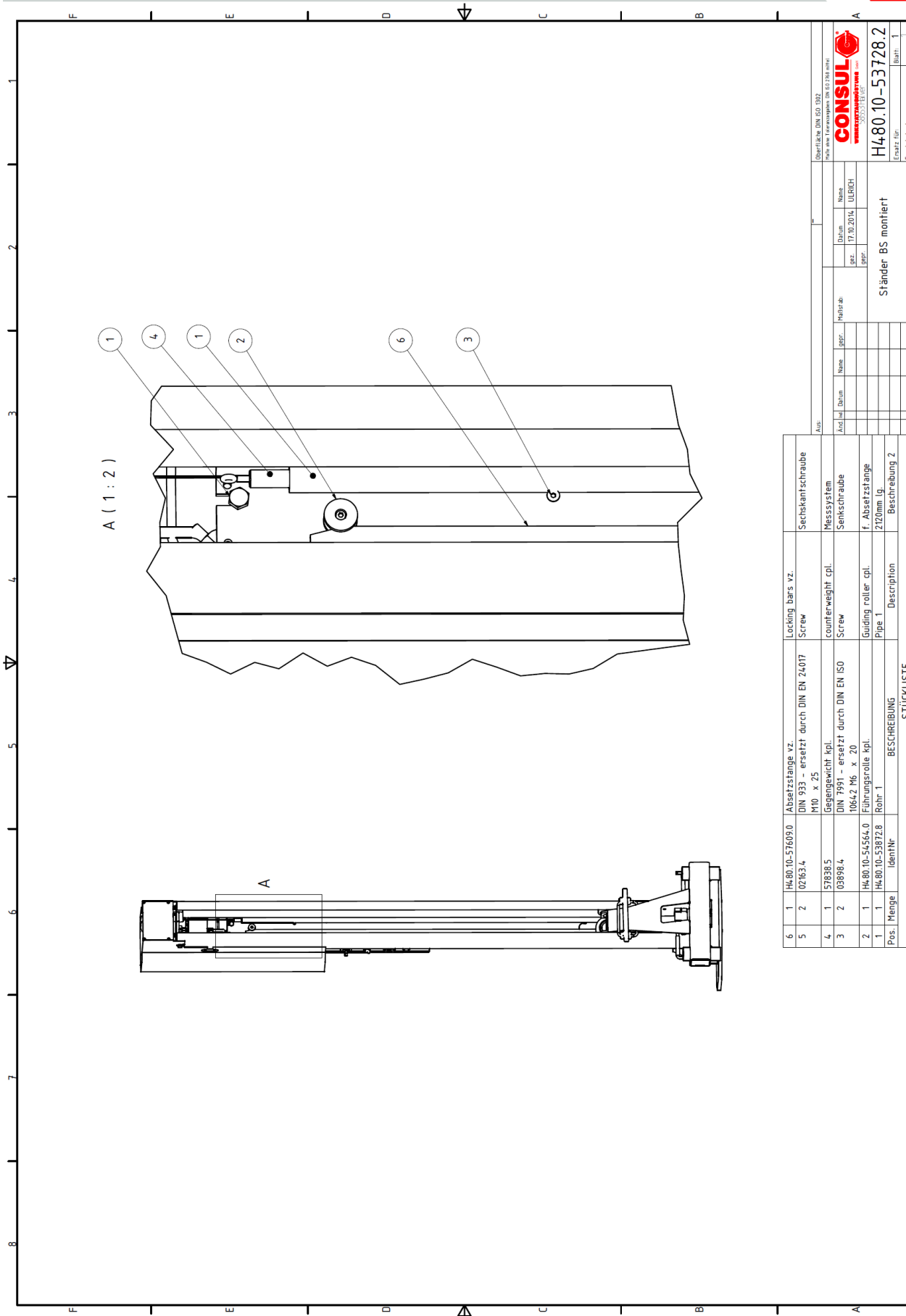

Pos.	Menge	IdentNr	BESCHREIBUNG	Description
1	1	Hk.80-54564.0	Führungsrolle kpl.	Guiding roller cpl.
2	1	Hk.80-54564.0	f. Absetzstange	f. Absetzstange
3	1	Hk.80-53872.8	Rohr 1	Pipe 1
4	1	Hk.80-53872.8	BESCHREIBUNG	Description
5	1	Hk.80-57609.0	Absetzstange vz.	Locking bars vz.
6	1	Hk.80-57609.0	DIN 933 - ersetzt durch DIN EN 24017	Screw
7	1	02763.4	M10 x 25	Sechskantschraube
8	1	57895.5	Gegengewicht kpl.	Messsystem
9	2	03895.4	DIN 7991 - ersetzt durch DIN EN ISO 1064.2 M6 x 20	Senkschraube

Überf. l. Nr. 01. 392.
 Nach dem Freigeben des BS durch den

CONSUL
 WERKZEUGE FÜR DIE BAUINDUSTRIE

17.10.2014 ULRICH

H480.10-53728.2

Ständer BS montiert

Erstellt Durch: []
 Blatt: 1 von 1

Spare Parts list 537282

Pos.	Qty	Item No.:	BESCHREIBUNG	Description
1	1	538728	Rohr 1 Länge: 2120 mm	Pipe 1 Length: 2120 mm
2	1	545640	Führungsrolle kpl. für Absetzstange	Guiding roller cpl. for locking bar
3	2	038984	Senkschraube DIN 7991 - M6 x 20	Screw DIN 7991 - M6 x 20
4	1	578385	Gegengewicht kpl.	counterweight cpl.
5	2	021634	6kt-Schraube DIN 933 - M10 x 25	Screw DIN 933 - M10 x 25
6	1	576090	Absetzstange vz.	Locking bars vz.

Subject to change without prior notice!

Stand: 10/2020

537878 Hubwagen

538637 Hubwagen mit Absetzstange

13	1	H400.10-537878.4	Kugelgarnitur
12	1	019778	Türanschlag
11	4	900000	Kegelrolle
10	2	363403	Arretierflache
9	4	XXXX.00-10000.0	Kegeltrieb
8	2	1005.00-26180.3	Arretierflache
7	2	0000.00-16176.7	Arretierflache
6	2	XXXX.00-27353.2	Sechskantmutter M2x1
5	2	9300.00-44208.7	Arretierstange-Verstärkung
4	4	0000.00-40449.7	Lauffolie
3	2	0000.00-21067.2	Lauffolie LR 21i KDUJ An04
2	2	9300.00-42844.6	Rohrabschlussdeckel
1	1	H400.10-537878.6	Hubwagen

Pos.	Menge	IDENTIF.	BESCHREIBUNG	MATERIAL
STÜCKLISTE				
Gew.		137,208 kg		
Überfläche: DIN ISO 1952				

5	1	533077	Überschubbe M6
4	2	179077	DIN 933 - ersetzt durch DIN EN 24017 M2 x 25
3	2	125203	DIN 127 - zurückgezogen A 12
2	1	H400.10-537878	Hubwagen typ. H400 45055.1
1	1	H400.10-576090	Absetzstange vz.

Pos.	Menge	IDENTIF.	BESCHREIBUNG	MATERIAL
STÜCKLISTE				
Gew.		137,208 kg		
Überfläche: DIN ISO 1952				

H400.10-538637
Hubwagen
mit Absetzstange

Seite 1
von 1

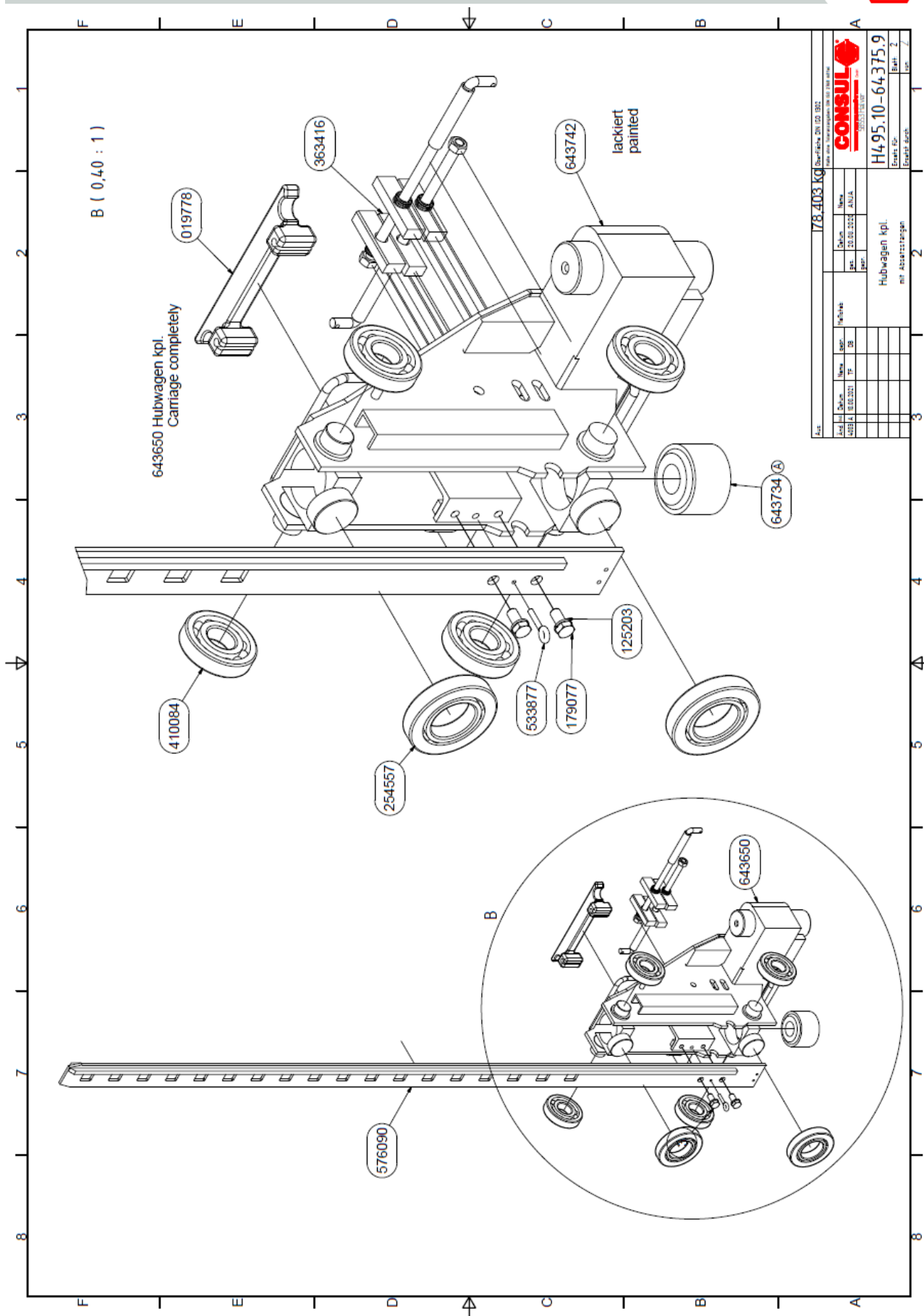

Spare Parts list carriage 538637

Qty	Item No.:	BESCHREIBUNG	Description
1	576090	Absetzstange verzinkt	Settling bar, galvanized
1	537878	Hubwagen	Carriage
2	125203	Federring DIN 127 - A 12	Spring washer
2	179077	6kt-Schraube DIN 933 - M12 x 25	Hexagon screw DIN 933 M12x25
1	533877	Ösenschraube M6	Eyebolt M6

Subject to change without prior notice! Stand: 10/2020

Spare parts Carriage 537878

Qty	Ident-Nr.:	BESCHREIBUNG	Description
2	420646	Rohrabschlussdeckel	Pipe end cover
2	210872	Satz-Laufrolle LR 211 KDDU AH04	Set of Rollers
4	401497	Satz-Laufrolle	Set of Rollers
2	363416	Arretierung	Locking device
1	019778	Türanschlag	Door stop
1	537944	Kugelpfanne	Ball pan

Subject to change without prior notice! Stand: 09/2021

Spare parts Carriage 643759 for 4,5 to

Menge	IdentNr	BESCHREIBUNG	Description
1	576090	Absetzstange vz.	Settling bar, galvanized
1	643650	Hubwagen kpl.	Carriage
2	125203	Federring DIN 127 - A 12	Spring washer
2	179077	6kt-Schraube DIN 933 - M12 x 25	Hexagon screw DIN 933 M12x25
1	533877	Ösenschraube M6	Eyebolt M6
1	643734	Kugelpfanne	Ball pan

Subject to change without prior notice! Stand: 09/2021

Spare parts Carriage 643650 for 4,5 to

Menge	Ident-Nr.:	BESCHREIBUNG	Description
2	210872	Satz-Laufrolle LR 211 KDDU AH04	Set of Rollers
4	401497	Satz-Laufrolle	Set of Rollers
2	363416	Arretierung	Locking device
1	019778	Türanschlag	Door stop
1	643742	Hubwagen lackiert	Carriage painted
1	643734	Kugelpfanne	Ball pan

Subject to change without prior notice! Stand: 09/2021

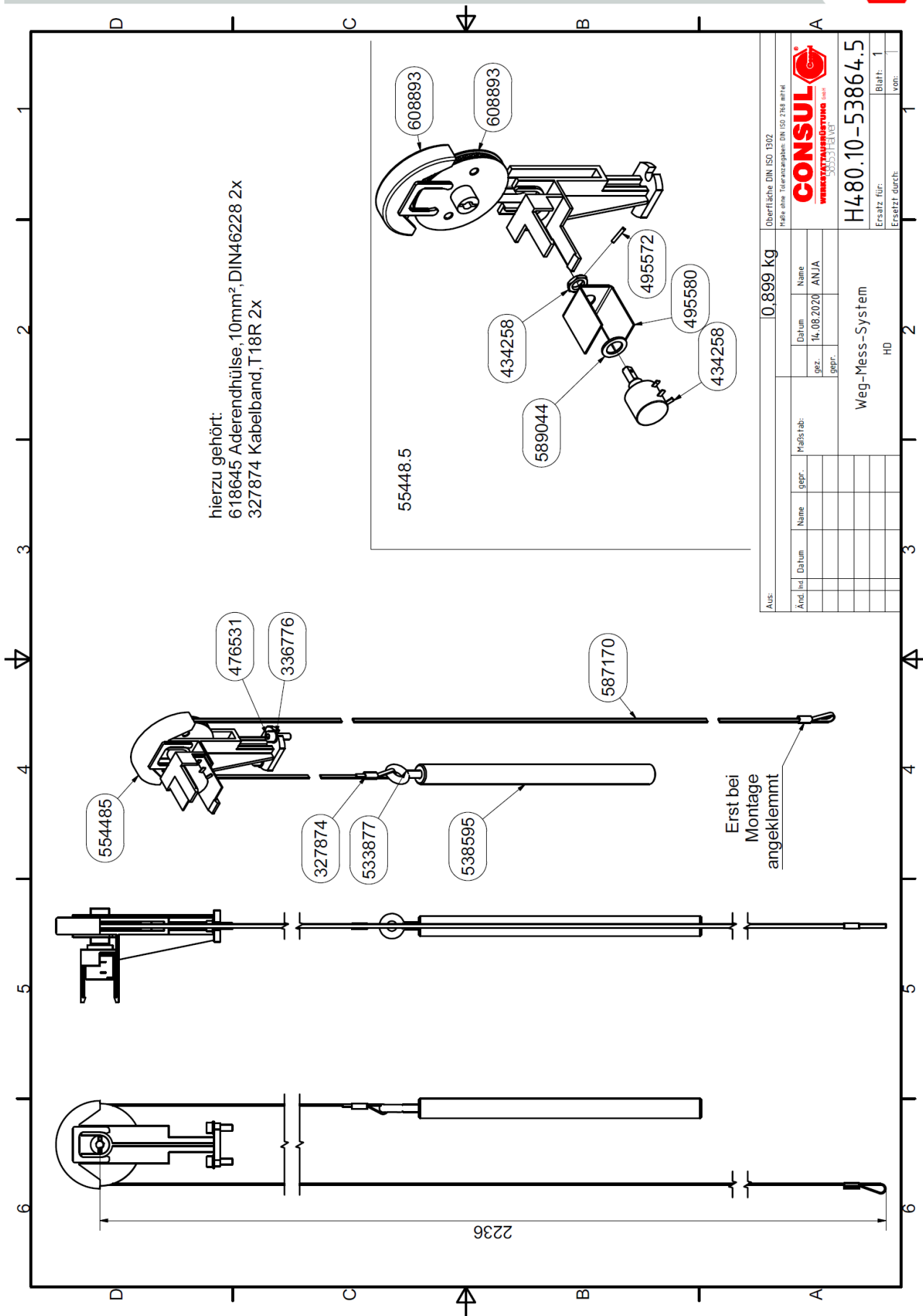

Spare parts list 538645

Pos.	Qty	Item No.:	BESCHREIBUNG	Description
1	1	554485	Umlenkrolle + Poti montiert	Deflector roller and potentiometer mounted
2	1	587170	Zahnriemen	Timing belt
3	1	538595	Gegengewicht	Counterweight
4	1	533877	Ösenschraube M6	Eyebolt M6
5	2	476531	Zyl-Schraube	Socket head screw
6	2	336776	Scheibe DIN 125-1 A A 5,3	Washer
7	2	327874	Aderendhülse	Ferule

Subject to change without prior notice!

Stand: 10/2020

Spare parts list 554485

Pos.	Qty	Item No.	BESCHREIBUNG	Description
1	1	608893	Potihalter kpl.	Pot holder cpl.
3	1	495572	Befestigungsstift Potii	Fixing pin
4	1	495580	Befestigungsblech	Mounting plate
6	1		Potimutter	Nut
7	1	434258	Potentiometer 10kOhm	Potentiometer
8	1		Stützscheibe DIN 988 S11 x 17	Support washer

Subject to change without prior notice!

Stand: 10/2020

Spare parts drawing ab 5 to HD FLEX

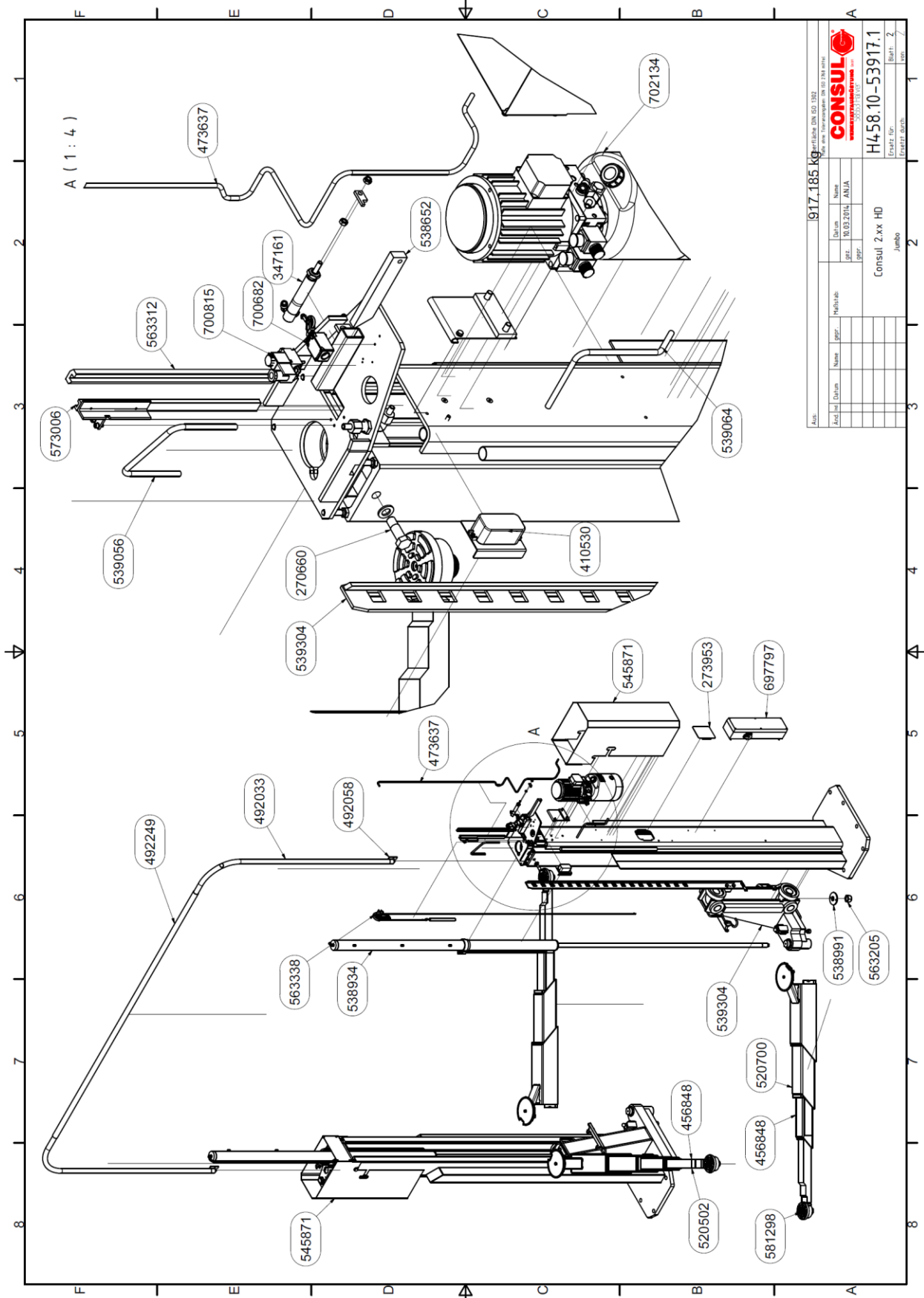

Art-Nr.		917,185 kg		Zertifizierte DIN ISO 15025	
Zust.		Name		CONSUL	
Zust.		Date		10.03.2014	
Zust.		Name		ANJA	
Zust.		Name		Jumbo	
Zust.		Name		Consul 2.xx HD	
Zust.		Name		H458.10-53917.1	
Zust.		Name		Ersatz für	
Zust.		Name		Blatt: 2	
Zust.		Name		von: 7	

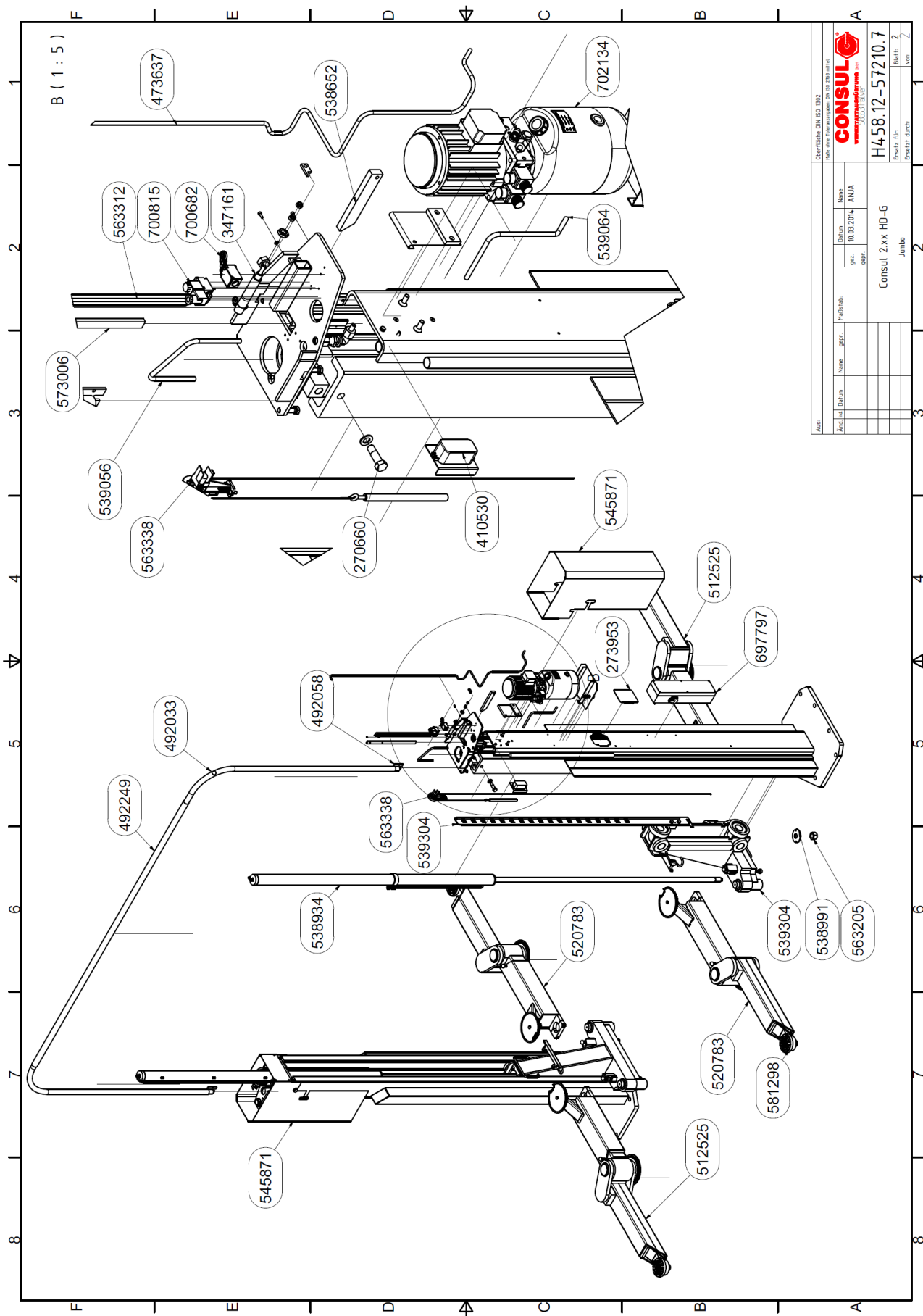

Identifizierung: DIN ISO 1592 Maßstab: 1:5 CONSUL www.consul.com 50533 13 100		Name: ANJA Datum: 10.03.2014 gezeichnet: ANJA geprüft:	
Art:		H4-58.12-57210.7 Ersatz für: Blatt: 2 Gesamtzahl: von: 2	
Anzahl:		Consul 2.xx HD-G Jumbo	

Spare parts list up 5 to HD FLEX

2.55 HD-FLEX	2.55 HD-G FLEX	2.65 HD-FLEX	2.70 HD-FLEX		
Item No.:	Item No.:	Item No.:	Item No.:	BESCHREIBUNG	Description
563205	563205	563205	563205	6kt-Mutter DIN985 M30x2,vz.	hexagon nut M30x2 - 8 DIN985 galvanized
270660	270660	270660	270660	Paßschraube kpl. DIN610 M16x55,vz.	Fitting screw
273953	273953	273953	273953	Deckplatte,schwarz	cover plate
347161	347161	347161	347161	Entriegelungszyylinder + Winkel	Unlocking cylinder with angle
410530	410530	410530	410530	Kleinstgehäuse	Control box
492033	492033	492033	492033	Verbindungsrohr 92°	Connecting pipe 92°
492058	492058	492058	492058	Befestigungslasche kpl.	Fastening tab
492249	492249	492249	492249	Verbindungsrohr 2505 lang	Connecting pipe 2505 mm
538991	538991	538991	538991	Kugelscheibe (M30x2)	Spherical disk (M30x2)
563312	563312	563312	563312	Führungsleiste 450mm lg.	Guide bar 450 mm
539304	539304	539304	539304	Hubwagen mit Absetzstange	Carriage with settling rod
563338	563338	563338	563338	Wegmesssystem-Set	Distance measuring system
538652	538652	538652	538652	Schieber Absetzeinrichtung	slider settling device
545871	545871	545871	545871	Abdeckung	Cover
573006	573006	573006	573006	Führungsleiste 2	Guide bar 2
697797	697797	697797	697797	Steuerung HD-Bühne, neu ab 07/20	Control box HD-Lifts new from 07/20
473637	473637	473637	473637	PU-Schlauch	PU-tube
700682	700682	700682	700682	Endschalter mit Rolle kpl.	Limit switch with roller
700815	700815	700815	700815	3/2-Wege-Ventil kpl.	3/2-Way Valve
702134	702134	702134	702134	Aggregat,HD-Bühne mit 7 L Tank	Hydraulic unit with 7 Liter tank
581298	581298	581298	581298	Aufnahmeteller kpl. 5t	Support plate 5t
456848				Teleskopschwenkarm 2.55	Telescopic swivel arm 2.55
		520700	520700	Teleskopschwenkarm 2.65/2.70 rechts	Telescopic swivel arm 2.65/2.70 right
		520502	520502	Teleskopschwenkarm 2.65/2.70 links	Telescopic swivel arm 2.65/2.70 left
	512525			Gelenkarm 2.55 links	Articulated swivel arm 2.55 left
	520783			Gelenkarm 2.55 rechts	Articulated swivel arm 2.55 right
538934	538934	538934	538934	Hydraulik Zylinder 60x30- 1825 HUB	Hydraulic- cylinder,60x30x1825 stroke

Subject to change without prior notice!
Stand: 10/2020

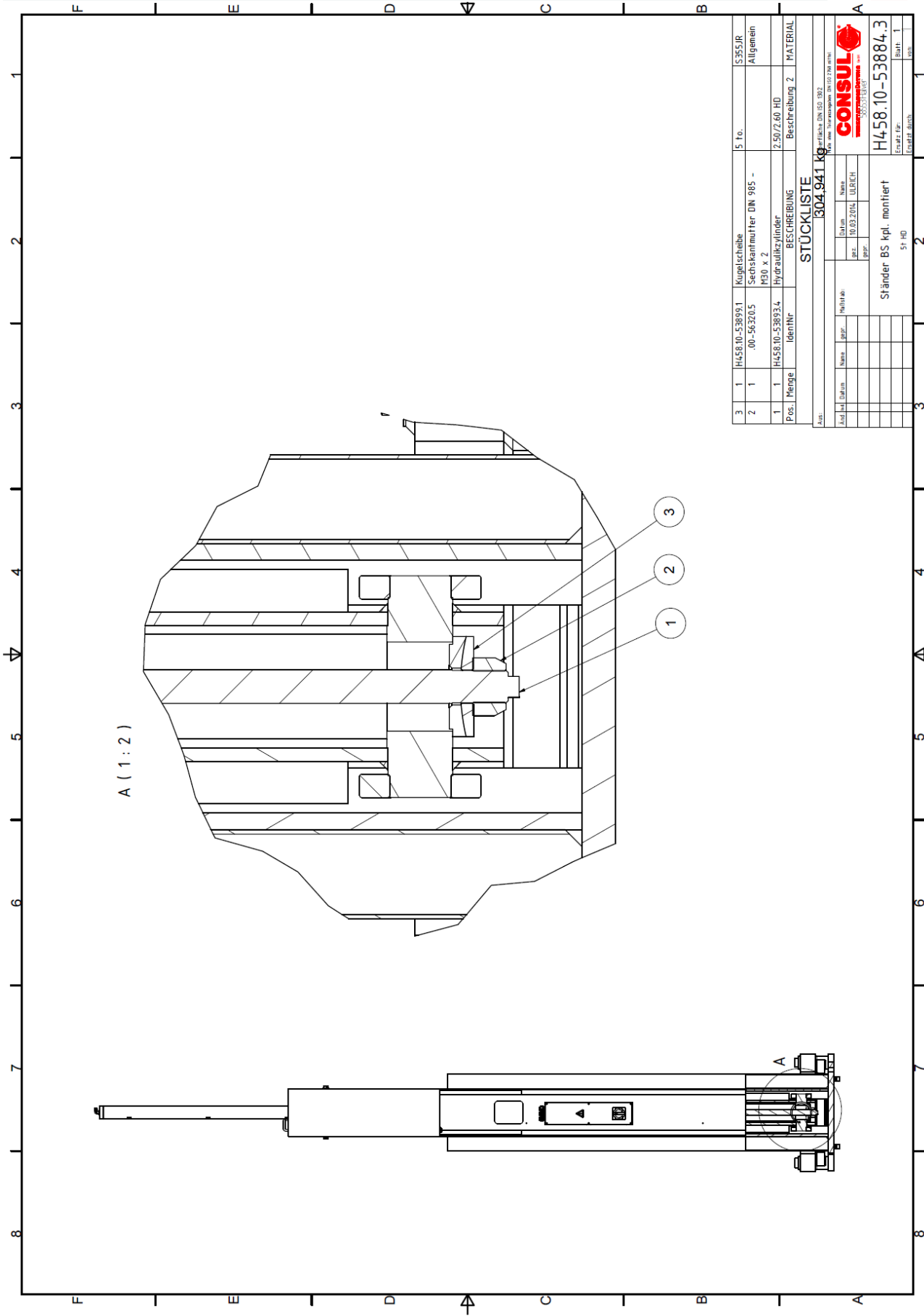

Pos.	Menge	Ident.Nr.	BESCHREIBUNG	Beschreibung 2	MATERIAL
3	1	H458.10-53895.1	Kugelscheibe		5385JR
2	1	.00-563205	Sechskantmutter DIN 985 - M30 x 2		Allgemein
1	1	H458.10-53893.4	Hydraulizylinder	2.50/2.60 HD	
STÜCKLISTE					
304.941 kg					
Art.Nr. H458.10-53893.4					
H458.10-53884.3					
Ständer BS kpl. montiert					
51 HD					
Erstellt: T...					
Geprüft: B...					
Blatt: 1					
von: 1					

Spare part list 538843 page 1

Pos.	Qty.	Item No.:	BESCHREIBUNG	Beschreibung 2
1	1	538934	Hydraulikzylinder	Hydraulic cylinder
2	1	563205	Sechskantmutter DIN 985 - M30 x 2	Hexagon Nut
3	1	538991	Kugelscheibe	Spherical disk

Subject to change without prior notice!

Stand: 10/2020

Spare Parts drawing carriage 5t with settling bar 539304

12	2	107441	DIN 125-1 A A 6.4	Unterienscheibe	
11	2	467902	DIN 912 -- ersetzt durch DIN EN ISO L762 M6 x 12	Zylinderkopfschraube	
10	1	H458.10-56332	Bereifungsblech Zahnriemen		
9	1	H480.10-57609	Absetztange vz.		
8	2	125203	DIN 127 - zurückgezogen A 12	Federring	
7	2	179077	DIN 933 - ersetzt durch DIN EN 24.01T M12 x 25	Sechskantschraube	
6	2	270066	DIN 472.110 x 4	Sicherungsring	
5	2	H460.00-51573	Sperbolzen Anruehrung	Kpl.	
4	1	H05.00-01977.8	Türanschlag	019778	
3	2	0000.00-26984	Führungsring	Türanschlag 269845	
2	6	0000.00-21087	Lauffrolle	Führungsring 210872	
1	1	H458.10-53880	Hubwagen HD 5t		
Pos.	Menge	IdentNr	BESCHREIBUNG	Beschreibung 2	MATERIAL
STÜCKLISTE					
Aus:				179.292 kg	
Überfläche DIN ISO 1392					
Datei aus: Carriage 5t (DIN 120 min)					
And. he	Datum	Name	post.	Dr/Len	Name
			post.	08.09.2021	ANJA
			post.		
				Hubwagen kpl. 5t HD	
				H458.10-53930.4	
				Erstellt für: _____	
				Erstellt durch: _____	
				Blatt: 2	
				von: 2	

Spare Parts Lifting carriage 5t with settling bar 539304

	Pos.	Qty	Item No.:	BESCHREIBUNG	Description
	1	1	538801	Hubwagen HD 5t	Carriage HD 5t
	2	6	210872	Laufrolle	Roller
	3	2	269845	Führungsring	Guide ring
	4	1	019778	Türanschlag	Doorstop
*	5	2	515734	Sperrbolzen Arretierung	Locking pin
	6	2	270066	Sicherungsring DIN 472 110 x 4	Safety spring DIN 472 110 x 4
	7	2	179077	Sechskantschraube DIN 933 - M12 x 25	Hexagon screw DIN 933 - M12 x 25
	8	2	125203	Federring DIN 127 - A 12	Spring washer DIN 127 - A 12
	9	1	576090	Absetzstange vz.	Settling bar
	10	1	563320	Befestigungsblech Zahnriemen	Mounting plate for toothed belt
	11	2	467902	Zylinderkopfschraube DIN 912 - M6 x 12	Cylinderhead screw DIN 912 - M6 x 12
	12	2	107441	Unterlegscheibe DIN 125-1 A A 6,4	Washer DIN 125-1 A A 6,4

Subject to change without prior notice!

Stand: 10/2020

*Arm locking assemblies:

	Z240 / H331.01	44450.5	H476	Z256-Z258
	2.55 / 2.65	2.50	Consul 2.50-G	
	Tragarme	Mit Radgreifer	Mit Gelenkarme	Mit Schuh
detent rod length	200	+40 mm	+40 mm	+40 mm
Item-No.:	515734	577791	577791	577791

Subject to change without prior notice!

Stand: 10/2020

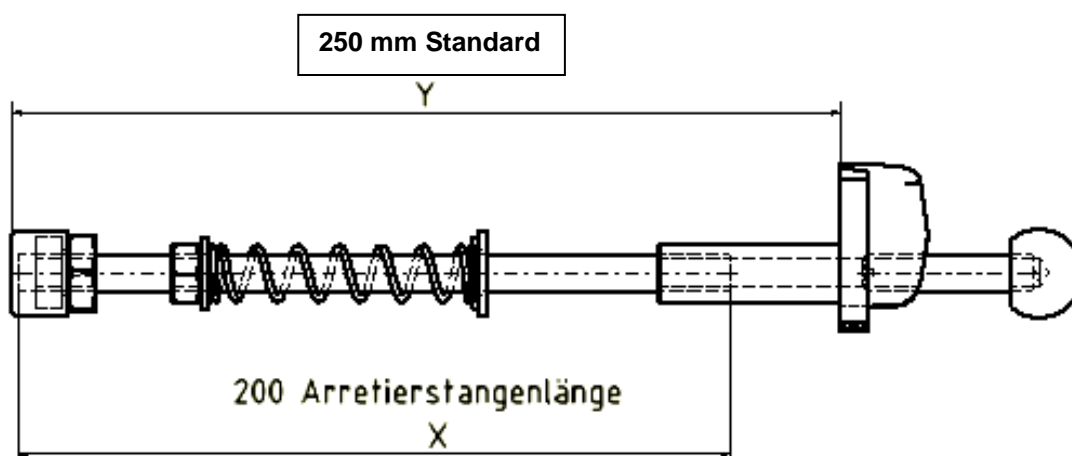

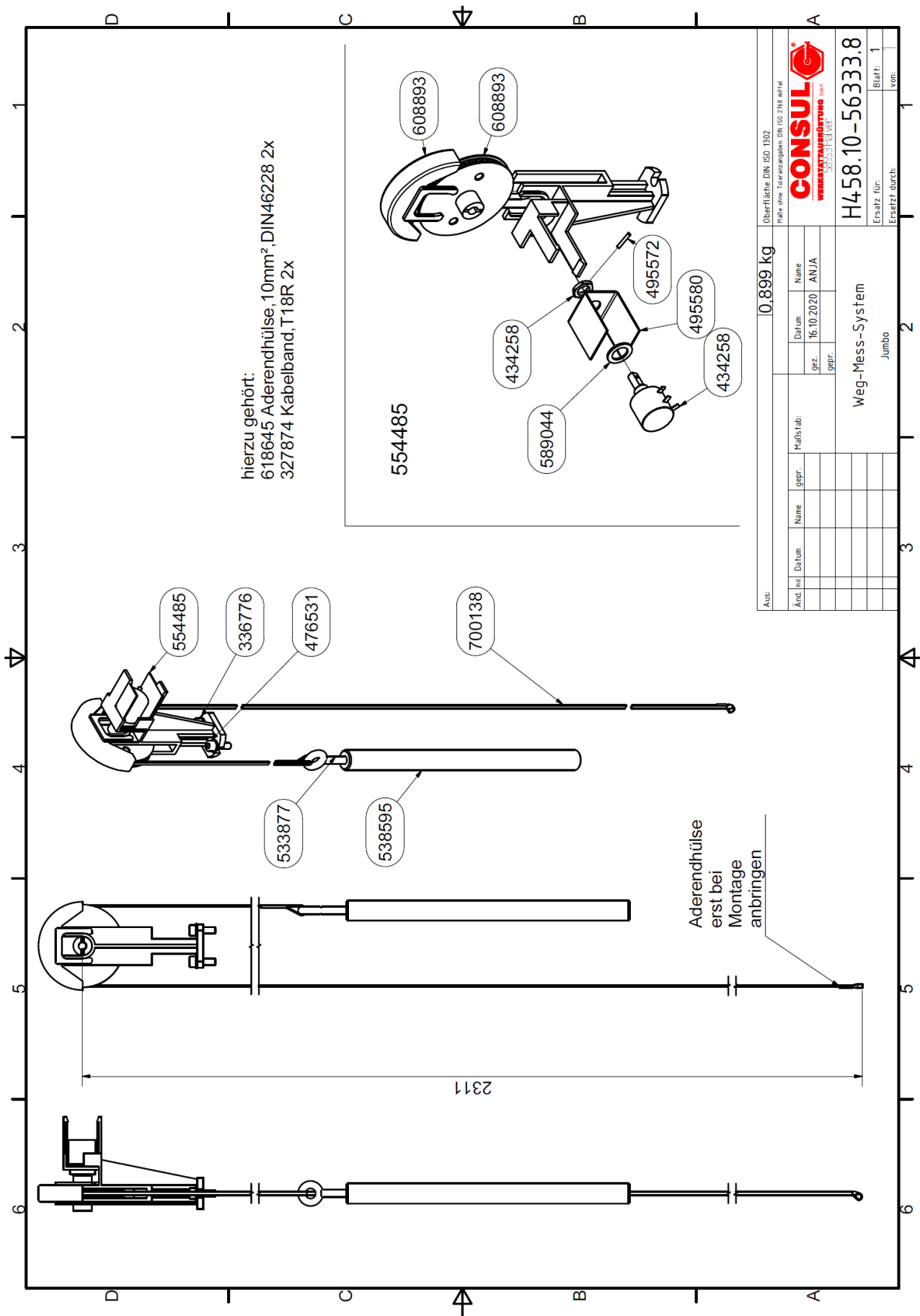

Spare Parts list 563338

Pos.	Menge	Item No.:	BESCHREIBUNG	Description
1	1	554485	Umlenkrolle + Poti montiert	Deflector roller and potentiometer mounted
2	1	700138	Zahnriemen	Timing belt
3	1	538595	Gegengewicht	Counterweight
4	1	533877	Ösenschraube M6	Eyebolt M6
5	2	476531	Zyl-Schraube	Socket head screw
6	2	336776	Scheibe DIN 125-1 A A 5,3	Washer
7	2	327874	Aderendhülse	Ferule

Subject to change without prior notice!

Stand: 10/2020

Spare parts list 554485

Pos.	Menge	Item No.:	BESCHREIBUNG	Description
1	1	608893	Potihalter kpl.	Pot holder cpl.
3	1	495572	Befestigungsstift Potii	Fixing pin
4	1	495580	Befestigungsblech	Mounting plate
6	1		Potimutter	Nut
7	1	434258	Potentiometer 10kOhm	Potentiometer
8	1		Stützscheibe DIN 988 S11 x 17	Support washer

Subject to change without prior notice!

Stand: 10/2020

Articulated arms

Pos.	Menge	Ident.Nr.	BESCHREIBUNG	MATERIAL
23	1	434688	DIN 6912 M12 x 50	Zylinderkopfschraube Stahl, weich, unlegiert
22	1	265538	DIN 6912 M12 x 80	Zylinderkopfschraube Stahl, weich
21	1	H33101-59989	Gegen-Stützträger	Stahl, weich
20	1	H474.00-53276	Schutzscheibe	St-52-3N -5355103
19	1	Z24.0.00-58129	Aufnahmeteller kpl.	St-37-2 - S235-R
18	1	H460.00-51286	Gelenkarm kpl. links	Allgemein
17	2	107524	DIN 125-1 A 13	Stahl, weich, unlegiert
16	2	.00-53617.7	Kantenschutz	Thermoplas Fischer
15	2	362640	DIN 934 - ersetzt durch DIN EN 24032/28673/28674, M12	Kunststoff
14	2	059592	DIN 9021 10.5	Stahl, weich, unlegiert
13	2	471805	DIN 7991 - ersetzt durch DIN EN ISO 10642 M12 x 35	Stahl, weich, unlegiert
12	1	H481.00-53616	Schutzscheibe	St-37-2 - S235-R
11	1	H460.00-52882	Sperrscheibe M=2,5 z=68	Stahl
10	2	062844	DIN 933 - ersetzt durch DIN EN 24077 M10 x 40	Stahl, weich, unlegiert
9	1	H460.00-53817	Arretierung kpl.	
8	6	531426	Spiralspannstift 8x18	
7	1	H460.00-52479	Gleitlager	DIN7343 DM8x18
6	2	038968	DIN 7991 M8x20	Senkschrauben mit Innensechskant
5	1	520718	DIN 471 - 9mm == 300mm 80 x 2,5	Sicherungsring
4	1	H460.00-51266	Gelenkboizen	St2685
3	1	H458.00-51264	Sperrscheibe	Gelenkboizen 512640
2	1	H460.00-51267	Gleitlager mit Bund	Sperrscheibe Sintermetall
1	1	H458.00-51260	Tragrohr kpl.	links Allgemein

STÜCKLISTE			
Art.Nr.	Datum	Name	Ident.Nr.
24114	17.09.2012	ANNA	
24114	12.09.2011	Kasimir	
Gelenkarm kpl. links			
H460.00-51255			
Ersetzt für: H460.00-51255			

Oberfläch. DIN ISO 1312
 Nach einer Verformung bis zu 200 mm

 3055710101

Spare parts list articulated arm left 512525

Pos.	Menge	Item No.:	BESCHREIBUNG	Description
1	1	512608	Tragarmrohr kpl. Links	Swivel arm left
2	1	512673	Gleitlager mit Bund	Plain bearing with collar
3	1	512640	Sperrscheibe	locking disc
4	1	512665	Gelenkbolzen	hinge pin
5	1	520718	Sicherungsring DIN 471 80 x 2,5	circlip
6	2	038968	Senkschraube DIN 7991 M8x20	Countersunk screw
7	1	524793	Gleitlager	bearing
8	6	531426	Spiralspannstift 8x18	Spiral pin
9	1	531871	Arretierung kpl.	locking pin
10	2	062844	Sechskantschraube DIN 933 -M10 x 40	Hex bolt DIN 933 M10 x 40
11	1	528828	Sperrscheibe M=2,5 z=68	Locking disc
12	1	536169	Schutzscheibe	safety disc
13	2	471805	Senkschraube DIN 7991 - M12 x 35	Countersunk screw
14	2	059592	Scheibe DIN 9021 10,5	washer
15	2	362640	Sechskantmutter DIN 934 - M12	Hexagon nut
16	2	536177	Kantenschutz	edge protection
17	2	107524	Scheibe DIN 125-1 A A 13	washer
18	1	512863	Gelenkarm kpl. links	Articulated arm left
19	1	581298	Aufnahmeteller kpl.	Lifting plate complete vertical adjustable
20	1	532168	Schutzscheibe	safety disc
21	1	599894	Gegen-Stützlager	counter-support bearing
22	1	265538	Zylinderschraube DIN 6912 M12 x 80	cylinder head screw
23	1	434688	Zylinderschraube DIN 6912 M12 x 50	cylinder head screw

Subject to change without prior notice!

Stand: 06/2019

Spare parts list articulated arm right 520783

Pos.	Qty	Item No.:	BESCHREIBUNG	Description
1	1	512673	Gleitlager mit Bund	Plain bearing with collar
2	1	512640	Sperrscheibe	Locking disc
3	1	512665	Gelenkbolzen	Hinge pin
4	1	520718	Sicherungsring DIN 471 80 x 2,5	Circlip
5	2	038968	Senkschraube DIN 7991 M8x20	Countersunk screw
6	1	524793	Gleitlager	bearing
7	1	520742	Tragarmrohr kpl. Links	Swivel arm left
9	6	531426	Spiralspannstift 8x18	Spiral pin
10	1	531871	Arretierung	locking pin
11	2	536177	Kantenschutz	edge protection
12	1	581298	Aufnahmeteller	Lifting plate complete vertical adjustable
13	2	362640	Sechskantmutter DIN 934 - M12	Hexagon nut
14	2	107524	Scheibe DIN 125-1 A A 13	washer
15	2	059592	Scheibe DIN 9021 10,5	washer
16	2	062844	Sechskantschraube DIN 933 -M10 x 40	Hex bolt DIN 933 M10 x 40
17	2	471805	Senkschraube DIN 7991 - M12 x 35	Countersunk screw
18	1	536169	Schutzscheibe	safety disc
19	1	528828	Sperrscheibe M=2,5 z=68	Locking disc
20	1	520734	Gelenkarm rechts	Articulated arm right
21	1	599894	Gegen-Stützlager	counter-support bearing
22	1	265538	Zylinderschraube DIN 6912 M12 x 80	cylinder head screw
23	1	434688	Zylinderschraube DIN 6912 M12 x 50	cylinder head screw
24	1	532168	Schutzscheibe	safety disc

Subject to change without prior notice!

Stand: 06/2019

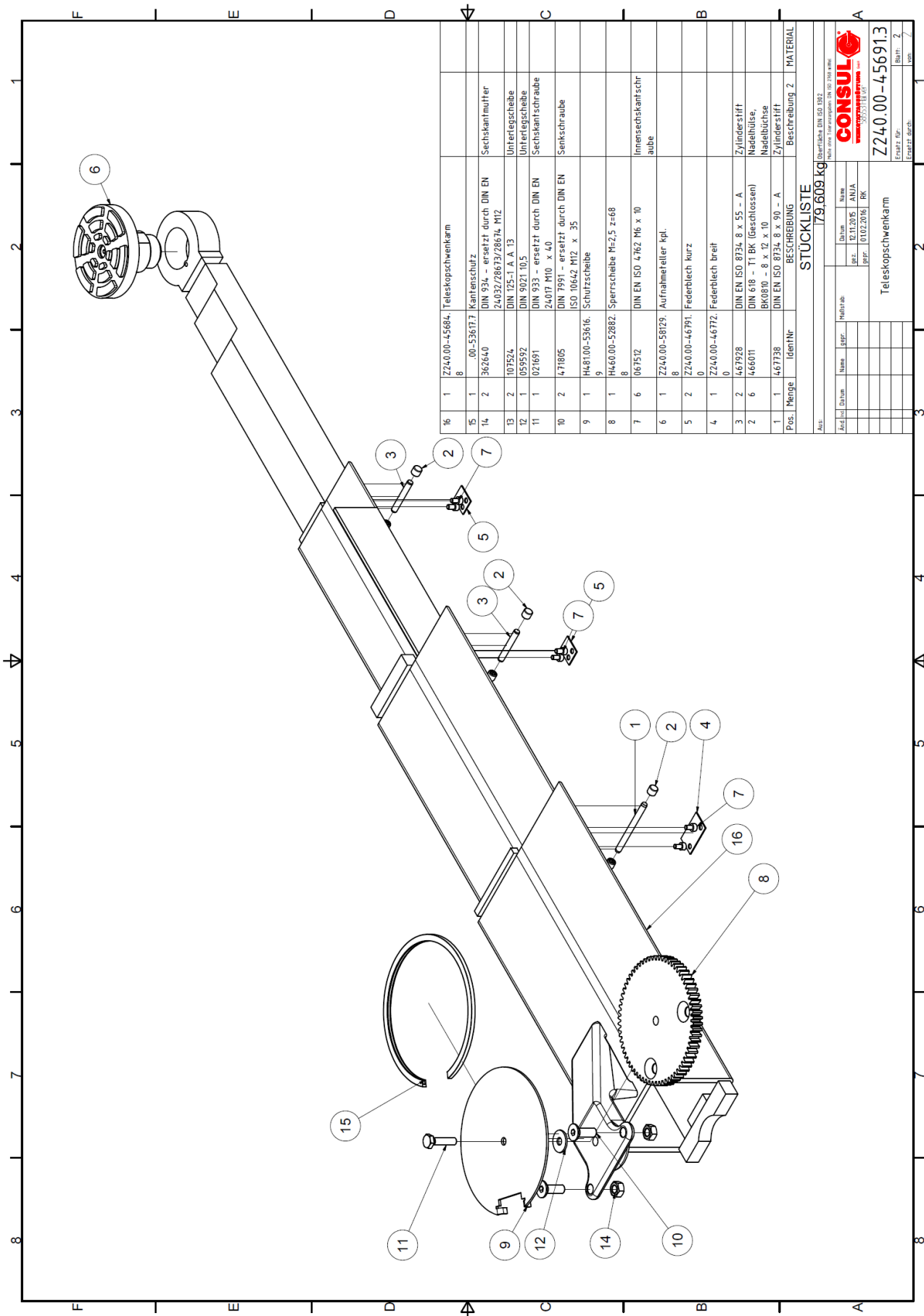

Pos.	Menge	Ident.Nr.	BESCHREIBUNG	MATERIAL
16	1	Z240.00-45684	Teleskopschwenkarm	
15	1	001-53617.7	Kantenschutz	
14	2	362640	DIN 934 - ersetzt durch DIN EN 24032/2863/28674, M12	Sechskantmutter
13	2	107524	DIN 925-1 A, A 13	Untertagscheibe
12	1	059592	DIN 9021 M0,5	Untertagscheibe
11	1	021691	DIN 933 - ersetzt durch DIN EN 24017 M10 x 40	Sechskantschraube
10	2	471805	DIN 7991 - ersetzt durch DIN EN ISO 10042 M12 x 35	Senkschraube
9	1	H48100-53616	Schutzscheibe	
8	1	H46000-52882	Sperrscheibe M=2,5 z=68	
7	6	067512	DIN EN ISO 4762 M6 x 10	Innensechskantschraube
6	1	Z240.00-58729	Aufnahmeteller-kl.	
5	2	Z240.00-46791	Federblech kurz	
4	1	Z240.00-46772	Federblech breit	
3	2	467928	DIN EN ISO 8734, 8 x 55 - A	Zylinderstift
2	6	466011	DIN 618 - T1 BK (Geschlossen) BK0810 - 8 x 12 x 10	Nadelhülse, Nadelbüchse
1	1	467738	DIN EN ISO 8734, 8 x 90 - A	Zylinderstift
Pos. Menge Ident.Nr. BESCHREIBUNG				Beschreibung 2
Menge				179,609 kg
Art.Nr.				Dienstreifen DIN ISO 1802
Art.Nr.	Datum	Name	Proj.	Zeichn.
			12.11.2015	ANJA
			0102/2016	BK
STÜCKLISTE				
Teleskopschwenkarm				Z240.00-456913
Erstellt für				Blatt 2
Erstellt durch				Von 2

Spare parts list swivel arm 5,5t- 45691.3

Pos.	Menge	Item No.:	BESCHREIBUNG	Description
1	1	467738	Zylinderstift DIN EN ISO 8734 8 x 90 - A	cylinder pin
2	4	466011	Nadelhülse DIN 618 - T1 BK - 8 x 12 x 10	Needle sleeve
3	1	467928	Zylinderstift DIN EN ISO 8734 8 x 55 - A	cylinder pin
4	1	467720	Federblech breit	Spring plate long
5	1	467910	Federblech kurz	Spring plate short
6	1	581298	Aufnahmeteller kpl.	Support plate cpl.
7	4	107441	Scheibe DIN 125-1 A A 6,4	washer
7	4	067512	Zylinderkopfschraube DIN 6912 M6 x 10	cylinder head bolt
8	1	528828	Sperrscheibe M=2,5 z=68	Locking disk
9	1	536169	Schutzscheibe	Safety washer
10	2	471805	Senkschraube DIN 7991 - M12 x 35	countersunk screw
11	1	062844	Sechskantschraube DIN 933 - M10 x 40	hexagon screw
12	1	059592	Scheibe DIN 9021 10,5	washer
13	2	107524	Scheibe DIN 125-1 A A 13	washer
14	2	362640	Sechskantmutter DIN 934 - M12	hexagon nut
15	1	536177	Kantenschutz	Edge protection
16	1	456848	Teleskopschwenkarm rechts	Swivel arm right

Subject to change without prior notice!

Stand: 06/2019

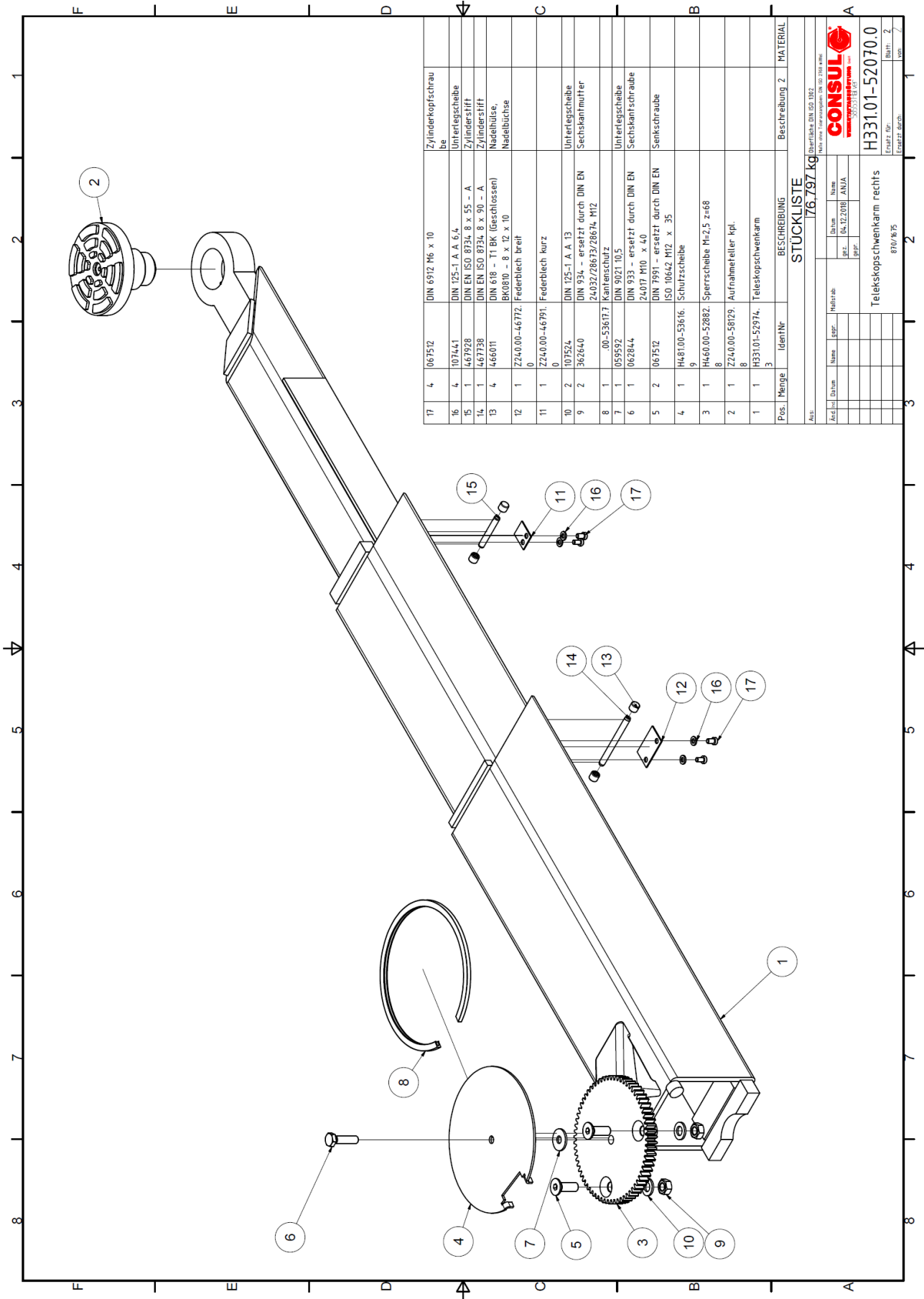

Pos.	Menge	Ident.Nr.	BESCHREIBUNG	MATERIAL
17	4	067512	DIN 6912 M6 x 10	Zylinderkopfschraube
16	4	107441	DIN 125-1 A A 6,4	Unterlegscheibe
15	1	467928	DIN EN ISO 8734 8 x 55 - A	Zylinderstift
14	1	467738	DIN EN ISO 8734 8 x 90 - A	Zylinderstift
13	4	466011	DIN 618 - T1 BK (Geschlossen)	Nadelhülse
12	1	Z240.00-46712	0	Nadelbüchse
11	1	Z240.00-46791	0	Federblech breit
10	2	107524	DIN 125-1 A A 13	Unterlegscheibe
9	2	362640	DIN 934 - ersetzt durch DIN EN 24032/28673/28674, M12	Sechskantmutter
8	1	00-53617.7	Kantenschutz	
7	1	059592	DIN 9021 10,5	Unterlegscheibe
6	1	062844	DIN 933 - ersetzt durch DIN EN 24017 M10 x 40	Sechskantschraube
5	2	067512	DIN 7991 - ersetzt durch DIN EN ISO 10642 M12 x 35	Senkschraube
4	1	H481.00-53616	Schutzscheibe	
3	1	H460.00-52882	Sperrscheibe M=2,5 z=68	
2	1	Z240.00-58129	Aufnahmeteller kpl.	
1	1	H331.01-52974	Teleskopschwankenarm	

STÜCKLISTE		
Gesamtgewicht: 176,797 kg		
Ubersicht über DIN ISO 1802		
Auftr./Datum	Name	Grp.
Herz/Hab	Da/Von	Name
	04.12.2018	ANJA
gez.	ppr.	
Teleskopschwankenarm rechts		
H331.01-52070.0		
Einzel-Druck: 8/10/8/75		
Blatt: 2		
von: 2		

Swivel arm right 520700

Pos.	Menge	Item No.:	BESCHREIBUNG	Description
1	1	529743	Teleskopschwenkarm rechts	Swivel arm right
2	1	581298	Aufnahmeteller kpl.	Support plate cpl.
3	1	528828	Sperrscheibe M=2,5 z=68	Locking disk
4	1	536169	Schutzscheibe	Safety washer
5	2	471805	Senkschraube DIN 7991 - M12 x 35	countersunk screw
6	1	062844	Sechskantschraube DIN 933 - M10 x 40	hexagon screw
7	1	059592	Scheibe DIN 9021 10,5	washer
8	1	536177	Kantenschutz	Edge protection
9	2	362640	Sechskantmutter DIN 934 - M12	hexagon nut
10	2	107524	Scheibe DIN 125-1 A A 13	washer
11	1	467910	Federblech kurz	Spring plate short
12	1	467720	Federblech breit	Spring plate long
13	4	466011	Nadelhülse DIN 618 - T1 BK - 8 x 12 x 10	Needle sleeve
14	1	467738	Zylinderstift DIN EN ISO 8734 8 x 90 - A	cylinder pin
15	1	467928	Zylinderstift DIN EN ISO 8734 8 x 55 - A	cylinder pin
16	4	107441	Scheibe DIN 125-1 A A 6,4	washer
17	4	067512	Zylinderkopfschraube DIN 6912 M6 x 10	cylinder head bolt

Subject to change without prior notice!

Stand: 06/2019

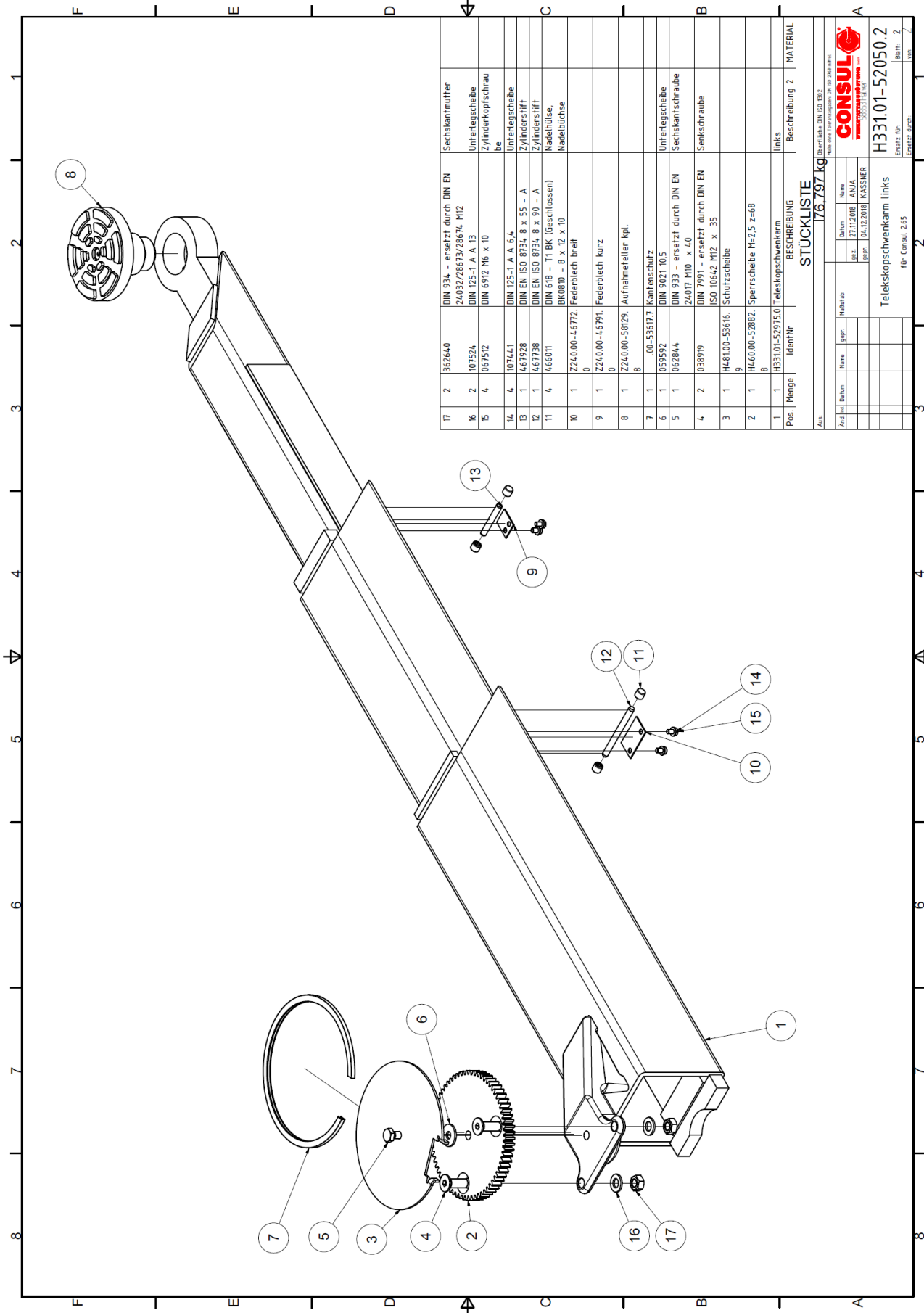

Pos.	Menge	Ident.Nr	BESCHREIBUNG	links	MATERIAL
17	2	362640	DIN 934 - ersetzt durch DIN EN 24037/28673/28674 M12		Sechskantmutter
16	2	107524	DIN 125-1 A A 13		Unterlegscheibe
15	4	106752	DIN 6912 M6 x 10		Zylinderkopfschraube
14	4	107441	DIN 125-1 A A 6,4		Unterlegscheibe
13	1	467928	DIN EN ISO 8734 8 x 55 - A		Zylinderstift
12	1	467738	DIN EN ISO 8734 8 x 90 - A		Zylinderstift
11	4	466011	DIN 618 - T1 BK (Geschlessen)		Nadelbüse, Nadelsbüchse
10	1	Z24.0.00-46772	Federblech breit		Nadelbüchse
9	1	Z24.0.00-46791	Federblech kurz		
8	1	Z24.0.00-58129	Aufnahmeteller kpl.		
7	1	00-536177	Kantenschutz		
6	1	059592	DIN 9021 10,5		Unterlegscheibe
5	1	1062844	DIN 933 - ersetzt durch DIN EN 24037 M10 x 4,0		Sechskantschraube
4	2	1038919	DIN 7991 - ersetzt durch DIN EN ISO 10662 M12 x 35		Senkschraube
3	1	H481.00-53616	Schutzscheibe		
2	1	H460.00-52882	Sperrscheibe M=2,5 z=68		
1	1	H331.01-52975.0	Teleskopschwienkarm	links	
STÜCKLISTE					
BESCHREIBUNG					
Teleskopschwienkarm links					
für Consul 265					
76.797 kg					
überfläche DIN ISO 1582					

CONSUL
 H331.01-52050.2
 Ersatz Nr. _____ Blatt _____ von _____
 Erzeugt durch _____

Swivel arm left 520502

Pos.	Menge	Item No.:	BESCHREIBUNG	Description
1	1	529750	Teleskopschwenkarm links	Swivel arm left
2	1	528828	Sperrscheibe M=2,5 z=68	Locking disk
3	1	536169	Schutzscheibe	Safety washer
4	2	471805	Senkschraube DIN 7991 - M12 x 35	countersunk screw
5	1	062844	Sechskantschraube DIN 933 - M10 x 40	hexagon screw
6	1	059592	Scheibe DIN 9021 10,5	washer
7	1	536177	Kantenschutz	Edge protection
8	1	581298	Aufnahmeteller kpl.	Support plate cpl.
9	1	467910	Federblech kurz	Spring plate short
10	1	467720	Federblech breit	Spring plate long
11	4	466011	Nadelhülse DIN 618 - T1 BK - 8 x 12 x 10	Needle sleeve
12	1	467738	Zylinderstift DIN EN ISO 8734 8 x 90 - A	cylinder pin
13	1	467928	Zylinderstift DIN EN ISO 8734 8 x 55 - A	cylinder pin
14	4	107441	Scheibe DIN 125-1 A A 6,4	washer
15	4	067512	Zylinderkopfschraube DIN 6912 M6 x 10	cylinder head bolt
16	2	107524	Scheibe DIN 125-1 A A 13	washer
17	2	362640	Sechskantmutter DIN 934 - M12	hexagon nut

Subject to change without prior notice!

Stand: 06/2019

Supply of Spare Parts

Indication of reparation services and purchase of spare parts

Customer service of the manufacturer:



Consul Werkstattausrüstung GmbH

Daimlerstr. 1

D-58553 Halver

Telefon: +49 (0) 23 53 / 7009 - 0

Telefax: +49 (0) 23 53 / 1 25 15

E-Mail: info@consul-gmbh.de

Customer service of the supplier:
(Please insert stamp or address)

Company: _____

Street: _____

City: _____

Telephone: _____

Informations for practising the sight –and function check

during the regular inspection after chapter 5.4,3 part 2 after BG-principle during the regular inspection are special to proof:

1. details of the post lifts	test object
name plate inscription installation and operation instructions	attachment readability completeness
2. extensive operating instructions	status readability
3. warning designation	status visibility
4. contrivance against unauthorized usage	status function well running safety key
5. emergency switching-off emergency let down	status function well running
6. signal facilities, facilities for communication	status function visibility reliable
7. facilities, for stability assembly	
supports	status function wear deformation corrosion cleft
8. supporting structure	clefts deformation corrosion well running between leads, rolls, articulation, telescope, wear between leads, rolls, articulation, bearing attachment and safety of removable connections functionality of the closing
9. load capture medium	
slip off securing roll off securing holding facilities articulation arm securing	status function
10. steel wire cable steel wire cable connections	wear corrosion wire breaking wire breaking nests squeeze parts loosening of the outside layer multi-strand rope bird caged
pulley	cleft wear wire edge at the pulley right sight out of the pulleys

cable winding fastening device contrivance of the cable winding on place contrivance against come down of the cable	status function
11. spindle	arrangement deformation dirt accumulation thread wear nick scoring striation, apply functionality of the covering
carrying nut	thread wear (backlash of threads)
compensation ring	bedding status nick scoring
12. hydraulics	leak place leak test aerating
oil supplies	status and readability of the advertisement, control of the oil-level functionality of the cut-off facility if oil need
conduits connections	arrangement damage deformation corrosion
tube tube connections	arrangement damage age brittleness fragility
cylinder	arrangement cleft pipe - and flexible tube connection closeness of the collar
piston	surface of the piston rod scoring dirt accumulation
filter	outside status
pressure relief valve	outside status leaden seal undamaged
13. pneumatic	
conduits connections	leakage arrangement damage deformation corrosion
tube tube connections	arrangement damage age brittleness fragility
cylinder	arrangement, cleft, pipe - and tube connections closeness of the collar
piston	surface of the piston rod, scoring dirt accumulation
emergency valve	outside status leaden seal undamaged
manometer, pressure reducer	outside status agency
14. driving gear (no- traversing)	connections between driving gear starting without jerk

brakes, self-locking gear, coupling	wear functionality
15. undercarriage, no- traversing	
operation brakes block up brakes	wear functionality
pole contrivance	status functionality
16. electrical installation	
wire	damage, arrangement, mains lead cleat outside wire
protective conductor	damage, arrangement
isolation /lifting arrangement even lifting arrangement / running gear	dirt, damage, direct-current resistivity
17. special safety arrangements	
emergency stop, slack rope switch, slack chain switch, rope breakage switch chain breakage switch , steering blockade turn-off block, starting safety safety catch, completeness	functionality, arrangement, status deformation, well running of the control element dirt accumulation, status of the compression spring

These references take not claim for completeness and have to coordinate with the testing
lifting arrangement]

DGUV G308-003

test book for post lifts

(up to BGG945)

association of industrial employer's liability insurance association

technical board " conveyor and load suspension means" of BGZ Juli 2001