

KOP2555(-S)-XHB-EUK



Smart City Kiosks

INCLUDES 55" XTREME™ HIGH BRIGHT OUTDOOR DISPLAY

Replace static signage with Peerless-AV's award-winning Smart City Kiosk for greater public engagement and seamless updates of digital content whenever, wherever. With a focus on functionality and aesthetics, the Smart City Kiosk is designed to be modern, approachable, practical, and endure the rigours of everyday use. Installation is easy without the need for cranes or forklifts, and the locking rear door offers quick access to the display for maintenance. The included 55" Xtreme™ High Bright Outdoor Display offers full HD1080p resolution for a bright, crisp picture, even in direct sunlight. Peerless-AV's all-weather rated Smart City Kiosk is ideal for sharing community information, travel, and weather details, as well as wayfinding, advertising, entertainment, and more.

All Weather Rated Display: IP66



Display's Operating Temperature Range:
-35°C to 60°C
(-31°F - 140°F)

- Includes Peerless-AV® 55" (XHB553) Xtreme™ High Bright Outdoor Display to offer maximum flexibility
- Elegant, minimalistic design covers, protects and ventilates display and equipment
- No additional layer of glass needed between display and enclosure, reducing glare
- Wind tested up to 140 mph



AMBIENT LIGHT SENSOR

Automatically adjusts the display's brightness to best match lighting conditions

IP66 RATED DISPLAY

Fully sealed design prevents the ingress of foreign materials, such as water, dust, moisture and insects, from entering the display

ULTRA SLIM DESIGN

Sleek and stylish, yet rugged enough to be installed in any application

MEDIA STORAGE AREA

Protects electronic components with filters and cooling fans

Kiosk: **RoHS**
2002/95/EC

info@peerless-av.com
peerless-av.com

peerless-AV
Driving Technology Through Innovation

Model Numbers

Smart City Kiosk Enclosure Warranty: 5 Years
Xtreme™ High Bright Outdoor Display Warranty: 2 Years

KOP2555(-S)-XHB-EUK Smart City Kiosk, Includes 55" Xtreme™ High Bright Outdoor Display

Product Specifications

	DIMENSIONS (W x H x D)	STORAGE SPACE (W x H x D)	PRODUCT WEIGHT	FINISH	AVAILABLE COLORS
KOP2555(-S)-XHB-EUK	899 x 2091 x 216mm (35.38" x 82.34" x 8.50")	Top: 736 x 101 x 139mm (29.00" x 4.00" x 5.50") Bottom: 736 x 228 x 133mm (29.00" x 9.00" x 5.25")	162kg (357lb)	Smooth Powder Coat	Black or Silver

Package Specifications

	PACKAGE SIZE (W x H x D)	PACKAGE SHIP WEIGHT	PACKAGE UPC CODE	PACKAGE CONTENTS	UNITS IN PACKAGE
KOP2555(-S)-XHB-EUK	965 x 2413 x 686mm (38.00" x 95.00" x 27.00")	169kg (372lb)	KOP2555-XHB-EUK: 735029324577 KOP2555-S-XHB-EUK: 735029324584	Kiosk, Mounting Hardware, Xtreme™ High Bright Outdoor Display and Instructions	1

All dimensions = inch (mm)

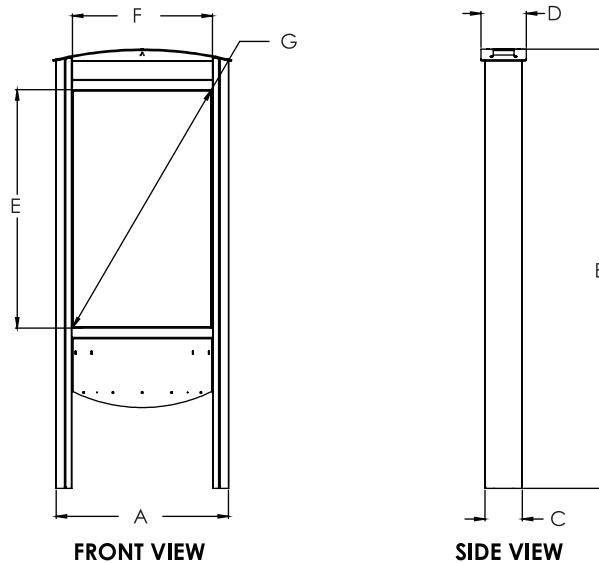

MODEL NO.	DIMENSION "A"	DIMENSION "B"	DIMENSION "C"	DIMENSION "D"	DIMENSION "E"	DIMENSION "F"	DIMENSION "G"
KOP2555-XHB-EUK	35.38" (899mm)	82.34" (2091mm)	7.00" (178mm)	8.50" (216mm)	50.11" (1273mm)	29.06" (738mm)	55.00" (1397mm)

Architect Specifications

The Smart City Kiosk shall be a Peerless-AV® model KOP2555(-S)-XHB-EUK and shall be located where indicated on the plans. Assembly and installation shall be done according to instructions provided by the manufacturer.

Visit peerless-av.com to see the complete line of AV solutions from Peerless-AV, including outdoor displays, kiosks, display mounts, projector mounts, carts/stands, and a full assortment of accessories.

Peerless-AV
 2300 White Oak Circle
 Aurora, IL 60502 USA
(800) 865-2112
(630) 375-5100
Fax: (800) 359-6500

Peerless-AV EMEA
 Unit 3 Watford Interchange
 Colonial Way, Watford
 Herts, WD24 4WP
 United Kingdom
+44 (0) 1923 200100
Fax: +44 (0) 1923 200101

Peerless-AV Latin America
 Ave de las Industrias 413
 Parque Industrial Escobedo
 Escobedo, N.L.,
 Mexico 66062
+52 (81) 8384-8300
Fax: +52 (81) 8384-8360

peerless-AV®
 Driving Technology Through Innovation