

DS-LEDZRD-4X4, 5X5, 8X8



C-series



B-series

CLED-B12A/B15A
CLED-C12A/C15A

SEAMLESS **KITTED** Flat dvLED Mounting System

FOR SONY CRYSTAL B AND C SERIES DIRECT VIEW LED DISPLAYS

Peerless-AV's SEAMLESS Kitted Series Flat dvLED Mounting System is designed exclusively for the Sony Crystal B and C Series Direct View LED Displays, offering slim, space-saving, and aesthetically appealing designs for multiple configurations. With integrated cable management, easy-hang hardware, and a lightweight aluminium frame, integrators can quickly and easily build the perfect video wall. Peerless-AV® also offers start to finish support through the SEAMLESS dvLED Video Wall Integration Program. The Peerless-AV dvLED Solutions Team is there every step of the way to ensure every customer receives SEAMLESS product support and service.

SONY

DS-LEDZRD-8X8 shown

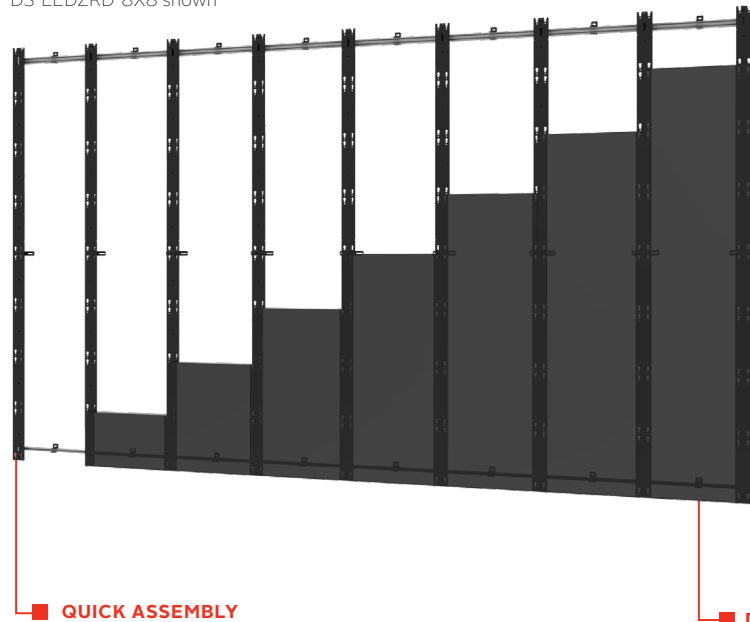

HEIGHT ADJUSTMENT
Overcome installation irregularities to assure the dvLED pixels are aligned

QUICK ASSEMBLY
Predetermined adaptor rail locations speed up assembly

DEPTH ADJUSTMENT
The entire mount creates one flat plane, regardless of wall imperfections

- Lightweight aluminium frame is easy to install and minimises the wall load
- Modular design offers unlimited video wall display configurations
- Tight tolerances and wall plate spacers ensure the cabinets are properly positioned

SEAMLESS by Peerless-AV® - dvLED Video Wall Integration Program offers:

 EXPERT TEAM	 MARKETING SUPPORT	 CUSTOM CAPABILITY	 DEDICATED LED MOUNTING SOLUTIONS
 PRECISION ENGINEERING	 LIGHTWEIGHT DESIGN	 INSTALLER FRIENDLY	 CERTIFIED TRAINING

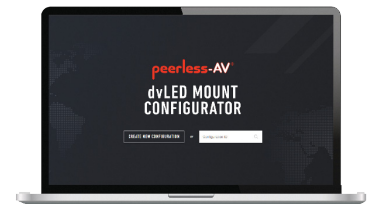

Visit Peerless-AV.com/SEAMLESS to get your project started!

DS-LEDZRD-4X4	SEAMLESS Kitted Series Flat dvLED Mounting System for 4x4 Sony Crystal B and C Series Direct View LED Displays
DS-LEDZRD-5X5	SEAMLESS Kitted Series Flat dvLED Mounting System for 5x5 Sony Crystal B and C Series Direct View LED Displays
DS-LEDZRD-8X8	SEAMLESS Kitted Series Flat dvLED Mounting System for 8x8 Sony Crystal B and C Series Direct View LED Displays

Product Specifications

	DIMENSIONS (W x H x D)	PRODUCT WEIGHT	LOAD CAPACITY	FINISH	AVAILABLE COLOURS
DS-LEDZRD-4X4	95.75" x 53.82" x 2.12"-2.87" (2,432 x 1,367 x 54-73mm)	57lb (26kg)	352lb (160kg)	Powder Coat & Clear Anodized Finish	Black & Silver
DS-LEDZRD-5X5	119.69" x 67.28" x 2.12"-2.87" (3,040 x 1,709 x 54-73mm)	73lb (33kg)	550lb (250kg)		
DS-LEDZRD-8X8	191.50" x 107.56" x 2.12"-2.87" (4,864 x 2,732 x 54-73mm)	138lb (63kg)	1,408lb (640kg)		

Package Specifications

	PACKAGE SIZE (W x H x D)	PACKAGE SHIP WEIGHT	PACKAGE UPC CODE	PACKAGE CONTENTS	UNITS IN PACKAGE
DS-LEDZRD-4X4	66.50" x 29.00" x 8.00" (1,689 x 737 x 203mm)	122lb (54kg)	735029345145	Wall Plate, Mounting Bracket, Spacer & Hardware	1
DS-LEDZRD-5X5	116.50" x 29.00" x 8.00" (2,959 x 737 x 203mm)	191lb (87kg)	735029345152		
DS-LEDZRD-8X8	116.50" x 29.00" x 8.00" (2,959 x 737 x 203mm)	252lb (115kg)	735029345169		

Accessories

DS-LEDTK Models: Universal Trim Kit for dvLED Video Walls 3.5" to 5.9" Deep

MODEL NO.	DIMENSION "A"	DIMENSION "B"
DS-LEDZRD-4x4	53.82" (1367mm)	95.75" (2432mm)
DS-LEDZRD-5x5	67.28" (1709mm)	119.69" (3040mm)
DS-LEDZRD-8x8	107.56" (2732mm)	191.50" (4864mm)

All dimensions = inch (mm)

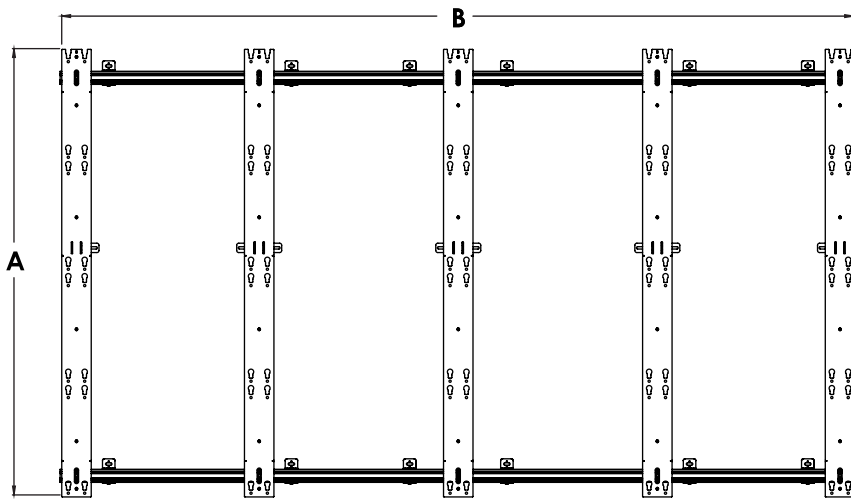

FRONT VIEW

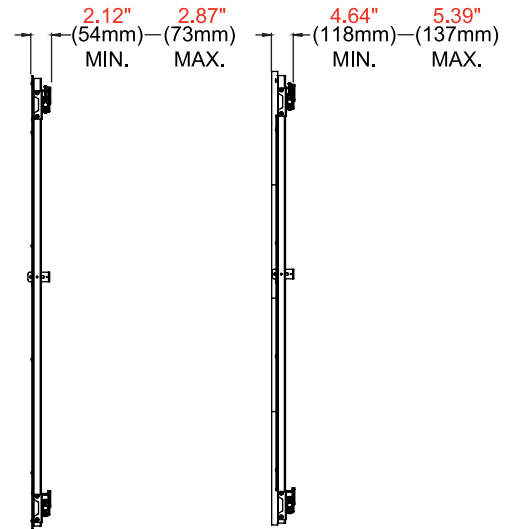

SIDE VIEW

SIDE VIEW WITH DISPLAY

Architect Specifications

The SEAMLESS Kitted Series Flat dvLED Mounting System shall be a Peerless-AV model DS-LEDZRD-4X4, 5X5, 8X8 and shall be located where indicated on the plans. Assembly and installation shall be done according to instructions provided by the manufacturer.

Visit peerless-av.com to see the complete line of AV solutions from Peerless-AV, including outdoor displays, kiosks, display mounts, projector mounts, carts/stands, and a full assortment of accessories.

Peerless-AV
2300 White Oak Circle
Aurora, IL 60502 USA

(800) 865-2112
(630) 375-5100
Fax: (800) 359-6500

Peerless-AV EMEA
Unit 3 Watford Interchange
Colonial Way, Watford
Herts, WD24 4WP
United Kingdom
+44 (0) 1923 200100
Fax: +44 (0) 1923 200101

Peerless-AV Latin America
Av. de las Industrias 413
Parque Industrial Escobedo
General Escobedo, N.L.,
México, 66062
+52 (81) 8384-8300
Fax: +52 (81) 8384-8360

