

BOS1901 Piezo Haptic Driver with Digital Front End

1 Features

- High-Voltage Low Power Piezo Driver
 - Drives 100 nF at 190 V_{pk-pk} and 300 Hz with only 350 mW
 - Drives Capacitive Load up to 820 nF
 - Energy Recovery
 - Differential Output
 - Small Solution Footprint, QFN4x4mm
 - Low BOM cost
- Integrated Digital Front End with SPI
 - 64 samples Internal FIFO Interface
 - 1.8 V to 5.0 V Digital I/O Supply
- Piezo Sensing
- Fast Start Up Time, < 300 μs
- Unidirectional Power Input option
- Wide Supply Voltage Range, 3 V to 5.5 V

2 Applications

- Mobile Phones and Tablets
- Portable Computers
- Keyboards and Mice
- Gaming Controllers
- Wearables
- Electronic Cooling

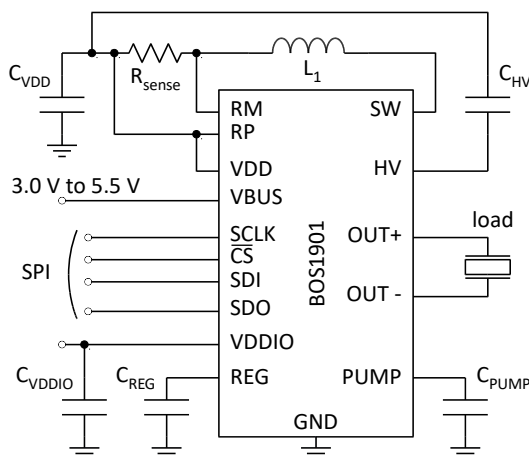

Figure 1: Simplified schematic

3 Description

The BOS1901 is a single-chip piezo actuator driver with energy recovery, based on a patent pending CapDrive™ technology. It can drive actuators with up to 190 V_{pk-pk} waveforms while operating from a 3 V to 5.5 V supply voltage. The input digital stream is written in the internal FIFO over the digital interface to generate the desired output waveform. Low power and small size make it ideal for a variety of applications requiring minimal power consumption and heat dissipation.

The BOS1901 uses a high-speed SPI in its digital front end. It enables the device to share a common communication bus for multi-actuator systems, and allows the user to query various data such as the actuator voltage for sensing applications (e.g. piezo buttons).

The differential driver achieves low distortion waveforms and quiet actuator operation. All settings are adjustable through the digital front end to reduce the BOM. Only 7 passive discrete components are required. The BOS1901 can be operated with a wide selection of COTS inductors.

In systems that cannot handle reverse current flow in the power delivery network, the BOS1901 features a unidirectional power input (UPI). When the UPI mode is activated, the driver behaves as a resistive load without reducing power efficiency.

Typical start-up time of less than 300 μs makes the BOS1901 latency negligible in most systems. Safety systems protect the device from damage in case of a fault.

Table 1: Ordering information

PRODUCT	DESCRIPTION
BOS1901Q	QFN 20L 4x4x0.8 0.5P

Information relating to products and circuits furnished herein by Boréas Technologies Inc. is believed to be reliable. However, Boréas Technologies assumes no liability for errors that may appear in this document, or for liability otherwise arising from the application or use of any such information which may result from such application or use. The products, their specifications and the information appearing in the document are subject to change by Boréas Technologies without notice. Trademarks and registered trademarks are the property of their respective owners.

Boréas Technologies Datasheet Status:

Advance Information Datasheet:	Design Data
Preliminary Information Datasheet:	Prototype information
Datasheet without notification:	Production information

© 2018 Boréas Technologies Inc.