



SWAY CONTROL SYSTEM - INSTALLATION GUIDE

Please use this QR code to be linked directly to our Sway Control System Installation video!



BULLETPROOF SWAY CONTROL WARNINGS - IMPORTANT

1. The BulletProof Sway Control system CANNOT be used on trailers with surge brakes.
2. Do NOT use the BulletProof Sway control system on class 1 hitches.
3. Proper trailer loading is your first line of defense against dangerous instability and sway. Heavy items should be placed on the floor in front of the axles. The load should be balanced side-to-side and secured to prevent shifting. Tongue weight should be about 10-15% of the gross trailer weight. Tongue weight below 10% will certainly cause trailer sway.
4. When towing during hazardous conditions such as wet, icy, snow covered roads or dirt roads turn the handle counterclockwise until all tension is removed from the system.
5. When towing a new trailer/load for the first time slowly accelerate to your cruise speed so you have time to react if the trailer starts to sway.
6. Do not speed up if sway occurs and do not apply the brakes quickly! Slowly decelerate the vehicle until the sway has stopped.
7. Never paint or lubricate the slide bar.

ADJUSTMENT

Trailer length, width, load, road conditions, towing speed, tire condition, tire pressure, and the trailers center of gravity all affect vehicle handling while towing. To get maximum results from your sway control system, a series of road tests should be taken with a loaded trailer. On subsequent trips increase or decrease tension by turning the adjustment bar in ¼ turn increments in the direction shown on the label until the desired control is achieved. For large trailers over 30 feet it may be necessary to install a second sway control system.

MAINTENANCE

After about 1000 miles of towing remove the slide bar from the sway control system and clean the friction surface with a wire brush. Repeat this cleaning procedure about every 10,000 miles.

TOOLS NEEDED

- Blue Painters Tape
- Tape Measure
- Power Drill
- 11/32" or 9mm Drill Bit
- Black Marker
- Ratchet with 9/16" Socket
- Impact Gun (optional)

NOTE: For driver side installations remove the slide bar and pressure plate and reinstall upside down.

INSTALLATION INSTRUCTIONS

- Step 1:** Connect the trailer to your BulletProof Sway Control Hitch. Position vehicle and trailer in a straight line on a level surface.
- Step 2:** Measure from the center of the coupler 24" back to your trailer tongue on the passenger side of the vehicle. Place 3-4 pieces of tape in this area so you have a place to mark.
- Step 3:** Mark a center line on the tape 24" back from the center of the coupler.
- Step 4:** Place the center of the trailer bracket on the center of the marked line and the middle of the trailer tongue. Mark the 6 holes with the black marker.
- Step 5:** Pre-drill the 6 marked holes with an 11/32 drill bit.
- Step 6:** Use the ratchet or impact gun to screw the bracket to the trailer tongue using the hex head self-tapping screws. ** DO NOT OVER TIGHTEN this will strip the screw hole.
- Step 7:** Mount the 1-1/4" sway control ball onto the hitch using the nut and lock washer and torque to 100 ft-lbs.
- Step 8:** Lightly grease both 1-1/4" balls.
- Step 9:** Attach the BulletProof Sway Control System to each ball and secure with the supplied R-clip.
- Step 10:** Tighten the bar with one finger until you can't move it and then give it an additional quarter turn. Road test the system and tighten in quarter turn increments until the sway is eliminated.

DIAGRAM A

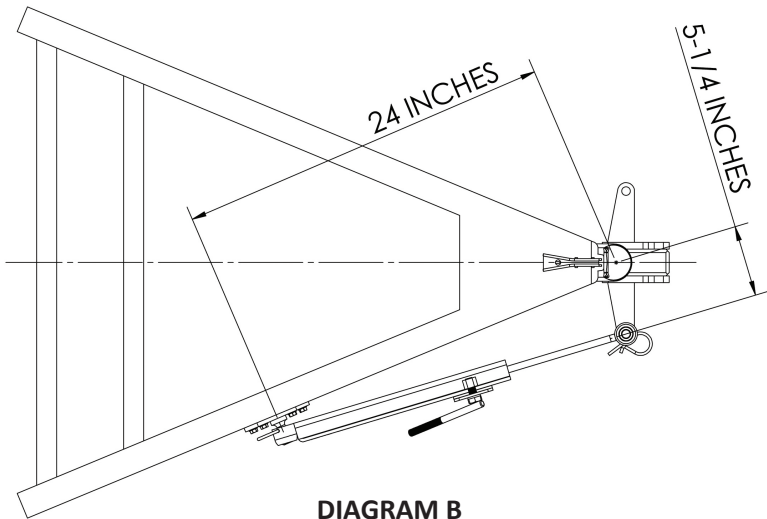

DIAGRAM B

