

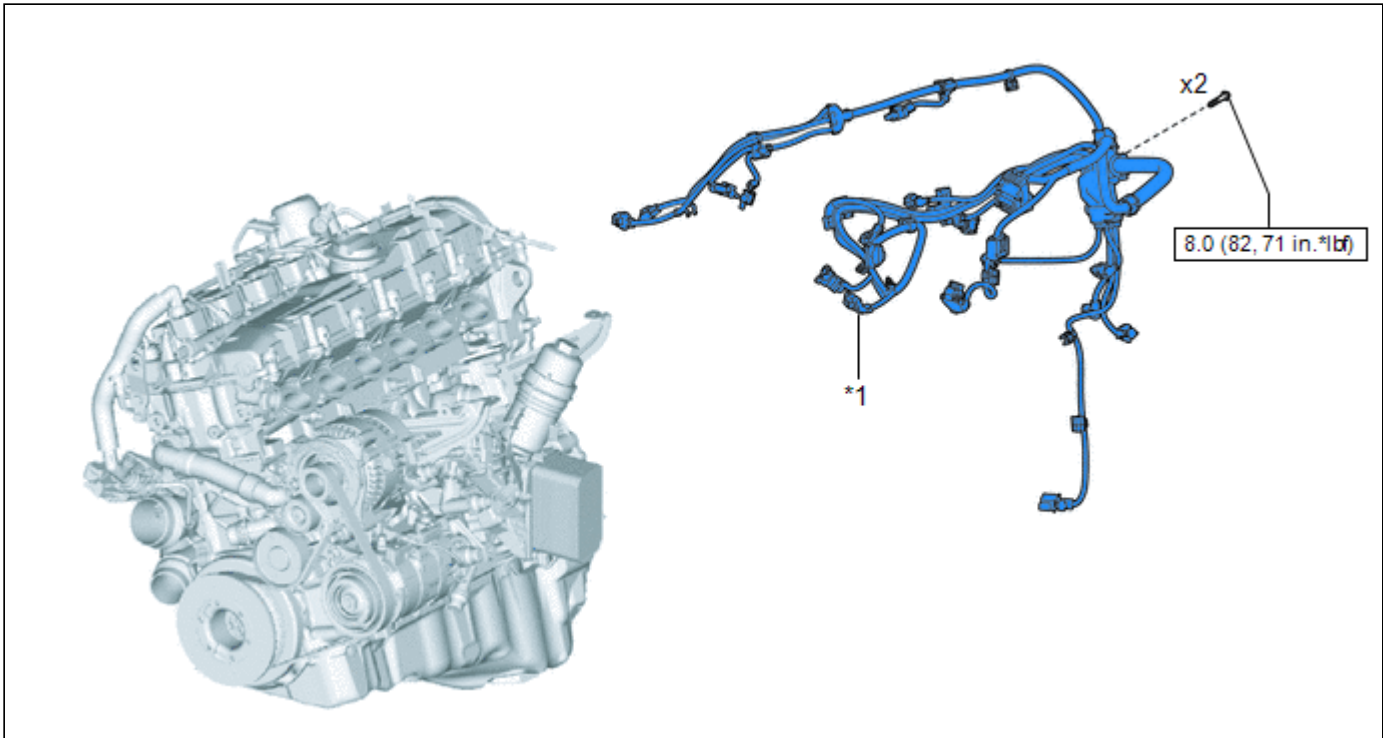

Last Modified: 10-16-2019	6.9:8.0.49	Doc ID: RM100000001JDFR
Model Year Start: 2020	Model: Supra	Prod Date Range: [03/2019 -]
Title: B58 (ENGINE MECHANICAL): CRANKSHAFT: COMPONENTS; 2020 MY Supra [03/2019 -]		

COMPONENTS

ILLUSTRATION



*1	ENGINE WIRE	-	-
	N*m (kgf*cm, ft.*lbf): Specified torque	-	-

ILLUSTRATION

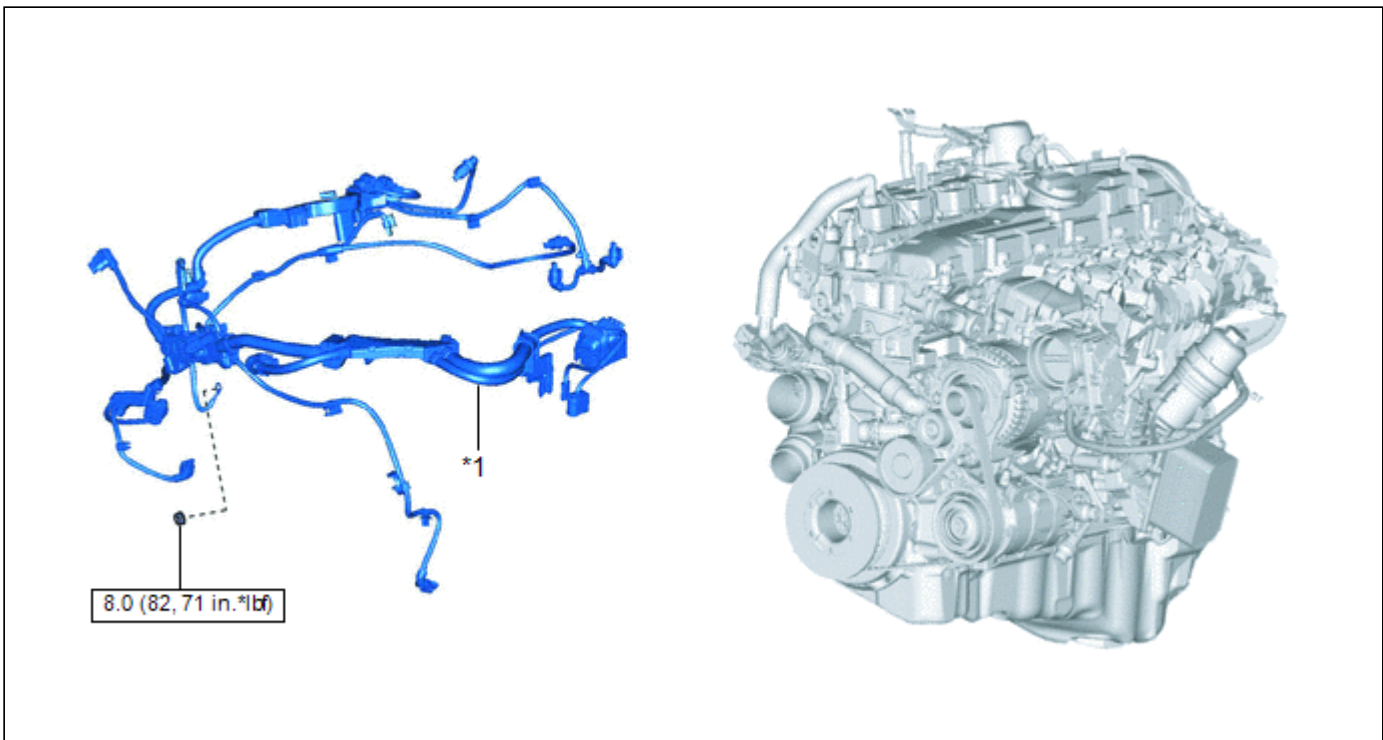

*1	NO. 2 ENGINE WIRE	-	-
	N*m (kgf*cm, ft.*lbf): Specified torque	-	-

ILLUSTRATION

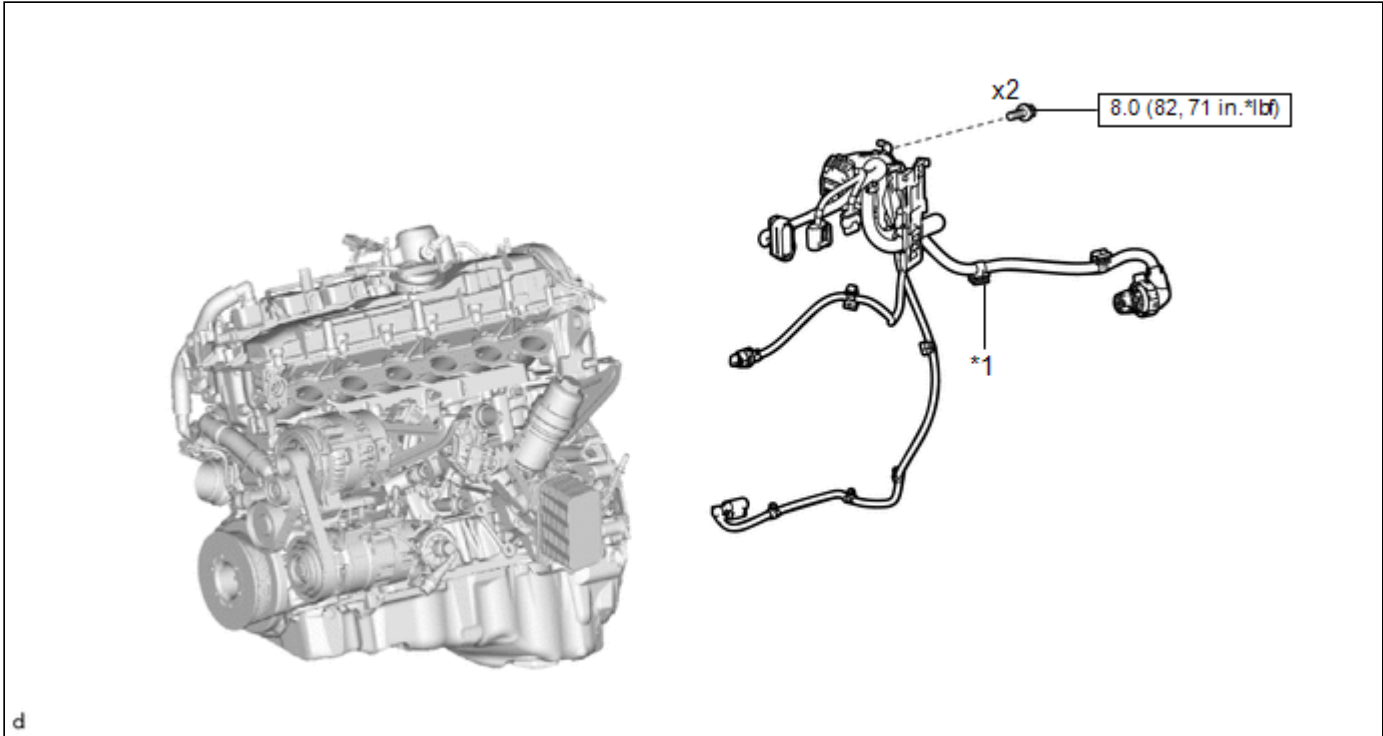



d

*1	TRANSMISSION WIRE	-	-
	N*m (kgf*cm, ft.*lbf): Specified torque	-	-

--	--	--	--

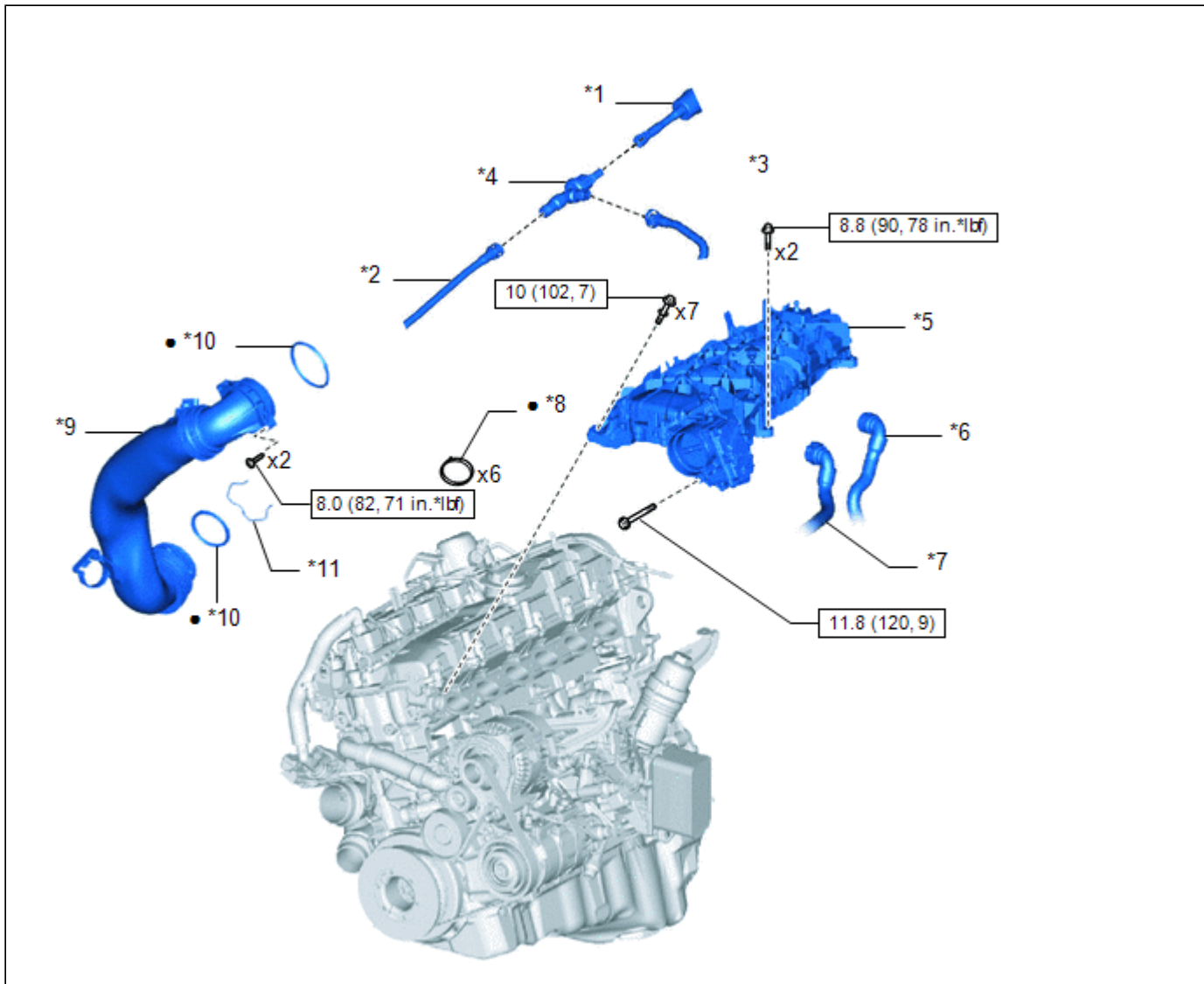
ILLUSTRATION



*1	NO. 2 FUEL VAPOR FEED HOSE	*2	NO. 1 FUEL VAPOR FEED HOSE
*3	NO. 3 FUEL VAPOR FEED HOSE	*4	NO. 1 CHECK VALVE
*5	INTAKE MANIFOLD	*6	NO. 5 WATER BY-PASS HOSE
*7	NO. 7 WATER BY-PASS HOSE	*8	NO. 1 INTAKE MANIFOLD TO HEAD GASKET
*9	NO. 2 AIR CLEANER HOSE	*10	SEALING RING
*11	AIR HOSE CLAMP	-	-
	N*m (kgf*cm, ft.*lbf): Specified torque		Non-reusable part

ILLUSTRATION

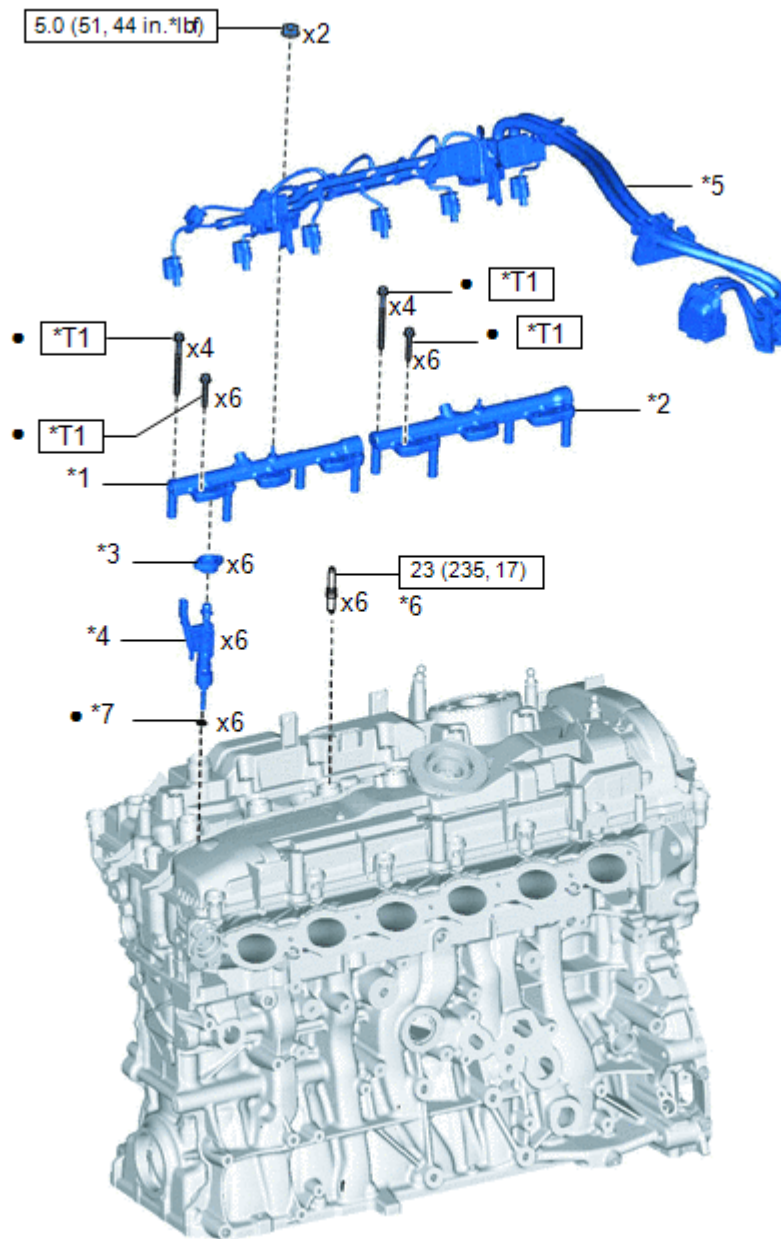

*1	FUEL DELIVERY PIPE	*2	NO. 2 FUEL DELIVERY PIPE
*3	HOLDER	*4	FUEL INJECTOR ASSEMBLY
*5	NO. 4 ENGINE WIRE	*6	SPARK PLUG
*7	O-RING	-	-
	N*m (kgf*cm, ft.*lbf): Specified torque	•	Non-reusable part
*T1	1st: 5.0 (51, 44 in.*lbf) 2nd: Turn 90°	-	-

ILLUSTRATION

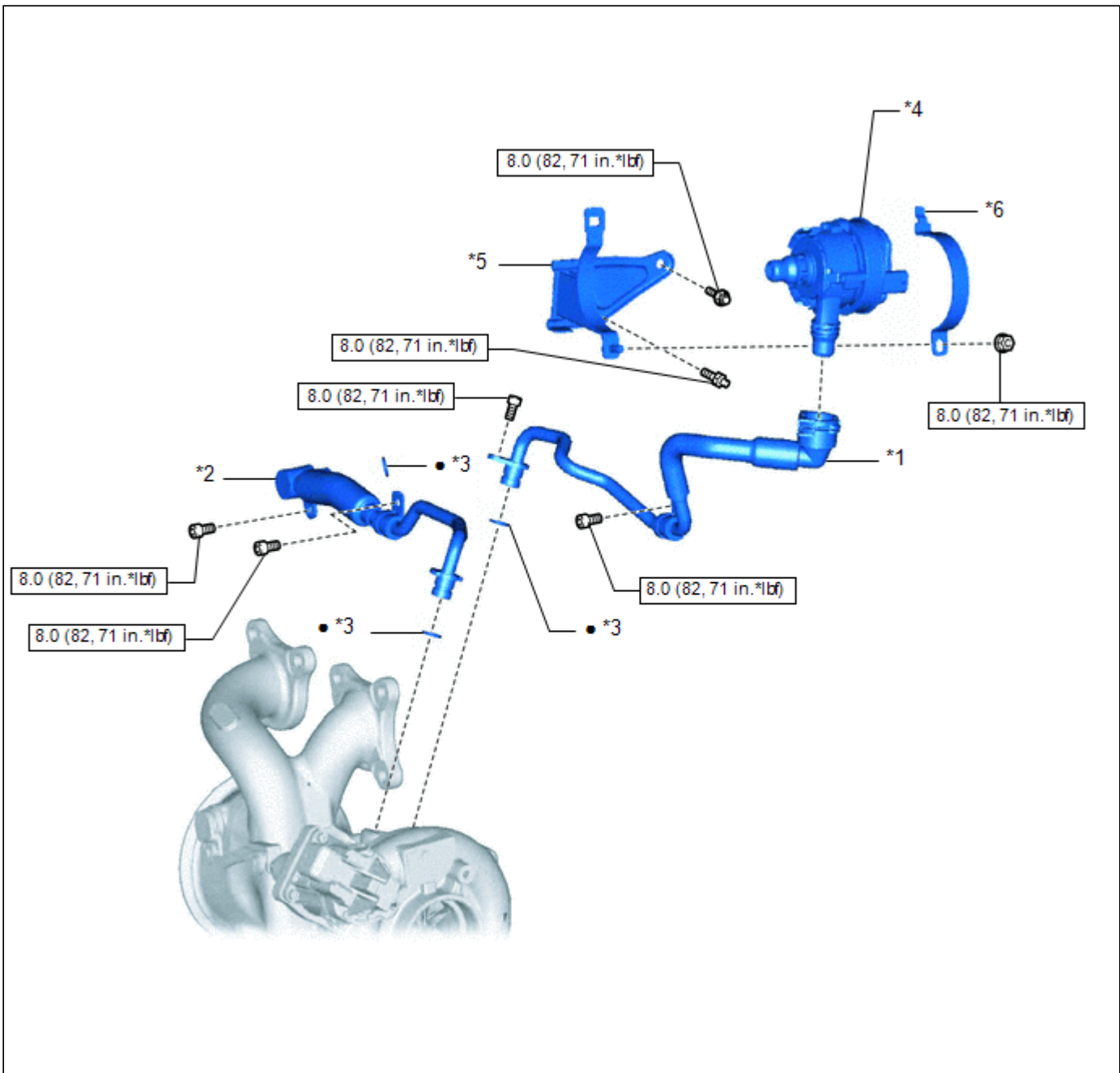

*1	NO. 1 TURBO WATER PIPE SUB-ASSEMBLY	*2	NO. 2 TURBO WATER PIPE SUB-ASSEMBLY
*3	O-RING	*4	WATER PUMP ASSEMBLY
*5	NO. 1 WATER PUMP BRACKET SUB-ASSEMBLY	*6	NO. 2 WATER PUMP BRACKET SUB-ASSEMBLY
	N*m (kgf*cm, ft.*lbf): Specified torque	•	Non-reusable part

ILLUSTRATION

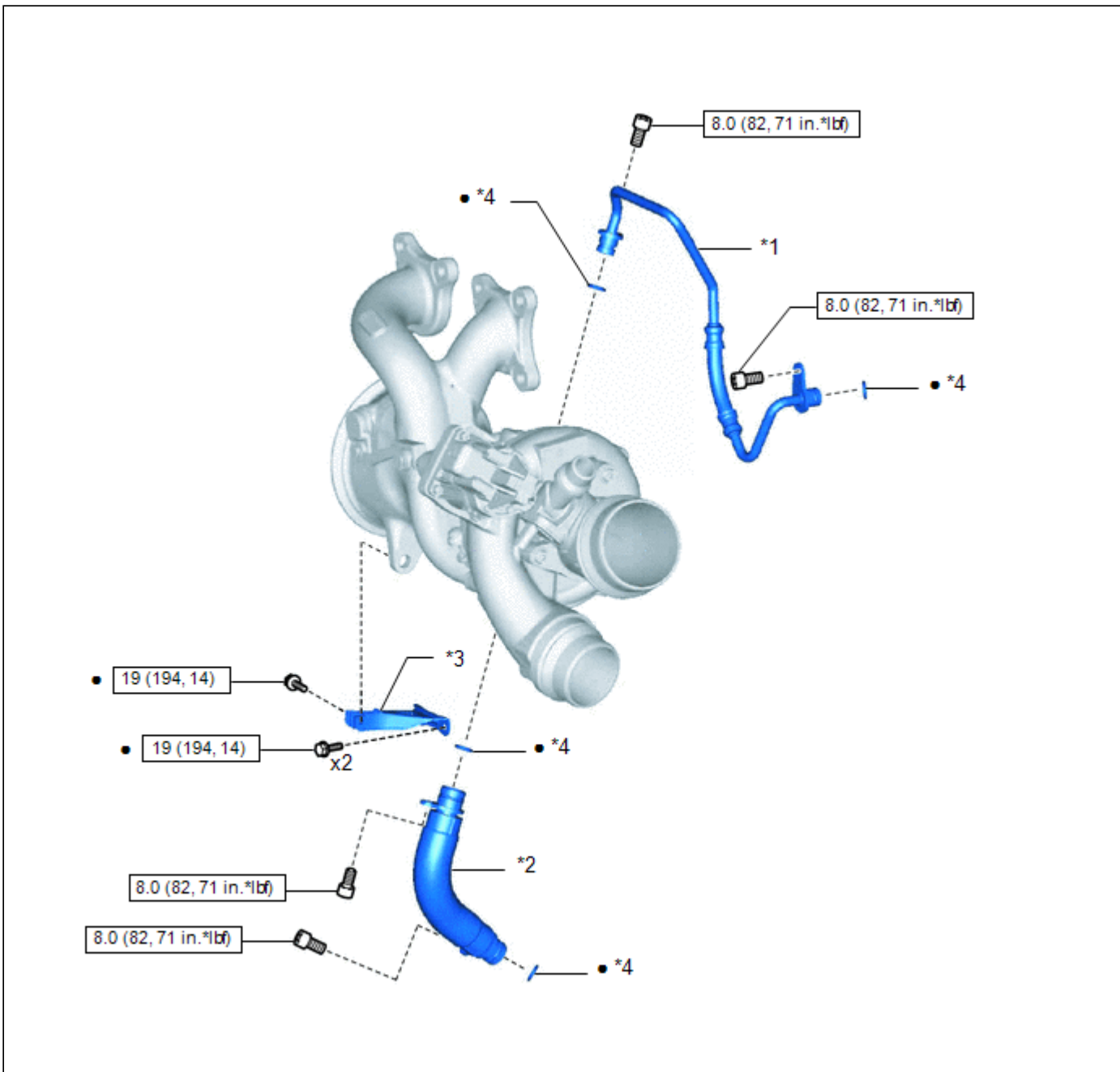

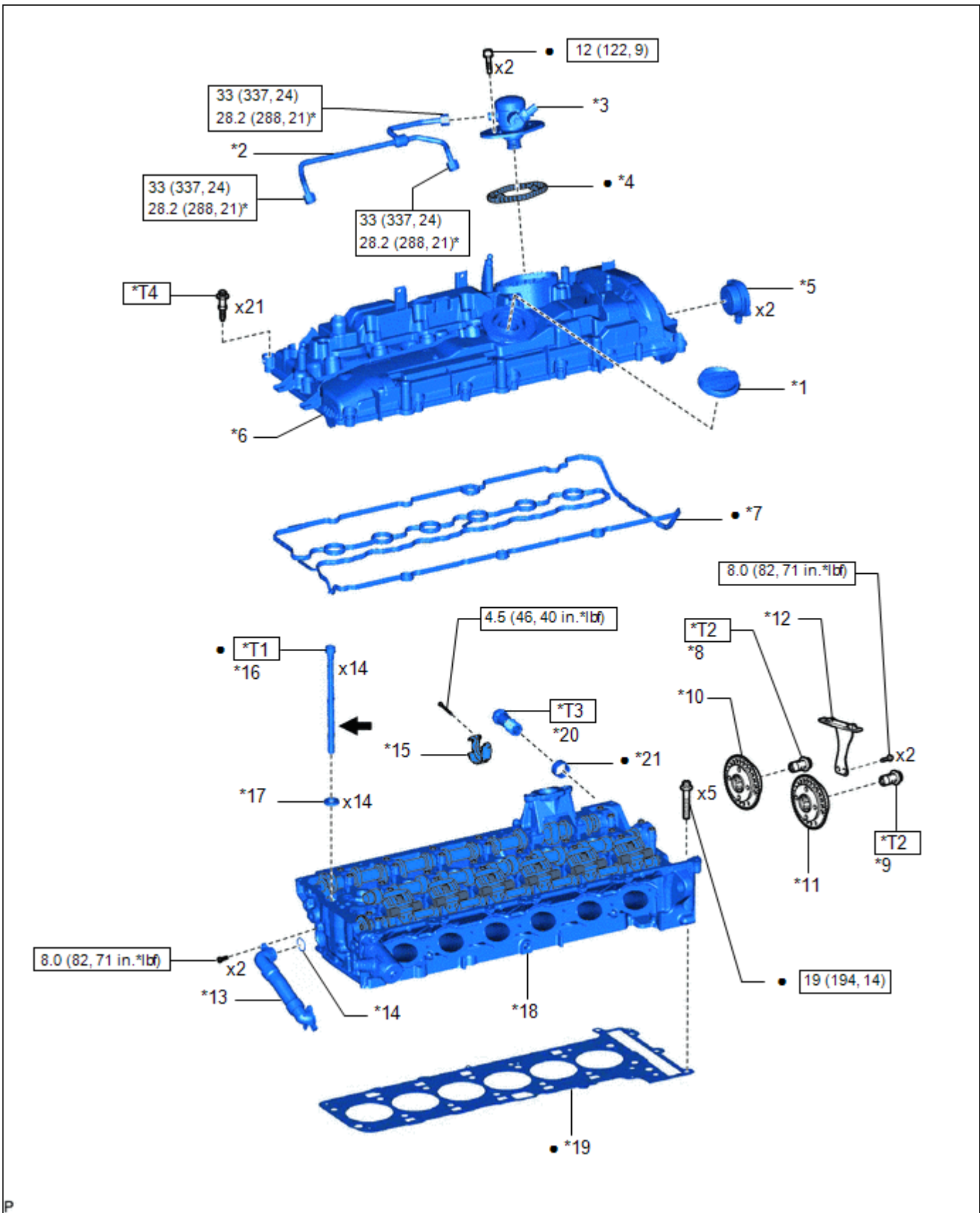

*1	TURBO OIL INLET PIPE SUB-ASSEMBLY	*2	TURBO OIL OUTLET PIPE
*3	TURBOCHARGER STAY	*4	O-RING
	N*m (kgf*cm, ft.*lbf): Specified torque	•	Non-reusable part

ILLUSTRATION





P

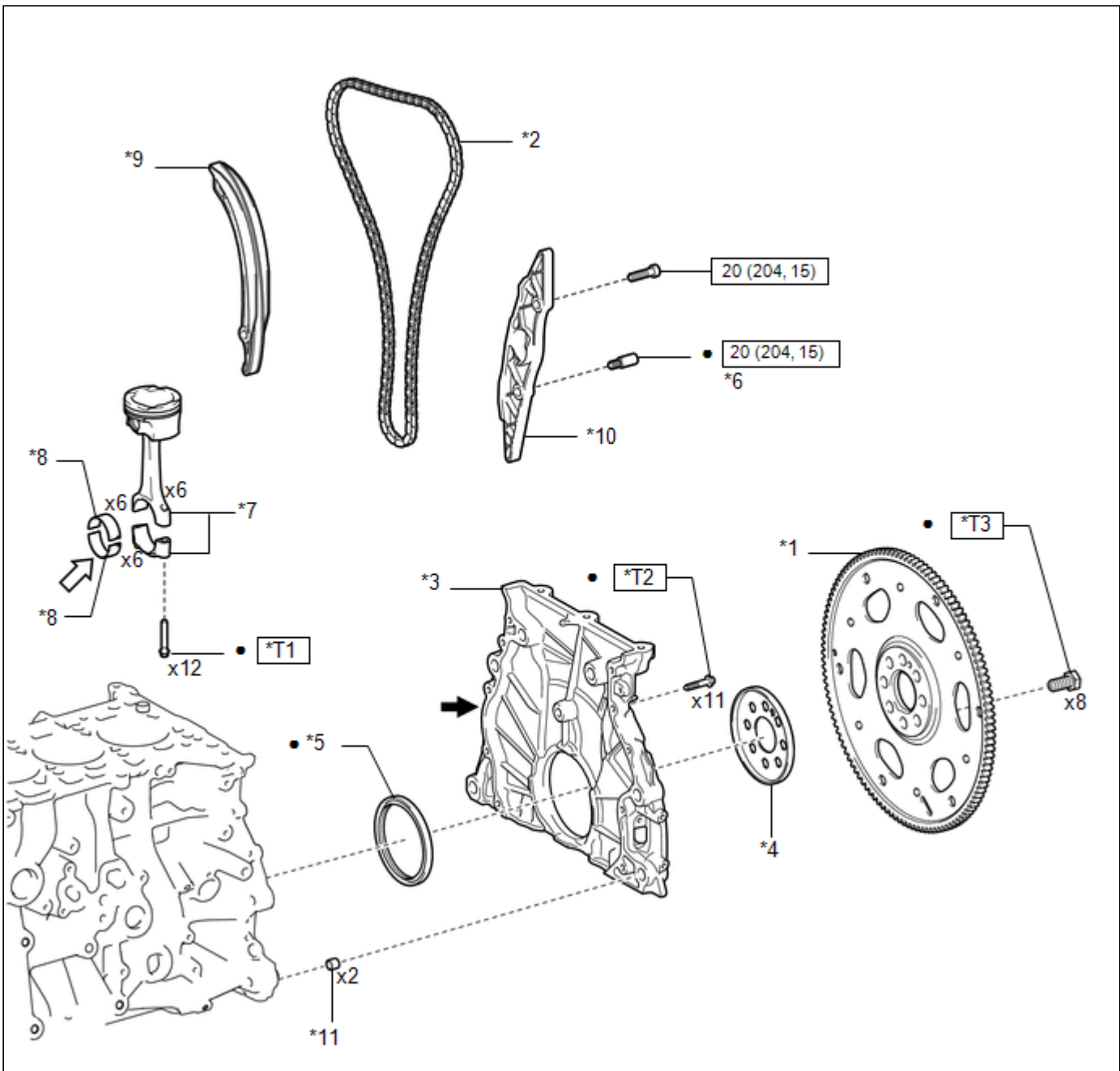

*1	OIL FILLER CAP ASSEMBLY	*2	NO. 1 FUEL PIPE SUB-ASSEMBLY
*3	FUEL PUMP ASSEMBLY	*4	FUEL PUMP SPACER GASKET
*5	CAM TIMING OIL CONTROL SOLENOID ASSEMBLY	*6	CYLINDER HEAD COVER SUB-ASSEMBLY
*7	CYLINDER HEAD COVER GASKET	*8	EXHAUST CAMSHAFT TIMING GEAR

			CENTER BOLT ASSEMBLY
*9	INTAKE CAMSHAFT TIMING GEAR CENTER BOLT ASSEMBLY	*10	CAMSHAFT TIMING EXHAUST GEAR ASSEMBLY
*11	CAMSHAFT TIMING GEAR ASSEMBLY	*12	CHAIN DAMPER GUIDE
*13	NO. 2 WATER BY-PASS HOSE	*14	O-RING
*15	CAMSHAFT SENSOR WHEEL	*16	CYLINDER HEAD SET BOLT
*17	PLATE WASHER	*18	CYLINDER HEAD SUB-ASSEMBLY
*19	CYLINDER HEAD GASKET	*20	NO. 1 CHAIN TENSIONER ASSEMBLY
*21	SEALING SLEEVE	-	-
	N*m (kgf*cm, ft.*lbf): Specified torque	*	For use with a union nut wrench
•	Non-reusable part		Engine oil
*T1	1st: 30 (306, 22) 2nd: Turn 90° 3rd: Turn 180°	*T2	1st: 10 (102, 7) 2nd: 30 (306, 22) 3rd : 50 (510, 37) 4th : Turn 35°
*T3	1st: 20 (204, 15) 2nd: Turn 40°	*T4	1st: 6.0 (61, 53 in.*lbf) 2nd: 11 (112, 8)

ILLUSTRATION



*1	FLYWHEEL SUB-ASSEMBLY	*2	CHAIN SUB-ASSEMBLY
*3	TIMING GEAR CASE	*4	NO. 1 CRANK ANGLE SENSOR PLATE
*5	TIMING CHAIN COVER OIL SEAL	*6	BEARING JOURNAL
*7	PISTON SUB-ASSEMBLY W/PIN	*8	CONNECTING ROD BEARING
*9	CHAIN TENSIONER SLIPPER	*10	NO. 1 CHAIN VIBRATION DAMPER
*11	RING PIN	-	-
	N*m (kgf*cm, ft.*lbf): Specified torque	•	Non-reusable part
	Loctite 5970 Flange Sealant		Engine oil

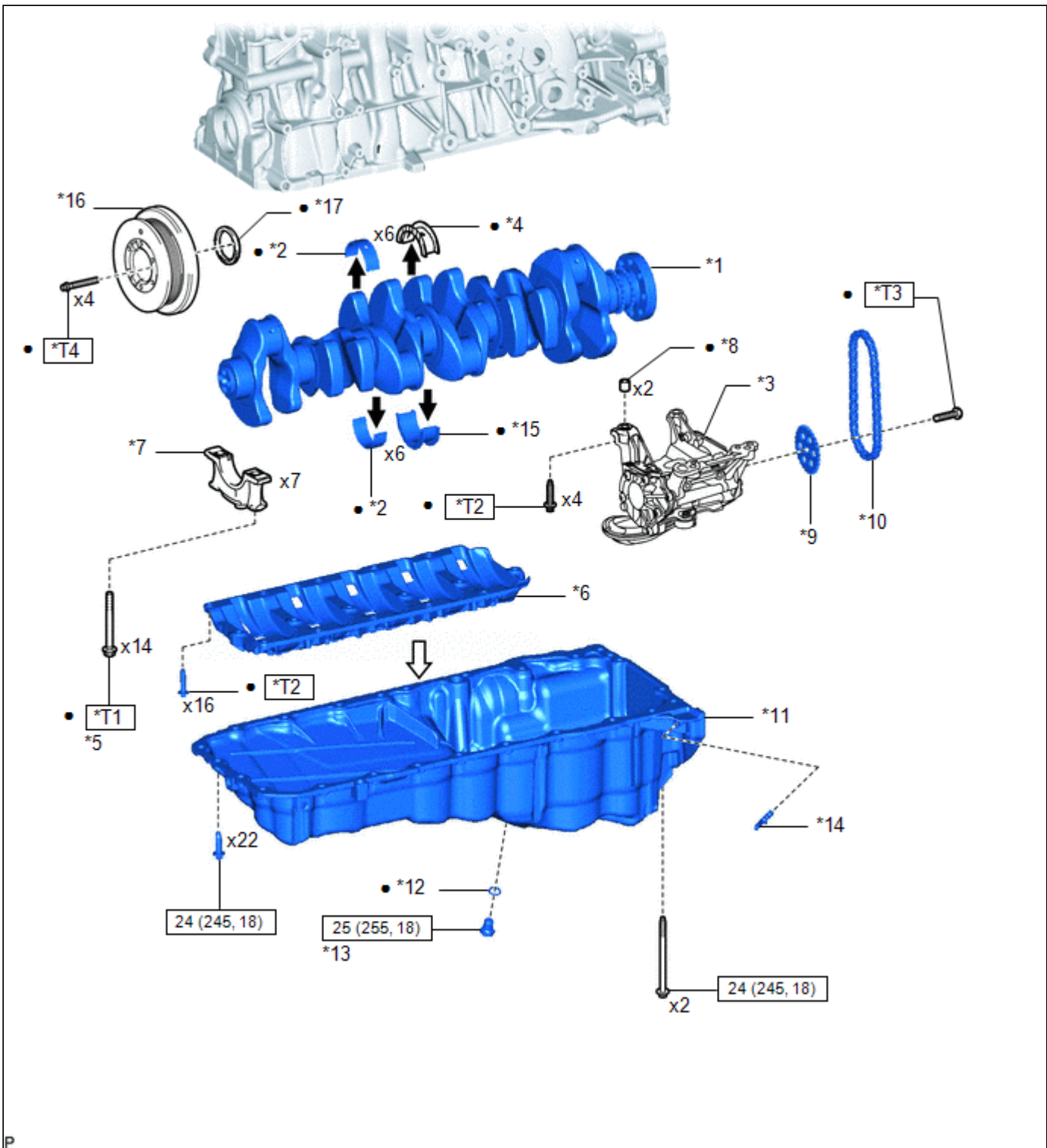

			
*T1	1st: 20 (204, 15) 2nd: Turn 70° 3rd: Turn 70°	*T2	1st: 8.0 (82, 71 in.*lbf) 2nd: Turn 90°
*T3	1st: 45 (459, 33) 2nd: Turn 40°	-	-

ILLUSTRATION



P

*1	CRANKSHAFT	*2	CRANKSHAFT BEARING
*3	OIL PUMP ASSEMBLY	*4	UPPER CRANKSHAFT THRUST WASHER
*5	CRANKSHAFT BEARING CAP SET BOLT	*6	NO. 1 OIL PAN BAFFLE PLATE
*7	CRANKSHAFT BEARING CAP	*8	OIL PUMP SET PIN
*9	CAMSHAFT SPROCKET	*10	OIL PUMP DRIVE CHAIN SUB-ASSEMBLY
*11	OIL PAN SUB-ASSEMBLY	*12	OIL PAN DRAIN PLUG GASKET

*13	OIL PAN DRAIN PLUG	*14	SEAL CAP
*15	LOWER CRANKSHAFT THRUST WASHER	*16	CRANKSHAFT PULLEY ASSEMBLY
*17	FRONT CRANKSHAFT OIL SEAL	-	-
	N*m (kgf*cm, ft.*lbf): Specified torque	•	Non-reusable part
	Engine oil		Loctite 5970 Flange Sealant
*T1	1st: 25 (255, 18) 2nd: Turn 65° 3rd: Turn 65°	*T2	1st: 15 (153, 11) 2nd: Turn 45°
*T3	1st: 5.0 (51, 44 in.*lbf) 2nd: Turn 90°	*T4	1st: 40 (408, 30) 2nd: Turn 120°

