

QF Cut-in Branch

Ø mm	O/D mm	I/D mm	Rolled Edge (nom. mm.)	Thickness mm
80	79	78	6	0.7
100	98	97	6	
125	124	123	6	
140	139	138	6	
150	148	147	6	
160	159	158	6	
180	179	178	8	
200	200	199	8	
224	224	223	8	
250	250	249	8	
300	298	297	10	
315	313	312	10	
350	348	347	10	
400	400	398	10	
450	449	447	10	
500	499	497	10	
560	559	557	10	
630	629	627	10	
710	709	707	10	

Ends

Standard QF end can be changed to Raw ID (I/D), Raw OD (O/D), Hose Adapter (FX), Flat Bar Flange (FL), or 6mm turned out edge (FB).

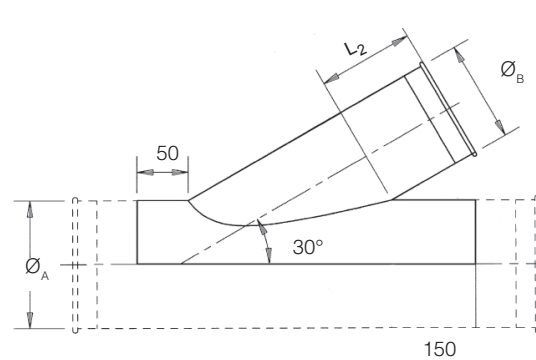

$$L2 = (\text{Ø}_B / 2) + 58$$

Ø_B must be smaller than or equal to Ø_A



Construction

Seam: longitudinal seam is lapped, spot welded, and caulked.

Collars: located on the exterior side of each port and considered as air flow non-directional. Collars have lapped, spot welded and caulked longitudinal seam.

If air flow directional product is required, it must be stated on the PO and additional cost may be incurred. A raised lap seam and **spot weld are used for attaching the collar to the body and no caulking is used. If caulking is required, additional cost may be incurred.**

Temperature Rating of Product Components			Compliance / Rating of Product Components		
° C	Cut-in Branch	Sealants	Product	Material	Compliance / Rating
200°	Galvanised Steel		Cut-in Branch	Galvanised	DX51D with Z275 Coating
121°		Joka Seal Metal Sealant 2315	Joka Seal Metal Sealant 2315	Acetone blend	AAMA Specification 801.1
-20°					

Additional Notes

At temperatures ranging between 200° C and 250° C, the zinc-iron alloy layers in galvanised steel will continue to provide a high level of protection from corrosion. However, there may be some peeling, changes in mechanical properties, and reduction in the corrosion protection. Recommended max. service temperature is 200° C.