

Ø mm	A mm	B mm	C mm	D mm	E mm	Weight kg	Galvanised Steel
080	397	197	133	185	254	3,0	0,9
100	509	217		220	289	3,0	
125	564	242		248	316	3,5	
140	619	257		275	344	4,0	
150	629	267		280	349	4,0	
160	679	227		305	374	4,5	
180	739	297		335	404	5,0	
200	799	317		365	434	6,0	
224	883	341		407	476	6,5	
250	949	367		440	509	7,5	
300	1099	417		515	584	9,5	
315	1144	432		538	606	10,0	
350	1279	467		605	674	11,5	
400	1429	517		680	749	14,0	

Ends
Standard QF end can be changed to Raw ID (I/D), Raw OD (O/D), Hose Adapter (FX), Flat Bar Flange (FL), or 6mm turned out edge (FB).

Note:
The SBMS type energy saving damper is a manually operated blast gate or sliding damper.

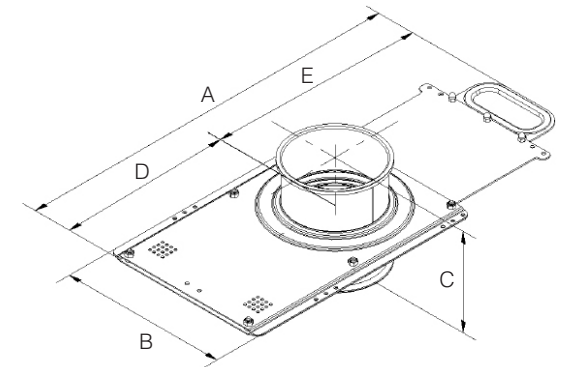
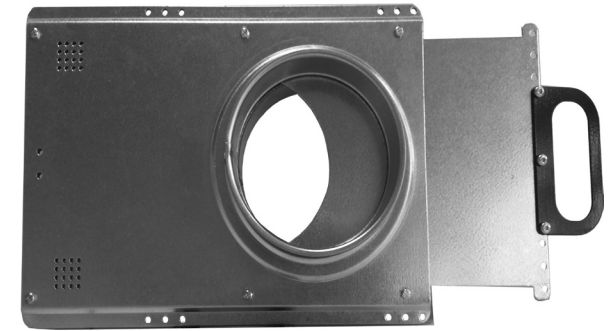

Temperature Rating of Product Components		
° C	SBMS Manual Damper	Sealants
200°	Galvanised Steel	Joka Seal Metal Sealant 2315
121°		
-20°		

Compliance / Rating of Product Components		
Product	Material	Compliance / Rating
SBMS Manual Damper	Galvanised	DX51D with Z275 Coating
Joka Seal Metal Sealant 2315	Acetone blend	AAMA Specification 801.1

Additional Notes

At temperatures ranging between 200° C and 250° C, the zinc-iron alloy layers in galvanised steel will continue to provide a high level of protection from corrosion. However, there may be some peeling, changes in mechanical properties, and reduction in the corrosion protection. Recommended max. service temperature is 200° C.