

## Dealer's Manual

ROAD	MTB	Trekking
City Touring/ Comfort Bike	URBAN SPORT	E-BIKE

# SHIFTING LEVER

## **XTR**

SL-M9100

## **DEORE XT**

SL-M8100

## **SLX**

SL-M7100

## **Seat post lever**

SL-MT800

# CONTENTS

---

<b>CONTENTS .....</b>	<b>2</b>
<b>IMPORTANT NOTICE .....</b>	<b>3</b>
<b>TO ENSURE SAFETY .....</b>	<b>4</b>
<b>LIST OF TOOLS TO BE USED .....</b>	<b>7</b>
<b>INSTALLATION/REMOVAL .....</b>	<b>8</b>
<b>Installing the shifting lever .....</b>	<b>8</b>
• Standard type .....	8
• I-SPEC EV .....	9
<b>Installing the seat post lever .....</b>	<b>12</b>
<b>ADJUSTMENT .....</b>	<b>17</b>
<b>Adjusting the stopped lever position (MONO lever) .....</b>	<b>17</b>
• SL-M9100 .....	18
• SL-M8100/SL-M7100 .....	19
<b>MAINTENANCE .....</b>	<b>20</b>
<b>Replacing the inner cable .....</b>	<b>20</b>
• Shifting lever .....	20
• Shifting lever (MONO lever) .....	21
• Seat Post Lever .....	23
<b>Replacing the shifting lever unit .....</b>	<b>25</b>
<b>Replacing the lever pad (Shifting lever) .....</b>	<b>29</b>
• SL-M9100 .....	29
• SL-M8100 .....	30

# IMPORTANT NOTICE

- **This dealer's manual is intended primarily for use by professional bicycle mechanics.**  
Users who are not professionally trained for bicycle assembly should not attempt to install the components themselves using the dealer's manuals.  
If any part of the information on the manual is unclear to you, do not proceed with the installation. Instead, contact your place of purchase or a bicycle dealer for their assistance.
- Make sure to read all manuals included with the product.
- Do not disassemble or modify the product other than as stated in the information contained in this dealer's manual.
- All manuals and technical documents are accessible online at <https://si.shimano.com>.
- For consumers who do not have easy access to the internet, please contact a SHIMANO distributor or any of the SHIMANO offices to obtain a hardcopy of the User's Manual.
- Please observe the appropriate rules and regulations of the country, state or region in which you conduct your business as a dealer.

**For safety, be sure to read this dealer's manual thoroughly before use, and follow it for correct use.**

The following instructions must be observed at all times in order to prevent personal injury and physical damage to equipment and surroundings.

The instructions are classified according to the degree of danger or damage which may occur if the product is used incorrectly.

 <b>DANGER</b>	Failure to follow the instructions will result in death or serious injury.
 <b>WARNING</b>	Failure to follow the instructions could result in death or serious injury.
 <b>CAUTION</b>	Failure to follow the instructions could cause personal injury or physical damage to equipment and surroundings.

# TO ENSURE SAFETY

## **WARNING**

- **Be sure to follow the instructions provided in the manuals when installing the product.**  
Only use SHIMANO genuine parts. If a component or replacement part is incorrectly assembled or adjusted, it can lead to component failure and cause the rider to lose control and crash.
-  Wear approved eye protection while performing maintenance tasks such as replacing components.

## **NOTICE**

### **Be sure to also inform users of the following:**

- Be sure to keep turning the crank arm during the shifting lever operation.
- If gear shifting operations do not feel smooth, wash the shifting unit and lubricate all moving parts.
- Products are not guaranteed against natural wear and deterioration from normal use and aging.
- For maximum performance we highly recommend SHIMANO lubricants and maintenance products.

### **For installation to the bicycle, and maintenance:**

- Grease the inner cable and the sliding portions of the outer casing before use to ensure that they slide properly.
- Use an OT-SP41 cable and a cable guide (SM-SP17/SP18) for smooth operation.
- A special grease is used for the gear shifting cable. Do not use Premium Grease or other types of grease, otherwise, they may cause deterioration in gear shifting performance.
- Use an outer casing which still has some length to spare even when the handlebars are turned all the way to either side. Furthermore, check that the shifting lever does not touch the bicycle frame when the handlebars are turned all the way.
- If gear shifting adjustments cannot be carried out, check the alignment of the dropout and check if the cable is lubricated or if the outer casing is too long or too short.

• List of cables used

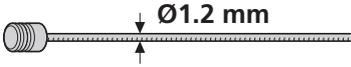
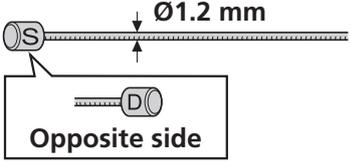
	Designated inner cable	Recommended outer casing
SL-M9100		SP41 outer casing 
SL-M8100 SL-M7100 SL-MT800		

\* Refer to the list of recommended outer caps.

\* Do not let dust adhere on the inner cable. If the grease on the inner cable is wiped off, the application of SIS SP41 grease (Y04180000) is recommended.

- List of recommended outer caps (SL-M9100/SL-M8100/SL-M7100)

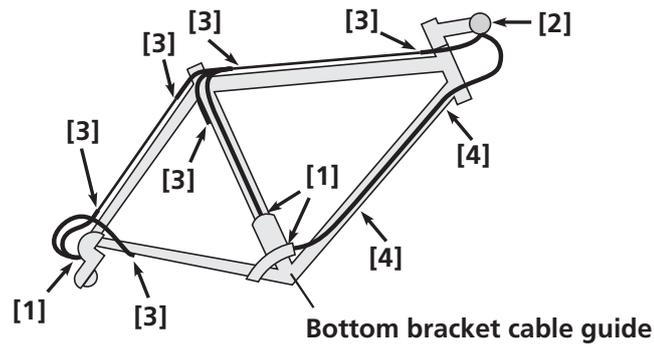

[1]	[2]	[3]	[4]
 <b>A</b>	 <b>B</b>	 <b>C</b>	 <b>D</b>
 <b>or B</b>		 <b>D</b>	 <b>E</b>

Type of outer cap		Remarks
<b>A</b>	Sealed outer cap (aluminum type)	FD/RD side It is recommended if the outer casing moves to a large degree, such as in bicycles with a suspension frame
<b>B</b>	Sealed outer cap (resin type)	Shifting lever/FD/RD side
<b>C</b>	Sealed outer cap with tongue	Outer casing holder on frame side
<b>D</b>	Rubber shield	
<b>E</b>	Outer cap with long tongue	Recommended for bikes with internal cable routing where there is not a straight angle and/or the inner cable contacts the frame material where it enters the frame

- The recommended outer cap of SL-MT800 is a sealed outer cap (resin type) on both the lever side and seat post side.

The actual product may differ from the illustration because this manual is intended mainly to explain the procedures for using the product.

# LIST OF TOOLS TO BE USED

The following tools are needed for installation/removal, adjustment, and maintenance purposes.

Tool	
	2 mm hexagon wrench
	2.5 mm hexagon wrench
	3 mm hexagon wrench
	4 mm hexagon wrench
	Cross head screwdriver [#0]
	Cross head screwdriver [#1]
	Cross head screwdriver [#2]
	Slotted screwdriver (width 4.5 - 5.5 mm)
	TL-CT12

# INSTALLATION/REMOVAL

## Installing the shifting lever

When installing parts onto a carbon frame/handlebar, confirm the recommended tightening torque with the carbon frame or handlebar manufacturer. This will prevent damage to the frame/handlebar due to over-torquing or inadequate securing of the components.

### Standard type

#### 1. Tighten the mounting bolt.

Use a handlebar grip with a maximum outer diameter of  $\varnothing 32$  mm or less ( $\varnothing 36$  mm or less for SL-M7100).

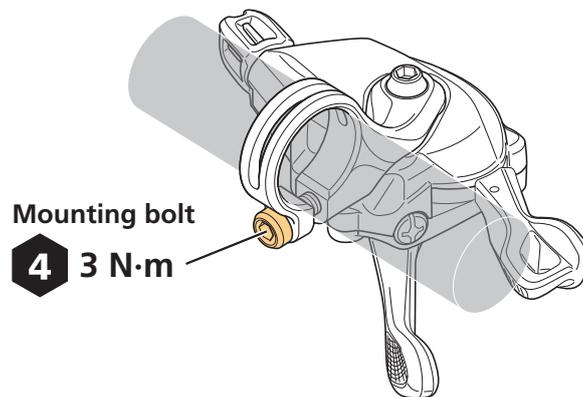

#### **NOTICE**

- Check that the brake and gear shifting operations are not obstructed.



## I-SPEC EV

For information on brake levers that can be installed, check the compatibility information (<https://productinfo.shimano.com>).

### 1. Open the clamp band of the brake lever.

- (1) Loosen the mounting bolt.
- (2) Press the recessed area of the clamp band with a tool such as a 2 mm hexagon wrench to disengage the safety latch.

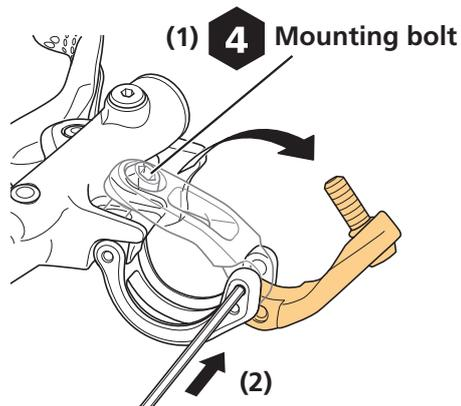

## 2. Temporarily attach the shifting lever to the clamp band.

Temporarily install with the unit position adjustment bolt as shown in the figure. Make sure to firmly install the unit position adjustment nut to the clamp band.

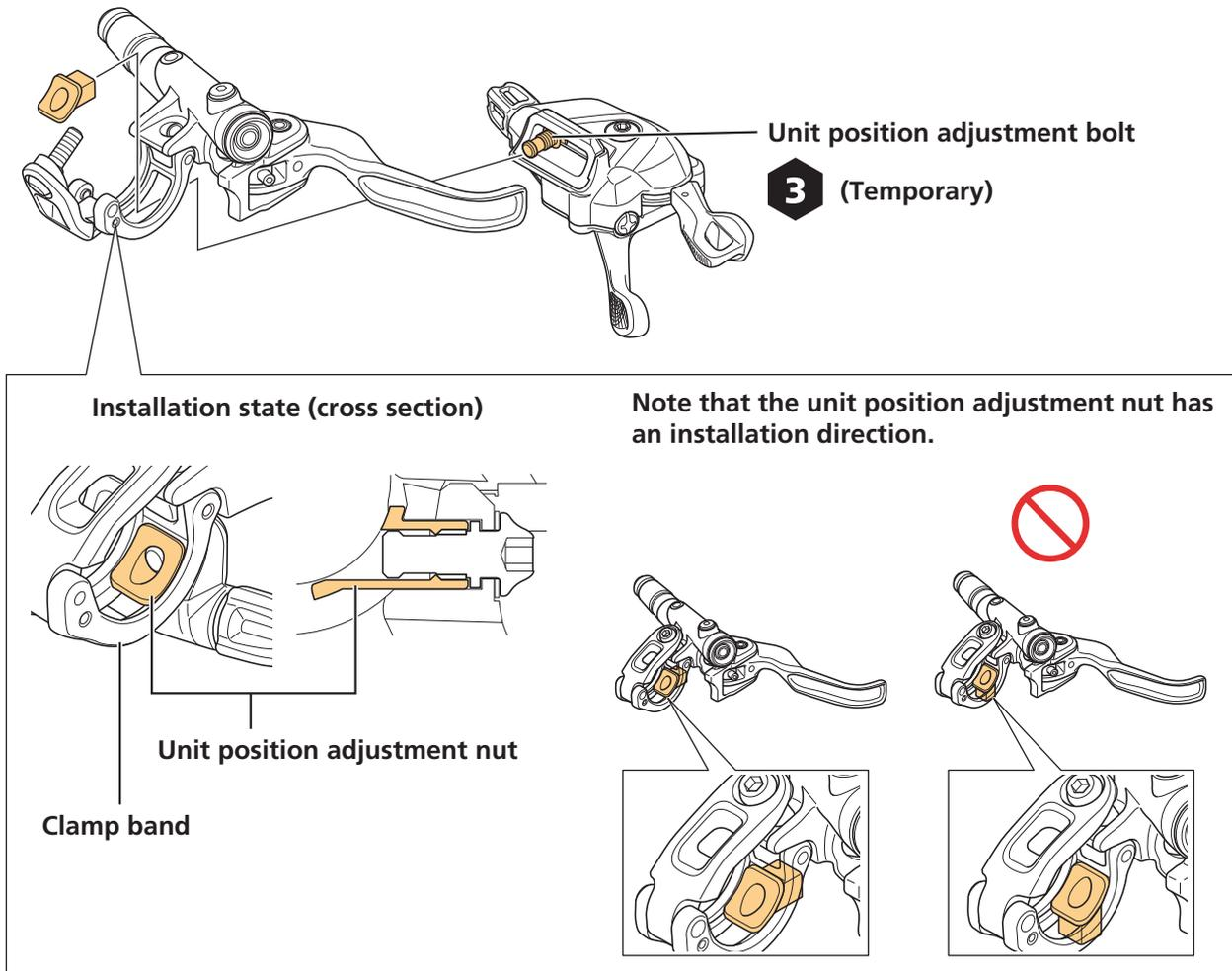

## 3. Pull an O-ring to the clamp band side as shown in the figure.

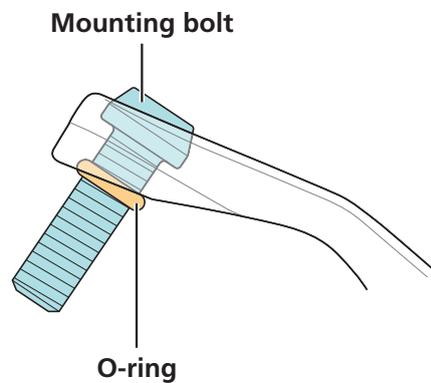

## 4. Attach the brake lever to the handlebar.

Secure the lever using the mounting bolt.

Mounting bolt

**4** 4 - 6 N·m

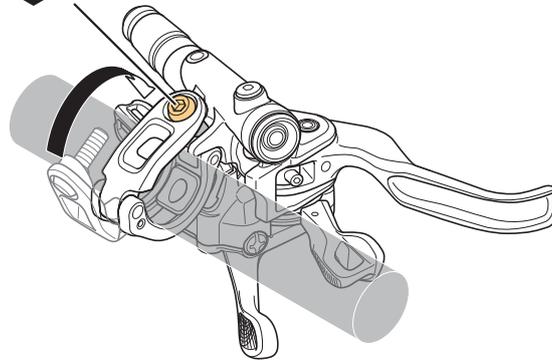

## 5. Adjust the position of the shifting lever.

Adjust the shifting lever by sliding it vertically or horizontally.

If it is difficult to slide the shifting lever, loosen the unit position adjustment bolt.

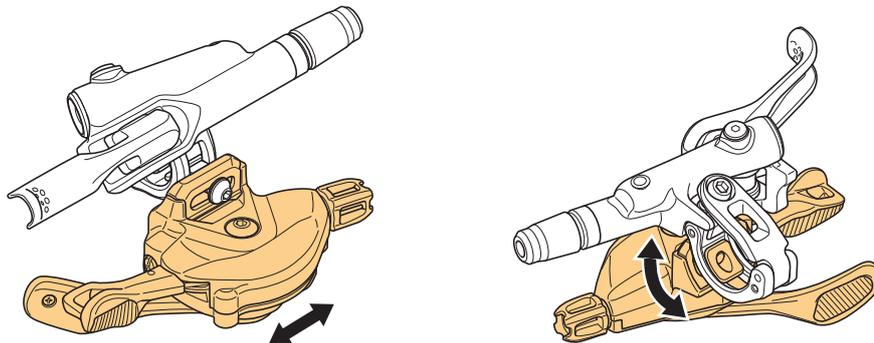

### TECH TIPS

- To remove it, loosen the unit position adjustment bolt while pulling the main body of the shifting lever away from the brake lever. Since the thread of the unit position adjustment bolt is cut off midway to prevent detachment, it is necessary to pull the main body of the shifting lever away from the brake lever.

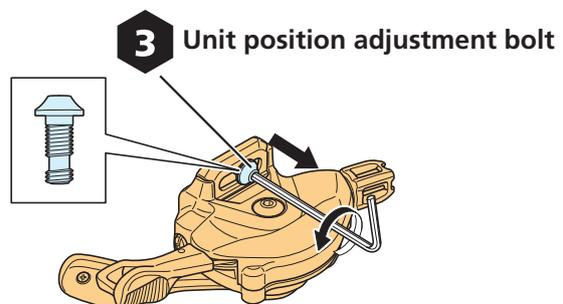

## 6. Tighten the unit position adjustment bolt.

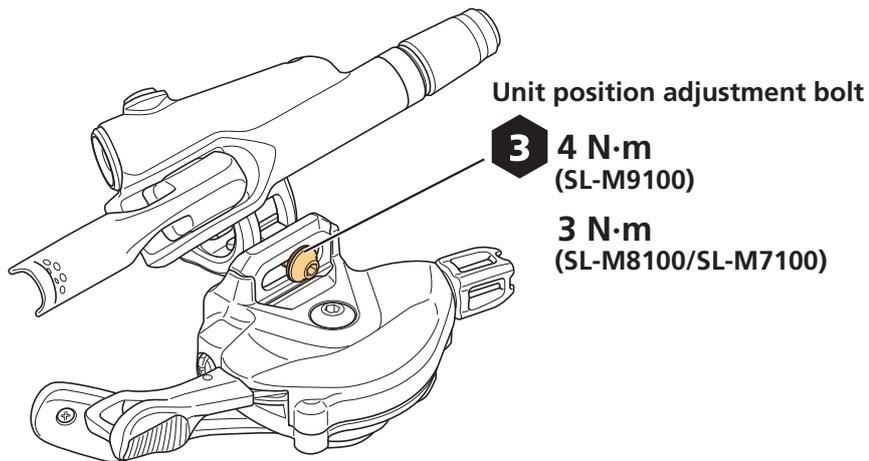

# Installing the seat post lever

For information on brake levers that can be installed, check the compatibility information (<https://productinfo.shimano.com>).

## 1. Open the clamp band of the brake lever.

- (1) Loosen the mounting bolt.
- (2) Press the recessed area of the clamp band with a tool such as a 2 mm hexagon wrench to disengage the safety latch.

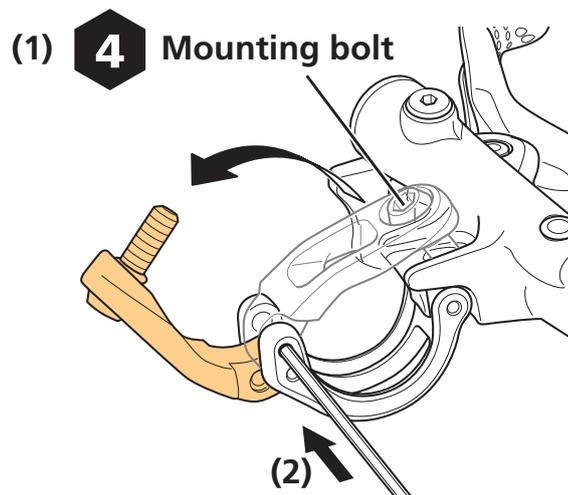

## 2. Temporarily attach the seat post lever to the clamp band.

Temporarily install with the unit position adjustment bolt as shown in the figure. Make sure to firmly install the unit position adjustment nut to the clamp band.

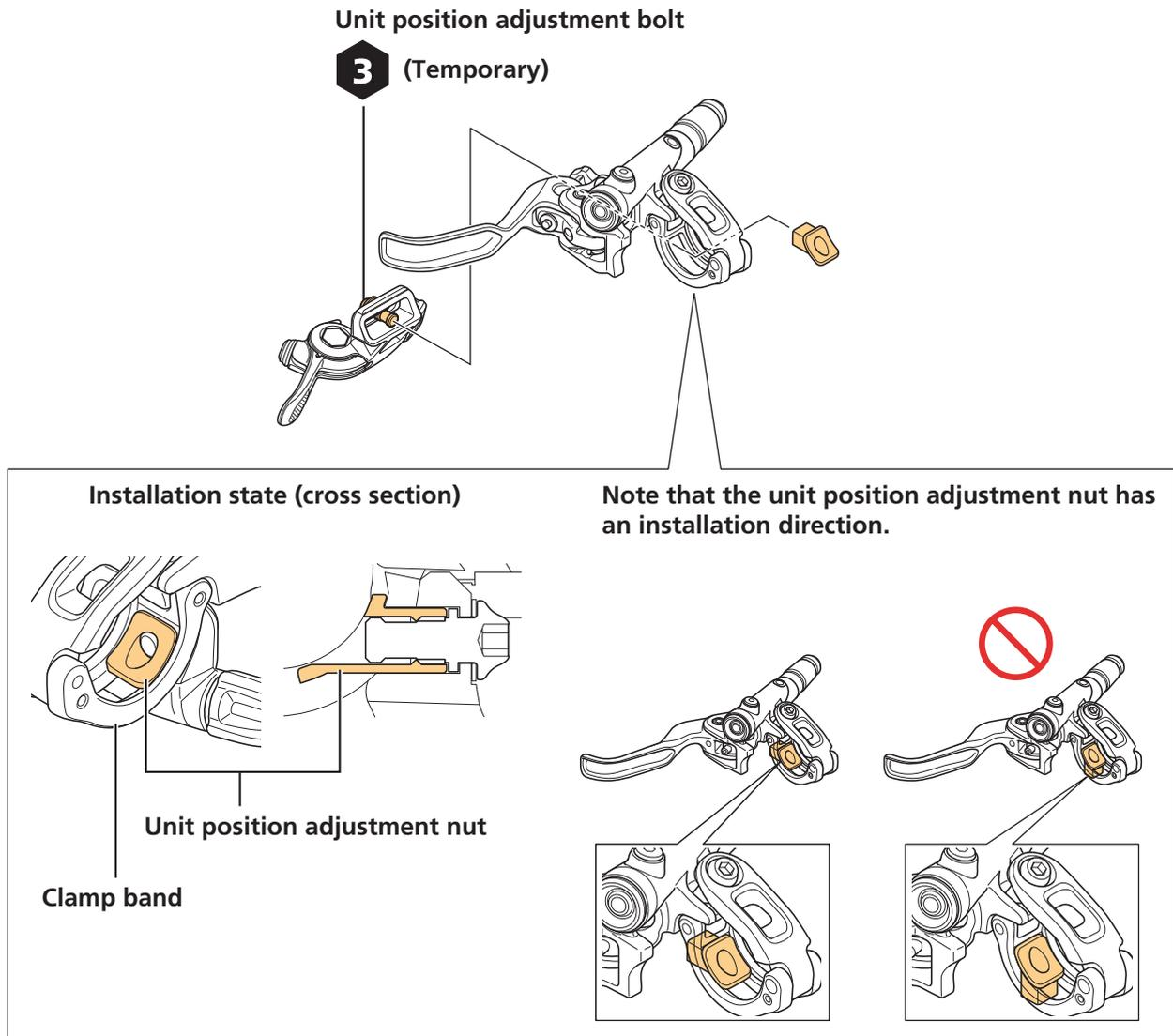

## 3. Pull an O-ring to the clamp band side as shown in the figure.

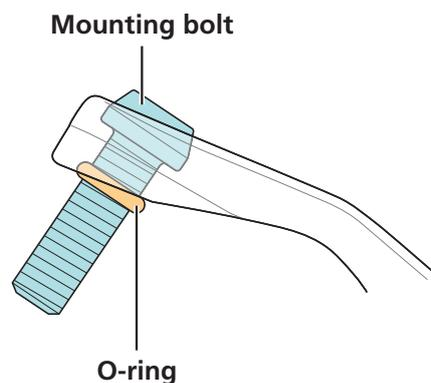

## 4. Attach the brake lever to the handlebar.

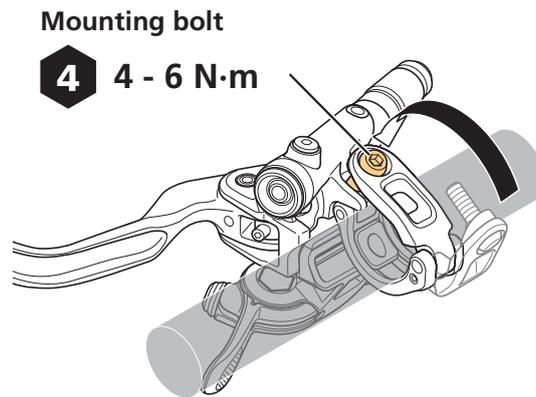

## 5. Adjust the position of the seat post lever.

Adjust the seat post lever by sliding it vertically or horizontally.

If it is difficult to slide the seat post lever, loosen the unit position adjustment bolt.

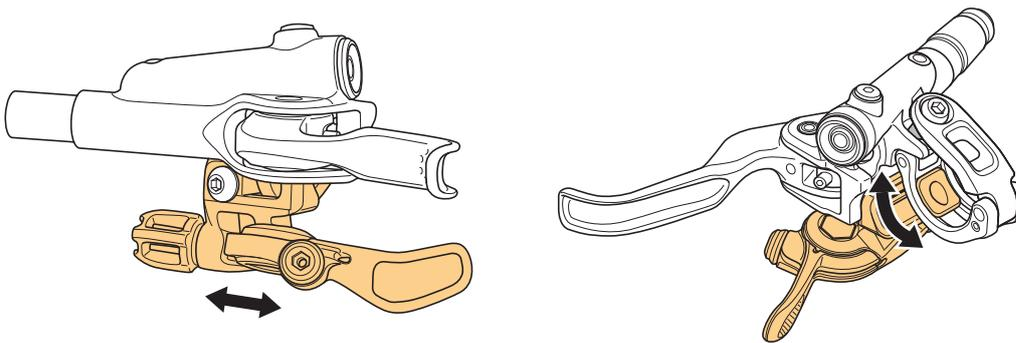

### TECH TIPS

- To remove it, loosen the unit position adjustment bolt while pulling the main body of the seat post lever away from the brake lever. Since the thread of the unit position adjustment bolt is cut off midway to prevent detachment, it is necessary to pull the main body of the seat post lever away from the brake lever.

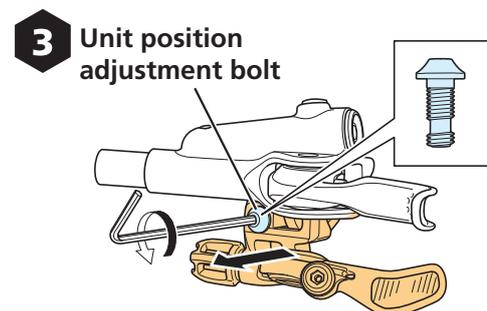

## 6. Tighten the unit position adjustment bolt.

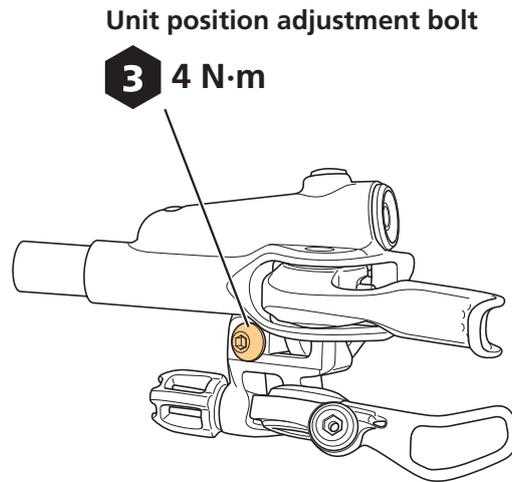

## 7. Set the inner cable.

Pass the inner cable through along the cable fixing groove on the top of the cable fixing bolt.

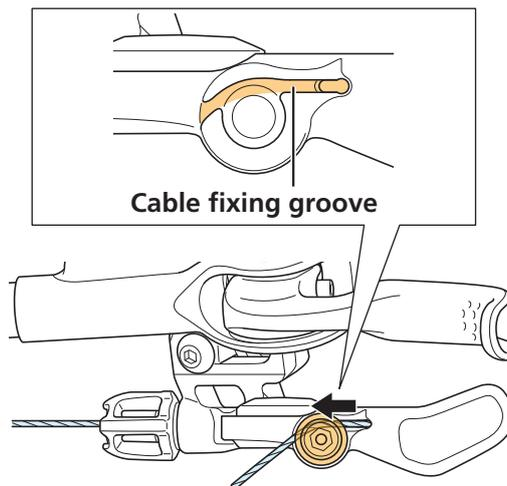

## 8. Tighten the cable fixing bolt.

While pulling the inner cable, tighten the cable fixing bolt.

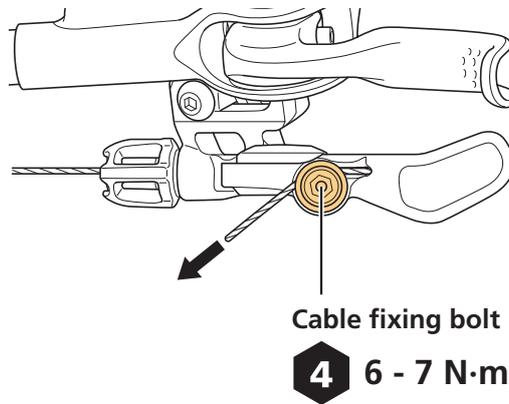

## 9. Cut the inner cable so that the protruding length is 12 - 15 mm.

Use TL-CT12 to cut the inner cable.

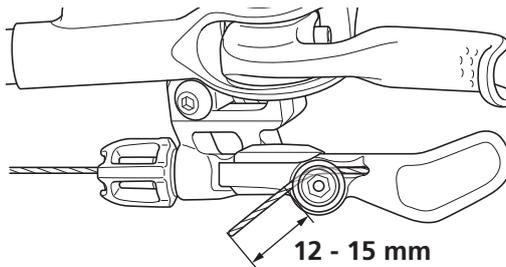

## 10. Install the inner end cap.

Use TL-CT12 to crimp the inner end cap.

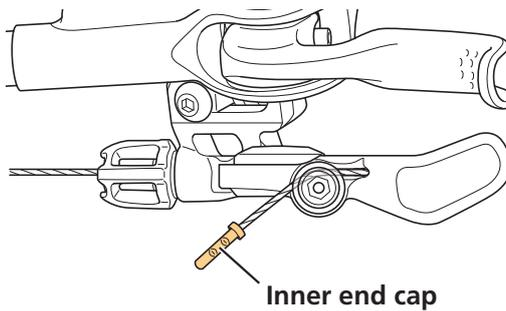



# ADJUSTMENT

## Adjusting the stopped lever position (MONO lever)

The stopped lever position can be adjusted. After lever operation, the lever is kept in the adjusted position. If the lever is operated again, the lever returns to its initial position.

### **⚠ CAUTION**

- Adjusting the stopped lever position must only be done after returning the lever to its initial position. If the adjuster is moved during lever operation, the lever may be damaged.

# SL-M9100

## 1. Turn the adjuster with a slotted screwdriver while pushing it in.

Turn it with a slotted screwdriver (width 4.5 - 5.5 mm).

After adjustment, check whether the adjuster that was pushed in has returned to its original height.

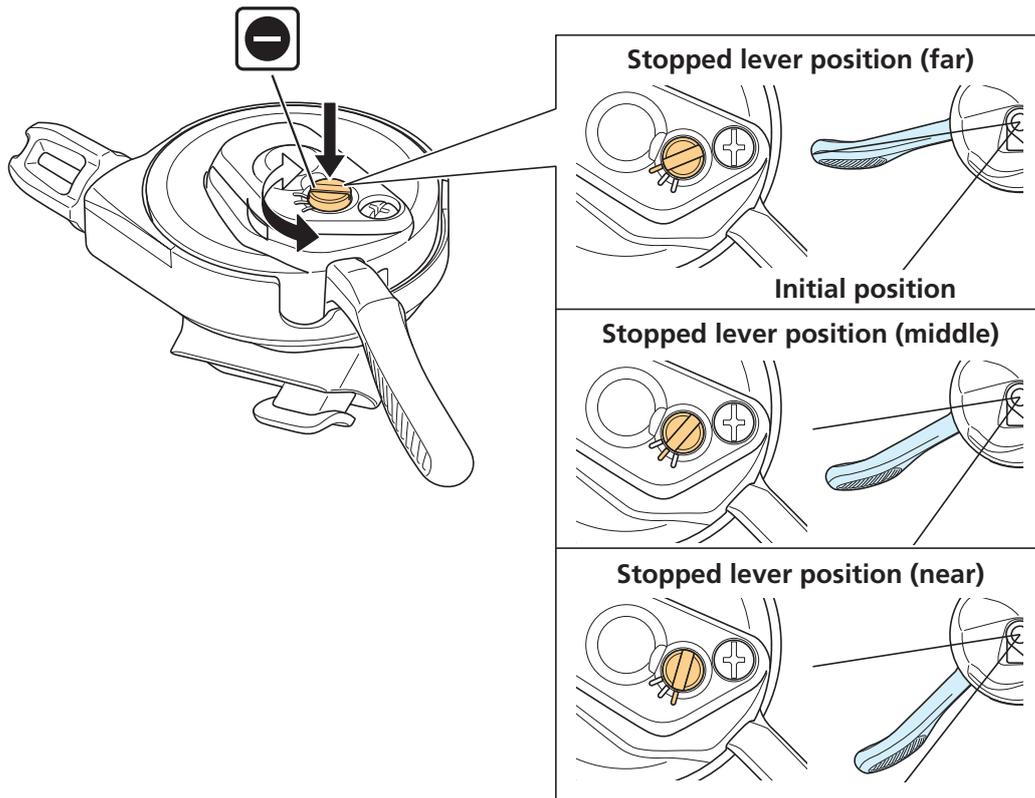

## SL-M8100/SL-M7100

**1. Turn the adjuster while pushing it towards the lever body.**

The stopped lever position changes based on the position of the recessed area of the adjuster.

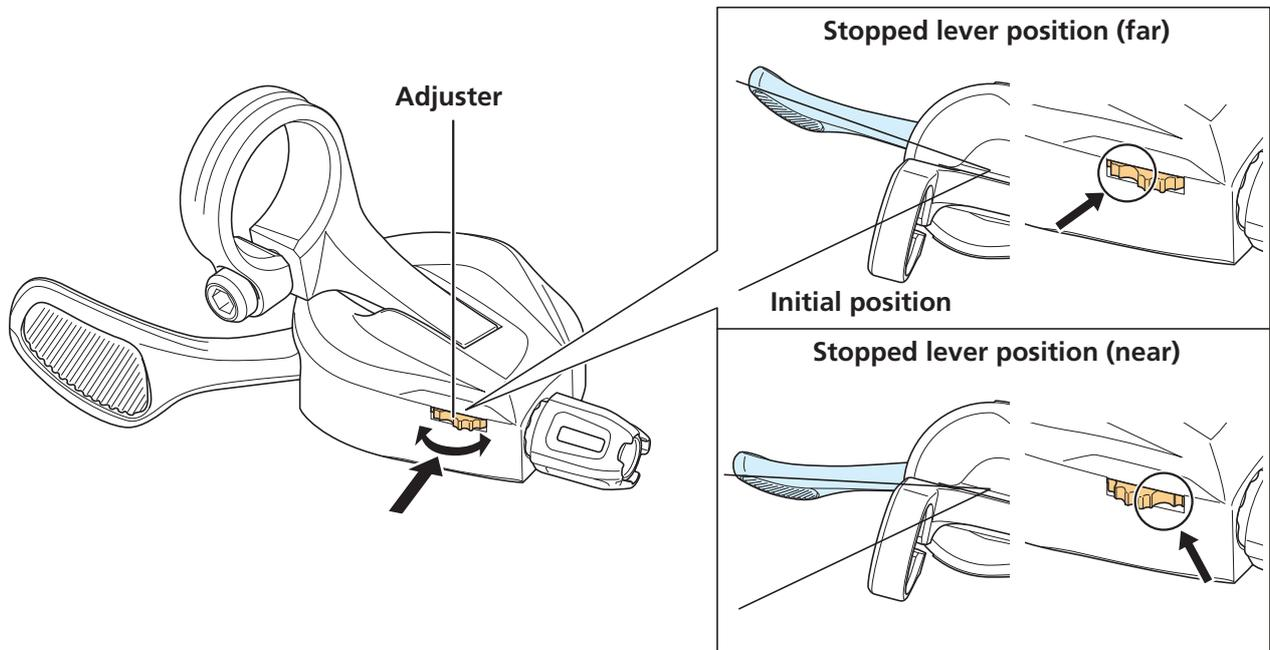

# MAINTENANCE

## Replacing the inner cable

Before beginning the replacement tasks, loosen the cable fixing bolts (nuts) of the front derailleur, rear derailleur, and seat post.

### Shifting lever

#### 1. Set the shifting lever in its initial position.

Operate the release lever 11 or more times for a 12-speed and 10 or more times for an 11-speed.

#### 2. Remove the inner hole cap.

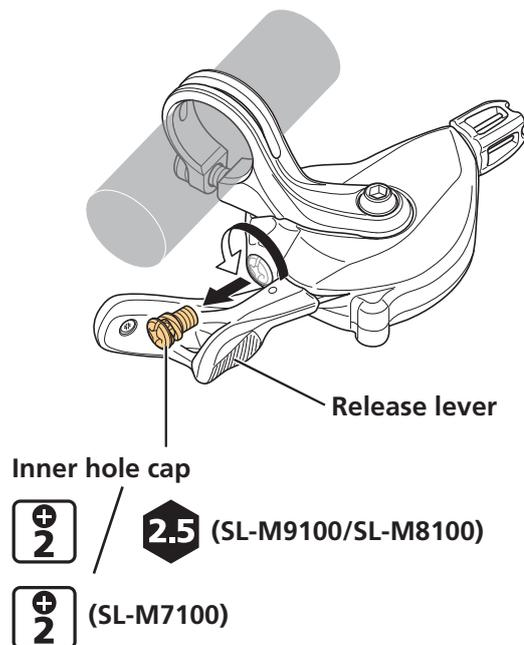

### 3. Replace the inner cable and install an inner hole cap.

Turn and stop the inner hole cap at the position shown in the figure. If you force it to turn, it may damage the screw thread on the cap.

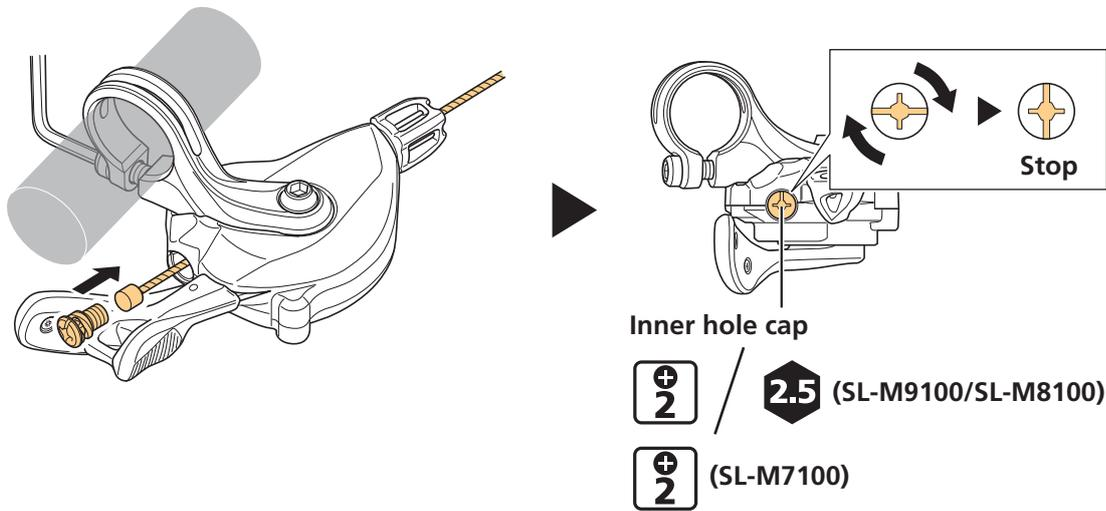

## Shifting lever (MONO lever)

### 1. Set the lever in its initial position.

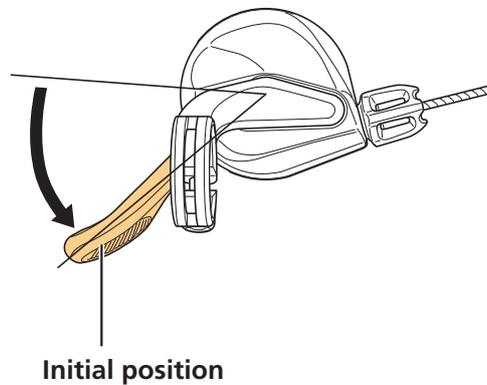

## 2. Loosen the cover mounting bolt.

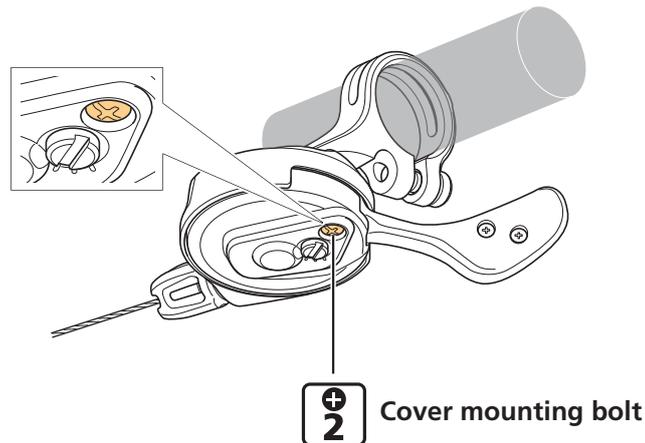

## 3. Move the cover and remove the inner cable.

The cover does not completely come off. Remove the inner cable from the gap made by moving the cover.

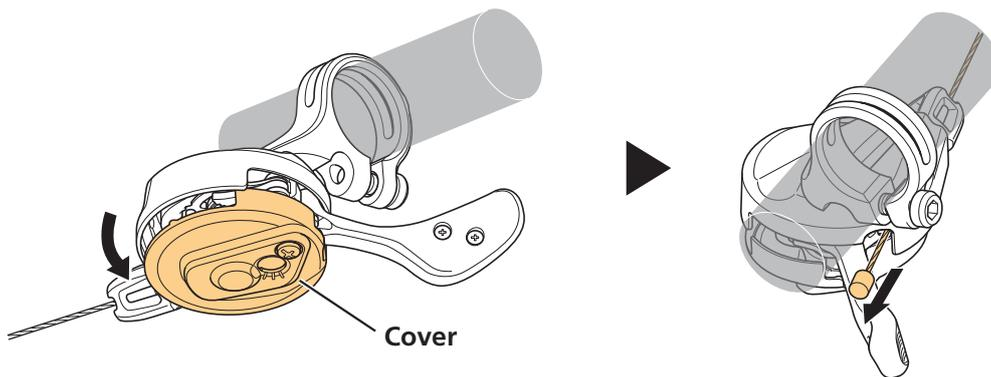

### **NOTICE**

- If you pull too firmly on the cover, the drop prevention tab may be damaged.

## 4. Install the inner cable.

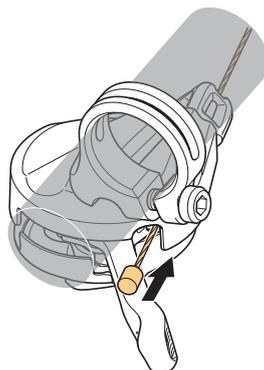

**5. Install the cover in the reverse order of disassembly.**

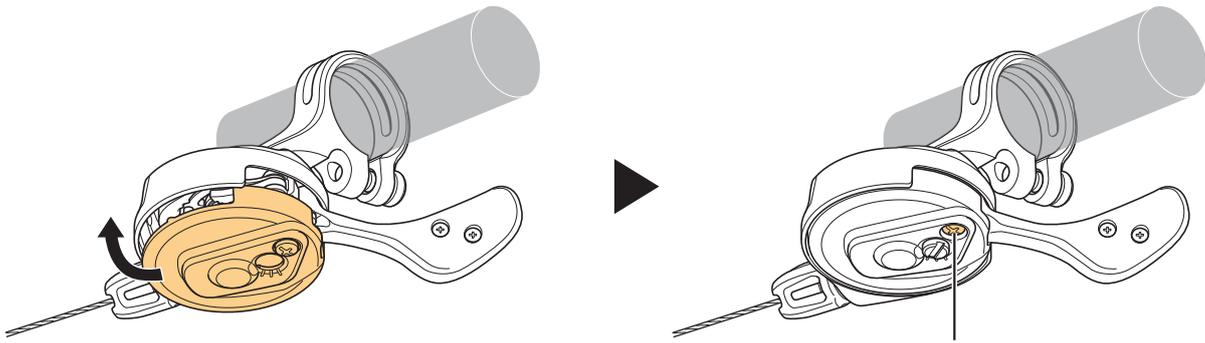

Cover mounting bolt

**2** 0.3 N·m

\* The SL-M7100 uses a self tapping screw designed for assembly into plastic. Don't use any other screws.

## Seat Post Lever

**1. Separate the inner end cap.**

Cut the inner cable with TL-CT12.

**2. Loosen the cable fixing bolt and remove the inner cable.**

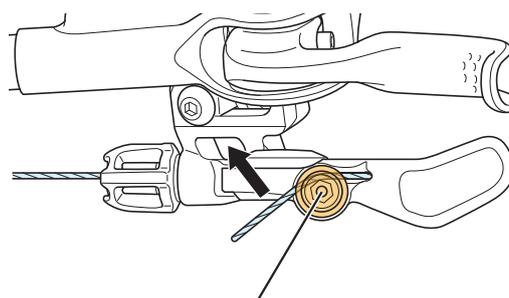

**4** Cable fixing bolt

### 3. Set the inner cable.

Pass the inner cable through along the cable fixing groove on the top of the cable fixing bolt.

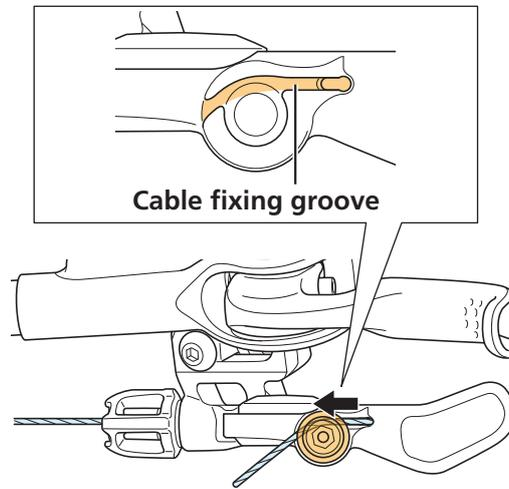

### 4. Tighten the cable fixing bolt.

While pulling the inner cable, tighten the cable fixing bolt.

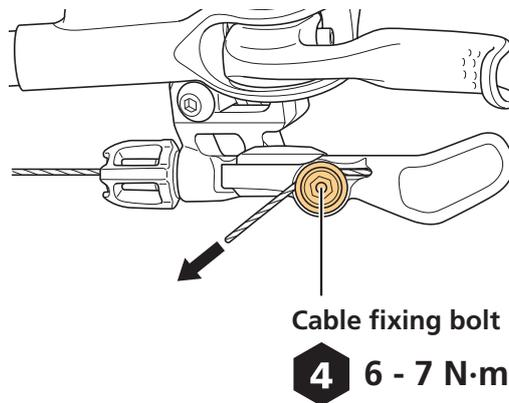

### 5. Cut the inner cable so that the protruding length is 12 - 15 mm.

Use TL-CT12 to cut the inner cable.

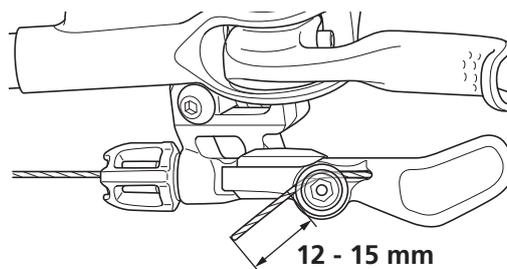



## 6. Install the inner end cap.

Use TL-CT12 to crimp the inner end cap.

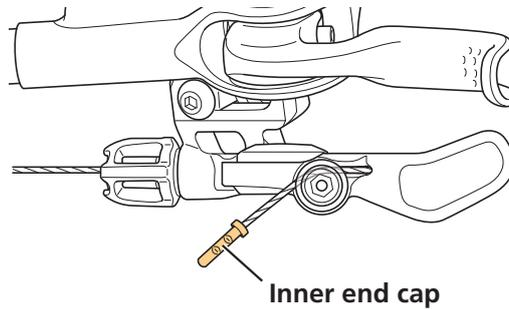

# Replacing the shifting lever unit

Disassembly and assembly should only be conducted when replacing the shifting lever unit.

\* The MONO lever unit cannot be replaced.

## 1. Remove the inner cable.

Follow the same instructions used in the replacement procedure.

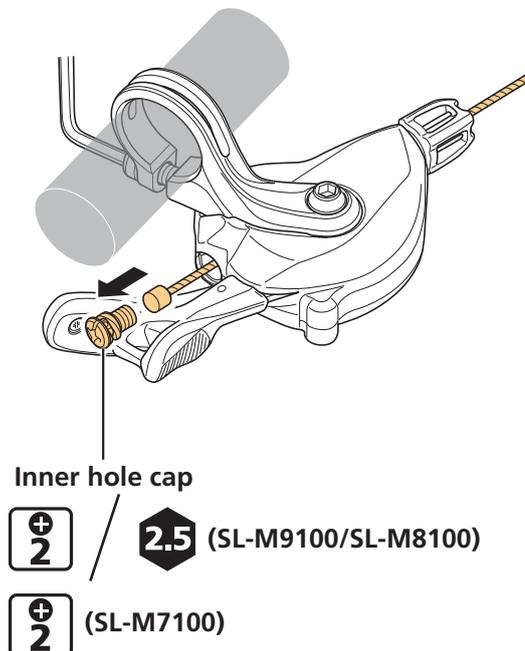

## 2. Remove the cable adjustment barrel.

Loosen by hand and remove the cable adjustment barrel.

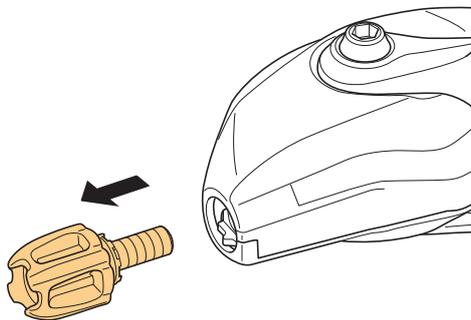

## 3. Remove the unit fixing bolt.

Standard type

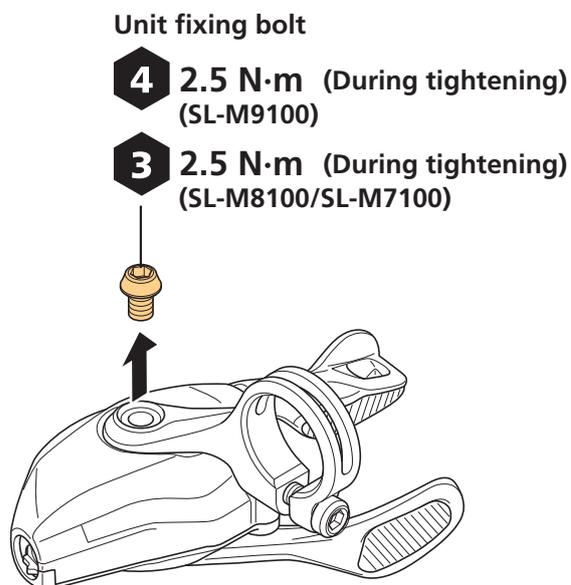

I-SPEC EV

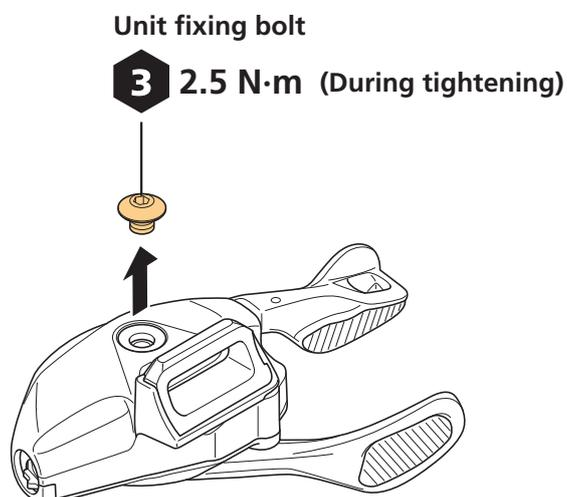

## 4. Remove the shifting lever unit.

(1) Remove the three mounting screws.

(2) Remove the cover.

\* Perform the installation of the shifting lever unit in the reverse order from the removal procedure.

SL-M9100/SL-M8100

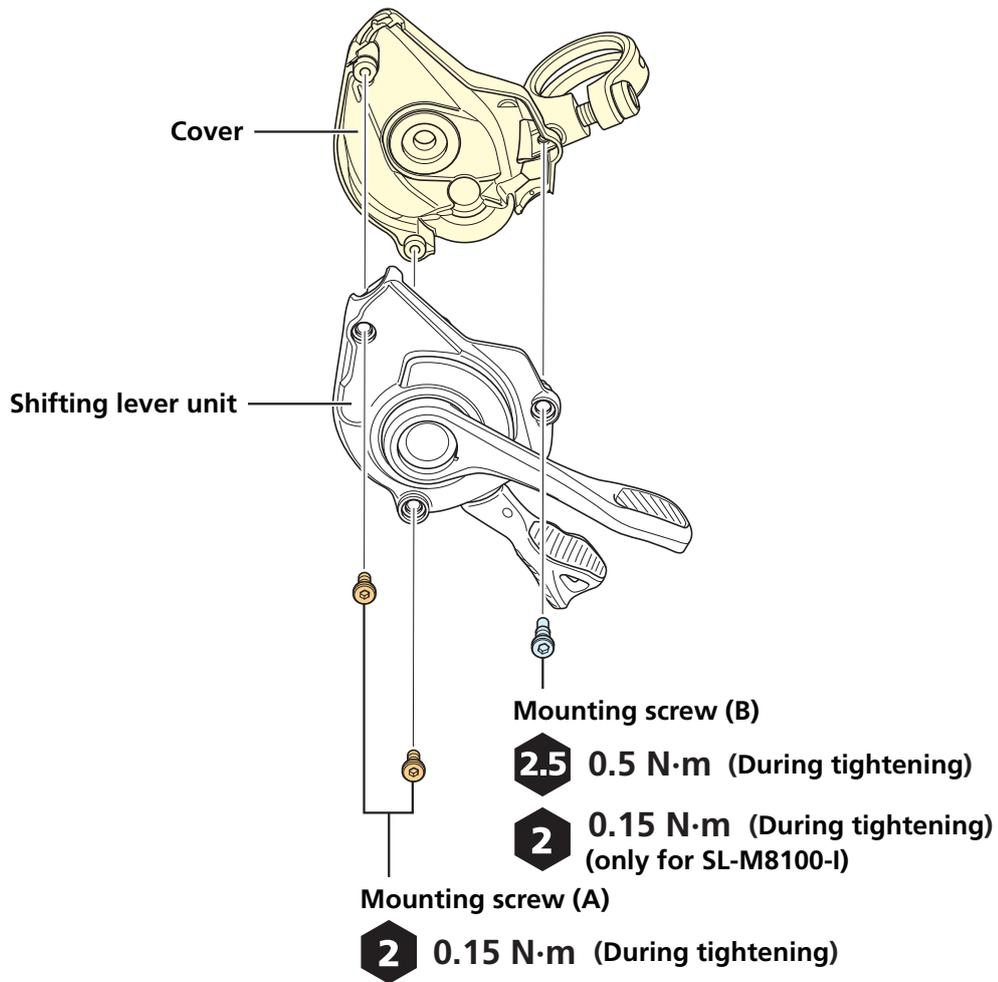

### NOTICE

- Only for SL-M8100-I does a mounting screw (B) become a self tapping screw.

SL-M7100

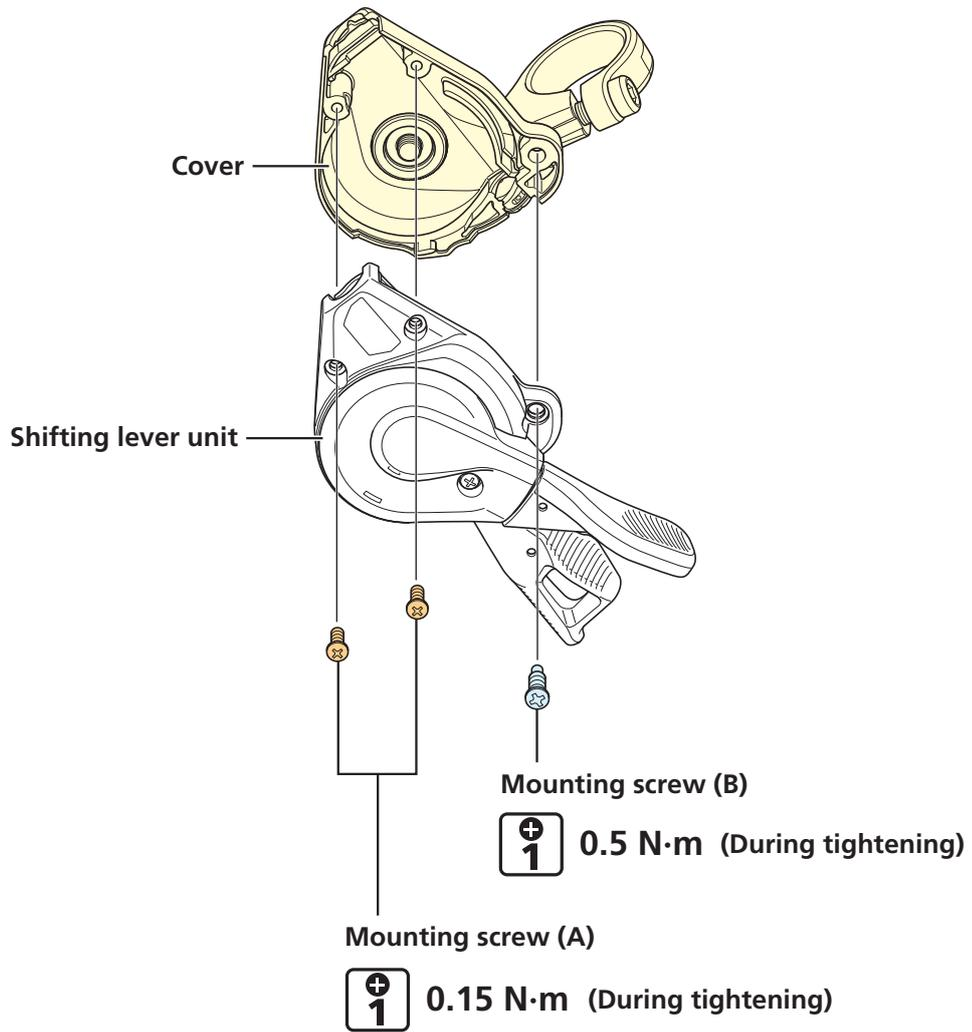

# Replacing the lever pad (Shifting lever)

There is no lever pad for SL-M7100.

## NOTICE

- Be sure to use the specified screwdriver size when installing/removing the pad mounting bolts. If a screwdriver size other than the one specified is used, the pad mounting bolts may be damaged.

## SL-M9100

### 1. Remove the pad mounting bolts.

Remove two pad mounting bolts.

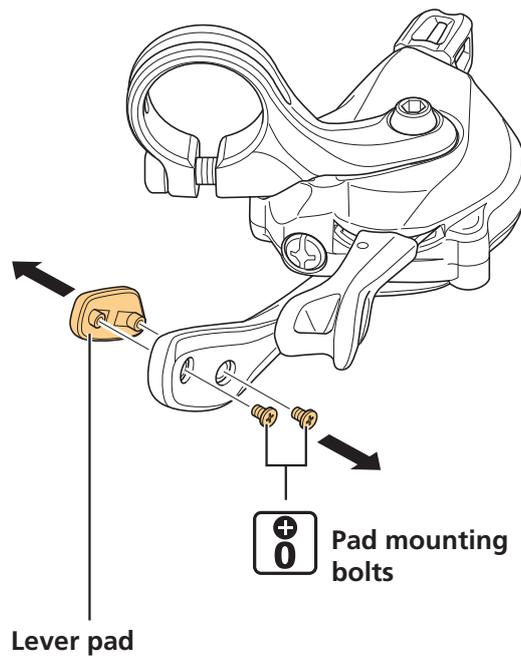

## 2. Replace the lever pad and tighten the pad mounting bolts.

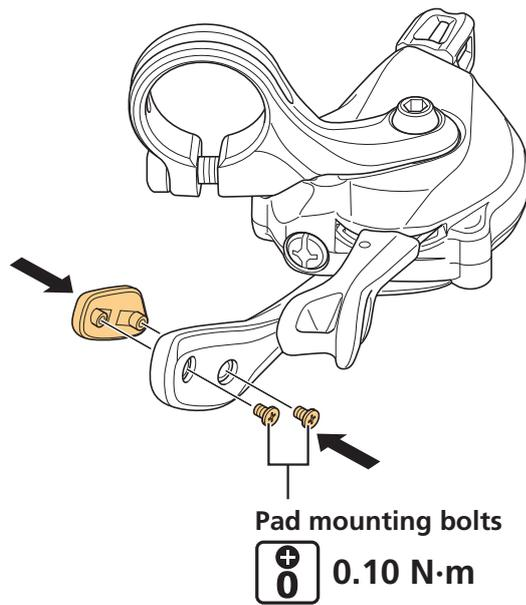

## SL-M8100

### 1. Remove lever pad.

Use a 2 mm hexagon wrench on the three holes on the inner side of the lever to push out the lever pad.

### 2. Install the new lever pad.

Insert the protrusions (three locations) of the lever pad into the holes in the lever. After it is inserted, check that it is firmly attached.

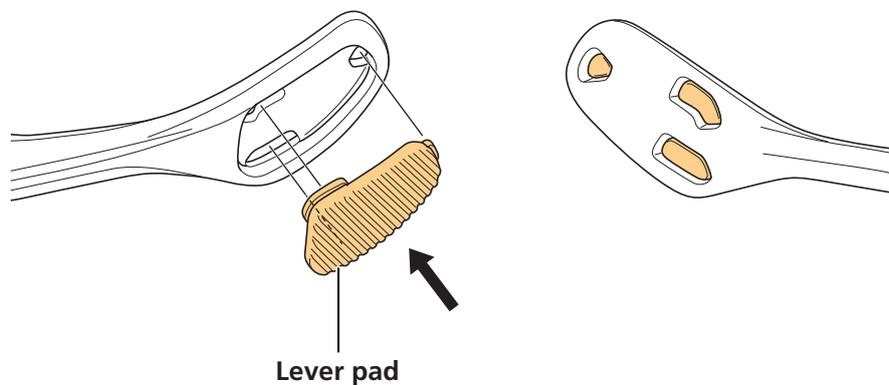

# SHIMANO

**SHIMANO NORTH AMERICA BICYCLE, INC.**

One Holland, Irvine, California 92618, U.S.A. Phone: +1-949-951-5003

**SHIMANO EUROPE B.V.**

High Tech Campus 92, 5656 AG Eindhoven, The Netherlands Phone: +31-402-612222

**SHIMANO INC.**

3-77 Oimatsu-cho, Sakai-ku, Sakai City, Osaka 590-8577, Japan

Please note: specifications are subject to change for improvement without notice. (English)

© Jul. 2019 by SHIMANO INC. ITP