

Dealer's Manual

ROAD	MTB	Trekking
City Touring/ Comfort Bike	URBAN SPORT	E-BIKE

REAR DERAILLEUR

XTR

RD-M9100

RD-M9120

DEORE XT

RD-M8100

RD-M8120

SLX

RD-M7100

RD-M7120

DEORE

RD-M6100

RD-M5100

CONTENTS



CONTENTS	2
IMPORTANT NOTICE	3
TO ENSURE SAFETY	4
LIST OF TOOLS TO BE USED	6
INSTALLATION/REMOVAL	7
Installing the rear derailleur.....	7
ADJUSTMENT	9
Adjusting the stroke on the high limit	9
Installing the chain.....	10
Checking the chain length.....	10
Connection and securing of the inner cable	13
• Outer casing length.....	13
• Connection and securing of the inner cable	15
Adjusting the stroke on the low limit	18
Adjusting the B-screw.....	19
SIS adjustment.....	21
MAINTENANCE	23
Replacing the pulleys.....	23
Replacing the B-axle	24
Replacing the bumper.....	25
Applying grease to the chain stabilizer.....	26
Adjusting friction	28
• Friction adjustment	28
Replacing the plate, plate tension spring, and switch lever.....	31
• Removal	31
• Installation	35

IMPORTANT NOTICE

- **This dealer's manual is intended primarily for use by professional bicycle mechanics.**
Users who are not professionally trained for bicycle assembly should not attempt to install the components themselves using the dealer's manuals.
If any part of the information on the manual is unclear to you, do not proceed with the installation. Instead, contact your place of purchase or a distributor for assistance.
- Make sure to read all manuals included with the product.
- Do not disassemble or modify the product other than as stated in the information contained in this dealer's manual.
- All manuals and technical documents are accessible online at <https://si.shimano.com>.
- For consumers who do not have easy access to the internet, please contact a SHIMANO distributor or any of the SHIMANO offices to obtain a hardcopy of the User's Manual.
- Please observe the appropriate rules and regulations of the country, state or region in which you conduct your business as a dealer.

For safety, be sure to read this dealer's manual thoroughly before use, and follow it for correct use.

The following instructions must be observed at all times in order to prevent personal injury and physical damage to equipment and surroundings.
The instructions are classified according to the degree of danger or damage which may occur if the product is used incorrectly.

 DANGER	Failure to follow the instructions will result in death or serious injury.
 WARNING	Failure to follow the instructions could result in death or serious injury.
 CAUTION	Failure to follow the instructions could cause personal injury or physical damage to equipment and surroundings.

TO ENSURE SAFETY

WARNING

- **Be sure to follow the instructions provided in the manuals when installing the product.**
Only use SHIMANO genuine parts. If a component or replacement part is incorrectly assembled or adjusted, it can lead to component failure and cause the rider to lose control and crash.
-  Wear approved eye protection while performing maintenance tasks such as replacing components.

Be sure to also inform users of the following:

- Clean the chain and QUICK-LINK with an appropriate chain cleaner regularly. Intervals between maintenance depend on the use and riding circumstances. Never use alkali based or acid based solvents such as rust cleaners. If those solvents are used the chain or QUICK-LINK might break and cause serious injury.
- Check the chain for any damage (deformation or cracking), skipping, or other abnormalities such as unintended gear shifting. If any problems are found, consult your place of purchase or a distributor. The chain may break, and you may fall.

NOTICE

Be sure to also inform users of the following:

- For SHADOW RD+, be sure to check that the plate unit cover and the plate unit rubber cap are installed before riding the bicycle.
- If gear shifting operation does not feel smooth, consult the place of purchase for assistance.
- Products are not guaranteed against natural wear and deterioration from normal use and aging.
- For maximum performance we highly recommend SHIMANO lubricants and maintenance products.







For installation to the bicycle, and maintenance:

- Depending on the shape of the frame, the rear derailleur may interfere with the chainstay.
- Grease with SIS SP41 grease (Y04180000) the inner cable and the sliding portions of the outer casing before use to ensure that they slide properly. Do not let dust adhere to the inner cable.
- Use an OT-SP41 outer casing and a cable guide (SM-SP17/SP18) for smooth operation.
- Use an outer casing which still has some length to spare even when the handlebars are turned all the way to either side. Furthermore, check that the shifting lever does not touch the bicycle frame when the handlebars are turned all the way.
- If gear shifting adjustments cannot be carried out, check the alignment of the dropout and check if the cable is lubricated or if the outer casing is too long or too short.
- Periodically clean the shifting unit and lubricate all moving parts (mechanism and pulleys).
- Note the installation direction of the pulleys. Depending on the model, the pulley has arrows on it to indicate the direction of rotation. Install the pulley so that the arrows are pointing counterclockwise when looking at the outer side of the shifting unit.
- If you hear abnormal noise as a result of excess play in a pulley, you should replace the pulley.

The actual product may differ from the illustration because this manual is intended mainly to explain the procedures for using the product.

LIST OF TOOLS TO BE USED

The following tools are needed for installation/removal, adjustment, and maintenance purposes.

Tool	
	2 mm hexagon wrench
	3 mm hexagon wrench
	4 mm hexagon wrench
	5 mm hexagon wrench
	Cross head screwdriver [#2]
	Hexalobular [#27]
	TL-CT12

INSTALLATION/REMOVAL

Installing the rear derailleur

TECH TIPS

- The rear derailleur will not gear shift properly if the derailleur hanger is not straight. Use TL-RD11 to check whether the derailleur hanger is straight or not.

1. Set the switch lever in the OFF position.

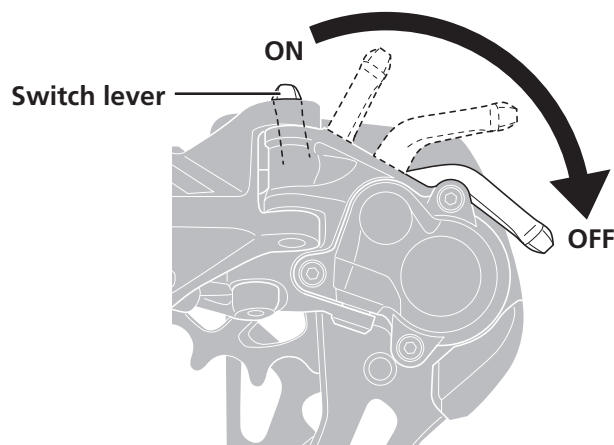

2. Tighten the rear derailleur fixing screw.

Be careful not to insert the rear derailleur fixing screw in the dropout at an angle. In addition, be sure to install the rear derailleur so that the stopper plate contacts the B-tension stop, with no gap in between.

Rear derailleur fixing screw

5 8 - 10 N·m

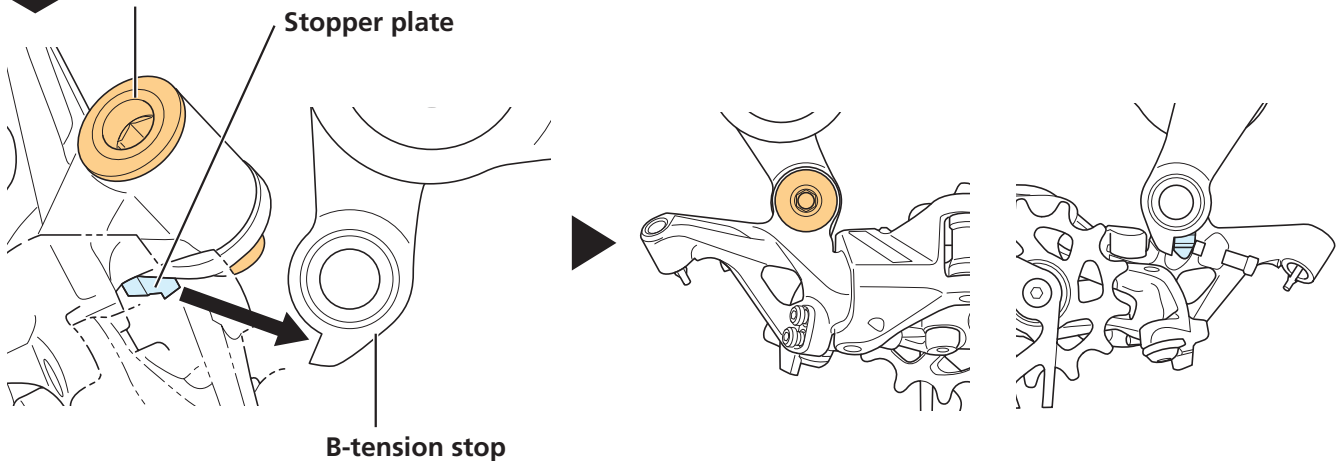

NOTICE

- Periodically check to make sure that there is no gap between the B-tension stop and the stopper plate. If there is a gap between these two parts, problems with gear shifting performance may occur.

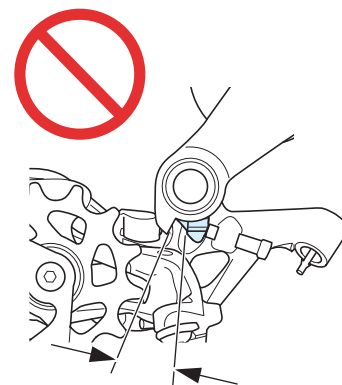

ADJUSTMENT

Adjusting the stroke on the high limit

1. Adjust by turning the high limit screw.

Adjust so that the center of the guide pulley is aligned with the outer line of smallest sprocket when viewed from the rear side.

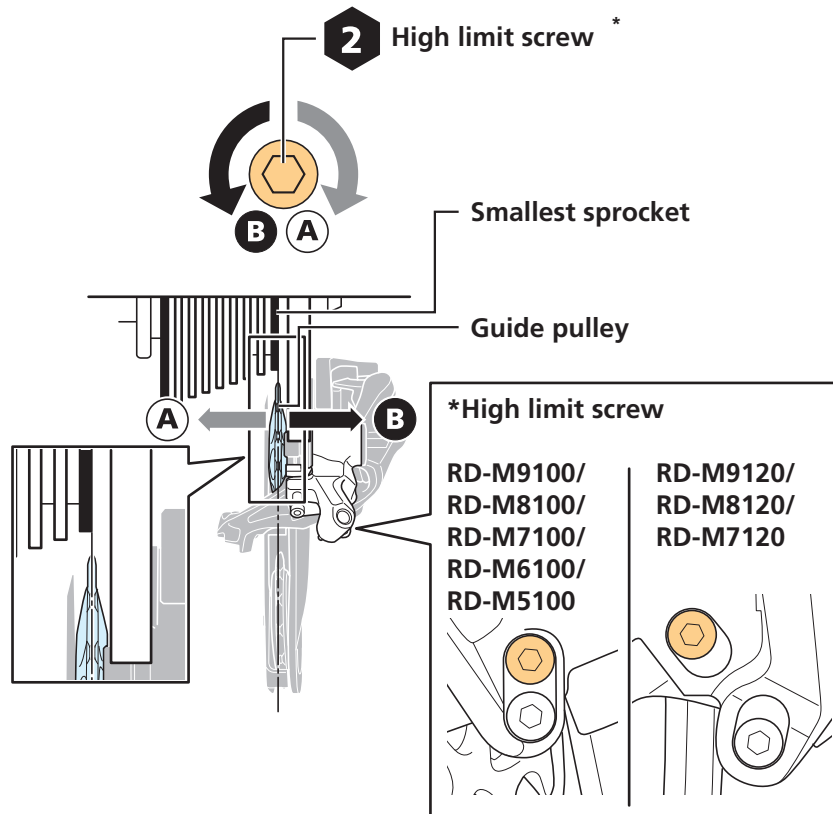

Installing the chain

Refer to the dealer's manual for the chain to find instructions on installing/removing the chain.

Checking the chain length

1. Mount the chain on the largest sprocket and the largest chainring.

In order to check the length at the rear of the cassette sprocket, join the two ends of the chain at the rear of the cassette as shown in the figure.

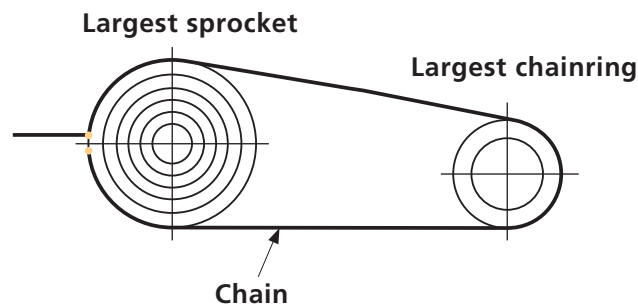

2. Check the length of the chain.

With the zero point of the chain established on the rear of the largest sprocket, the proper final chain length is determined by adding a certain amount of links to this resulting chain length. The amount of links is dependent on the type of bike. See the figure below.

Hardtail bikes

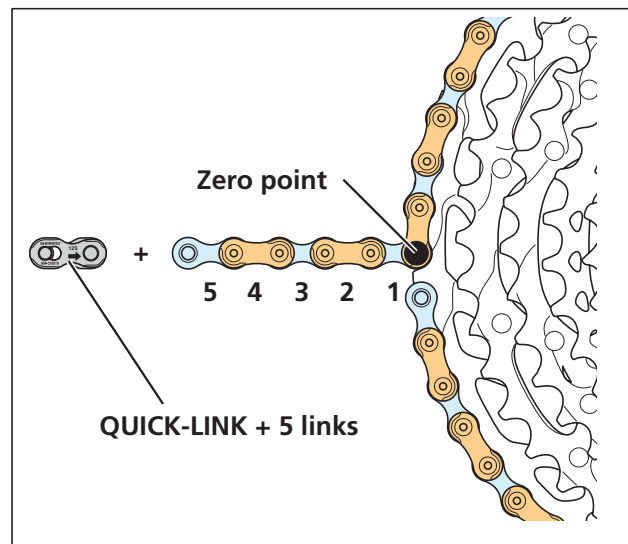
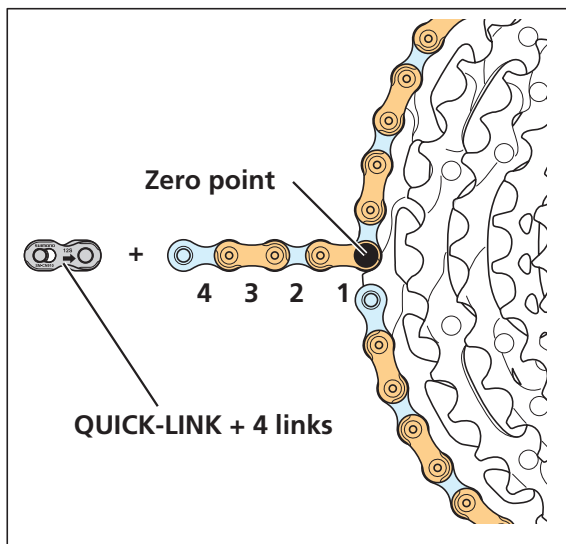

Full suspension bikes

* For full suspension bikes, check the length of the chain with the suspension in its fully extended position.

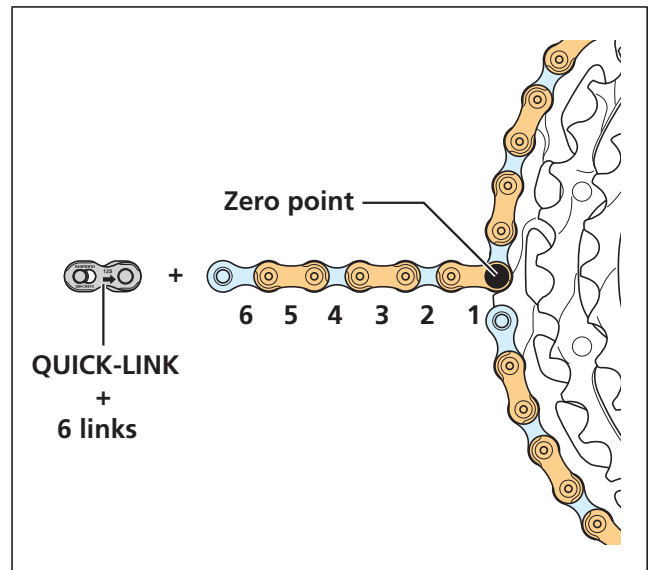
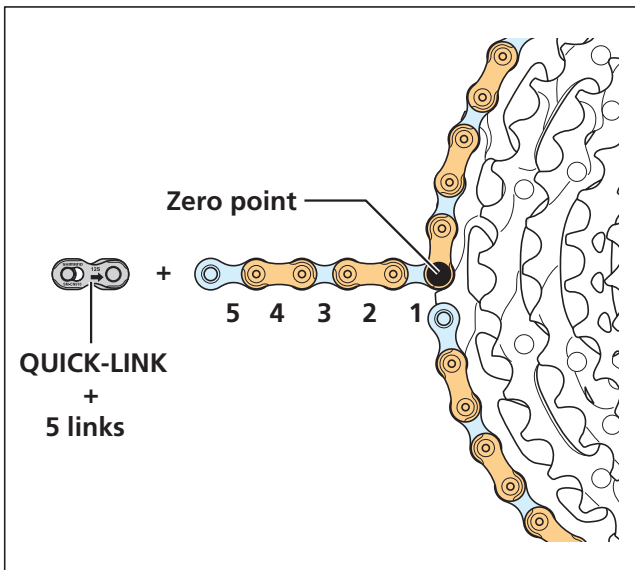

Bike type	Number of links added
Hardtail bikes	4 to 5 links + a QUICK-LINK
Full suspension bikes	5 to 6 links + a QUICK-LINK

NOTICE

- The rear derailleur plate assembly is equipped with a pin or plate that prevents chain derailment. When passing the chain through the rear derailleur, pass it through the main body of the rear derailleur from the side of the chain derailment prevention plate as shown in the figure.
- If the chain is not passed through the correct position, damage may be caused to the chain or the rear derailleur.

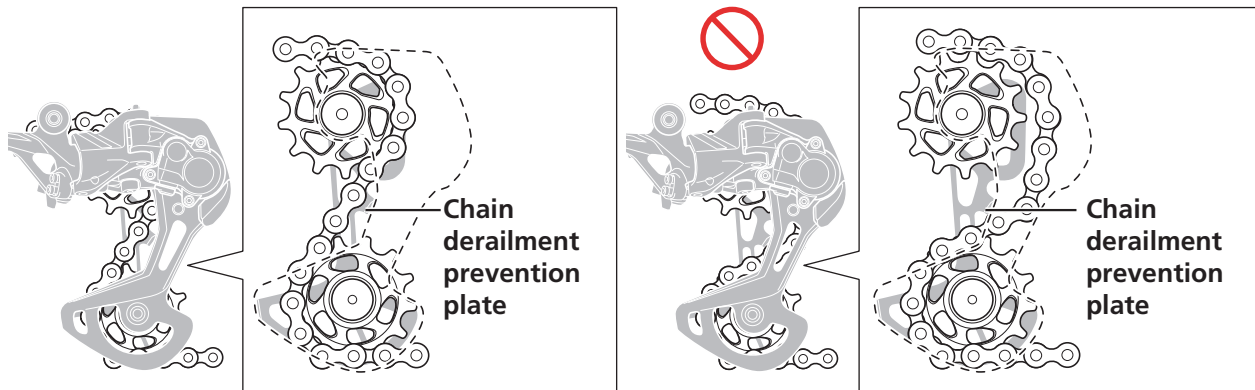

- For full suspension bikes, length [a] will vary according to the movement of the rear suspension. After shifting to the largest chainring and the largest sprocket, make sure that the chain length is not too short when dimension [a] is at its maximum extension. If the chain length is too short, drivetrain components may be damaged due to excessive load on the drivetrain.

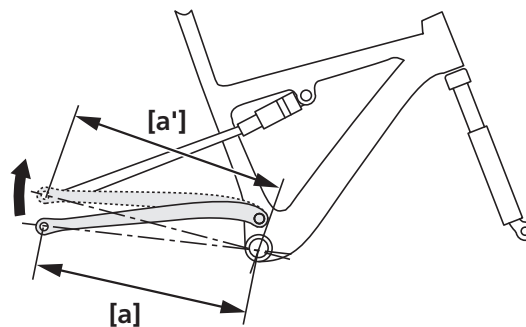

Connection and securing of the inner cable

Outer casing length

1. Loosen the B-screw to the position shown in the figure.

Make sure that the stopper plate touches the bracket body without leaving a gap.

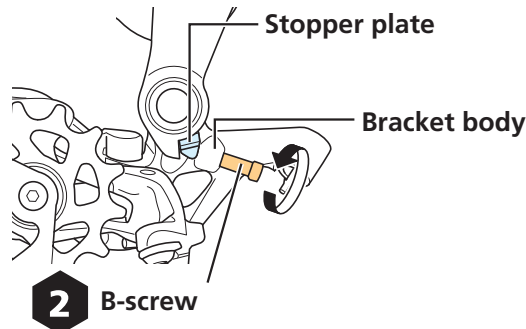

2. Determine the length of the outer casing.

Fit a sealed outer cap to the end of the outer casing. Align the end of the outer cap to the bottom edge of the outer casing holder on the rear derailleur.

Make sure to leave enough slack in the outer casing.

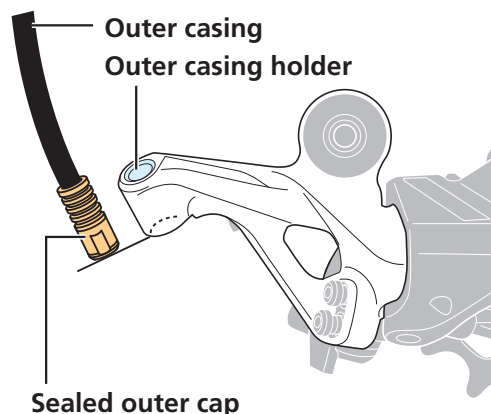

NOTICE

- The length of the outer casing may be insufficient as the suspension moves through its travel. Determine the appropriate length at the point in the suspension travel where the potential length of the outer casing is the greatest.

TECH TIPS

- If the motion of the rear derailleur is extreme, such as in bicycles with a rear suspension, replacing the sealed outer cap with the supplied aluminum type sealed outer cap is recommended.

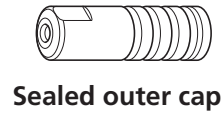

Sealed outer cap

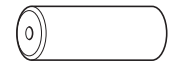
Sealed outer cap
(aluminum type)**3. Cut off any excess outer casing with the cable cutter.**

After cutting, return the outside of the outer casing to a perfect circle so that the inside of the hole has a uniform shape.

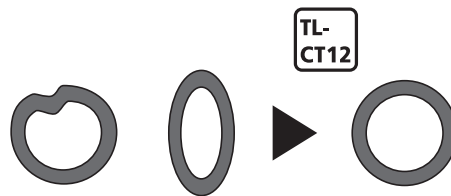
**4. Install the sealed outer cap to the end of the outer casing.**

Route the inner cable through the outer casing.

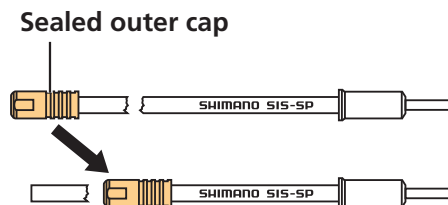

5. Install the sealed outer cap with tongue and rubber shield onto the outer casing stopper of the frame.

For bikes with full length outer casing, this step is not necessary.

Be careful not to bend the tongue.

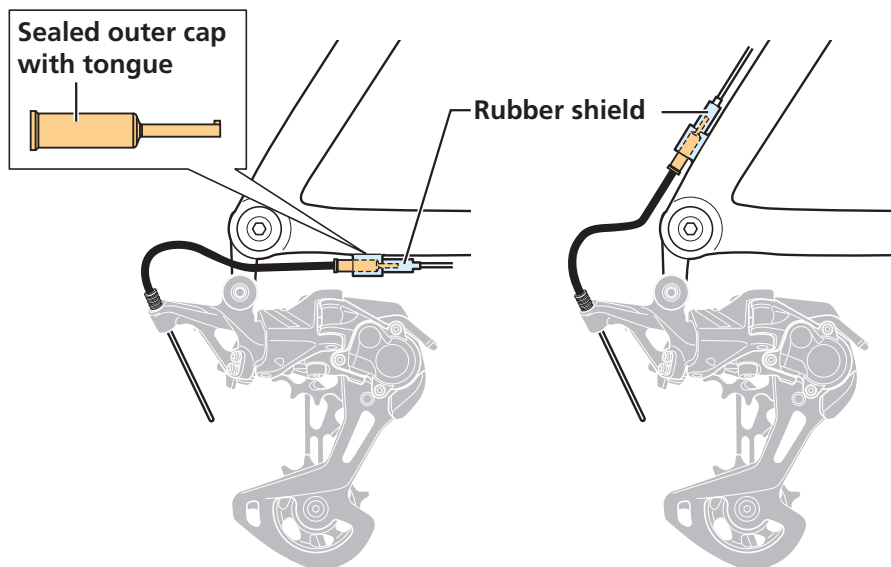

Connection and securing of the inner cable

1. Set the shifting lever in its initial position.

Operate the release lever 11 or more times for a 12-speed and 10 or more times for an 11-speed.

2. Secure the inner cable to the rear derailleur.

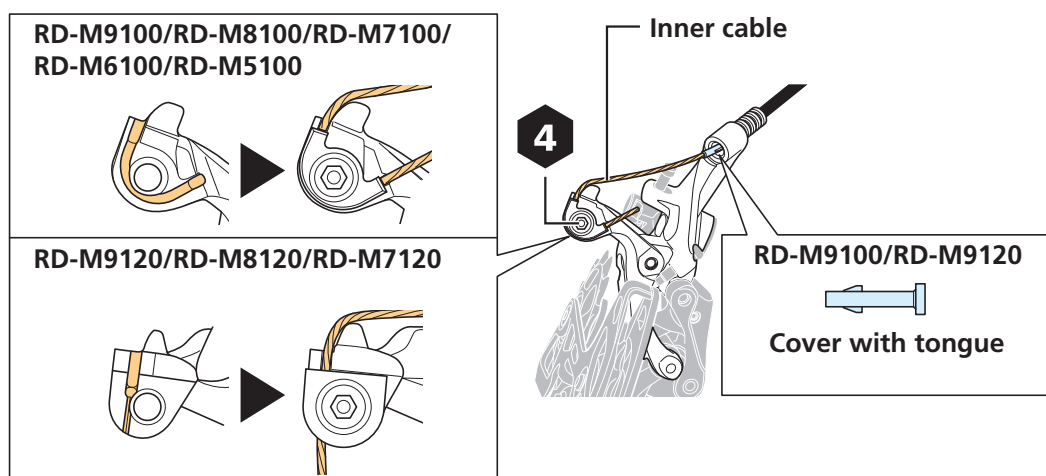

NOTICE

- For RD-M9100/RD-M9120, replacing the cover with tongue is recommended when replacing the inner cable.
- Cables with a polymer coating may develop a fuzzy appearance or texture through natural wear when used. However, if the cables are installed with care according to the procedures outlined in this manual, this is strictly cosmetic and performance will not be affected where the inner cables are housed by outer casing.

3. Remove the initial slack from the inner cable.

Hold the rear derailleur so that it won't move under load from the shift cable. Operate the shifting lever several times in order to tension the shift cable assembly and fully seat all the shift cable components.

4. Re-secure the inner cable to the rear derailleur.

While pulling the inner cable, be sure that it is secured along the groove.

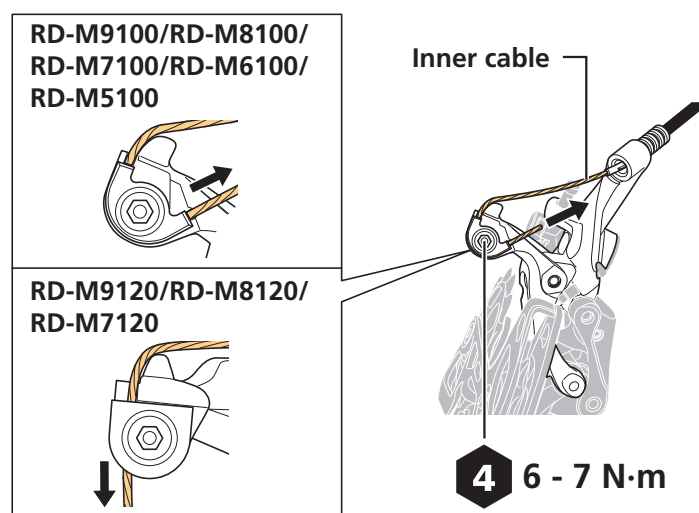

5. Cut the inner cable so that the protruding length is approximately 20 mm.

Install the inner end cap.

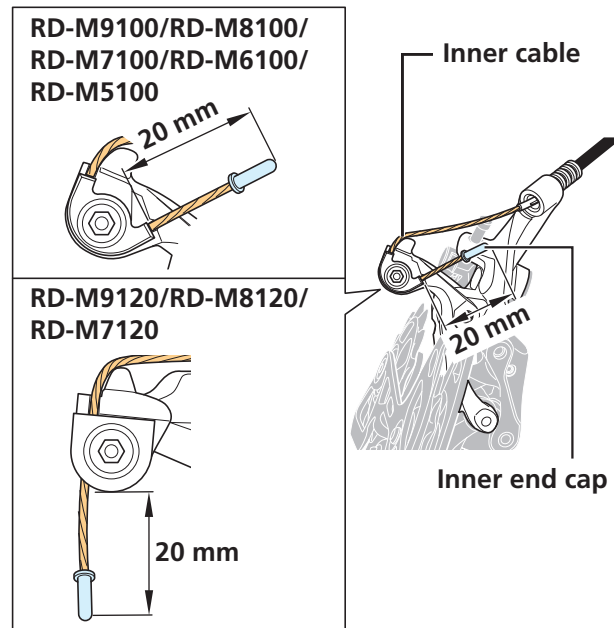

NOTICE

- Check that the inner cable does not interfere with the spokes of the wheel.
- Do not allow the wheel to turn while carrying out this step.

Adjusting the stroke on the low limit

1. Adjust by turning the low limit screw.

Adjust so that the center of the guide pulley is aligned with the center of the largest sprocket.

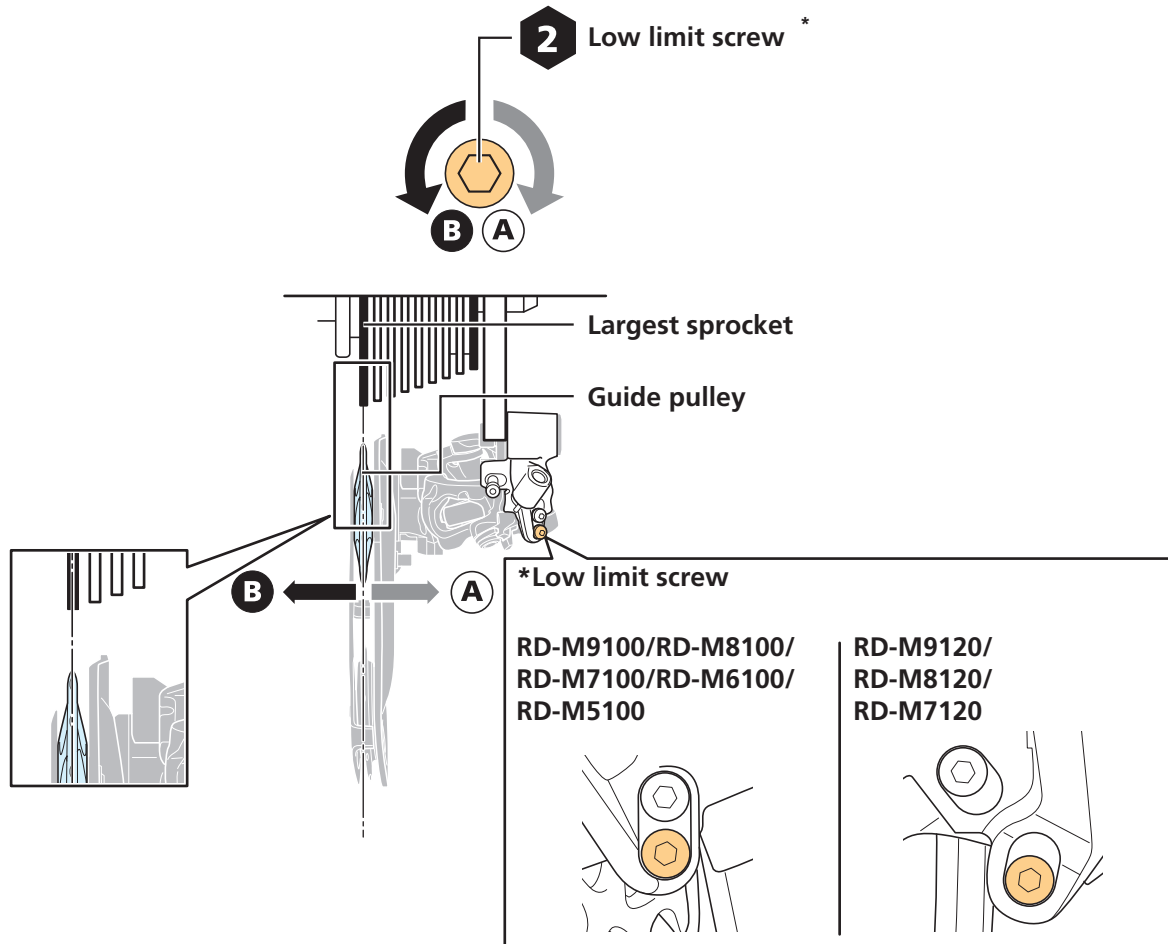

Adjusting the B-screw

1. Set the chain on the smallest chainring and the largest sprocket.

Turn the crank arm and shift the gears.

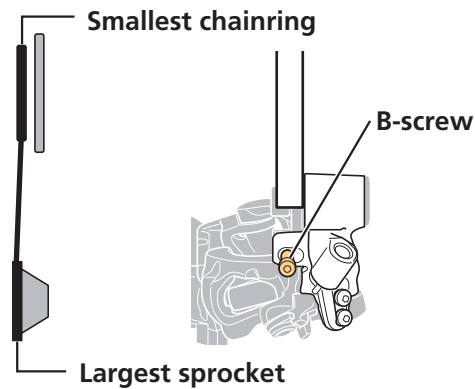

2. Adjust the B-screw.

Adjust it to one of the following settings based on the combination of products being used.

Rear derailleur	Cassette sprocket		
	12-speed, 10 - 45T	12-speed, 10 - 51T	11-speed, 11 - 51T
RD-M9100-GS	(A)	-	-
RD-M9100-SGS / RD-M8100-SGS / RD-M7100-SGS / RD-M6100-SGS	-	(A)	-
RD-M9120-SGS / RD-M8120-SGS / RD-M7120-SGS	(B) For a double chainring (C) For a single chainring	-	-
RD-M5100-SGS	-	-	(A)

(A) Align the line on the inner side of the outer plate with the tip of the highest tooth on the largest sprocket.

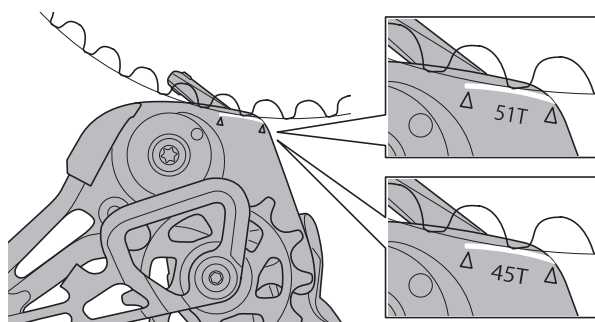

(B) Align the contour of the outer plate and the tip of the highest tooth on the largest sprocket between the arrows on the inner side of the outer plate.

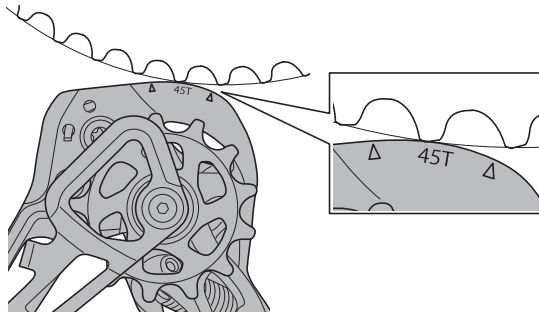

(C) Set the distance between the tip of the highest tooth on the largest sprocket and the center of the guide pulley as listed in the table.

Model	Sprocket	Distance
RD-M9120-SGS / RD-M8120-SGS / RD-M7120-SGS (For a single chainring)	12-speed, 10 - 45T	46 mm

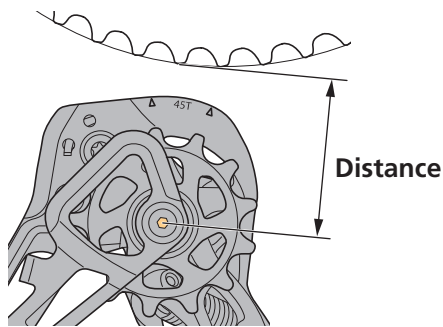

SIS adjustment

1. Set the switch lever in the OFF position.

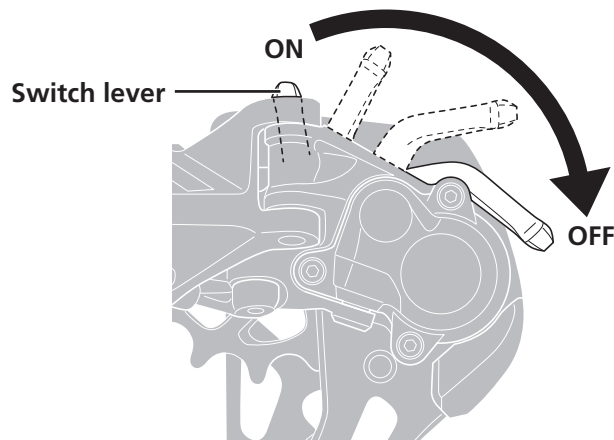

2. Operate the shifting lever several times to shift the chain to any gear that is five to seven steps from the largest sprocket.

For bicycles with double front chainrings, shift to the largest chainring.

NOTICE

- If the chain rubs against the larger adjacent sprocket and makes noise while turning the crank, turn the cable adjustment barrel clockwise until there is no noise.

3. Turn the cable adjustment barrel counter-clockwise while turning the crank until you start to hear the chain rub on the larger sprocket.

Cable adjustment barrel

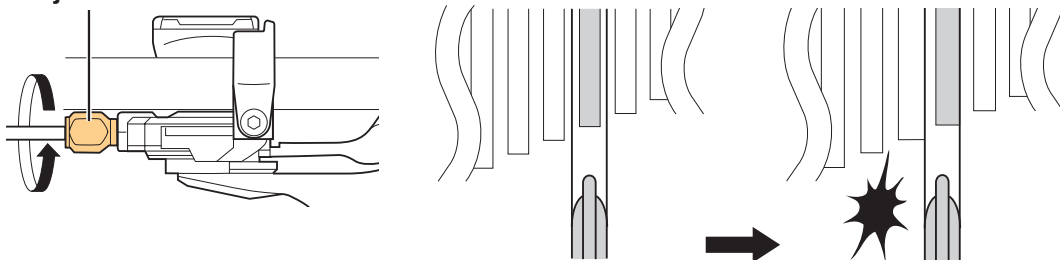

- 4.** The best setting is achieved when the cable adjustment barrel is turned five clicks in the clockwise direction.

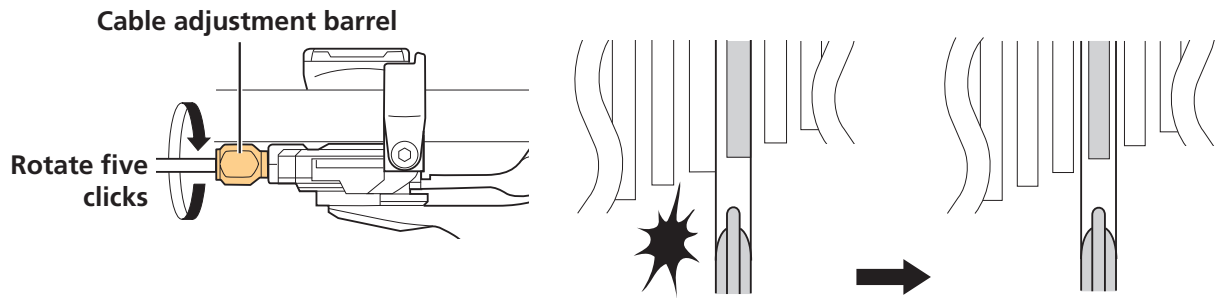

- 5.** Operate the shifting lever to change gears while turning the crank, and check that no noise occurs in any of the gear positions.

TECH TIPS

- The rear derailleur will not gear shift properly if the derailleur hanger is not straight. Use TL-RD11 to check whether the derailleur hanger is straight or not.

- 6.** Set the switch lever in the ON position and check that the gear shifting is smooth, consistent, and that there is no noise in any of the gear positions while riding the bicycle.

MAINTENANCE

Replacing the pulleys

1. Replace the guide pulley and tension pulley.

Check the arrow direction on the pulley when installing it. There may be no specified direction in which to install the pulley, depending on the model.

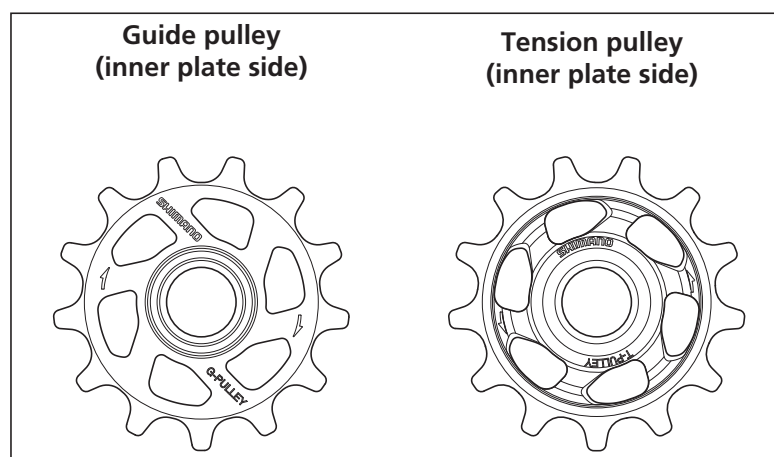
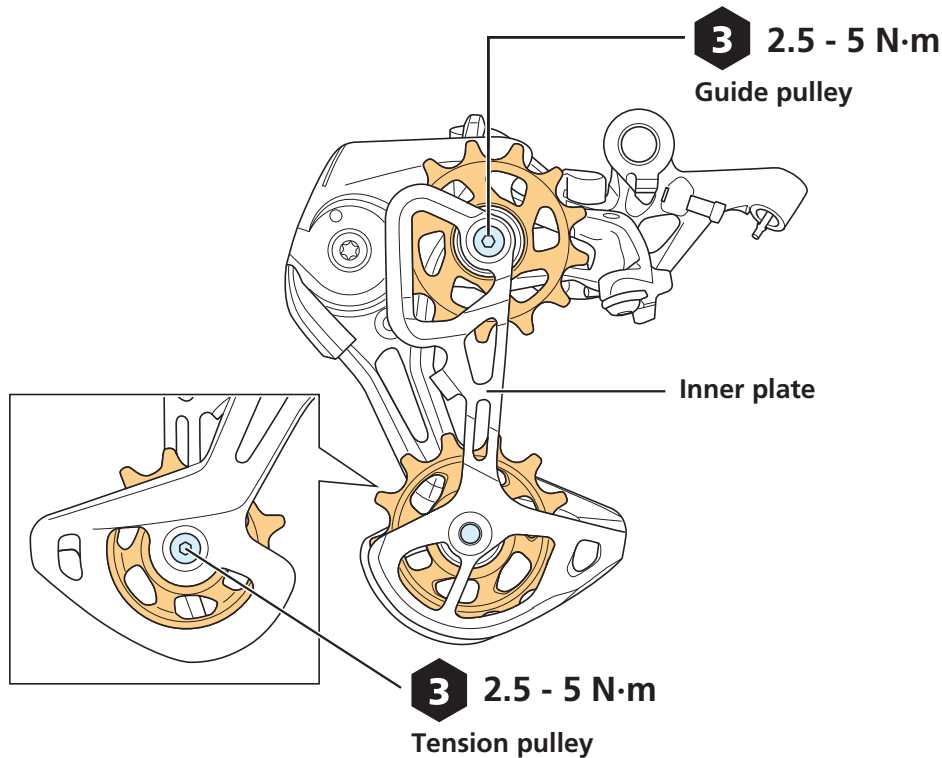

Replacing the B-axle

1. Push the B-axle from the inner side and use a tool such as a slotted screwdriver to widen and remove the C-ring.

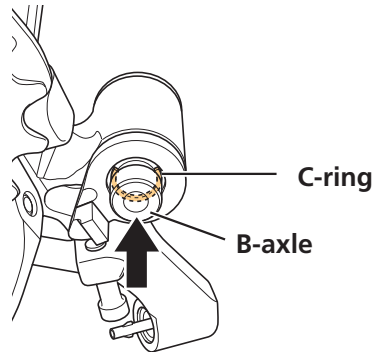

2. Push the threaded portion of the B-axle against the stopper plate and use the hexagon wrench to unthread the B-axle from the stopper plate.

Replace the B-axle with a new one and install it in the reverse order from the removal procedure.

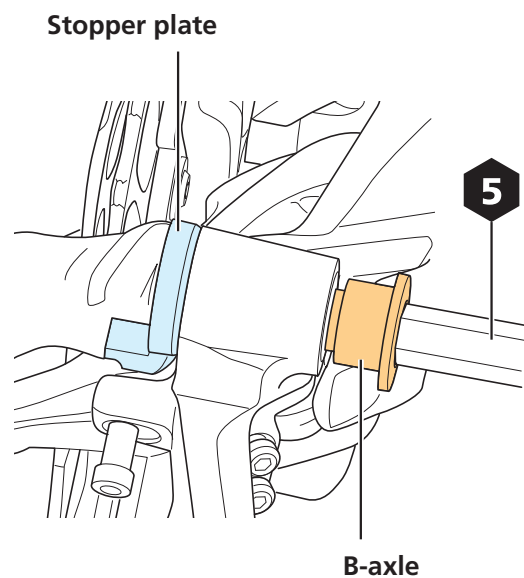

Replacing the bumper

There is no bumper on RD-M9120/RD-M8120/RD-M7120/RD-M6100/RD-M5100.

1. Remove the bumper so that it flips forward as shown in the figure.

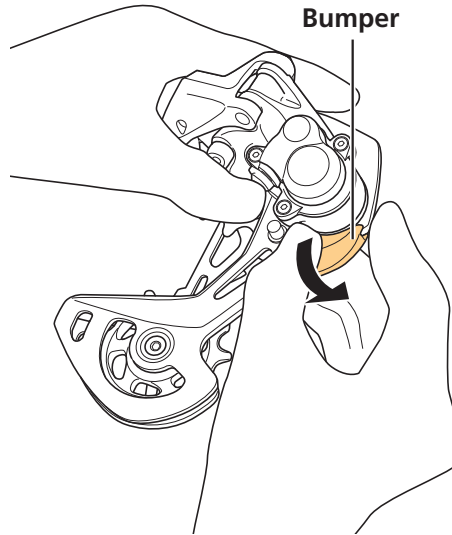

2. Install a new bumper by sliding it on from the side as shown in the figure.

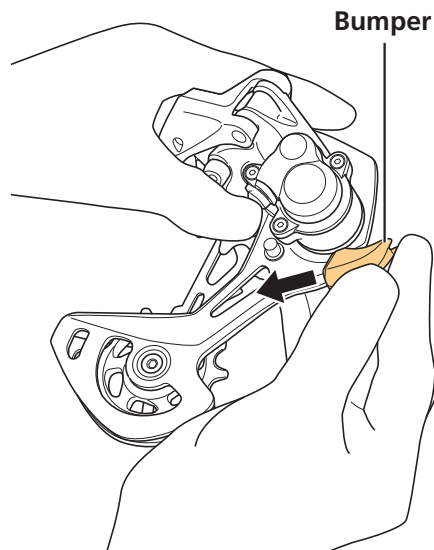

Applying grease to the chain stabilizer

If there is a noticeable change in friction in the chain stabilizer assembly, or if it starts to make noise, you may need to add grease to the chain stabilizer.

1. Set the switch lever in the OFF position.

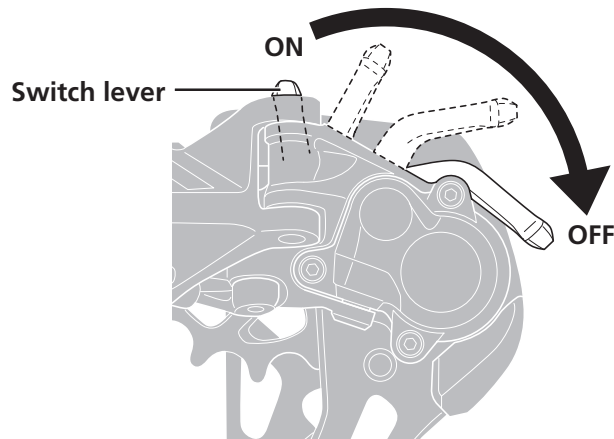

2. Remove the plate unit cover.

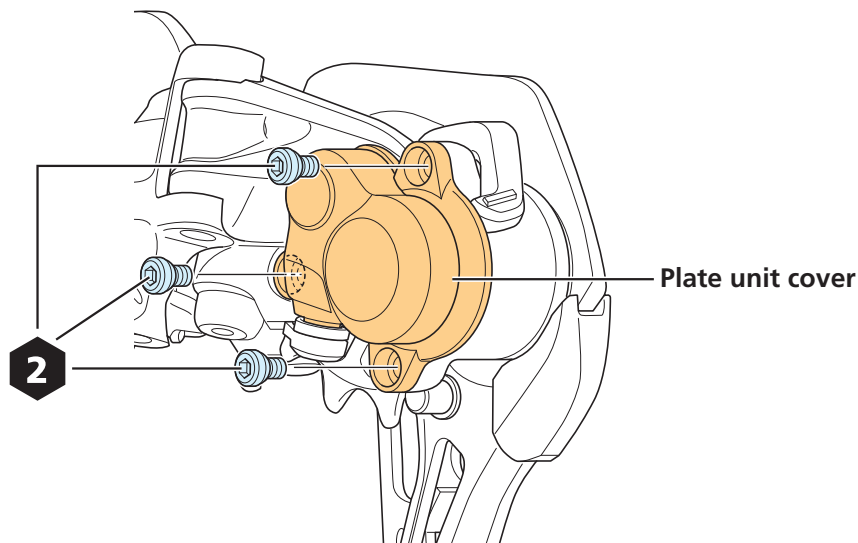

3. Remove the cam unit and the chain stabilizer.

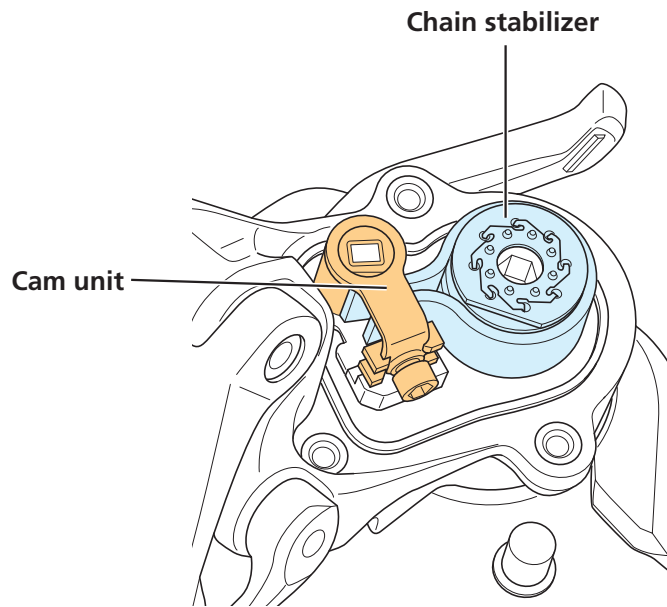

4. Apply the dedicated grease to the outer diameter of the outer portion of the roller clutch.

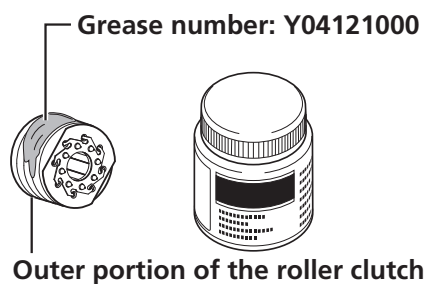

NOTICE

- Be careful not to get grease inside the roller clutch. If grease gets inside the roller clutch, it will cause the roller clutch to stick or slide and malfunction.

When assembling, reverse the procedure.

Adjusting friction

The level of friction can be adjusted as desired. Furthermore, the friction can also be adjusted when it changes during use.

Friction adjustment

1. Set the switch lever in the ON position.
2. Remove the plate unit rubber cap or plate unit cover as shown in the figure.

The plate unit rubber cap can be removed by hand.

RD-M9100/RD-M9120/
RD-M8100/RD-M8120

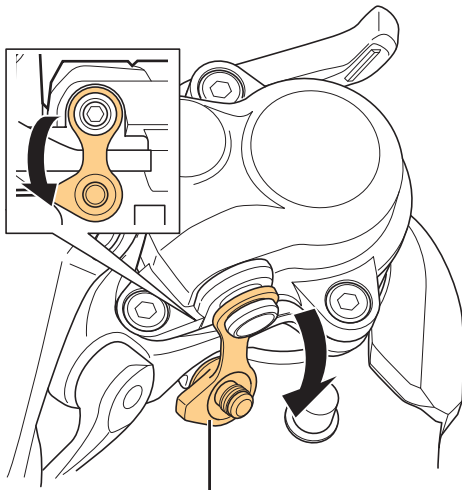

Plate unit rubber cap

RD-M7100/RD-M7120/
RD-M6100/RD-M5100

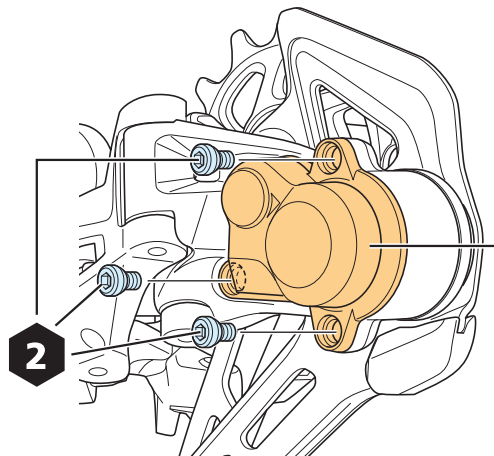
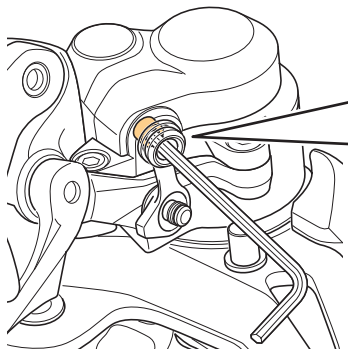

Plate unit cover

3. Turn the friction adjustment screw with a hexagon wrench to adjust the friction.

RD-M9100/RD-M9120/
RD-M8100/RD-M8120



RD-M7100/RD-M7120/RD-M6100/
RD-M5100

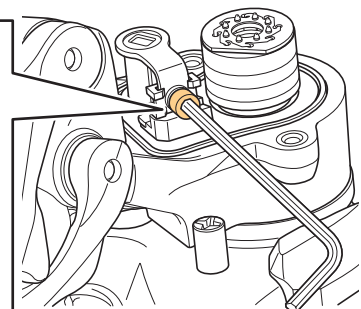
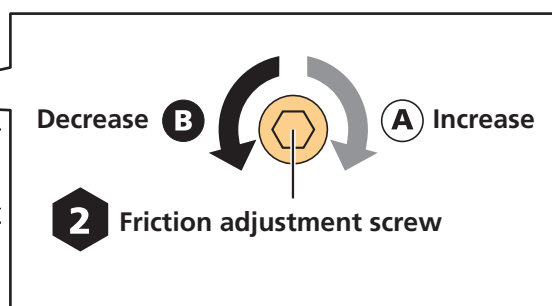

NOTICE

- Do not adjust the friction with a torque of 0.25 N·m or higher. Turning the screw excessively may cause damage.

4. Check the friction torque.

RD-M9100/RD-M8100/RD-M7100/RD-M6100/RD-M5100

Insert a hexalobular wrench into the outer plate and check the friction torque.

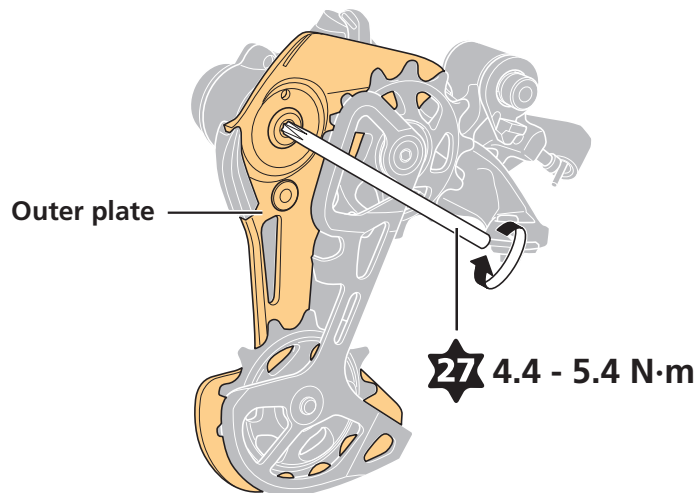

RD-M9120/RD-M8120/RD-M7120

(1) Remove the inner plate, guide pulley, and tension pulley.

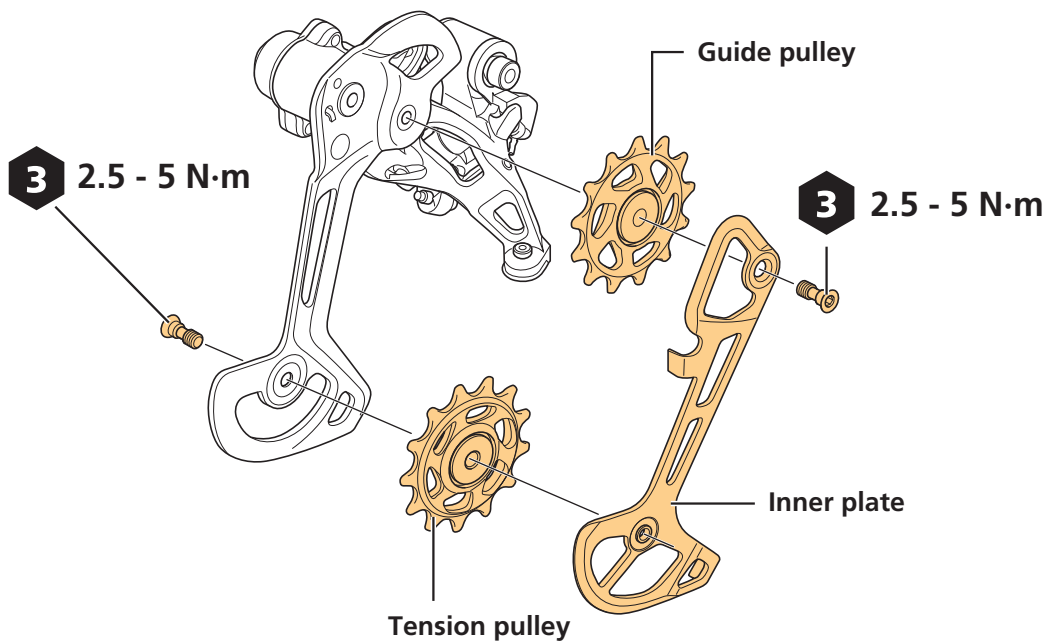

(2) Insert a hexalobular wrench into the outer plate and check the friction torque.

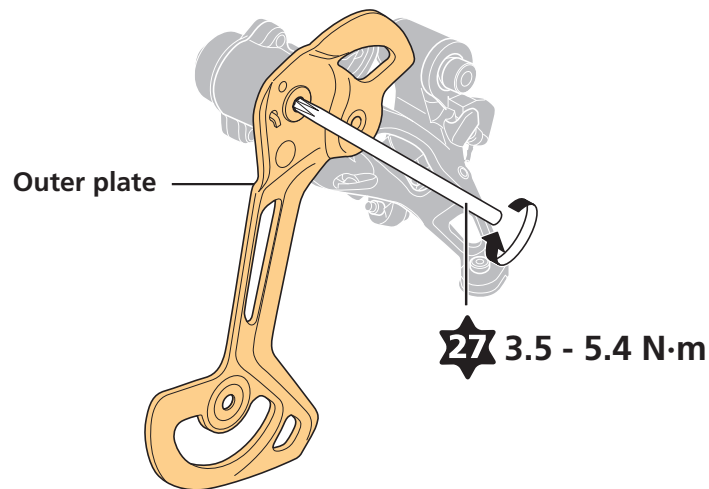

(3) Install the inner plate, guide pulley, and tension pulley.

Refer to “Replacing the pulleys” to install the inner plate, guide pulley, and tension pulley.

5. Install the plate unit rubber cap or plate unit cover as shown in the figure.

RD-M9100/RD-M9120/RD-M8100/RD-M8120

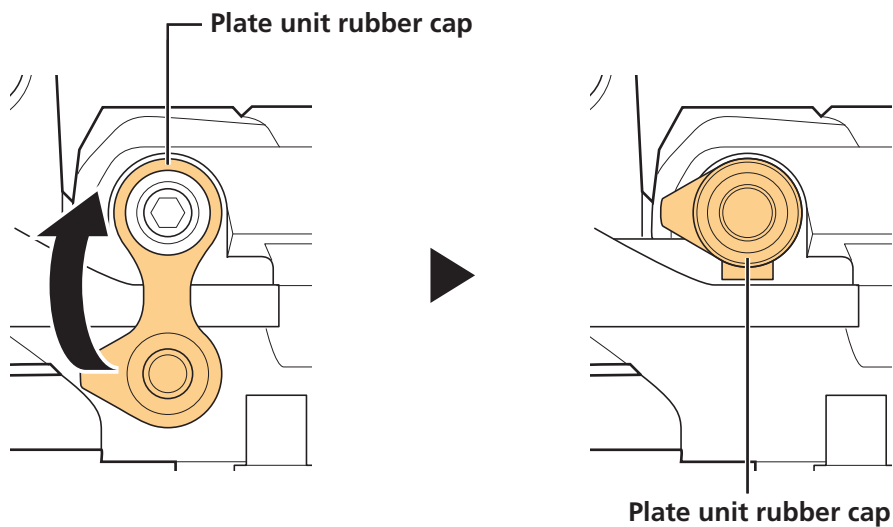

RD-M7100/RD-M7120/RD-M6100/RD-M5100

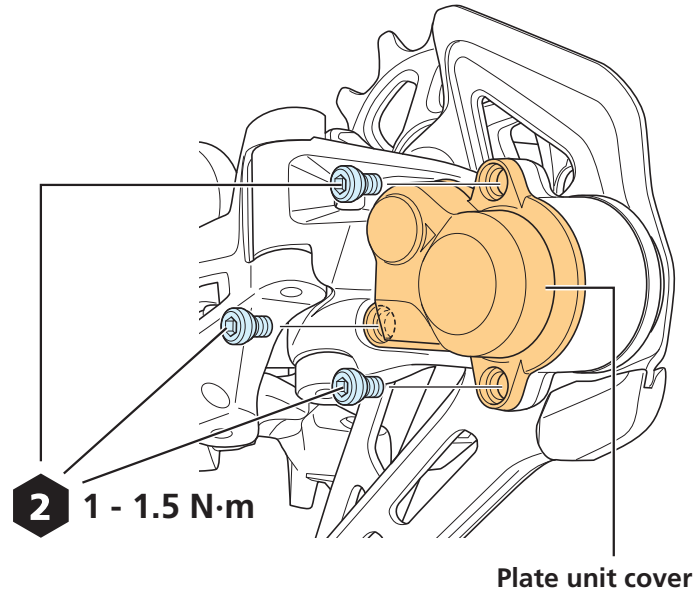

Replacing the plate, plate tension spring, and switch lever

Removal

1. Set the switch lever in the OFF position.

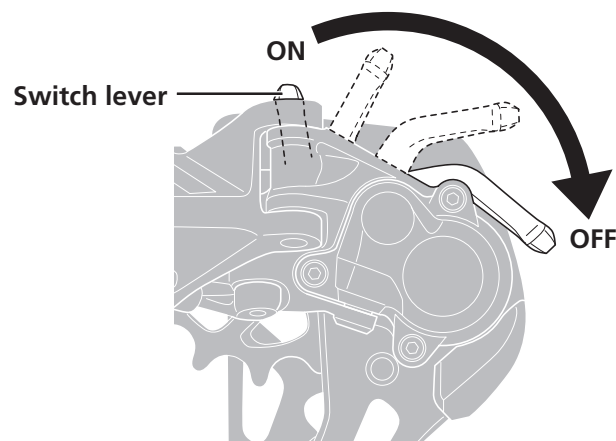

NOTICE

- If operating the switch lever while the plate unit cover is removed, hold the friction unit down with your finger so that it does not slide out.

2. Remove the plate stopper pin with a cross head screwdriver.



2 Plate stopper pin

3. Turn the plate to loosen the plate tension spring.

As shown in the figure, squeeze the outer casing holder and cable attachment portion together to move the link and turn the plate.

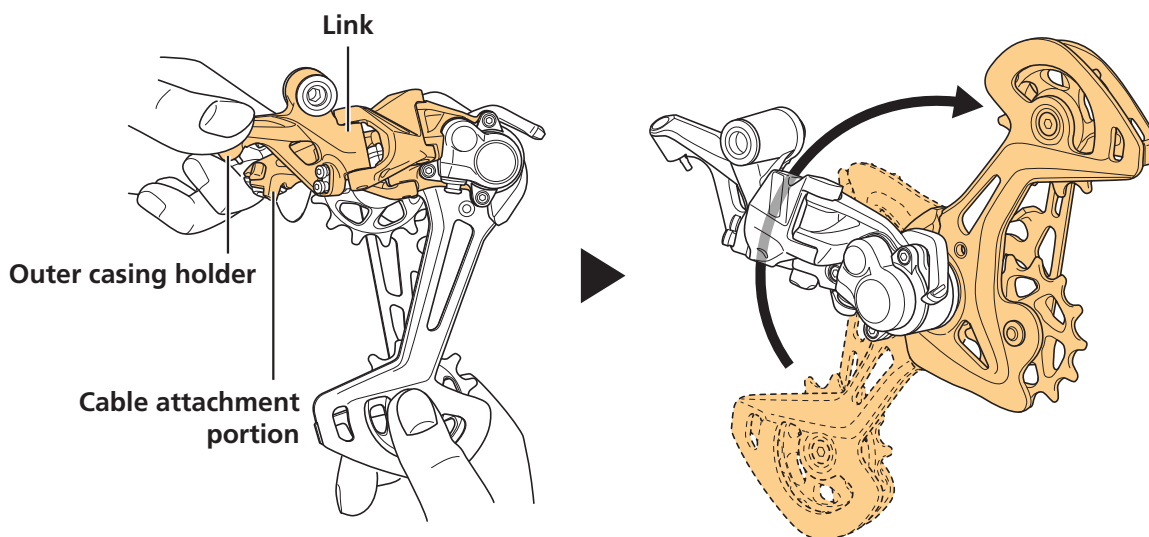

4. Remove the plate unit cover screws.

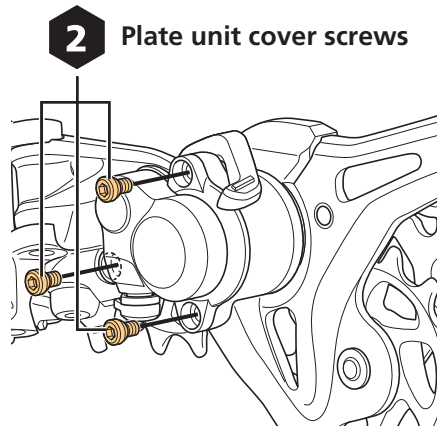

5. Remove the plate unit cover.

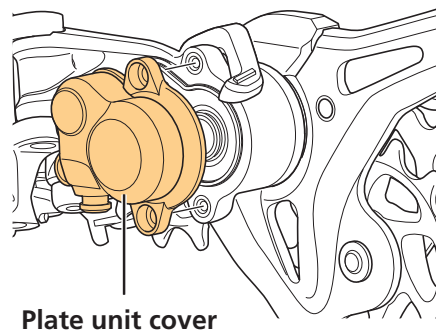

6. Remove the cam unit and the chain stabilizer.

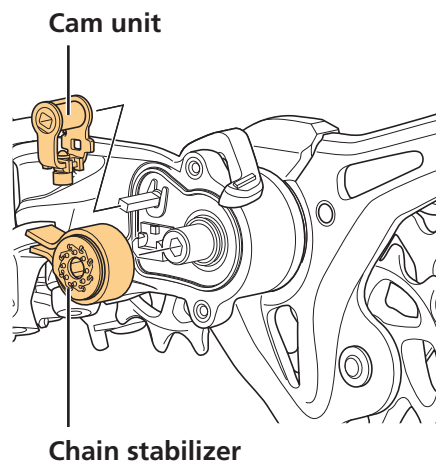

7. Remove the plate axle.

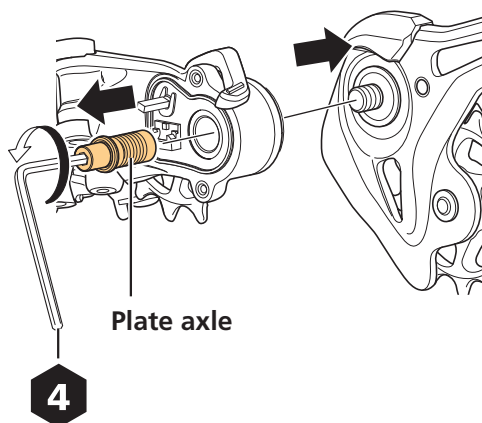

8. Remove the retaining clip and the switch lever.

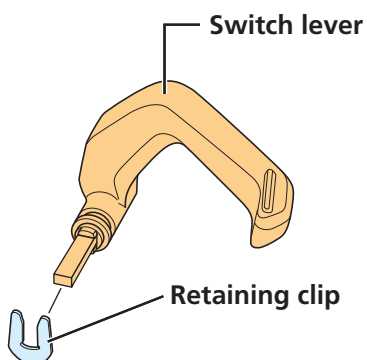
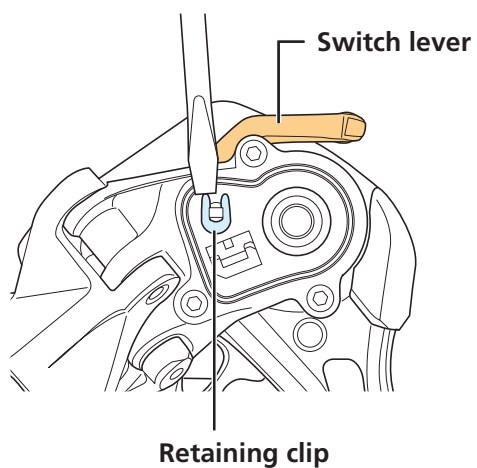

9. The unit can be disassembled as shown in the figure.

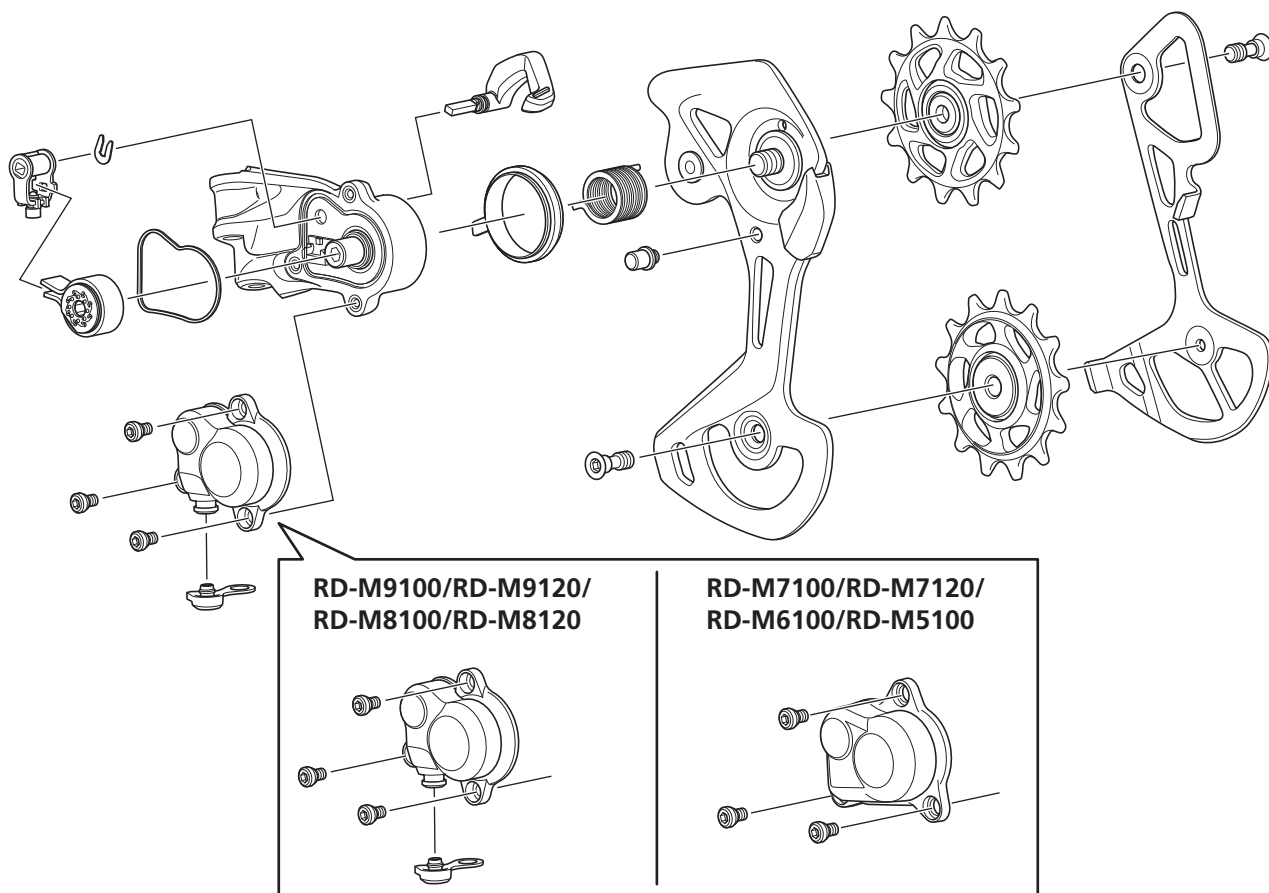

Installation

Perform the installation in the reverse order from the removal procedure.

1. Apply the dedicated grease to the plate axle.

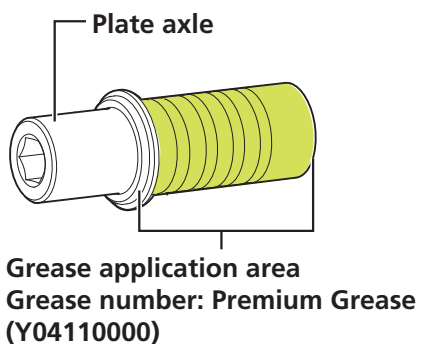

NOTICE

- Do not apply grease outside of the application area indicated above. If grease is applied here, it will get inside the outer portion of the roller clutch and friction will be lost due to slipping.

2. Insert the plate axle, and then fit the tip of the plate tension spring in the hole of the plate.

RD-M9100/RD-M8100/RD-M7100/
RD-M6100/RD-M5100

RD-M9120/RD-M8120/RD-M7120

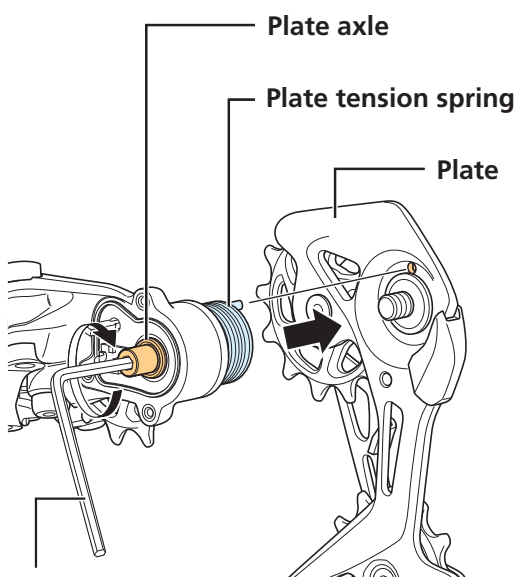

4 7.8 - 9.8 N·m

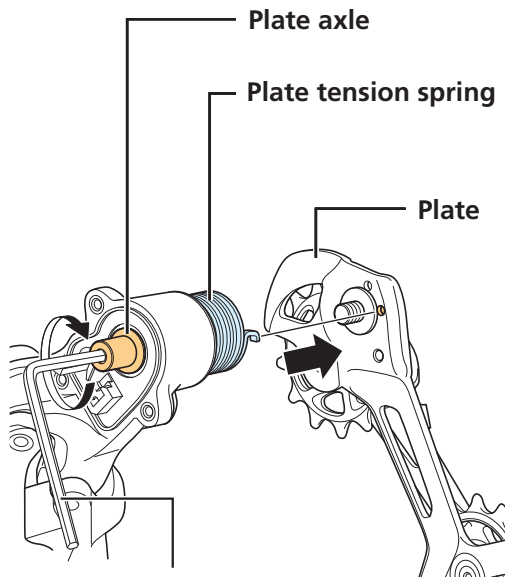

4 7.8 - 9.8 N·m

3. Install the switch lever and engage the retaining clip.

Set the switch lever in the OFF position.

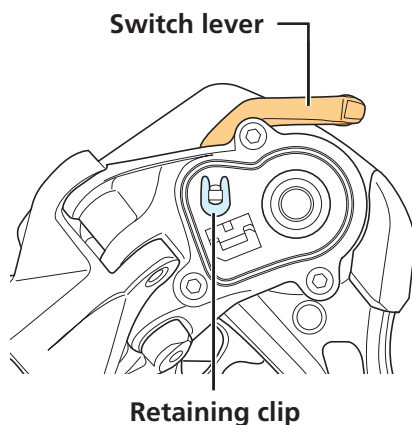

4. Set the chain stabilizer into the cam unit as shown in the figure.

Check that the cam lobe of the cam unit is in the position shown in the figure.

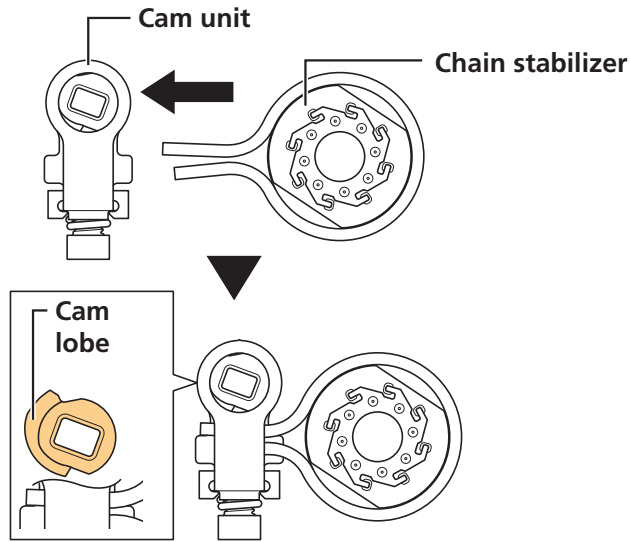

NOTICE

- Do not set it in the cam unit with the cam lobe positioned as shown in the figure.

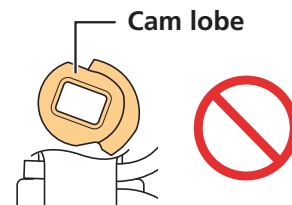

5. Align the holes of the cam unit and chain stabilizer with the protrusions on the plate unit, and then install.

Pay attention to the positioning of the cam lobe of the cam unit when installing.

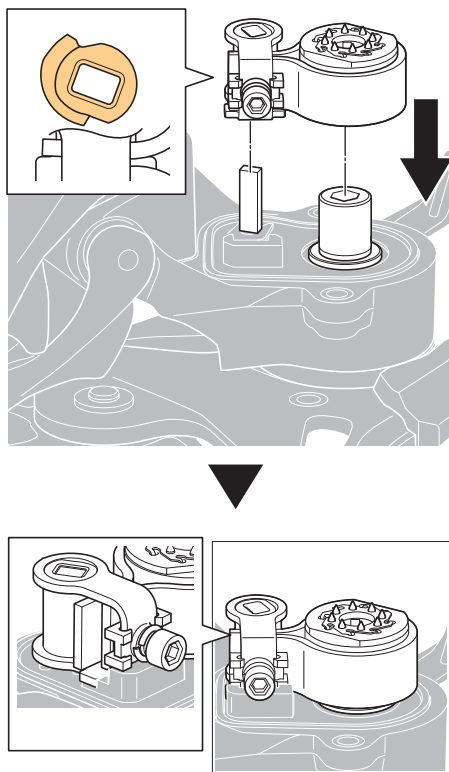

NOTICE

- Do not install the plate unit cover with the cam unit only partially connected to the base of the plate unit. Insufficient sealing may cause rust to form on the internal structure and the plate may become stuck.

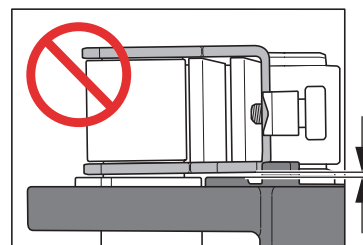
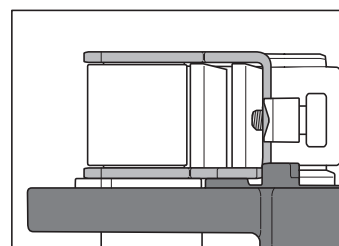

TECH TIPS

- When installing, it helps to move the plate while holding down the cam unit and chain stabilizer.
- If there is resistance when moving the switch lever to the ON position, the components are installed correctly. If there is no resistance, check the position of the cam lobe of the cam unit and then reinstall the components.

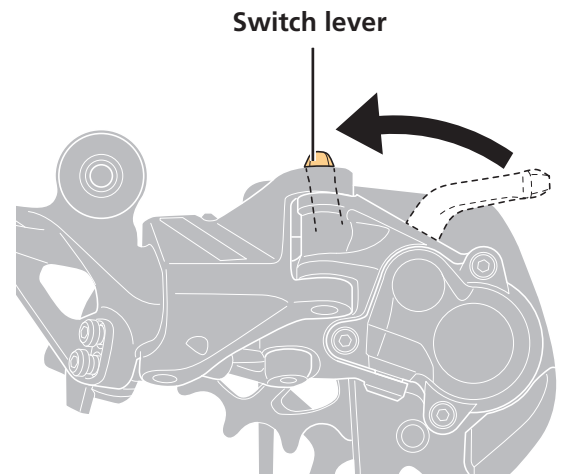
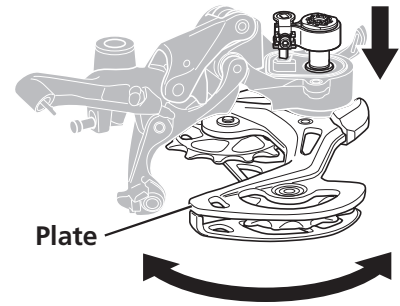

6. Apply the dedicated grease to the plate unit cover gasket and install.

Check that the plate unit cover gasket is installed along the groove in the plate unit.

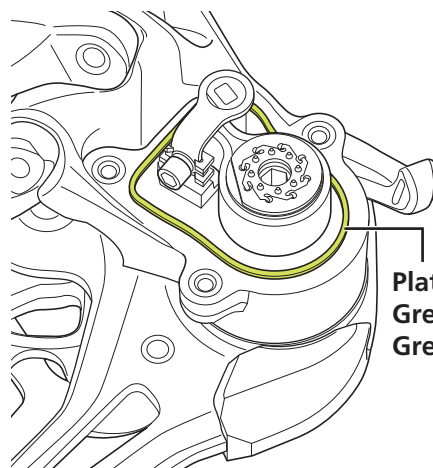

Plate unit cover gasket
Grease number: Premium
Grease (Y04110000)

7. Install the plate stopper pin.

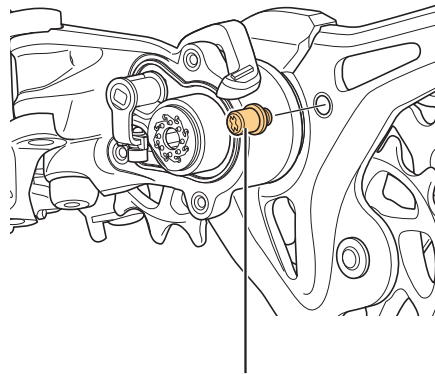
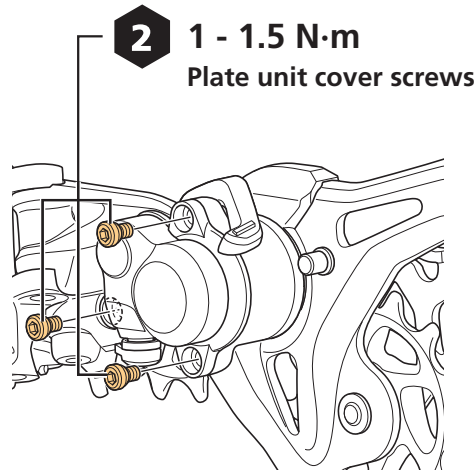

Plate stopper pin

2 1 N·m

8. Install the plate unit cover screws.



2 1 - 1.5 N·m

Plate unit cover screws

9. Check the friction, and adjust as necessary.

Refer to "Adjusting friction" for adjustment friction.

SHIMANO

SHIMANO NORTH AMERICA BICYCLE, INC.

One Holland, Irvine, California 92618, U.S.A. Phone: +1-949-951-5003

SHIMANO EUROPE B.V.

High Tech Campus 92, 5656 AG Eindhoven, The Netherlands Phone: +31-402-612222

SHIMANO INC.

3-77 Oimatsu-cho, Sakai-ku, Sakai City, Osaka 590-8577, Japan

Please note: specifications are subject to change for improvement without notice. (English)

© Jan. 2020 by SHIMANO INC. ITP