



SIDETRAK SOLO FREESTANDING 4K MONITORS

START GUIDE



240.580.8725 | customerservice@sidetrak.com

WELCOME



Congratulations on your purchase! We are confident that you will be satisfied with your new portable monitor. Our mission is to bring joy to people at work by offering the portability of a laptop with the productivity of working on two screens.

The benefits of a second screen will make your worklife easier!

WELCOME TO A MORE PRODUCTIVE YOU!

CONTENTS



- 1 Product Interface
- 2 What's In the Box
- 3-5 Operating Instructions
- 6 Menu Settings
- 7 Frequently Asked Questions
- 8 Technical Specifications
- 9 Contact Us

PRODUCT INTERFACE



SideTrak Solo 4K Portable Monitor

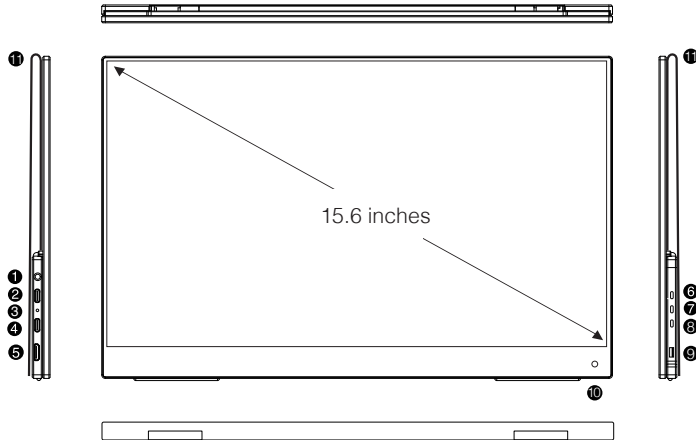

❶		3.5mm Headphones Input	External audio connector, headset
❷		Type-C USB Input	USB-C type power only
❸		LED Indicator	LED Light Indicator
❹		Type-C USB Input	USB-C type power and graphics connector
❺		HDMI Input	HDMI type power connector
❻		Volume / Menu Button	Increase (+) Volume / Upward selection in the menu
❼		On/ Off & Menu Button	Power on and off / Menu Button
❽		Volume / Menu Button	Decrease (-) Volume / Downward selection in the menu and return
❾		USB Input	USB input for external keyboard, mouse, U disk, etc.
❿		Remote Sensor	Receives signal from a remote controller
⓫		Protective Case/ Kickstand	Screen protector that doubles as a kickstand

WHAT'S IN THE BOX



Protective Case/
Kickstand



Monitor Screen



USB-C Cable



HDMI Cable



USB-A to USB-C
Cable























OPERATING INSTRUCTIONS



Watch the installation video here

1. Plug In

If your laptop has a USB-C port, connect one end of the USB-C to USB-C cable to the laptop and the other end to the monitor. Some laptops may not provide enough power to the monitor. Check the USB-C port on your laptop for the symbols shown in the table below. If you have one of the green checked symbols, then your USB-C port will provide data and enough power to the monitor. Note, MacBook ports are compatible even if there are no symbols next to it.

							
							
		All Apple laptops are compatible					

If the monitor won't turn on, connect the USB-A to USB-C cable along with the HDMI cable.

OPERATING INSTRUCTIONS



If your laptop does not have a USB-C port, connect one end of the USB-A to USB-C cable to the laptop and the other end to the monitor. Then also connect the HDMI cable.



If you are connecting to other devices, be sure to connect to an external power supply first by using the secondary USB-C port, then connect the HDMI cable to ensure a smooth transition of signal.

Monitor must be plugged in to power on.

2. Turn On

Press and hold the On/Off button for 3 seconds to power on your monitor.

3. Using Your Kickstand

Flip the protective cover over to the back of the monitor and bend the lower half of the protective cover to a 45 degree angle in order to use the protective cover as your monitor's kickstand.



OPERATING INSTRUCTIONS



4. Adjust Settings

To bring up the main menu press the power button once. When inside the menu use the “+” and “-” buttons to highlight the desired option, and press the power button once to select the highlighted option. Once the option is highlighted, use “+” and “-” buttons to adjust the values. Press and hold “-” button to return to the previous menu.

You can adjust the volume and back-light without bringing up the main menu by pressing the “+” and “-” buttons to adjust volume. Press and hold “+” and “-” buttons to adjust the back-light.

To prevent any damage to the monitor, please turn off and unplug the monitor when left unattended for long periods of time.



MENU SETTINGS

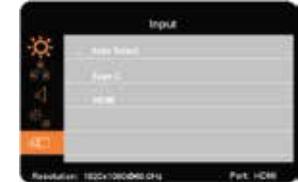
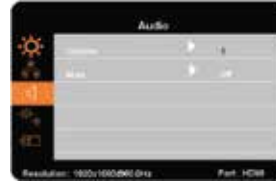
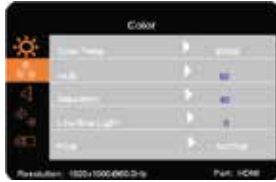

Brightness: Adjust from 0-10
Contrast: Adjust between 1-100
Eco: Choose between Standard, game, movie, photo, and vivid
DCR (Dynamic Contrast): turn on or off
Sharpness: Adjust between 0-4

Color temp: Change between 9300K, 6500K, and SRGB
Hue & Saturation: Adjust between 0-100
Low blue light: Adjust between 0-10
PCM: Change between Native, SRGB, and ADOBE

Volume: Adjust between 0-10
Mute: Turn sound on or off

Language: Change language
Display rotate: Change screen between landscape and portrait
HDR (High Dynamic Range): Change between off, auto, 2084.
Reset: Reset all settings
Battery: See battery power

Change input between auto, type-c, and HDMI



Menu settings are the same for both touch and non-touch monitors. However, the menu look different on each model. This is what the menu for the touchscreen model will look like.



Q: Is my laptop compatible with SideTrak Solo 4K?

A: Check the ports on your laptop. If you have a USB-C port with any of the symbols shown on page 3, then your laptop is compatible and you will only need to use one cord. If you don't have a compatible USB-C port, then you will need to plug in the HDMI cord and the USB-C to USB-A cord. If your laptop doesn't have an HDMI port, you may need to purchase an additional adapter, a hub, or a dongle.

Q: My monitor won't power on

A:

- If you are not using a USB-C to USB-C cord, then make sure your monitor is connected properly to your laptop with both the HDMI cord and the USB-A to USB-C cord.
- Try using a different port on your laptop or device. You can also try using a different cord.
- Make sure you have turned the monitor on by pressing the power button for three (3) seconds.
- Make sure the correct input source is selected through the input source menu.

Q: Why do I have to plug in two cords if I don't have a USB-C port on my laptop?

A: The USB-C to USB-C cord is strong enough to communicate power and graphics through one cord. If you can't use the USB-C to USB-C cord you will have to use the HDMI to HDMI cord along with the USB-A to USB-C cord so that it can communicate power through one cord and graphics on the other.

Q: How do I adjust brightness?

A: Press the power button once to bring up the main menu. Move up or down with the "+" and "-" buttons to find the brightness option. Select the brightness option by pressing on the power button. Once option has been selected, use "+" to increase brightness or "-" to decrease brightness.

Q: The touch feature will not work while connected with an HDMI cable

A: If you are using the HDMI cable, you will also need to use the USB-C cable in order for the touch function to work. Touchscreen capabilities do not work with mobile phones and might not work on some

TECHNICAL SPECIFICATIONS



SideTrak Solo 4K Portable Monitor

	Size	15.6 inch
	Model Name	STFR4K15BL / STFR4KTC15BL
	PPI	282.42
LCD Panel	Display size	15.6" LED-Backlight
	Brightness (Typical)	320-340cd/m2
	NTSC	45%
	Contrast (Typical)	1000:1
	Active Area (mm)	104.136 square inch
	Pixel Pitch (mm)	0.09(H) x 0.09(V)
	Resolution (H x V)	3840 x 2160
	Aspect Ratio	16:9
	Response Time (Typical)	25ms
	View Angles LR, UD(CR>10)	H 178° / V 178°
	Panel Surface	G+FF glass / Hard Coating
	Display Colors	16.7M
Refresh Rate	60Hz	
Interface	Input 1	TYPE-C x 2 (USB-C)
	Input 2	HDMI x 1

Output Terminal	Earphone	3.5mm Earphone x 1
	Speaker (Typical)	1W*2
Power	Consumption (Typical)	Typical 6W, Max 13W
	Power Mode Light	Power on: RED (LED)
Physical	Dimensions (W*D*H)	355 x 224 x 9.6mm
	Net Weight	760g
	Gross Weight	1.912KG
Controls	Front Control	Standard
	On Screen Display	Standard OSD format
	Color	9300,6500, User Mode
	Preset Mode	Standard, TXT, Movie, Game FPS, RTS



If you have any questions, we are here to help!

240.580.8725

customerservice@sidetrak.com

<https://sidetrak.com>

Follow us!

Stay updated on product launches, news, and tips.



@sidetrak.monitor



@sidetrakmonitor



facebook.com/sidetrakmonitor