



FA-250EX FLAMEPROOF MARINE LANTERN

The FA-250EX Zone 1 Lantern utilizes all the features of a standard FA-250 marine lantern with the addition of a flame-proof glass dome internal fixture to house either lamps, xenon flash tube, lampchangers, transformers or DC-DC converters in various combinations to meet the signaling performance requirements. The FA-250EX lantern system offers several advantages for offshore platform applications.

Features

- Variety of non-hazardous certified internals can be used due to the nature of the flameproof, IP-67 enclosure approval
- M20 or M25 quad cable entries remove the need for additional junction boxes
- Lens cover and the cast-aluminum base are the most durable and longest life system in use
- Smooth acrylic lens cover, the FA-250EX lantern eliminates the buildup of fillets of moisture, dust, salt spray, raindrops and other contaminants on the internal Fresnel lens prisms
- When fitted with an APCL-Series FLASHCHANGER®, the FA-250EX lantern becomes the most versatile product on the market
- Configured as a 10-mile, Morse U light, the lantern will accept an input voltage of 12, 18, 24 volts and, with an internally mounted DC-DC converter, 130VDC and operate a 12 volt, 2000 hour 35 watt tungsten halogen lamp
- Low maximum surface temperature of the fixture during operation; the 10-mile lantern has a maximum of 100°C (T5) at Tamb of 40°C where competing units are 200°C (T3)
- FA-250EX932: APCL-10 Six-place FLASHCHANGER® up to 150 watts
- FA-250EX952: APCL-5 Six-place FLASHCHANGER® up to 60 watts



SPECIFICATIONS

Height:	683mm (26 7/8")
Diameter:	359mm (14 1/8")
Weight:	20 kg (44 lbs.)
Input Voltage:	12, 18 or 24 Volts; 120-240 VAC 50-60 Hz Available
Power Consumption:	6 to 35 Watts
Available Colors:	White, Red, Green, Amber
Lens Type:	Tempered Toughened Glass; 250 mm 360° Visibility Acrylic Fresnel Lens; Smooth Lens Cover
Visibility:	360° Omnidirectional
Monitor and Control:	Optional
Synchronization:	Hard wire (Optional)
Lantern Housing:	Marine Epoxy Coated Cast LM-6 Aluminum Base
Operating Temperature:	-40°C to +55°C
Ingress Rating:	IP-67
Certificates:	

EC-Type Examination Certificate

Certificate No.: Intertek ITS10ATEX17118X

Coding: II 2 G Ex d IIB T4/5/6

Certificate No.: IECEx ITS 10.0040X

Coding: Ex d IIB T4/5/6 Tamb -20°C/-40°C to +40°C/+55°C Gb
(Dependent on Model)

Certificate No.: NCC 17.0083 X (INMETRO – Brazilian Market)

Coding: Ex d IIB T6...T4 Gb

Epsilon IP Certificate Number: 04TEST1386

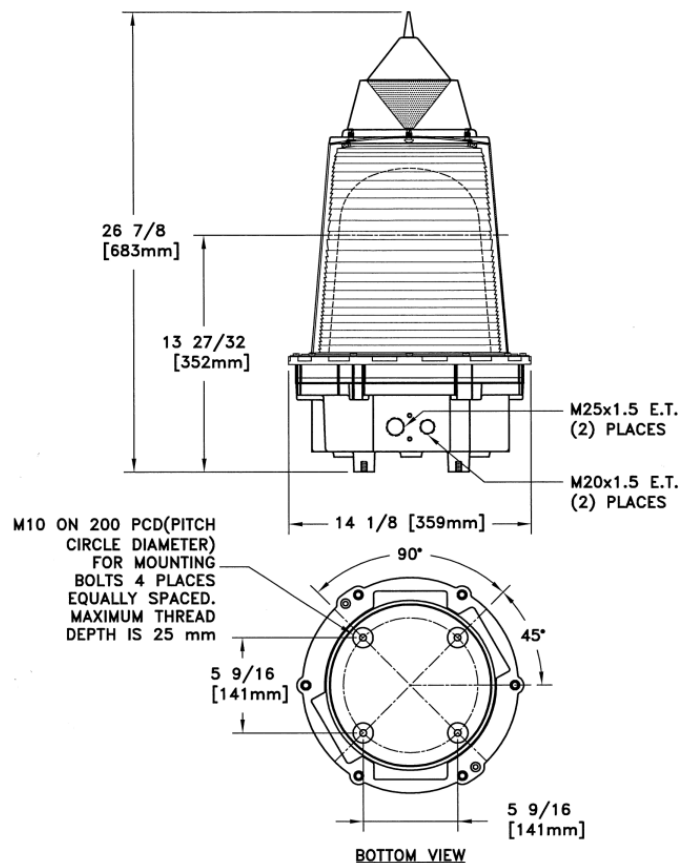

ADDITIONAL INFORMATION

APPLICATIONS/TEMPERATURE RATING

LAMP	CANDELA	APPLICATION	AMBIENT TEMP -20 to +40°C	AMBIENT TEMP -20 to +55°C
12V 35W	1950	IALA 10-MILE	T-5	T-4
12V 6W	36	SUBSIDIARY 3-MILE RED	T-5	T-4

Colored lens filter factors--red (0.30), green (0.32) and yellow (0.58).
Standard unit rated to -20°C; -40°C version at additional expense