

## EDS309...

Portable equipment for insulation fault location for unearthed and earthed systems (IT and TN systems) to be used in conjunction with or without an equipment for insulation fault location



## EDS309...

**Portable insulation fault location system for unearthed and earthed systems (IT and TN systems) to be used in conjunction with or without an insulation fault location system**



EDS309...

### Device features

- Portable insulation fault location systems for IT systems AC 0...790 V, 42...460 Hz/ DC 0...960 V or de-energised systems
- Residual current measurement in TN/TT systems
- Use in main and control circuits, photovoltaic systems
- Measuring clamps 20/52 mm (115 mm optional)
- Robust aluminium case, convenient to carry
- Locating current injectors PGH18... with variable locating current 1...25 mA
- Integrated locating voltage for de-energised systems (PGH186)

### Insulation fault locator EDS195PM

- Backlit LC display, 3 x 16 characters
- Measuring clamps 20/52 mm included in the scope of delivery
- Accumulator (delivered with a power supply unit)
- Response value insulation fault location 2...10 mA for main circuits
- Response value insulation fault location 0.2...1 mA for control circuits
- Response value residual current measurement 10 mA...10 A
- Selectable operating mode insulation fault location/residual current measurement

### Approvals



### Product description

The EDS309... is a portable insulation fault location system for localising insulation faults in unearthed systems (IT systems). All essential components are housed in a robust aluminium case which is convenient to carry.

### Application

IT systems **without** a permanently installed insulation fault location system

- **EDS3090PG**  
for main circuits up to AC 20...575 V 42...460 Hz, DC 20...504 V with AGE185 up to AC 500...790 V 42...460 Hz, DC 400...960 V
- **EDS3091PG**  
for control circuits up to AC 20...265 V 42...460 Hz, DC 20...308 V
- **EDS3092PG**  
for main circuits in conjunction with PGH185 up to AC 20...575 V 42...460 Hz, DC 20...504 V with AGE185 up to AC 500...790 V 42...460 Hz, DC 400...960 V  
for control circuits in conjunction with PGH183 up to AC 20...265 V 42...460 Hz, DC 20...308 V
- **EDS3096PG**  
for main circuits in IT systems with all poles disconnected up to AC 0...575 V 42...460 Hz, DC 0...504 V
- **EDS3096PV**  
for photovoltaic systems with PGH186 up to 20...575 V 42...460 Hz, DC 20...504 V with AGE185 up to AC 500...790 V 42...460 Hz, DC 400...960 V

IT systems **with** a permanently installed insulation fault location system

- **EDS3090**  
for main circuits with a permanently installed insulation fault location system with EDS460/490
- **EDS3091**  
for control circuits with a permanently installed insulation fault location system with EDS460/491

### Function

#### Locating current injector PGH18...

The PGH18... generates the relevant locating current signal. The locating current generated in this manner depends on the value of the insulation fault that is present and the system voltage.

- Depending on the switch position, the PGH185 or PGH186 limit the locating current is to a maximum of 25 mA respectively 10 mA.
- The PGH183 limits the locating current to a maximum of 2.5 mA or 1 mA respectively.

In de-energised IT systems or in IT systems with a system voltage of < 50 V, the PGH186 drives the locating current generated by an integrated voltage source (DC 50 V). In IT systems with a system voltage of > 50 V, the system voltage itself drives the locating current.

#### Insulation fault locator EDS195PM

The insulation fault locator EDS195PM provides the following measuring functions:

- Insulation fault location  $I_{\Delta L}$  (EDS mode) for use in IT AC or DC systems. The response value is determined by the sensitivity of the EDS195PM insulation fault locator. In DC, AC and 3AC IT systems, this is an arithmetic average value that can be set according to an arithmetic average value. System interferences and excessively high system leakage capacitances may have a negative influence on the accuracy
  - within the portable EDS309...insulation fault location system or
  - within a permanently installed insulation fault location system in conjunction with EDS15.../46.../49...
- Residual current measurement  $I_{\Delta n}$  (RCM mode) for use in TN or TT AC systems. The response range for the alarm message is 10 mA...10 A.

**Displays**

The LC display indicates the measured residual current, the type of the connected measuring clamp resp. measuring current transformer, the accumulator capacity, the activation of the alarm memory, the activation of the buzzer, and the set nominal frequency.

**Standards**

The portable insulation fault location systems have been designed in accordance with the following standards: DIN EN 61557-8 (VDE 0413-8), EN 61557-8, IEC 61557-8, IEC 61326-2-4, DIN EN 60664-1 (VDE 0110-1), DIN EN 60664-3, DIN EN 61557-9, VDE 0413-9, IEC 61557-9, ASTM F1669M-96 (2007), ASTM F1207M-96 (2007)

**Note:** Electrical interferences during operation may result in false tripping and indication errors.

**Application example**

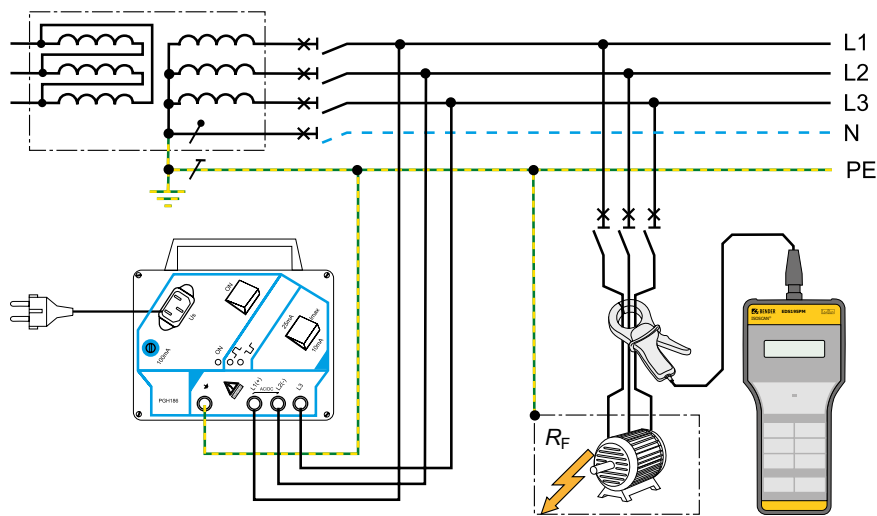

Equipment for insulation fault location EDS3096PG in de-energised systems (IT systems) (Note: TN-S system with all poles disconnected)

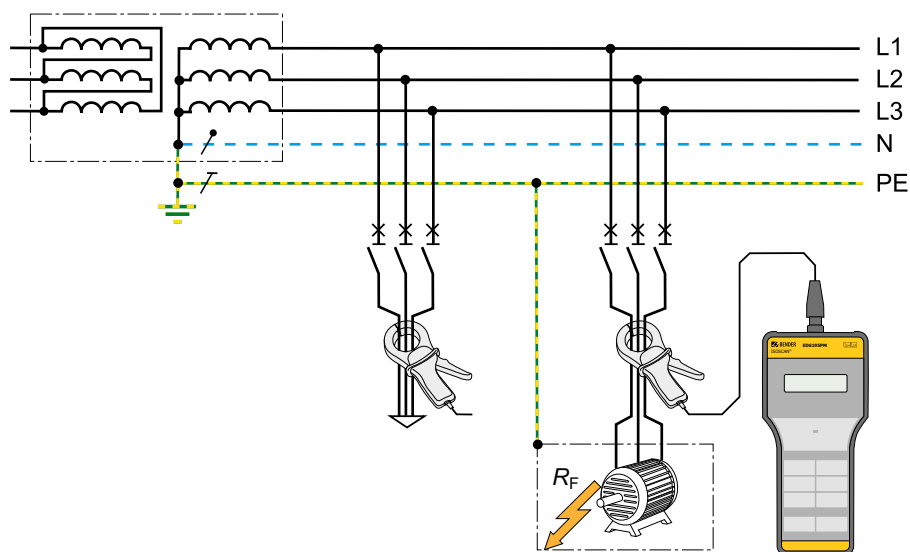

Residual current measurement with EDS309... in earthed systems (TN-S systems)

**Application example**

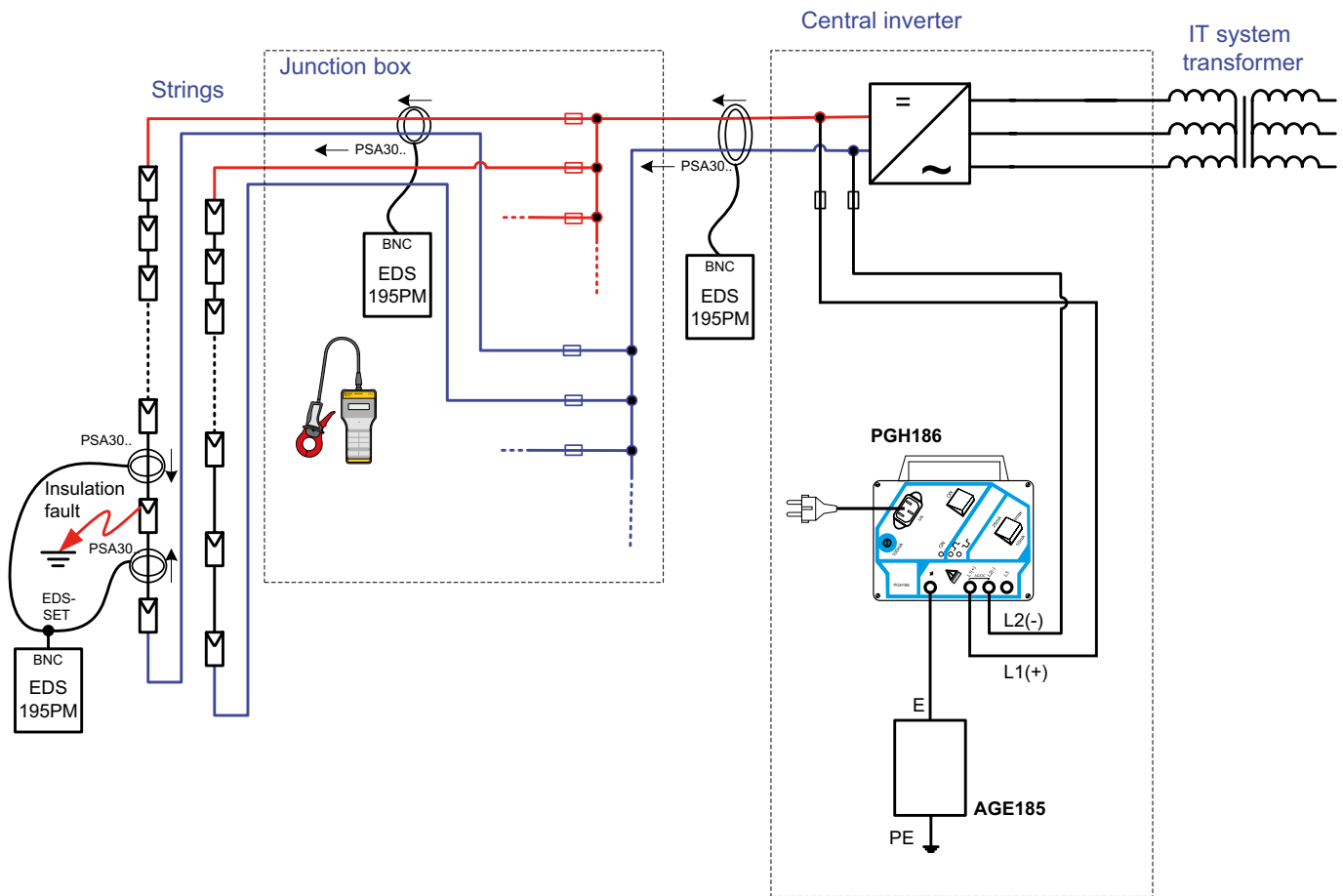

**Insulation fault location system EDS3096PV in unearthed photovoltaic systems (IT systems)**

**Application example**

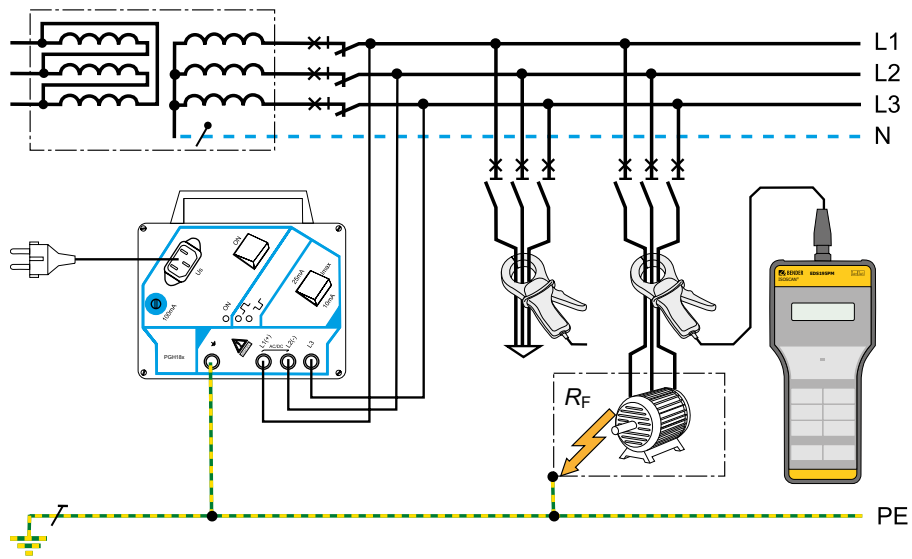

Equipment for insulation fault location EDS3090/3091PG for use in unearthed systems (IT systems) without a permanently installed equipment for insulation fault location

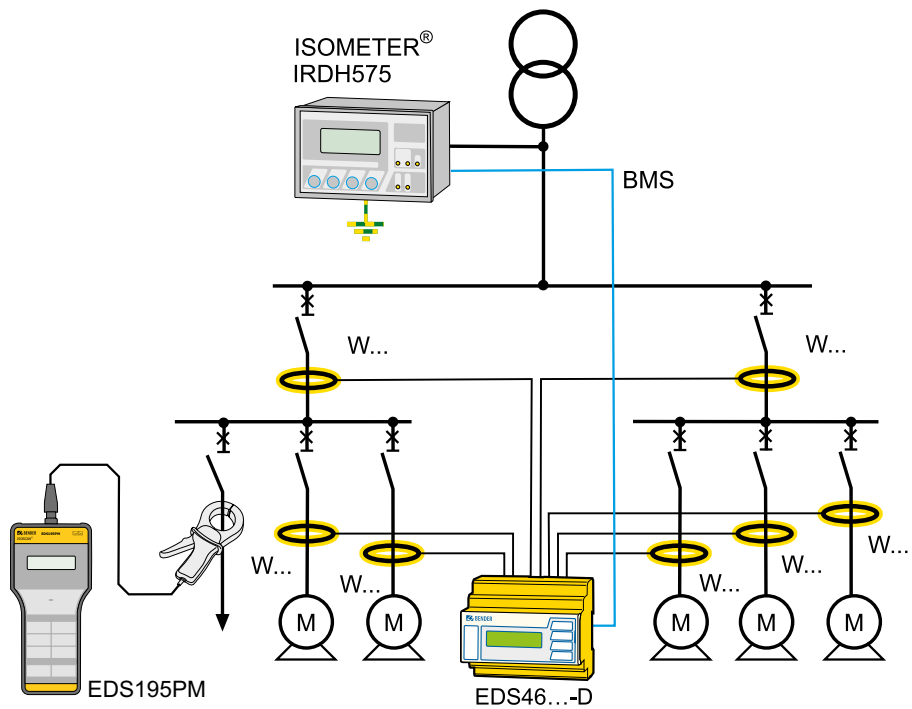

Equipment for insulation fault location EDS3090/3091 in unearthed systems (IT systems) with permanently installed equipment for insulation fault location EDS

**Operating elements of the PGH18...**

- 1 - On/off switch "ON" to activate the locating current
- 2 - Selector switch for the maximum locating current 25/10 mA or 2.5/1 mA
- 3 - Not visible: Magnetic adhesive strip at the back of the enclosure for fixing to metal parts (e.g. switchboard cabinet)
- 4 - 3 sockets for system coupling
- 5 - Socket for PE connection
- 6 - LED indicators:  
 Power On LED "ON"  
 Indication of the positive test pulse of the locating current  
 Indication of the negative test pulse of the locating current
- 7 - Microfuse 100 mA
- 8 - Panel plug for supply voltage

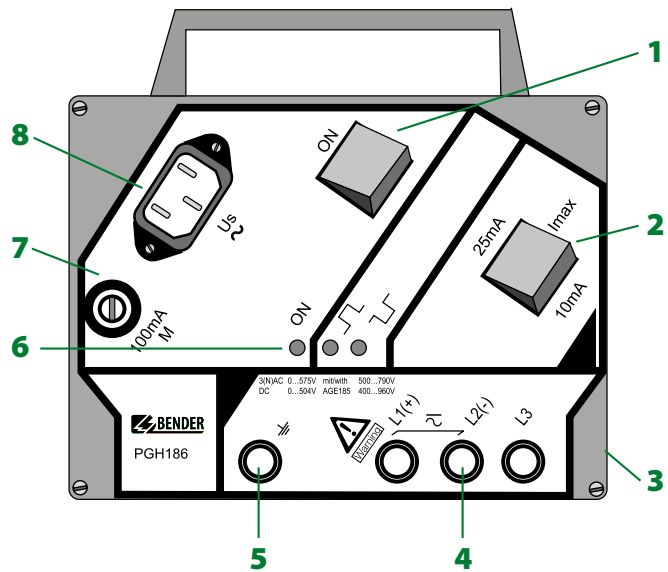

**Display and operating elements of the EDS195PM**

- 1 - Micro USB connection for charging the device's rechargeable battery
- 2 - BNC connection for the measuring clamp
- 3 - LC display, backlit  
3 lines à 16 characters
- 4 - LED "ALARM", lights when the response value is exceeded
- 5 - Button for the selection of the operating mode:  
 $I_{\Delta L}$  = Insulation fault location in IT systems (EDS mode)  
 $I_{\Delta n}$  = Residual current measurement in TN-S systems (RCM mode)
- 6 - Button for transformer selection  
 for  $I_{Tmax}$  = 50 mA: for  $I_{Tmax}$  = 5 mA:  
 P20 = PSA3020 = PSA3320  
 P52 = PSA3052 = PSA3352  
 P165 = PSA3165 = .....  
 W/WR = W.../WR... = W...-8000  
 WS = WS... = W...-8000
- 7 - "INFO" button:  
 - Device type  
 - Software version  
 - Current response values  $I_{\Delta L}$  and  $I_{\Delta n}$   
 - Setup status  
 ESC button:  
 to exit the menu function without changing parameters
- 8 - "MENU" button  
to toggle between the standard display and the menu selection
- 9 - On/Off switch
- 10 - "HOLD" button  
to store the currently indicated measured value  
Arrow up button: Parameter changes, scroll
- 11 - "RESET" button  
fault memory acknowledgement  
Arrow down button: Parameter changes, scroll
- 12 - Illumination button:  
to switch on the display lighting

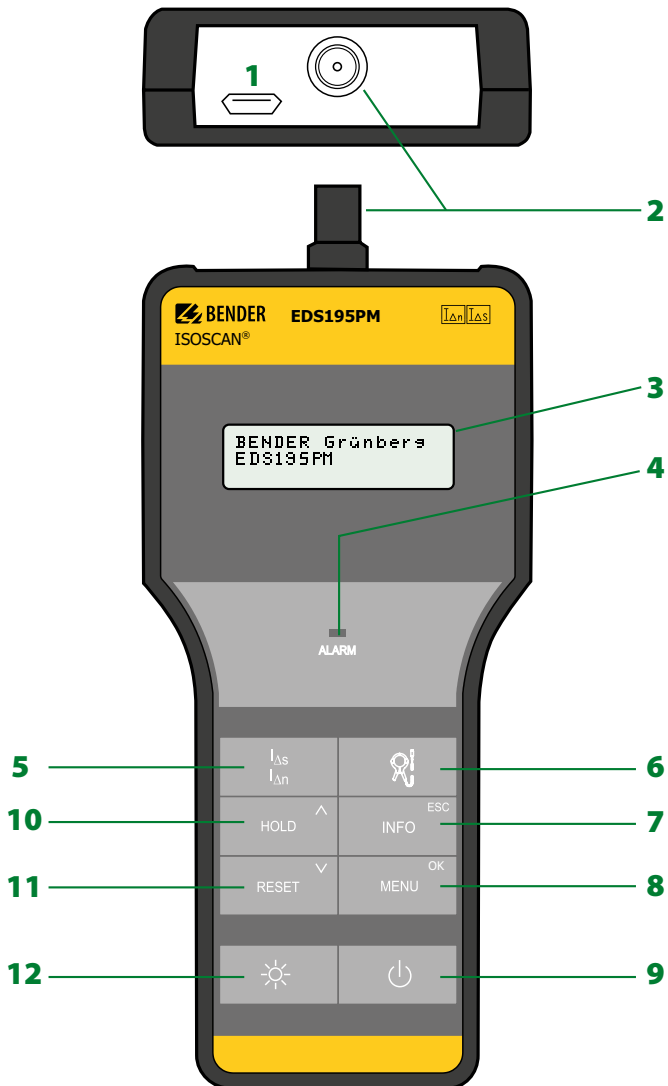

### Technical data EDS309...system

The technical data listed in this chapter apply to the components: PGH18..., EDS195PM, AGH185.

#### Environment/EMC

EMC	IEC 61326-2-4
Operating temperature	-10...+ 55 °C
Classification of climatic conditions acc. to IEC 60721:	
Stationary use (IEC 60721-3-3)	3K5 (except condensation and formation of ice)
Transport (IEC 60721-3-2)	2K3 (except condensation and formation of ice)
Storage (IEC 60721-3-1)	1K4 (except condensation and formation of ice)
Classification of mechanical conditions acc. to IEC 60721:	
Stationary use (IEC 60721-3-3)	3M4
Transport (IEC 60721-3-2)	2M2
Long-term storage (IEC 60721-3-1)	1M3

#### Other

Operating mode	continuous operation
Position of normal use	any
Weight EDS309...	≤ 7000 g
Weight EDS309... with PSA3165	≤ 8500 g
Weight EDS3092	≤ 9000 g
Dimensions, case W x H x D	430 x 340 x 155 mm
Documentation number	D00012

### Technical data PGH18...

#### Insulation coordination acc. to IEC 60664-1/IEC 60664-3

Rated insulation voltage	AC 500 V
Rated impulse voltage/pollution degree	4 kV/3

#### Nominal system voltage $U_n$

PGH183	AC 20...265 V 42...460 Hz, DC 20...308 V
PGH185	3AC/AC 20...575 V 42...460 Hz, DC 20...504 V
PGH186	3AC/AC 0...575 V 42...460 Hz, DC 0...504 V

#### Supply voltage

Supply voltage $U_s$	AC 230 V 50...60 Hz
Operating range of $U_s$	0.85...1.15 x $U_s$
Supply voltage $U_s$ version -13	AC 90...132 V/50...60 Hz

#### PGH 183, PGH 185:

Power consumption	≤ 3 VA
-------------------	--------

#### PGH 186:

Power consumption	≤ 6 VA
-------------------	--------

#### Locating current

##### PGH183:

Locating current, selectable, max.	1/2,5 mA
------------------------------------	----------

##### PGH185/186:

Locating current, selectable, max.	10/25 mA
------------------------------------	----------

##### PGH183/185/186

Test pulse	2 s
Idle time	4 s

#### Locating voltage

PGH186	DC 50 V
--------	---------

#### Other

Degree of protection, internal components DIN EN 60529 (VDE 0470-1)	IP40
Enclosure material	ABS plastic
Flammability class	UL94V-0
Weight	≤ 700 g
Dimensions	160 x 148 x 81 mm

### Technical data EDS195PM

#### Insulation coordination acc. to IEC 60664-1/IEC 60664-3

Rated insulation voltage	50 V
Rated impulse withstand voltage/pollution degree	0.8 kV/3

#### Supply voltage

Supply voltage $U_s$	accumulators, batteries or USB power supply unit
Accumulators	3 x NiMH ≥ 2000 mAh
Hours of operation (without display illumination)	≥ 150 h
Charging time	≤ 5 h
Size	AA R6
Batteries	3 x LR6 AA – 1.5 V
USB power supply unit:	
Primary:	100...240 V, 50...60 Hz
Secondary:	DC 5 V, +/- 10 %
Power consumption	≤ 0.5 W

#### Measuring circuit insulation fault location

Nominal system voltage	conductors uninsulated, including measuring clamp up to 600 V
Rated frequency	DC, 42...2000 Hz

#### Main circuit ( $I_{Lmax} = 50$ mA):

Measuring range	2 mA...50 mA
Measuring clamps	PSA3020, PSA3052, PSA3165
Response sensitivity $I_{\Delta L}$ adjustable	2...10 mA (5 mA)*
Relative uncertainty	±30 %/±2 mA of the reference value

#### Control circuit: ( $I_{Lmax} = 5$ mA)

Measuring range	0.2 mA...5 mA
Measuring clamps	PSA3320, PSA3352
Response sensitivity $I_{\Delta L}$ adjustable	0.2...1.0 mA (0.5 mA)*
Relative uncertainty 0.2...0.9 mA	±30 %/±0.2 mA of the reference value
Relative uncertainty 1...5 mA	±30 %/±2 mA of the reference value

#### Measuring circuit residual current

with measuring clamps	PSA3020, PSA3052, PSA3165
Measuring range	5 mA...10 A (crest factor up to 3)
Response sensitivity $I_{\Delta n}$ adjustable	10 mA...10 A (100 mA)*
Measuring clamps	PSA3320, PSA3352
Measuring range	2 mA...2 A (crest factor up to 3)
Response sensitivity $I_{\Delta n}$ adjustable	5 mA...1 A (100 mA)*
Frequency range	42...1000 Hz
Relative uncertainty, 42...60 Hz	±5 %
Relative uncertainty, 61...1000 Hz	±20 %
Hysteresis	20%
Harmonics, indication can be switched off	1st to 8th harmonic component

#### Inputs

Connection for measuring clamp	BNC socket
Connection for power supply unit (DC 5 V)	µUSB socket

#### Displays

LCD	3 x 16 characters, selectable illumination
LED	alarm

#### Other

Degree of protection, internal components DIN EN 60529 (VDE 0470-1)	IP40
Protection class acc. to IEC 60947-1, DIN EN 60947-1 (VDE 0660-100)	Class III
Enclosure material	ABS plastic
Flammability class	UL94V-0
Weight	≤ 350 g
Software version	D399 V1.2
Dimensions WxHxD	84x197x30 mm

(\*) = Factory settings

### Technical data measuring clamps

#### Electrical safety

Standard	IEC 61010-2-030
Pollution degree	2
Installation category	III
Operating voltage	600 V
Nominal insulation voltage	AC 600 V CAT III bzw. AC 300 V CAT IV

#### Transformation ratio

PSA30...	10 A/10 mA
PSA33...	1 A/0.1 mA
PSA3165	10 A/10 mA

#### Other

Degree of protection, internal components DIN EN 60529 (VDE 0470-1)	IP40
Protection class acc. to IEC 60947-1, DIN EN 60947-1 (VDE 0660-100)	Class III
Test port	BNC plug
Dimensions PSA3052/3352	216 x 111 x 45 mm
Dimensions PSA3020/3320	135 x 65 x 30 mm
Dimensions PSA3165	285 x 179 x 45 mm
Permissible cable diameter PSA3052/3352	52 mm
Permissible cable diameter PSA3052/3320	20 mm
Permissible cable diameter PSA3165	115 mm
Weight PSA3052/3352	≤ 700 g
PSA3020/3320	≤ 300 g
PSA3165	≤ 1300 g

### Technical data AGE185

#### Insulation coordination acc. to IEC 60664-1

Rated insulation voltage	AC 1000 V
Rated impulse voltage/pollution degree	4 kV/3
Nominal system voltage $U_n$	3AC, AC 500...790 V, DC 400...960 V, 42...460 Hz

#### Other

Degree of protection, internal components DIN EN 60529 (VDE 0470-1)	IP30
Type of connection/cable:	safety plug with green-yellow connecting wire 1 mm <sup>2</sup>
Weight	≤ 400 g
Dimensions W x H x D	84 x 197 x 30 mm
Weight	≤ 200 g
Dimensions W x H x D	88.5 x 42 x 21 mm

### Dimension diagram PSA3020/3320

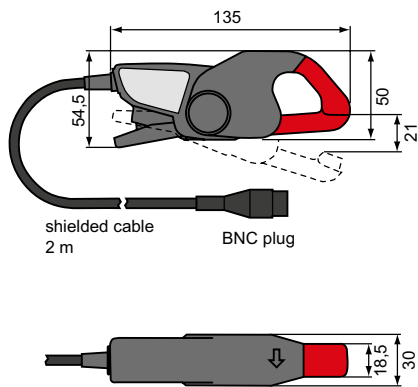

### Dimension diagram PSA3052/3352

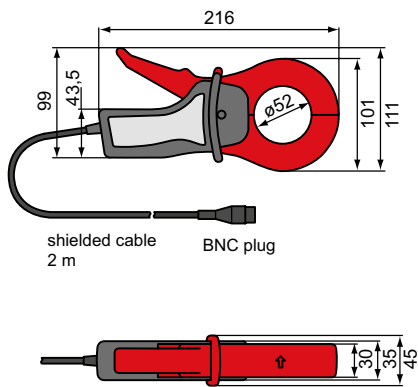

### Dimension diagram PSA3165

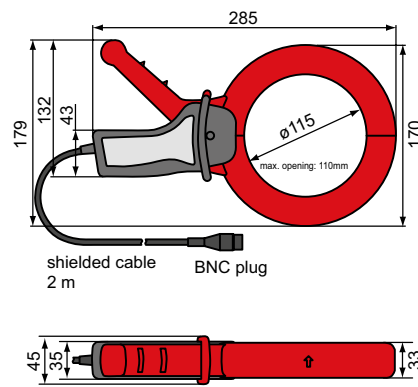

### Dimension diagram aluminium case

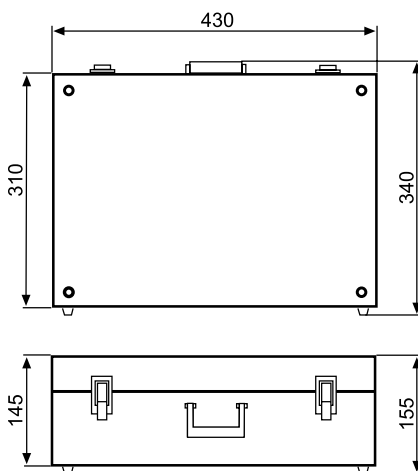



## Ordering information

Main circuits		Control circuits		Nominal voltage $U_n$		Supply voltage $U_s$	Type	Art. No.
with EDS	without EDS	with EDS	without EDS	AC	DC	AC		
EDS460/490	–	–	–	20...575 V, 42...460 Hz	20...504 V	–	EDS3090	B91082026
–	■	–	–	20...575 V, 42...460 Hz	20...504 V	230 V, 50...60 Hz	EDS3090PG	B91082021
						90...132 V, 50...60 Hz	EDS3090PG-13	B91082022
				0...575 V, 42...460 Hz	0...504 V	230 V, 50...60 Hz	EDS3096PG	B91082025
						90...132 V, 50...60 Hz	EDS3096PG-13	B91082029
–	–	EDS461/491	–	20...265 V, 42...460 Hz	20...308 V	–	EDS3091	B91082027
–	–	–	■	20...265 V, 42...460 Hz	20...308 V	230 V, 50...60 Hz	EDS3091PG	B91082023
						90...132 V, 50...60 Hz	EDS3091PG-13	B91082024
–	■	–	■	20...265 V, 42...460 Hz	20...308 V	230 V, 50...60 Hz	EDS3092PG	B91082030
–	■	–	■	20...575 V, 42...460 Hz	20...504 V	230 V, 50...60 Hz		
–	■	–	–	20...575 V, 42...460 Hz	20...504 V	230 V, 50...60 Hz		
–	■	–	–	20...575 V, 42...460 Hz	20...504 V	230 V, 50...60 Hz	EDS3096PV	B91082031

## Suitable system components

Designation	Nominal voltage $U_n$		Type	Art. No.
	AC	DC		
Measuring clamp 115 mm for EDS3090... and EDS3096...	–	–	PSA3165	B980852
Coupling device to extend the voltage range of the PGH185/186	500...790 V/ 42...460 Hz	400...960 V	AGE185	B980305
Accessories for fault location in diode-decoupled systems	–	–	EDS165-SET	B91082007

## Scope of delivery

Insulation fault locator	Locating current injector	Measuring clamps 20 mm	Measuring clamps 52 mm	Type
EDS195PM	–	PSA3020	PSA3052	EDS3090
EDS195PM	PGH185	PSA3020	PSA3052	EDS3090PG
EDS195PM	PGH185-13	PSA3020	PSA3052	EDS3090PG-13
EDS195PM	PGH186	PSA3020	PSA3052	EDS3096PG
EDS195PM	PGH186-13	PSA3020	PSA3052	EDS3096PG-13
EDS195PM	–	PSA3320	PSA3352	EDS3091
EDS195PM	PGH183	PSA3320	PSA3352	EDS3091PG
EDS195PM	PGH183-13	PSA3320	PSA3352	EDS3091PG-13
EDS195PM	PGH183	PSA3320	PSA3352	EDS3092PG
	PGH185	PSA3020	PSA3052	
EDS195PM	PGH186	–	2 x PSA3052	EDS3096PV

## Standards

Observe the applicable national and international standards. The EDS309... series meets the requirements of the following standards for the erection of electrical installations:

- IEC 60364-4-41 (modified): Low-voltage electrical installations - Part 4-41: Protection for safety - Protection against electric shock; German implementation HD 60364-4-41

The EDS309... type range complies with the device standards:

- DIN EN 61557-9 (VDE 0413-9): IEC 61557-9: Electrical safety in low-voltage distribution systems up to 1000 V a.c. and 1500 V d.c. - Equipment for testing, measuring or monitoring of protective measures - Part 9: Equipment for insulation fault location in IT systems; German version EN 61557-9
- IEC 61010-1:2001 Safety requirements for electrical equipment for measurement, control, and laboratory use - Part 1: General requirements German version EN 61010-1

## Device selection for IT systems with integrated equipment for insulation fault location

Type of distribution system	AC, DC, AC/DC (mixed systems)		
Application range	Main circuits	Control circuits	Main circuits or Control circuits

### Insulation monitoring device ISOMETER®/Locating current injector PGH



Type	IRDH575	IRDH575	iso685-x-P	isoxx1685xP
Nominal system voltage $U_n$	-B1: 3AC, AC 20...575 V, DC 20...504 V -B2: 3AC, AC 340...760 V, DC 340...575 V	3AC, AC 20...150 V, DC 20...150 V	AC 0...690 V, DC 0...1000 V	isoLR1685DP: AC 0...690 V, DC 0...690 V iso1685DP: AC 0...1000 V, DC 0...1500 V
$U_5$ DC 19,2...72 V	IRDH575B1-427	IRDH575B1-4227	—	—
$U_5$ AC 88...264 V/DC 77...286 V	IRDH575B1-435, IRDH575B2-435	IRDH575B1-4235	—	—
$U_5$ AC/DC 24...240 V	—	—	iso685-x-P	—
$U_5$ DC 18...30 V	—	—	—	isoxx1685xP
Locating current $I_L$	10/25/50 mA	1/2,5 mA	1/1.8/2.5/5/10/25/50 mA	1/2.5/5/10/25/50 mA
Response values	1 k $\Omega$ ... 10 M $\Omega$	1 k $\Omega$ ... 10 M $\Omega$	1 k $\Omega$ ... 10 M $\Omega$	isoLR1685DP: 20 $\Omega$ ... 100 k $\Omega$ iso1685DP: 200 $\Omega$ ... 1 M $\Omega$
LC display	4 x 20 characters	4 x 20 characters	graphic display	graphic display
Alarm relay	3 changeover contacts	3 changeover contacts	2 changeover contacts	3 changeover contacts
Interface/protocol	RS-485 (BMS)	RS-485 (BMS)	RS-485 (BS)	RS-485 (BS)
Address range	1...30	1...30	1...90	1...90

### Insulation fault locator



Type	EDS195PM
LC display	3 x 16 characters
Evaluating current $I_{\Delta L}$	0.2...50 mA
Response value	0.2...1/2...10 mA selectable

### Messzangen

Application range	Main circuits	Control circuits
-------------------	---------------	------------------



Type	PSA3020	PSA3052	PSA3165 (optional)	PSA3320	PSA3352
20 mm	■			■	
52 mm		■			■
115 mm			■		

### Complete systems

Type	EDS3090		EDS3091
Comprising	Aluminium case, EDS195PM, PSA3020, PSA3052, power supply unit	Aluminium case, EDS195PM, PSA3020, PSA3052, power supply unit	Aluminium case, EDS195PM, PSA3320, PSA3352, power supply unit

## Device selection for IT systems without a permanently installed equipment for insulation fault location

Application	Main circuit		Control circuit
	energised	offline	energised

### Locating current injector PGH



Nominal system voltage $U_n$	3AC, AC 20...575 V DC 20...504 V	3AC, AC 0...575 V DC 0...504 V	AC 20...265 V, DC 20...308 V
$U_5$ AC 230 V	PGH185	PGH186	PGH183
$U_5$ AC 90...132 V	PGH185-13	PGH186-13	PGH183-13
Locating current $I_1$ max.	10/25 mA	10/25 mA	1/2.5 mA

### Insulation fault locator



Type	EDS195PM
LC display	3 x 16 characters
Evaluating current $I_{\Delta L}$	0.2...50 mA
Response value	0.2...1/2...10 mA selectable

### Measuring clamps



Type	PSA3020	PSA3052	PSA3165 (optional)	PSA3320	PSA3352
20 mm	■			■	
52 mm		■			■
115 mm			■		

### Components EDS309...

Device type	Aluminium case with carrying handle	Operating manual	EDS195PM with Accessories					PGH18... with accessories for						Measuring clamps				
			Insulation fault locator	Clamping connector on 4 mm	Adapter BNC/4mm connector for curr. transform	Adapter BNC-PS2 for WF-CT, optional	Plug power supply for EDS195PM	Locating current injector	Supply cable for PGH18...	Safety measuring cable, black	Safety measuring cable, green/yellow	Safety claw grip, black	Safety claw grip, green/yellow	Coupling device, optional (EDS309GPV only: in the scope of delivery)	Measuring clamps 20 mm	Measuring clamps 52 mm	Measuring clamps 115 mm, optional	EDS-Set, optional
EDS3090	1	1	EDS195PM	1	1	1	1								PSA3020	PSA3052	PSA3165	1
EDS3090PG	1	1	EDS195PM	1	1	1	1	PGH185	1	3	1	3	1	AGE185	PSA3020	PSA3052	PSA3165	1
EDS3090PG-13	1	1	EDS195PM	1	1	1	1	PGH185-13	1	3	1	3	1	AGE185	PSA3020	PSA3052	PSA3165	1
EDS3091	1	1	EDS195PM	1	1	1	1								PSA3320	PSA3352		1
EDS3091PG	1	1	EDS195PM	1	1	1	1	PGH183	1	3	1	3	1		PSA3320	PSA3352		1
EDS3091PG-13	1	1	EDS195PM	1	1	1	1	PGH183-13	1	3	1	3	1		PSA3320	PSA3352		1
EDS3092PG	1	1	EDS195PM	1	1	1	1	PGH183 PGH185	2	6	2	6	2		PSA3320 PSA3020	PSA3352 PSA3052		1
EDS3096PG	1	1	EDS195PM	1	1	1	1	PGH186	1	3	1	3	1	AGE185	PSA3020	PSA3052	PSA3165	1
EDS3096PG-13	1	1	EDS195PM	1	1	1	1	PGH186-13	1	3	1	3	1	AGE185	PSA3020	PSA3052	PSA3165	1



**BENDER Group**