

READ AND SAVE THESE INSTRUCTIONS

Turbine Vortex Auto-Duster™ Heater

Owner's Manual



English

Model

LP2000HTR

LP2000HTR-G

LP2000HTR-W

LP2000HTR-T

LP2000HTR-ER

Form #LP2000HTR
© 2021 ® Registered Trademark/TM Trademark of
LivePure LLC. Manufactured exclusively for LivePure
LLC. All rights reserved.



Table of Contents

Know Your Heater

Safety Instructions.....	1
Warnings.....	3

Operating Your Heater

Initial Setup.....	4
Operation.....	5
Control Panel.....	6
Remote Control.....	7

Maintenance & Filter Replacement

Cleaning the Surface.....	8
Cleaning the Pre-Filter.....	8
Replacing the Pre-Filter.....	9
Replacing the Remote Battery.....	9

Heater Assistance

Troubleshooting.....	10
Technical Support.....	10

Warranty

1 Year Guarantee.....	11
-----------------------	----

Thank you for purchasing the Turbine Vortex 1500 WATT Heater by LivePure® Company. Please read and save these instructions to receive the maximum benefit and performance from your heater.

READ AND SAVE THESE INSTRUCTIONS!

Important Safety Instructions: Read all instructions before using this heater.

- This appliance is for indoor use only.
- Rating: This unit must be only connected to a 120V / 60 Hz earthed outlet.
- Installation must be in accordance with regulations of the country where the unit is used.
- If you are in any doubt about the suitability of your electrical supply have it checked and, if necessary, modified by a qualified electrician.
- This heater has been tested and is safe to use. However, as with any electrical appliance - use it with care.
- Disconnect the power from the unit before dismantling, assembling or cleaning.
- **Avoid** touching any moving parts within the appliance.
- **Never** insert fingers, pencils or any other objects through the guard
- This appliance can be used by children aged from 8 years and above and persons with reduced physical, sensory or mental capabilities or lack of experience and knowledge if they have been given supervision or instruction concerning use of the appliance in a safe way and understand the hazards involved. Children shall not play with the appliance. Cleaning and user maintenance shall not be carried out by children.
- Children aged from 3 years and less than 8 years shall only switch on/off the appliance provided that it has been placed or installed in its intended normal operating position and they have been given supervision or instruction concerning use of the appliance in a safe way and understand the hazards involved. Children aged from 3 years and less than 8 years shall not plug in, regulate, or clean the appliance or perform user maintenance
- Children under 3 years should be kept away unless continuously supervised.

- Some parts of this product can become very hot and cause burns. Particular attention has to be given where children and vulnerable people are present.
- **Do not** clean the unit by spraying it or immersing it in water.
- **Never** connect the unit to an electrical outlet using an extension cord. If an outlet is not available, one should be installed by a qualified electrician.
- **Never** operate this appliance if the unit, cord or plug is damaged. Ensure the power cord is not stretched, exposed to sharp object edges, or routed under the unit.
- Any service other than regular cleaning should be performed by an authorised service representative. Failure to comply could result in a voided warranty.
- **Never** use the plug as a switch to start and turn off the heater. Use the provided power button located on the control panel.
- **Do not** use an external timer.
- **Do not** cover the air inlet or outlet, or place items close to the unit which may restrict airflow, as this may present a fire risk.
- The heater must not be located immediately below a power outlet.
- **Always** place the unit on a dry and stable surface. Do not move or tilt the unit
- **Avoid** keeping the unit in direct sunlight for a long period of time.
- The heater is designed to be used at temperatures above -4° F (-20° C). If it is exposed to temperatures below this, it must be allowed to warm above this level before operation.
- **Do not** attempt to repair, disassemble or modify the appliance. This unit contains no user-serviceable parts.
- **Always** unplug or disconnect the appliance from the main power supply when not in use, or when moving or cleaning it. Do not pull the cord to unplug the heater.
- Keep the heater clean. **Do not** allow any object to enter the ventilation or exhaust opening as this may cause electric shock, fire, or damage to the heater.

- **Do not** use the appliance for anything other than its intended use. It is designed for domestic indoor use only.
- There may be a trace of odor during the first few minutes of initial use, or after a period of storage. This is normal and will quickly disappear.
- This appliance has hot parts inside. **Do not** use it in areas where gasoline, paint, or any flammable liquids are used or stored.
- This appliance is not intended for use in bathrooms, laundry areas and similar humid locations.
- **Never** locate this appliance where it may fall into a bathtub or otherwise become exposed to water.
- The remote contains a lithium battery, keep out of reach of small children. Seek medical advice if swallowed.
- To prevent battery leakage: Remove the battery from the remote if exhausted or before long periods of storage.
- **Do not** cover or restrict the airflow. Do not use in dusty environment.
- **Do not** run cord under carpeting.
- **Do not** cover cord with throw rugs, runners, or similar coverings. Do not route under furniture or appliances.
- For safety and maximum performance the minimum distance from a wall or objects should be 20 inches.
- Contact the LivePure® Customer Service Center when service or repair is required.
- **Do not** disassemble the appliance as incorrect reassembly may result in an electric shock.

WARNING:

To reduce the risk of fire or electrical shock, DO NOT use this appliance with any solid state Speed Control Device or any variable speed controllers.

Specifications:

Voltage (V)	Frequency (Hz)	Rotation Angle	Cord Length (ft)	Power (w)
120	60	60°	5.9	1500
Weight (lbs)	Height (in)	Width (in)	Depth (in)	Timer (h)
4.9	7.1	7.1	14.5	12

Features:

- High speed motor with fan mode and 2 heat settings
- Swing function
- 12 hour standby timer
- Remote control allowing all functions to be changed
- Cleanable pre-filter

Initial Setup:

- Pull heater out of box and remove any packaging
- Plug power cord into wall outlet
- Turn on unit by pressing ON/OFF button
- Refer to **Page 8** for more information on operating your heater

Operation:

Your heater may be operated by using either the manual controls located on the front of the fan or by using the remote control.

Power Switch on the Back of the Unit

Use this switch to turn the heater ON and OFF. This should be used to turn off the appliance before leaving unattended.

Safety Tip Over Switch

There is a safety tip over switch on the bottom of the heater. If the heater is knocked over or placed on an uneven surface it will automatically shut off. The heater will automatically come back on once placed upright on an even surface.

Figure 1

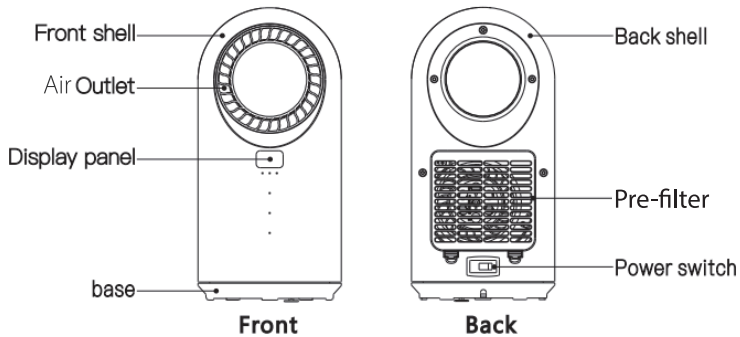

Control Panel and Settings:

Fan Low High

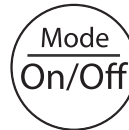
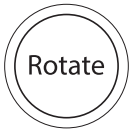
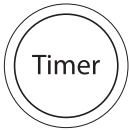
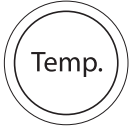

Figure 2

TEMP. BUTTON

Press repeatedly to increase the desired room temperature. After pressing the temp button the desired temperature will flash for 3 seconds, before the unit reverts to showing the room temperature. When the desired temperature has been reached the unit will change into fan mode.

FIGURE 2

TIMER BUTTON

Press repeatedly to increase the run time in 1 hour intervals. The timer can be set between 1 hour and 12 hours. The display will show the duration currently set. When the timer is set, the light will illuminate next to the timer button. To cancel the timer, repeatedly press the timer button until 00 is shown.

ROTATE BUTTON

Press to turn the rotate function on and off. When the rotate function is on the horizontal direction of the airflow is slowly moved from side to side and the light will illuminate next to the rotate button.

FIGURE 2

MODE BUTTON

Press to cycle through the three available modes: fan, low heat and high heat.

ON/OFF BUTTON

Press to turn the bladeless heater ON and OFF during normal use.

Remote Control:

Your heater comes with a remote control that can change all settings.

ON/OFF BUTTON

Press to turn the bladeless heater ON and OFF. **FIGURE 3**

MODE BUTTON

Press to cycle through the three available modes: fan, low heat and high heat. **FIGURE 3**

TEMP. BUTTON

Press repeatedly to increase (+) or decrease (-) the desired room temperature. After pressing the temp button the desired temperature will flash for 3 seconds, before the unit reverts to showing the room temperature. When the desired temperature has been reached the unit will change into fan mode. **FIGURE 3**

TIMER BUTTON

Press repeatedly to increase the running time in 1 hour intervals. The timer can be set between 1 hour and 12 hours. The display will show the duration currently set. When the timer is set, the light will illuminate next to the timer button. To cancel the timer, repeatedly press the timer button until 00 is shown. **FIGURE 3**

ROTATE BUTTON

Press to turn the rotate function on and off. When the rotate function is on the horizontal direction of the airflow is slowly moved from side to side and the light will illuminate next to the rotate button. **FIGURE 3**

Figure 3

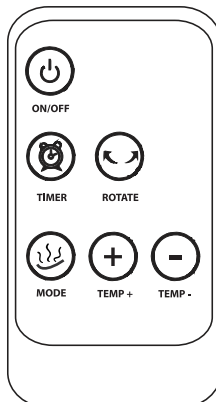

WARNING: Shut off the unit and unplug it before cleaning or performing any maintenance.

Cleaning the Surface:

1. Clean the heater with a duster or a soft damp cloth.
2. Do not use chemical solvents (such as benzene, alcohol or gasoline) as they may cause irreversible damage.
3. Make sure no water enters the control panel or gaps in the casing.
4. Do not run the unit until completely dry.
5. Place the heater in its original box or cover to protect it from dust when not in use.
6. Store it in a cool dry place.

Cleaning the Auto Duster™ Pre-Filter:

1. Turn off and unplug heater from power source.
2. Push up on prongs to release back grille. **FIGURE 4**
3. Remove filter from grille.
4. Vacuum filter with vacuum's brush attachment. Hold down pre-filter to prevent being sucked into vacuum. DO NOT use water any liquid or detergent to clean the pre-filter.
5. If needed, clean grille with a soft, damp cloth.
6. Align filter in grille and ensure filter is laying flat.
7. Insert top tabs of grille into heater.
8. Push grille towards fan until the bottom prongs securely snap into place.

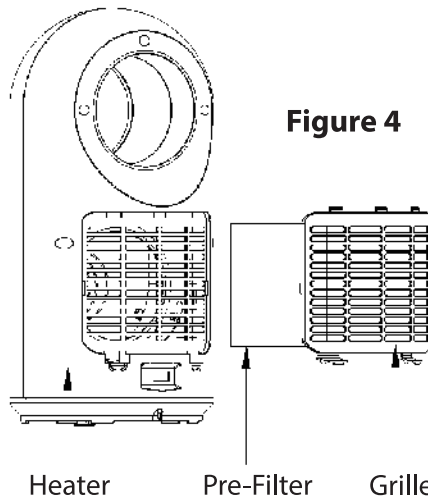

Filter Ordering:

Although the Auto Duster™ pre-filter is meant to be permanent, it may lose efficiency over time. If the pre-filter is no longer easily cleanable, replacements are available at www.livepureshop.com.

Model #	Filter Part #	Type
LP2000HTR-G LP2000HTR-W LP2000HTR-T LP2000HTR-ER	LP-PF2000-HTR	Replacement Pre-Filter, 2 Pack

Replacing Remote Batteries

The remote control is powered by a Lithium Button Cell Battery (CR2025). Should the remote become unresponsive, replace the battery following the instructions below:

1. Turn over the remote and press tab "A" to the right **FIGURE 5**
2. Slide out the battery tray "B" **FIGURE 6**
3. Replace the battery with the same type, ensuring the positive side is facing upwards **FIGURE 7**
4. Slide the battery tray back in

Figure 5

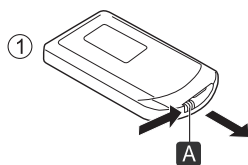

Figure 6

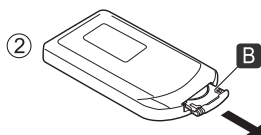
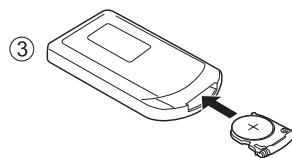

Figure 7



WARNING



Keep the lithium battery out of reach of small children.

Small children may accidentally swallow it. If swallowed, call your doctor immediately.

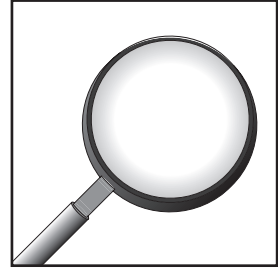

Problem: No Power

1. Make sure the power cord is plugged in
2. Make sure there is power to the socket
3. Ensure the power switch on the back of the unit is in the "On" position

Problem: Strange Odor

This is normal for new units and when the unit is used for the first time in a while. The fan motor may produce an odor which will dissipate within a week of use. No action is required.

Problem: Strong Vibrations & Loud Noise

1. Make sure the unit is placed on a flat surface
2. Try putting an anti-vibration mat underneath the unit
3. Unit may be damaged. Discontinue use and contact customer service.

WARNING: DO NOT attempt to take apart the unit by yourself. Doing so may void your warranty and cause damage to the heater or personal injury.

Technical Support

If you need any assistance with setup, operation or parts for your new LivePure® Heater, please call us. Our technical support staff is ready to help!

USA: 888-855-5426

Canada: 888-855-5426

Hours of operation are from 8:00 AM to 6:00 PM EST
Or chat with us on our website at www.livepureshop.com

Warranty

1 Year Guarantee

LivePure®, LLC makes the following limited warranty to the original residential user or consumer purchaser of the Turbine Vortex 1500 WATT Heater: for one (1) year from date of purchase, if the heater's fan motor fails when operated and maintained according to instructions attached to or furnished with the product, LivePure®, LLC will repair or, at our option, replace your product with an identical or comparable heater. If the heater cord or control panel fails within one (1) year from date of purchase when operated and maintained according to instructions attached to or furnished with the product, LivePure®, LLC will repair or, at our option, replace your heater with an identical or comparable product. Failure to clean and/or maintain the product, will invalidate this warranty.

IF THE ORIGINAL RESIDENTIAL USER OR CONSUMER PURCHASER CEASES TO OWN THE TURBINE VORTEX 1500 WATT HEATER, THIS WARRANTY AND ANY IMPLIED WARRANTY WHICH THEN REMAINS IN EFFECT, INCLUDING BUT NOT LIMITED TO ANY IMPLIED WARRANTY OF MERCHANTABILITY OR FITNESS FOR A PARTICULAR PURPOSE, ARE VOIDED. THIS WARRANTY IS IN LIEU OF ALL OTHER EXPRESS WARRANTIES. THE DURATION OF ANY IMPLIED WARRANTY, INCLUDING BUT NOT LIMITED TO ANY IMPLIED WARRANTY OF MERCHANTABILITY OR FITNESS FOR A PARTICULAR PURPOSE IS EXPRESSLY LIMITED TO THE PERIOD OF THE EXPRESS WARRANTY SET FORTH ABOVE.

This warranty is voided if your Turbine Vortex 1500 WATT Heater is not purchased and used in the USA or Canada.

This warranty excludes and does not cover defects, malfunctions, or failures of the heater which were caused by repairs by persons not authorized by us, use of parts, or accessories not authorized by us, mishandling, possession, or unreasonable use, including failure to provide reasonable and necessary maintenance. This warranty does not cover heaters used in commercial applications. There are no express or implied warranties as to commercial purchasers or users.

To obtain service, contact LivePure® Customer Service at 888-855-5426. You will be responsible for insurance and freight or other transportation to our factory service center. We will return the heater freight prepaid. The heater should be properly packaged to avoid damage in transit since we will not be responsible for any such damage. Proof of purchase is required when requesting warranty service. The purchaser must present sales receipt or other document that establishes proof of purchase.

IN NO EVENT SHALL LIVEPURE® COMPANY BE LIABLE FOR DIRECT, INDIRECT, SPECIAL, CONSEQUENTIAL OR INCIDENTAL DAMAGES IN EXCESS OF THE PURCHASE PRICE OF THE HEATER. YOUR SOLE REMEDY WILL BE REPAIR OR REPLACEMENT AS PROVIDED ABOVE. SOME AMERICAN STATES AND CANADIAN PROVINCES DO NOT ALLOW:

- LIMITATIONS ON HOW LONG AN IMPLIED WARRANTY LASTS;
 - THE EXCLUSION OR LIMITATION OF DIRECT, INDIRECT, SPECIAL, INCIDENTAL, OR CONSEQUENTIAL DAMAGES;
- THE EXCLUSION OR INVALIDITY OF EXPRESS OR IMPLIED WARRANTIES IF THE USER CEASES TO OWN THE FAN;
- THE LIMITATION OF THE REMEDIES AND RECOURSES AVAILABLE TO THE PURCHASER; OR THE INVALIDITY OF AN EXPRESS WARRANTY WHEN A PRODUCT IDENTIFIED BY BRAND NAME IS NOT USED (UNLESS SPECIFIC CONDITIONS ARE FULFILLED);

SO THE ABOVE LIMITATIONS OR EXCLUSIONS MAY NOT APPLY TO YOU. THIS WARRANTY GIVES YOU SPECIFIC LEGAL RIGHTS AND YOU MAY ALSO HAVE OTHER RIGHTS WHICH VARY FROM STATE TO STATE OR PROVINCE TO PROVINCE.