

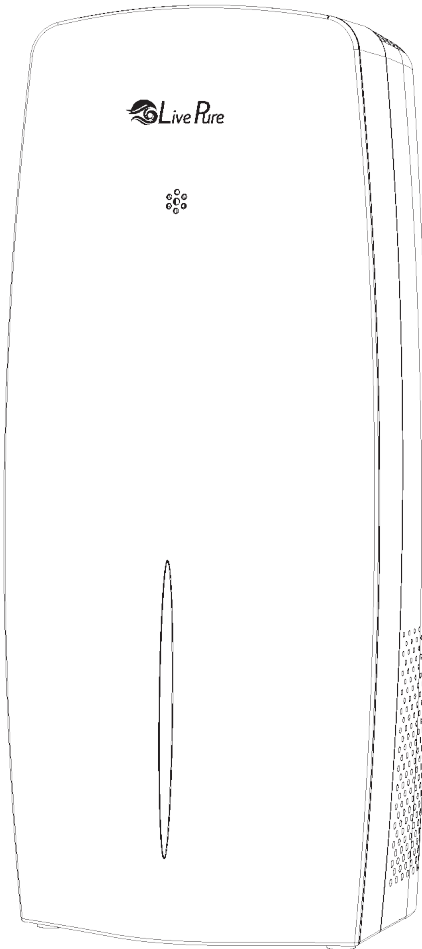

Air Purifier & Humidifier

Owner's Manual



English

Models:

**LP460APH
LP460APH-BLK
LP460APH-GRA
LP460APH-SAG
LP460APH-WHT**

Form #LP460APH

20220627

©2022 Registered Trademark/TM Trademark of LivePure

Manufactured exclusively for LivePure

All rights reserved

Table of Contents

At A Glance

Safety Warnings.....	1
----------------------	---

Using Your Product

Initial Set Up.....	4
Operation.....	5
Control Panel.....	6
Remote Control.....	7

Maintenance

Cleaning the Filters.....	9
Cleaning the Synthetic Wick.....	10
Cleaning the Unit.....	11

Humidifier Assistance

Troubleshooting.....	12
Filter/Wick Ordering.....	13
Technical Support.....	13

Warranty

3-Year Guarantee.....	14
-----------------------	----

Safety Warnings

Your safety and the safety of others are very important.

We have provided many important safety messages in this manual and on your appliance. Always read and obey all safety messages.



This is the safety alert symbol. This symbol alerts you to potential hazards that can kill or hurt you and others.

All safety messages will follow the safety alert symbol and either the word "DANGER" or "WARNING." These words mean:

 **DANGER**

You can be killed or seriously injured if you don't immediately follow instructions.

 **WARNING**

All safety messages will tell you what the potential hazard is, tell you how to reduce the chance of injury, and tell you what can happen if the instructions are not followed.

IMPORTANT SAFETY INSTRUCTIONS

This appliance has a polarized plug (one blade is wider than the other). To reduce the risk of electric shock, this plug is intended to fit into a polarized outlet only one way. If the plug does not fit fully into the outlet, reverse the plug. If it still does not fit, contact a qualified electrician. Do not attempt to defeat this safety feature.

Do not operate appliance with a damaged cord or plug. Discard product or return to an authorized service facility for examination or repair.

Unplug appliance before servicing.

Do not run cord under carpeting. Do not cover cord with throw rugs, runners, or similar covering. Do not route cord under furniture, or appliances. Arrange cord away from traffic area and where it will be tripped over.

READ AND SAVE THESE INSTRUCTIONS

WARNING: To reduce the risk of fire or electrical shock, DO NOT use the appliance with any Solid-State Speed Control Device.

WARNING: To reduce the risk of fire or electrical shock and injury to persons, DO NOT use in a window.

Safety Warnings

READ AND SAVE THESE INSTRUCTIONS!

Important Safety Instructions: Read all instructions before using this product.

- This product may not work properly on an uneven surface.
- ALWAYS place it on a firm, level, and water resistant surface.
- ALWAYS place the product at least six inches away from walls, heat sources, and electrical appliances such as stoves, radiators, or heaters.
- ALWAYS place the product in an area that is out of the reach of children.
- Before using the product, extend the cord and inspect for any signs of damage. DO NOT use the product if the cord has been damaged.
- This product has a polarized plug (one blade is wider than the other) as a safety feature. This plug will fit into a polarized outlet only one way. If the plug does not fit fully into the outlet, reverse the plug. If it still does not fit, contact a qualified electrician. DO NOT attempt to defeat or override this safety feature.
- ALWAYS UNPLUG AND EMPTY the humidifier tank when it is not in operation or while it is being cleaned.
- Use only fresh, clean tap water when filling the tank. DO NOT use hot water.
- You should never leave the humidifier unattended in a closed room. Always leave a door partially open.
- This device complies with part 18 of the FCC Rules.
- DO NOT add detergents, chemical solutions or medications.
- DO NOT touch water in water tank or components in water when unit is turned on.
- DO NOT overfill the water tank.
- Avoid spilling water on the unit while refilling the water tank.
- ALWAYS lift the product by the handle or base, DO NOT lift by the tank.
- DO NOT clean with detergents or chemical solutions.

Safety Warnings

- Keep away from children under the age of 8 unless supervised by an adult.
- For indoor use only.
- NEVER drop or insert any object into any openings.
- DO NOT run cord under carpeting, throw rugs or runners.
- DO NOT route cord under furniture or appliances. Arrange cord away from traffic area and where it will not be tripped over.
- NEVER block the air openings, grilles/outlets.
- NEVER place the product on a soft surface, such as a bed or sofa, as this could cause the unit to tip over, blocking the air intake or outtake opening.
- DO NOT place anything on top of the unit.
- DO NOT attempt to repair or adjust any electrical or mechanical functions on this unit, doing so will void your warranty.

If you need any assistance with setup, operation, or parts for your new LivePure product, please call us. Our technical support staff is ready to help!

USA/Canada: 888-855-5426
Email: info@livepureshop.com

Hours of operation are from 8:00 AM to 6:00 PM EST.
You may also contact us online at:

www.livepureshop.com

Initial Set Up

1. Remove the product from packaging and place on a sturdy, flat surface.
2. Unravel and straighten the cord before use.
3. Remove the top cover from the unit.
4. Use a pitcher to add fresh, clean tap water to tank. DO NOT overfill.
5. Reattach top cover.

WARNING: Never fill the humidifier with hot water.

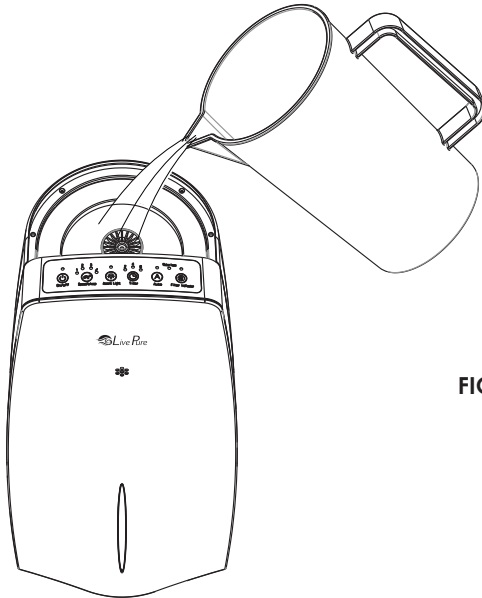

FIGURE 1

Operation

Power ON: Follow the *initial setup* instructions. Plug product into wall outlet. On product, press power switch to ON. Product will beep and light up as indication that it is working.

Power OFF: Press power switch to OFF. Empty water tank.

Refill Water Tank: See *initial setup* for instructions on refilling water tank. DO NOT overfill. If tank is empty, product will still run as an air purifier. Refill the tank to use the humidifier function. When tank is empty the “Waterless” light will turn on. This will automatically turn off once the tank is refilled.

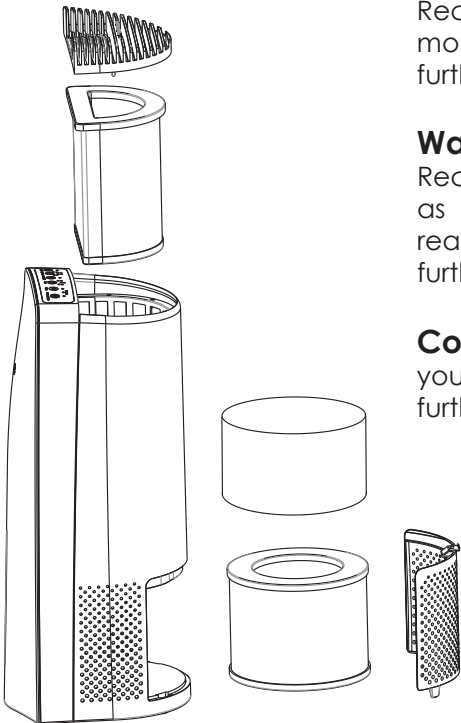

HEPA Filter: Helps purify your air. Recommended to replace every 6 months. See *Filter Maintenance* for further instructions .

Water Wick: Helps purify your water. Recommended to clean or replace as needed due to environmental reasons. See *Filter Maintenance* for further instructions .

Control Panel: How you operate your machine. See *Control Panel* for further instructions .

FIGURE 2

Control Panel

FIGURE 3

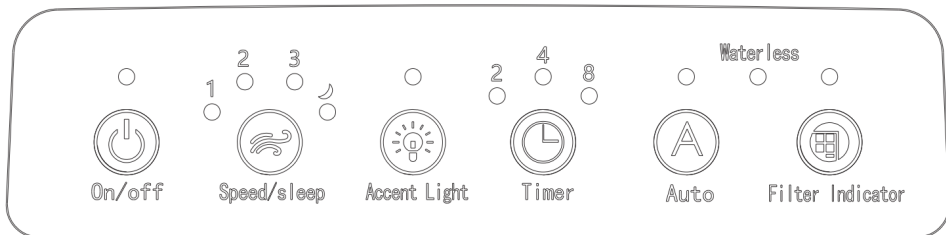

On/Off: Press button to power humidifier on or off.

Speed/Sleep: By default, the machine will start running on low speed. Press the button once to run on medium speed, twice for high speed and a third time for sleep mode. Press button again to turn off sleep mode and return to low speed.

Accent Light: The accent light will automatically turn on when you power on your unit. Press the button to turn it off.

Timer: Press button to set timer. Press once for 2 hours, press twice for four hours and three times for 8 hours. Press through all options to not set a timer. Unit will automatically shut off after the set time runs out.

Auto: Press button to have the unit work in Auto mode. The unit's running speed will be based on the room's humidity. The unit will run on high speed for humidity below 40%. medium speed for humidity between 41-69%, and low speed for humidity above 70%. The product will try to get the room's humidity between 41-69% and adjust its speeds accordingly. Press Auto button again to turn off Auto mode.

Filter Indicator: This button will light up when it is time to clean your HEPA filter. After the filter is cleaned or replaced, press and hold the filter indicator button to reset it.

6

Waterless: This will light up when your unit is out of water. Please refill the tank following instructions on *Initial Set Up*.

Remote Control

Using the Remote:

Your remote comes with a battery installed and does not need to be programmed. Before using your remote for the first time, you must take out the pull tab. To use remote, make sure to point it at the front of the unit. The remote will not work when pointed to the backside of the unit.

On/Off: Press button to power product on or off.

Accent Light: Press button to turn accent light on or off.

Auto: Press once to turn on Auto mode. Press again to turn off Auto function.

Speed/Sleep: By default, the machine will start running on low speed. Press the button once to run on medium speed, twice for high speed and a third time for sleep mode. Press button again to turn off sleep mode and return to low speed.

Timer: Press button to set timer. Press once for two hours, press twice for four hours and three times for 8 hours. Press through all options to not set a timer. Unit will automatically shut off after the set time runs out.

Filter Indicator: Press and hold the filter indicator button to reset the filter indicator light after cleaning or replacing your filters. The unit will beep 3 times to indicate reset.

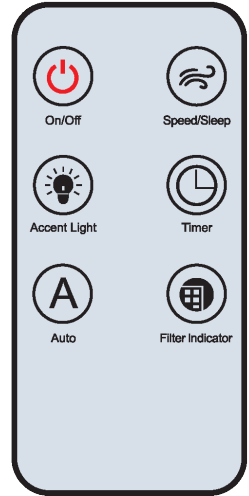

FIGURE 4

Remote Control

Replacing the Remote Battery:

It is recommended to replace the battery when the product takes a long time to respond or stops responding when the buttons are pressed.

1. Turn over remote control. Press the tab toward the right and pull.
2. Pull out battery holder and replace the battery. Only use the specified battery type (Lithium Button Cell Battery CR2025). The battery must be installed with the positive side facing up.
3. Insert battery holder back into remote.

Note: Do not apply excessive force to battery holder. Remove battery when not using for an extended period of time. When disposing of used battery, please use the correct method of disposal.

FIGURE 5

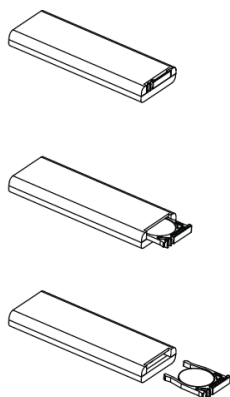

WARNING



Keep the lithium battery out of reach of small children.

Small children may accidentally swallow it.
If swallowed, call your doctor immediately.



Battery : Lithium Button Cell Battery (CR2025)

Filter Maintenance

We recommend periodically checking and cleaning filters for optimal performance. Under normal conditions of continuous use the pre-filter should be cleaned every 3 months (approximately 2,160 hours) and the HEPA filter should be cleaned every 6 months (approximately 4,320 hours). This estimate is only a guide. Depending on air quality and environmental factors, filters may need to be cleaned more regularly. To clean your filters, use a vacuum extension.

IMPORTANT: DO NOT use water, any liquid or detergents to clean the filters. Remove any packaging and plastic bag from the new filter before replacement.

Filter Replacement:

1. Power off and unplug the product.
2. Gently take off back grille.
3. Grab the tab to remove the filter from the compartment.
4. Remove the pre-filter from the HEPA filter.
5. Clean or replace both filters.
6. Align the pre-filter with the HEPA filter and firmly press to attach.
6. Put the filter back in the compartment.
7. Put the grille back into place and dispose of dirty filters.
8. Press and hold the filter indicator button to reset the filter indicator light. The unit will beep 3 times to indicate reset.

FIGURE 6

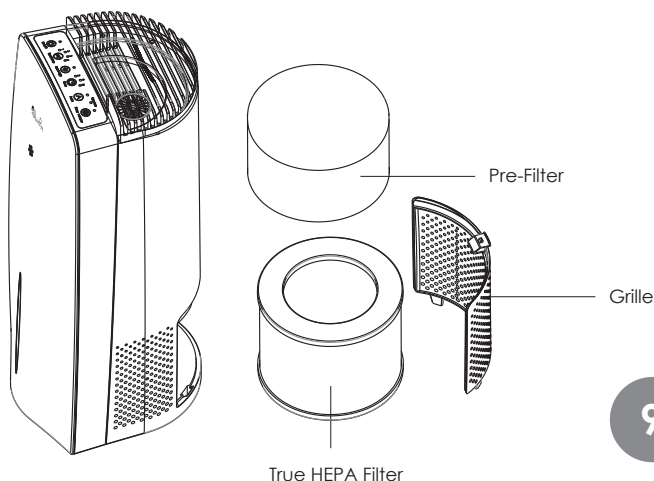

Cleanable Wick

We recommend periodically checking and cleaning your synthetic wick for optimal performance. Under normal water conditions of continuous use the wick should be cleaned every 1-3 months. This estimate is only a guide. Depending on your water quality and environmental factors, the wick may need to be cleaned more regularly.

IMPORTANT: DO NOT use any detergents to clean the wick.

Cleaning the Synthetic Wick:

1. Power off and unplug the product, ensure water tank is empty.
2. Remove the top cover from the unit.
3. Grab the handle inside the tank to remove the tank. Sit it on a sturdy surface.
4. Remove the wick from the tank. *WARNING: The wick may be saturated with water and drip when removed.*
5. Rinse the wick with water and vinegar.
6. Allow the wick to air dry before placing it back inside the tank.
7. Lift the tank by the handle to place back inside the unit.
8. Place top cover on the unit and resume use.

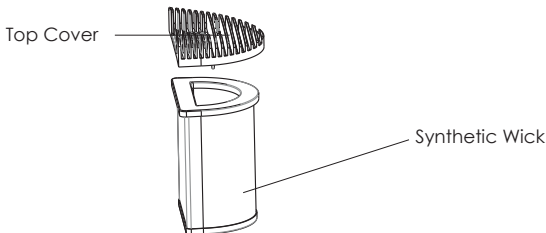
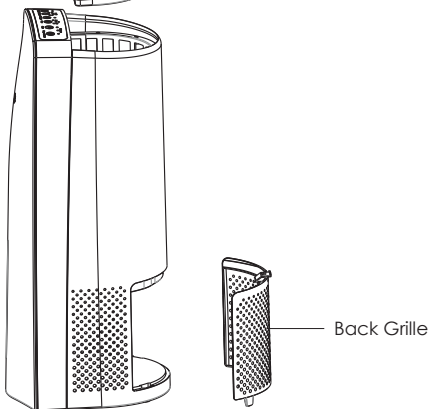

FIGURE 7



Maintenance

Note: ALWAYS unplug the product from electrical outlet before cleaning. **NEVER** allow water to sit in water tank when not in use.

Note: Hard water can cause calcium and magnesium to build up in a "white powder" on base of unit, transducer and inner surface of water tank. Overtime, this can cause humidifier to stop working properly. **Note:** It is recommended to clean the water tank daily, and clean the synthetic wick every 1-3 months, depending on water hardness. **Note:** Water tank should be emptied and cleaned before storage.

Daily Maintenance:

It is recommended to refill the water tank every day to avoid odor from sitting water and hard water build up.

1. Turn off product and unplug from wall outlet.
2. Remove top cover.
3. Grab handle and lift water tank out of the unit. Drain any water into a sink or tub. Shake water tank gently to remove any remaining water.
4. Rinse water tank thoroughly with water, empty, and wipe with a dry, soft cloth.
5. Wipe product base with a dry cloth if necessary.
6. Refill water tank as directed under *initial setup* and resume use.

Cleaning the Unit:

Hard water can cause calcium and magnesium to build up on base of unit in the form of white powder. Clean as often as needed.

1. Wipe off surface and base.
2. Rinse surface and base with clean water.

Troubleshooting

Problem: Excessive noise

Solution:

1. The water tank is not attached correctly. Properly insert water tank to base of unit.
2. The product is on an unstable surface. Place product on a sturdy, flat surface.

Problem: Product is not working properly

Solution:

1. The product is not connected to power. Plug product into a wall outlet and press the power button.
2. The water tank does not have enough water. Fill water tank with water. See *initial setup*.
3. The water tank has too much water. Remove excess water from tank.
4. Filter may be excessively dirty. Replace filter as needed.

Problem: Abnormal mist smell

Solution:

1. The unit is new. Remove tank cover and let water tank air out for 12 hours in a dry, cool space.
2. The water is dirty or has been sitting in unit too long. Clean water tank and add fresh, clean water. See *maintenance instructions*.

Problem: Not enough mist coming out

Solution:

1. There is too much calcium and magnesium build-up. Clean the synthetic wick and unit. See *maintenance instructions*.
2. Water is dirty or has been sitting in unit too long. Clean water tank and add fresh, clean water. See *initial setup*.

Filter/Wick Ordering

Replacement filters and wicks may be ordered online at www.livepureshop.com or by phone by calling LivePure Customer Support at (888) 855-5426. Applicable state and local taxes may apply. Prices are subject to change without notice.

Replacement Part Numbers:

Model Number	Filter Type	Part Number
LP460APH	Pre-Filter, 2-Pack	LP-PF460
LP460APH	True HEPA Filter	LP-HF460
LP460APH	Synthetic Wick	LP-SW460

Customer Support

If you need any assistance with setup, operation, or parts for your new LivePure Air Purifier/Humidifier, please call us. Our technical support staff is ready to help!

USA/Canada: 888-855-5426
Email: info@livepureshop.com

Hours of operation are from 8:00 AM to 6:00 PM EST.
You may also contact us online at:

www.livepureshop.com

Warranty

LivePure makes the following warranty to the original residential user or consumer purchaser of the air purifier/humidifier: If any part of the product fails during the first three (3) years from the date of purchase due to a defect in material or workmanship, we will provide a replacement part free of charge. If no replacement part can be provided, we will replace your product.

IF THE ORIGINAL RESIDENTIAL USER OR CONSUMER PURCHASER CEASES TO OWN THE AIR PURIFIER/HUMIDIFIER, THIS WARRANTY AND ANY IMPLIED WARRANTY WHICH THEN REMAINS IN EFFECT, INCLUDING BUT NOT LIMITED TO ANY IMPLIED WARRANTY OF MERCHANTABILITY OR FITNESS FOR A PARTICULAR PURPOSE, ARE VOIDED. THIS WARRANTY IS IN LIEU OF ALL OTHER EXPRESS WARRANTIES. THE DURATION OF ANY IMPLIED WARRANTY, INCLUDING BUT NOT LIMITED TO ANY IMPLIED WARRANTY OF MERCHANTABILITY OR FITNESS FOR A PARTICULAR PURPOSE IS EXPRESSLY LIMITED TO THE PERIOD OF THE EXPRESS WARRANTY SET FORTH ABOVE.

This warranty is voided if your air purifier/humidifier is not purchased and used in the USA or Canada. This warranty excludes and does not cover defects, malfunctions, or failures of the humidifier which were caused by repairs by persons not authorized by us, use of parts, or accessories not authorized by us, mishandling, modifications, or damage to the humidifier while in your possession, or unreasonable use, including failure to provide reasonable and necessary maintenance. This warranty does not cover products used in commercial applications. There are no express or implied warranties as to commercial purchasers or users.

Warranty

IN NO EVENT SHALL LIVEPURE COMPANY BE LIABLE FOR DIRECT, INDIRECT, SPECIAL, CONSEQUENTIAL OR INCIDENTAL DAMAGES IN EXCESS OF THE PURCHASE PRICE OF THE PRODUCT. YOUR SOLE REMEDY WILL BE REPAIR OR REPLACEMENT AS PROVIDED ABOVE. SOME AMERICAN STATES AND CANADIAN PROVINCES DO NOT ALLOW:

LIMITATIONS ON HOW LONG AN IMPLIED WARRANTY LASTS; THE EXCLUSION OR LIMITATION OF DIRECT, INDIRECT, SPECIAL, INCIDENTAL OR CONSEQUENTIAL DAMAGES; THE EXCLUSION OR INVALIDITY OF EXPRESS OR IMPLIED WARRANTIES IF THE USER CEASES TO OWN THE PRODUCT; THE LIMITATION OF THE REMEDIES AND RECOURSES AVAILABLE TO THE PURCHASER; OR THE INVALIDITY OF AN EXPRESS WARRANTY WHEN A PRODUCT IDENTIFIED BY BRAND NAME IS NOT USED (UNLESS SPECIFIC CONDITIONS ARE FULFILLED);

SO THE ABOVE LIMITATIONS OR EXCLUSIONS MAY NOT APPLY TO YOU. THIS WARRANTY GIVES YOU SPECIFIC LEGAL RIGHTS AND YOU MAY ALSO HAVE OTHER RIGHTS WHICH VARY FROM STATE TO STATE OR PROVINCE TO PROVINCE.