Read all instructions BEFORE assembly and USE of this product.
KEEP INSTRUCTIONS FOR FUTURE USE



The Mini Arc and The Euro Mini Arc

bassinets jumelés CO-SLEEPER^{MD}
de ARM'S REACH^{MD}

CO-SLEEPER[®] bassinets de ARM'S REACH[®]
como cama adosada

⚠ WARNING: Failure to follow these warnings and instructions could result in serious injury or death.

⚠ AVERTISSEMENT: Le non-respect de ces instructions et de ces avertissements peut causer des blessures graves, voire mortelles.

⚠ ADVERTENCIA: El incumplimiento de estas advertencias e instrucciones puede resultar en lesiones graves o la muerte.

INSTRUCTION MANUAL MANUEL D'INSTRUCTION MANUAL DE INSTRUCCIONES

KEEP THIS BOOKLET HANDY FOR FUTURE REFERENCE

GARDER CE LIVRET À PORTÉE DE MAIN POUR RÉFÉRENCE FUTURE

CONSERVE ESTE FOLLETO PARA REFERENCIA FUTURA

Read all instructions BEFORE assembly and USE of this product.

⚠ WARNING: Failure to follow these warnings and instructions could result in serious injury or death.

SUFFOCATION HAZARD: Discard all packing materials immediately after opening. Plastic bags and ties may cause suffocation or choking.

- **FALL HAZARD** - To help prevent falls, do not use this product when infant begins to push up on hands and knees or has reached manufacturer's recommended maximum weight of 18 lbs, whichever comes first.

SUFFOCATION HAZARD Infants have suffocated

- In gaps between extra padding and side of bassinet/cradle, and
- On soft bedding
- Use only the pad provided by manufacturer. Never add a pillow, comforter or another mattress for padding.

- If a sheet is used with the pad, use only the one provided by Arm's Reach®.
- To reduce the risk of SIDS, pediatricians recommend healthy infants be placed on their backs to sleep, unless otherwise advised by your physician.
- A bedside sleeper is designed to provide a sleeping area for an infant until he or she begins to push up on hands and knees or approximately 5 months of age. Move your child to another sleeping product when your child reaches this stage.
- **Entrapment Hazard**—To prevent death from entrapment, bedside sleeper must be properly secured to adult bed using the attachment system.
 - There must be no more than 1/2 in. (13 mm) gap between bedside sleeper and adult bed.
 - Check tightness before each use by pulling bedside sleeper in a direction away from adult bed.
 - If gap exceeds 1/2 in. (13 mm), DO NOT use product. Do not fill the gap with pillows, blankets or other items that are suffocation hazards.
- Always read and follow assembly instructions for each product use mode (bedside sleeper, bassinet, play yard).
- Always use ALL required parts for each use mode. Check instruction manual for a list of required parts. Periodically check product for loose, damaged, or missing parts.
- The anchor plate and straps assembly must always be used in bedside sleeper mode.

- Never use this product if there are any loose or missing fasteners, loose joints, broken parts, or torn mesh/fabric. Check before assembly and periodically during use. Contact Arm's Reach Concepts, Inc. for replacement parts. Never substitute parts.
- Assemble product according to manufacturer's instructions for ANY use mode—bedside sleeper as well as the bassinet.
- To avoid death from the infant's neck being caught on the top rail on the side that is next to the adult bed, the top rail must be no higher than the adult bed mattress.
- Never permit bedding from the adult bed to extend into the Bedside Sleeper
- NEVER LEAVE your infant unattended in the Arm's Reach® Co-Sleeper® bedside bassinet.
- Strings can cause strangulation! Never place items with a string around a child's neck such as hood strings or pacifier cords. DO NOT suspend strings over the unit in any configuration or attach string to toys.
- NEVER LEAVE infant in product without the TOP HORIZONTAL RAIL installed in the upper most position, unless securely attached to the adult bed.
- Always check to be sure that the upper locking bars and the lower locking bars are in their "locked position" before placing the infant in the Arm's Reach® Co-Sleeper® bedside bassinet.
- NEVER USE more than 4-2" (5CM) leg extension segments with the Arm's Reach® Co-Sleeper® bedside bassinet.
- ONLY use leg extensions on the Co-Sleeper® bedside bassinet when it is attached to the parental bed.
- NEVER use plastic shipping bags or other plastic film as mattress covers not sold and intended for that purpose. They can cause suffocation.
- Make sure all straps are secured and tight when used in the co-sleeping position. Tighten straps periodically.
- **STRANGULATION/SUFFOCATION HAZARD:** The top edge of the lowering bar must be level with or below the top of the adult mattress when used as an Arm's Reach® Co-Sleeper®. The level of the Arm's Reach® Co-Sleeper® bedside bassinet mattress must be a minimum of 4 inches below the top edge of the lowering bar. **NEVER raise the level of the Arm's Reach® Co-Sleeper® bedside bassinet mattress.**
- NEVER USE the Arm's Reach® Co-Sleeper® bedside bassinet in Co-Sleeper position without the anchor plate attached and locked as shown. Failure to use this anchoring system could result in serious injury or death to the infant. Make sure all straps are secured and tight. Check straps before each use.
- Failure to use this securing system will allow the Arm's Reach® Co-Sleeper® bedside bassinet to move away from the adult bed and could result in the infant falling out of the Co-Sleeper® bedside bassinet.

Read all instructions BEFORE assembly and USE of this product. _____

- **STRANGULATION HAZARD:** When anchor plate and strap assembly are not in use, store in a safe place not accessible to children.
- **DO NOT** place product near a window where cords from blinds or drapes may strangle a child.
- Keep the bassinet away from stoves, heaters, campfires and other hazards.
- **DO NOT** allow children to climb or play on or under unit in any configuration.
- **FALL HAZARD:** Remove infant from the Arm's Reach® Co-Sleeper® bedside bassinet before starting any conversions.
- Always make sure all top and bottom rails are securely locked, in all configurations, before putting an infant /child into the unit.
- **⚠ WARNING** – To prevent serious or fatal injury from falls always keep child within arm's reach. Never leave your child unattended.

Parts List

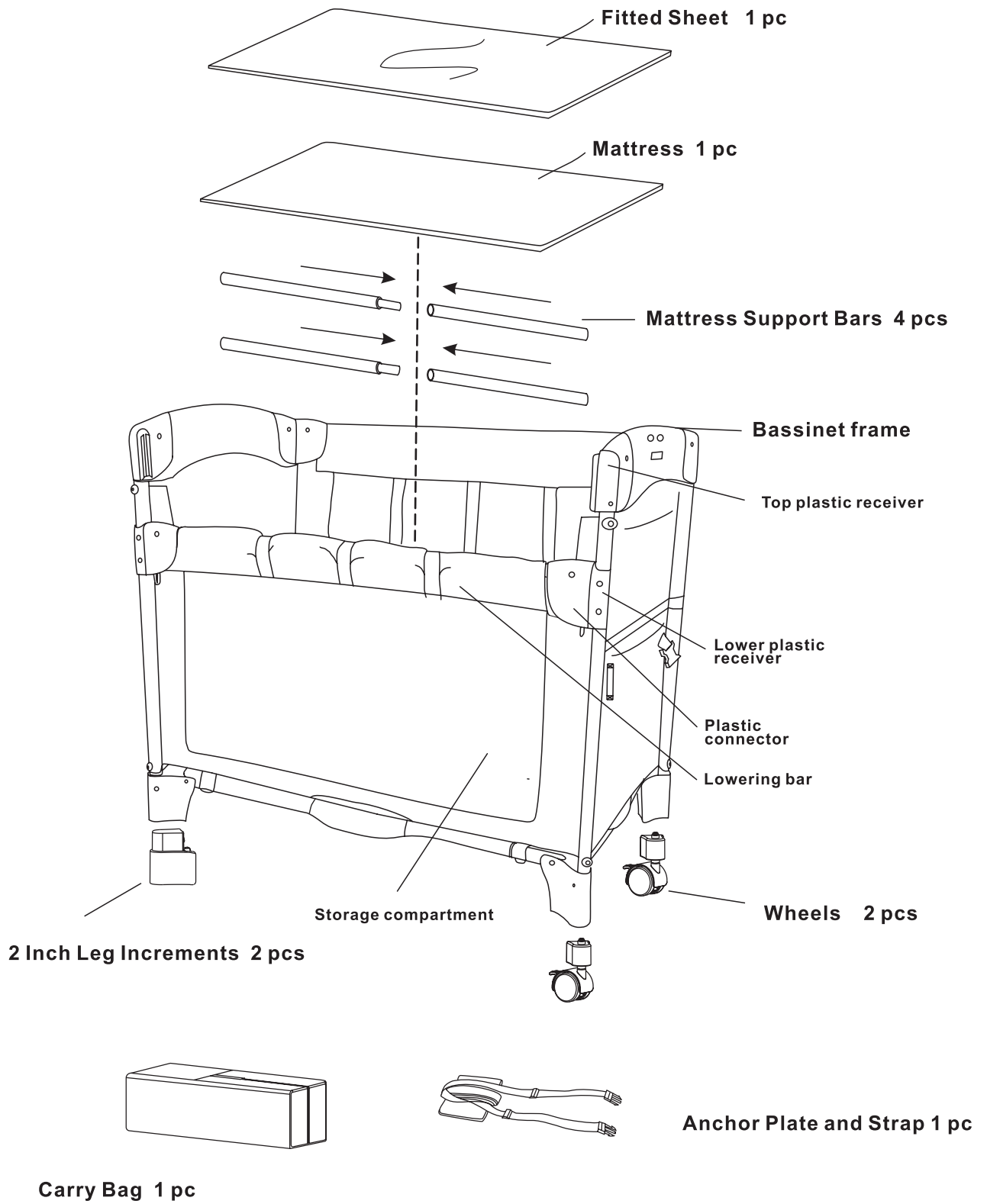

How to set up the Arm's Reach® Co-Sleeper® bedside bassinet

⚠ WARNING: Failure to follow these warnings and instructions could result in serious injury or death.

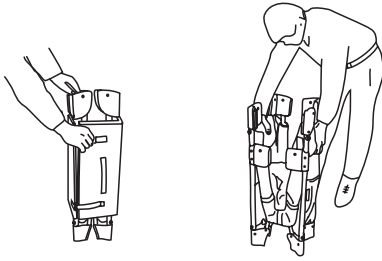

Step 1

Unzip the carry bag and remove the Arm's Reach® Co-Sleeper® bedside bassinet.
Undo the Velcro® straps.
Set mattress aside.

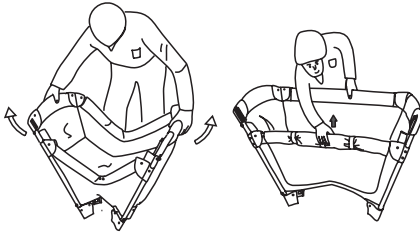

Step 2

Stand up the folded Arm's Reach® Co-Sleeper® bedside bassinet and separate the four top corners.

Lock the top bars by pulling up on the center of each bar.

Note- there are two locking mechanisms on each top bar. Sometimes you need to pull it up quickly to get both mechanisms to lock securely.

Do this for all 4 top bars. They should all be rigid when they are all locked.

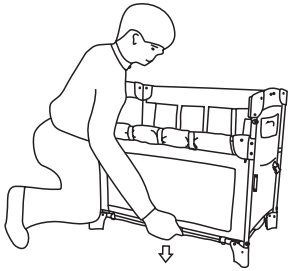

Step 3

Lock bottom bars by pushing down on the center of each bottom bar. You can do this with your hand or foot. Make sure all bottom bars are rigid.

NOTE- DO NOT LOCK BOTTOM BAR UNTIL TOP BAR IS LOCKED AND RIGID.

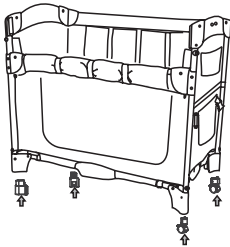

Step 4

Install the wheels and leg increments as figure shown.

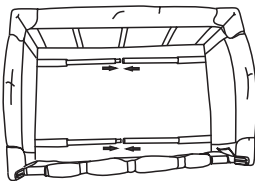

Step 5

Install two Mattress Support Bars into fabric tunnels on the nest floor as shown in figure. Put sheet on mattress and put mattress in the sleeping nest. You will notice the sheet has Velcro® strips, this will attach to the Velcro® strips in the sleeping nest. Make sure the Velcro® strips on the mattress and sheet attached to the Velcro® in the sleeping nest bottom.

It is in Co-Sleeping position now. Go to page 8 to attach the bedside bassinet to adult bed.

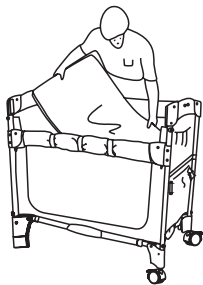

⚠ WARNING: SUFFOCATION HAZARD - To help prevent suffocation and entrapment, use ONLY the mattress pad provided by Arm's Reach® Concepts, Inc. NEVER use additional padding or mattress. DO NOT use shipping or other bags as mattress covers since they can cause suffocation.

How to set up the free-standing bassinet

⚠️ FALLING HAZARD: Remove infant from the Arm's Reach[®] Co-Sleeper[®] bedside bassinet before starting any conversions.

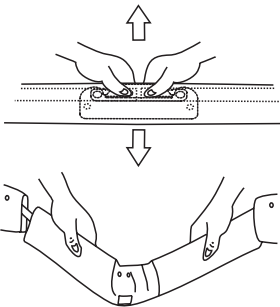
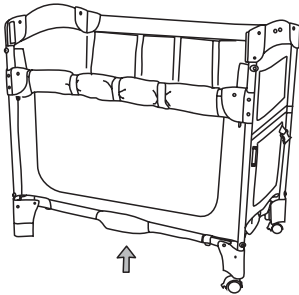

Step 1

Unlock bottom bar of the lowering bar side by pulling up on the center of the bottom bar or using your foot, lift up in the center of the bottom bar until it becomes an inverted "V" shape. Release the 3 Velcro[®] straps that go over the bar to open the pockets on inside of front unit, then release the 3 straps with buckle.

NOTE- YOU MUST UNLOCK BOTTOM BAR BEFORE UNLOCKING THE TOP BAR.

Step 2

Unlock top lowering bar by placing your thumbs on the two buttons indicated on the bar until the bar releases into a "U" shape position.

Note- Push buttons in while lifting up slightly on bar and then pushing bar down into a "U" shape position.

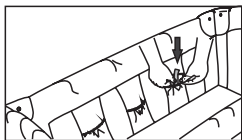
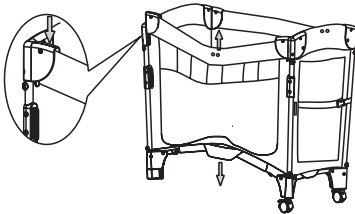
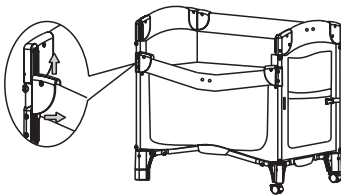

Step 3

Find the locking tab under the plastic connector pieces. Push towards the center of the bar and pull up on the connector piece at the same time. Do this on both sides. Put the connector pieces in the top receivers and slide into place. Pull up on the top bar to lock. Make sure the bar is rigid. Then push down on the bottom bar to lock in position. **DO NOT lock bottom bar until top bar is locked and rigid.** Keep the Velcro[®] tabs to the pockets inside the nest wall and put the 3 straps with male buckles into the pockets outside the nest wall.

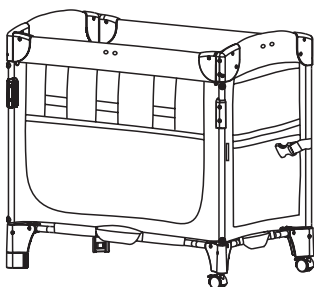

When the horizontal rail is secured in the top position, use as free-standing bassinet.

How to convert to the co-sleeping position from the free-standing bassinet

⚠ FALLING HAZARD: Remove infant from the Arm's Reach[®] Co-Sleeper[®] bedside bassinet before starting any conversions.

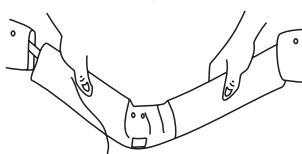
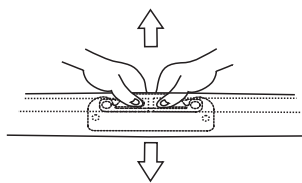
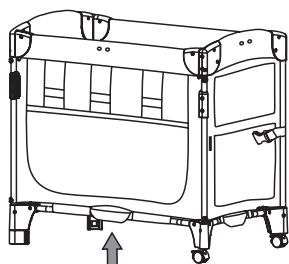

Step 1

Unlock bottom bar of the lowering bar side by pulling up on the center of the bottom bar or using your foot, lift up in the center of the bottom bar until it becomes an inverted "V" shape.

Step 2

Unlock top lowering bar by placing your thumbs on the two buttons indicated on the bar until the bar release into a "U" shape position. **Note- push buttons in while lifting up slightly on bar, and then push bar down into a "U" shape position. You must unlock the bottom bar before unlocking the top bar**

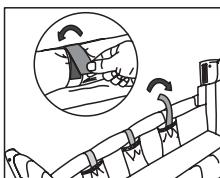
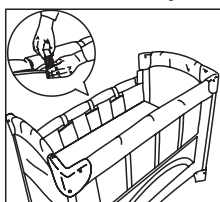
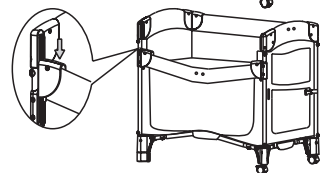
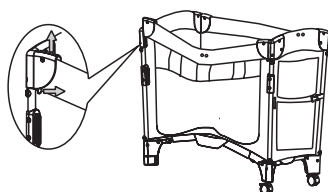

Step 3

Find the locking tab under the plastic connector pieces. Push towards the center of the bar and pull up on the connector piece at the same time. Do this on both sides. Put the connector pieces in the lowest receiver and slide into place. Take out the three straps with male buckles from front three pockets. Secure buckles to inside pocket.

Step 4

Pull up on the center of top bar to lock. Make sure the bar is rigid. Close inside pockets openings by securing Velcro[®] tabs over straps. Push down on the bottom bar to lock into position. It is now in Co-Sleeping position.

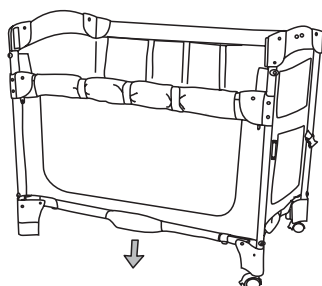

⚠ WARNING: SUFFOCATION/ENTRAPMENT HAZARD
This step prevents lining from loosening inside sleeping area at front side of mattress.

How to attach the Arm's Reach® Co-Sleeper® bedside bassinet to adult bed

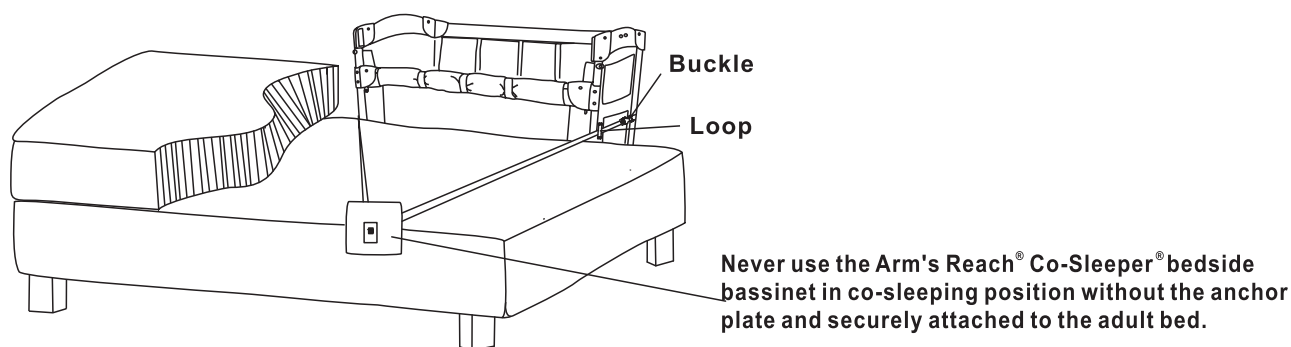

The top edge of the LOWERING BAR when used in co-sleeping position must be level with or below the top of adult mattress.

Mini ARC

Measure adult bed from floor to top of mattress. If measurement is more than 24" a leg extension kit will be needed to ensure proper height and maintain safety. 1 Leg Extension Kit will raise the Co-Sleeper® up to 6 additional inches in 2" increments accommodating beds 26", 28" and 30". NEVER use more than 1 extension kit.

Euro Mini ARC

The top edge of the LOWERING BAR when used in the co-sleeping position measures 18 inches when using the wheels and leg increments, and 16" without wheels and leg increments. Measure adult bed from floor to top of mattress. If measurement is more than 18" a leg extension kit will be needed to ensure proper height and maintain safety. 1 leg extension kit will raise the Co-Sleeper up to 6 additional 6 additional inches in 2" increments accommodating beds 20", 22" and 24". NEVER use more than 1 extension kit.

Unroll nylon straps from the anchor plate and lay straps across the adult bed to line up with the center of the desired position of your Co-Sleeper® bedside bassinet. The straps must now be positioned between upper and lower mattress or box spring.

Slide the straps between both mattresses using a back and forth "sawing" motion and at the same time pulling downward until the straps and anchor plate are at the desired position. One strap should come out on each side of the Co-Sleeper® bedside bassinet. Pass through "belt loop" found at front leg of Co-Sleeper® bedside bassinet.

Connect into the female buckle at the rear leg of Co-Sleeper® bedside bassinet.

Tighten Co-Sleeper® bedside bassinet against adult bed by pulling on excess strap. Take excess strap and pass it back through "belt loop" and push it between adult mattress. Repeat on other side

Mattress, Boxsprings & Frame aligned

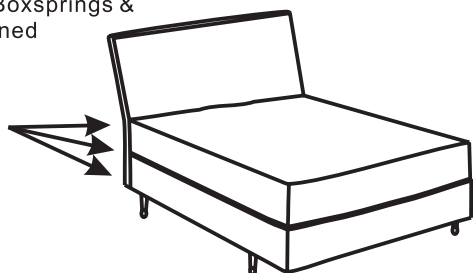

ACCEPTABLE BED FRAME IN-LINE

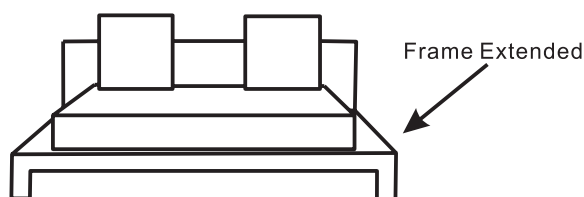



UNACCEPTABLE BED, MATTRESS, BOXSPRING & FRAME NOT IN-LINE

 **WARNING:** STRANGULATION/SUFFOCATION HAZARD: The top edge of the lowering bar must be level with or below the top of the adult mattress when used as a Co-Sleeper[®] bedside bassinet. The level of the Co-Sleeper[®] bedside bassinet mattress must be a minimum of 4 inches below the top edge of the lowering bar. NEVER raise the level of the Co-Sleeper[®] bedside bassinet mattress level with, or above the top of the lowering bar.

 **WARNING:** NEVER USE as a Co-Sleeper[®] bedside bassinet without the anchor plate attached and locked as shown. Failure to use this anchoring system could result in serious injury or death to the infant. Make sure all straps are secured and tight. Check straps before each use.

 **WARNING:** Failure to use this securing system will allow the Co-Sleeper[®] to move away from the adult bed and could result in infant falling out of the Co-Sleeper[®] bedside bassinet. NEVER leave infant unattended in the Co-Sleeper[®] bedside bassinet.

 **WARNING :** STRANGULATION/ CHOKING HAZARD DO not allow excess strap (or any other loose object) to find it's way into the Co-Sleeper[®] bedside bassinet. Do Not allow excess strap to lay loose on floor because someone may trip over it.

 **WARNING:** Make sure all Velcro[®] straps are secured and tight when used in the Co-Sleeper[®] bedside bassinet position. Tighten straps periodically.

How to fold the Arm's Reach® Co-Sleeper® bedside bassinet

⚠ STRANGULATION HAZARD: When anchor plate and strap assembly are not in use, store in a safe place not accessible to children.

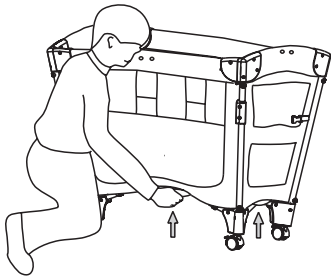

Step 1

Remove mattress support bars and mattress, and set aside. Unlock all the bottom bars by using your hand or foot by reaching down and pulling up on the center of each bottom bar. The bottom bars will form an inverted "V" shape.

NOTE- BOTTOM BAR MUST FIRST BE UNLOCKED BEFORE ATTEMPTING TO UNLOCK THE TOP BAR.

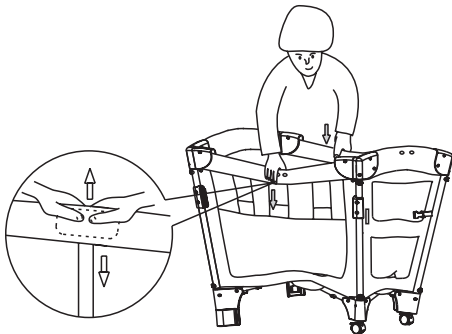

Step 2

Unlock top bars by placing your thumbs on the two buttons indicated on the bar until the bar releases into a "U" shape position. Do this for all the top bars.

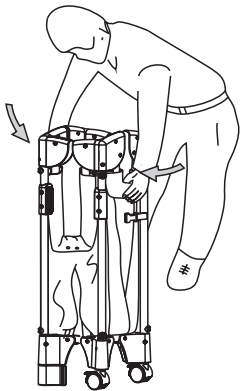

Step 3

Gather together. It should collapse down into a rectangular position. If the legs are sticking up, lay the Arm's Reach® Co-Sleeper® bedside bassinet on its side and push the leg towards floor.

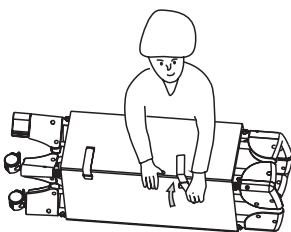

Step 4

Take sheet off of the mattress and wrap the mattress around the unit. There are Velcro® straps that feed through plastic loops attached to the other side of the mattress. Pull taut. Store the sheet in the end of the unit.

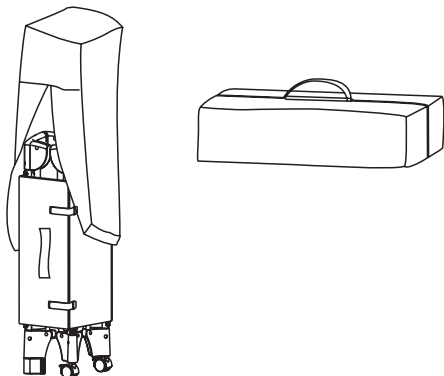

Step 5

Put into carry bag with the handle from the mattress coming through the opening in the bag.

Maintaining your Arm's Reach® Co-sleeper® bedside bassinet

Spot clean with soft clean damp cloth.

Laundering fitted sheet:

Machine wash on lukewarm setting and drip-dry.

NO BLEACH.

Trouble shooting

- Q. *"I am having trouble getting the upper bar to unlock. The buttons are hard to push in".*
- A.
1. Unlock the bottom bars at four sides.
 2. Locate the two buttons directly behind the "PRESS TO UNLOCK" words on the fabric sleeve that cover the upper locking bars. (see A)
 3. Gently push in on each button as you lift and lower the locking mechanism with a short up and down motion. (see B) By doing this, the locking buttons will "find" their way into the alignment holes and the upper bar will be unlocked and fold downward. (See C)

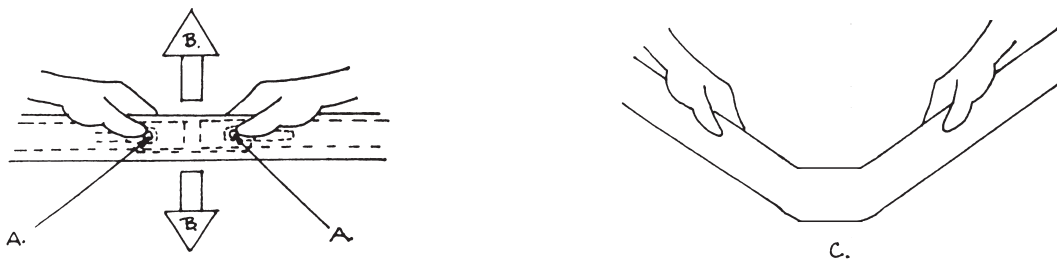

4. Make sure that both bars (right and left) are unlocked to form a 'U' shape. If one side is longer than the other, then you have not unlocked both bars and the unit will not fold up properly.

- Q. *"I have all my bars unlocked and I'm having trouble folding up my Co-Sleeper®."*
- A.
1. If all upper bars are all formed into a "U" shape lay Co-Sleeper® on its side. Two legs will be on the floor and two legs in the air. With the two legs in the air put slight force pushing down towards floor.
 2. Fold the unit together so that the upper four plastic corners are touching each other to form a neat square.

If you have any question or need further assistance, please call (800)954-9353
For more troubleshooting visit our website at www.armsreach.com

Important assembly instruction

(A) Unlocking Top Bars

Always UNLOCK all bottom bars forming an inverted "V" shape. Then on the top bar locating the two buttons and push them in while slightly lifting up and push down to form a "U" shape.

(B) Converting to Co-Sleeping Mode

Follow "Unlocking Top Bars" instruction in (A), open Velcro® tab under plastic corner. Pull tab on plastic receiver and lift up sliding plastic receiver then place on lower position and lock bar. Lastly lock bottom bar.



Sleep better • Sleep closer • Sleep safer™

If you have any questions- call or write Arm's Reach Concepts, Inc.
2081 N Oxnard Blvd.,PMB#187, CA 93036-2964
(800) 954-9353 fax: 805-604-7982 www.armsreach.com
Hours: 9:00 A.M. 4:00 P.M. Pacific Time

Si vous avez des questions, appelez ou écrivez à Arm's Reach Concepts, Inc.
2081 N Oxnard Blvd., PMB#187, CA 93036-2964
(800) 954-9353 Fax : 805-604-7982 www.armsreach.com
Heures : 9 h 00 à 16 h 00 (heure du Pacifique)

Si tiene preguntas, no vacile en llamar o escribir a Arm's Reach Concepts, Inc.
2081 N Oxnard Blvd., PMB#187, CA 93036-2964
(800) 954-9353 fax: 805-604-7982 www.armsreach.com
Horario: 9:00 a.m. - 4:00 p.m. Horario del Pacífico

©2014 ARMS REACH CONCEPTS INC. ARMS REACH, CO-SLEEPER, Mother & Child Logo and all other trademarks are rigorously protected. All rights reserved. Patented and patent pending. Meet ASTM F2194, ASTM F2906 requirements. ARC 2-2014

©2014 ARMS REACH CONCEPTS INC. ARMS REACH, CO-SLEEPER, le logo de la mère avec l'enfant et toutes les autres marques de commerce sont rigoureusement protégés. Tous droits réservés. Breveté et brevet en instance. Répondre aux normes ASTM F2914, F2906 exigences. ARC 2-2014

©2014 ARMS REACH CONCEPTS INC. ARMS REACH, CO-SLEEPER, el logotipo de la madre e hijo y todas las otras marcas comerciales están rigurosamente protegidos. Todos los derechos reservados. Patentada y pendiente de patente. Conocé ASTM F2914, F2906 requisitos. ARC 2-2014