

LINEAR DENSITY ±5%Kg/m	AREA 15.67 mm ²	WEIGHT ±5%Kg/pcs	VOLUME cm ³	SCALE 1 : 1	REV. 0	SECTION NO.
---------------------------	-------------------------------	---------------------	---------------------------	----------------	-----------	-------------

SCALE 1:1

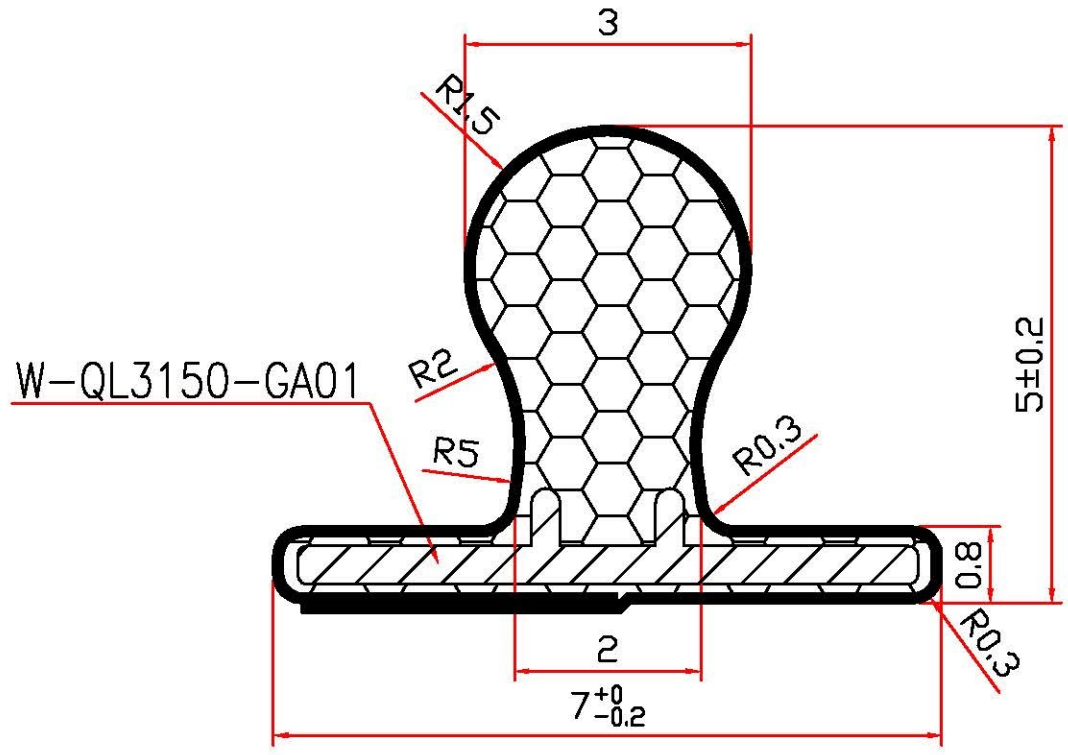

SIZE TOLERANCE	
RANGE	TOLERANCE
0-1.5	±0.15
1.5-2.5	±0.20
2.5-4.0	±0.25
4.0-6.3	±0.35
6.3-10	±0.40
10-16	±0.50
16-25	±0.70
25-40	±0.80
40-63	±1.00
63-100	±1.30
ABOVE 100	±1.50

UNSPECIFIED CORNERS --- mm RAD.
UNSPECIFIED THICKNESS --- mm

SECTION NO. PQ70500
MATERIAL PEVA+PP+PU
HARDNESS

DRAWN
DATE 2015/04/03
APPROVED
CHECKED

