

WEIGHT	AREA	OUT PERIM.	VOLUME	SCALE	REV.	SECTION NO.
Kg/m	26.15 mm <sup>2</sup>	mm	cm <sup>3</sup>	1 : 1	0	

SCALE 1:1

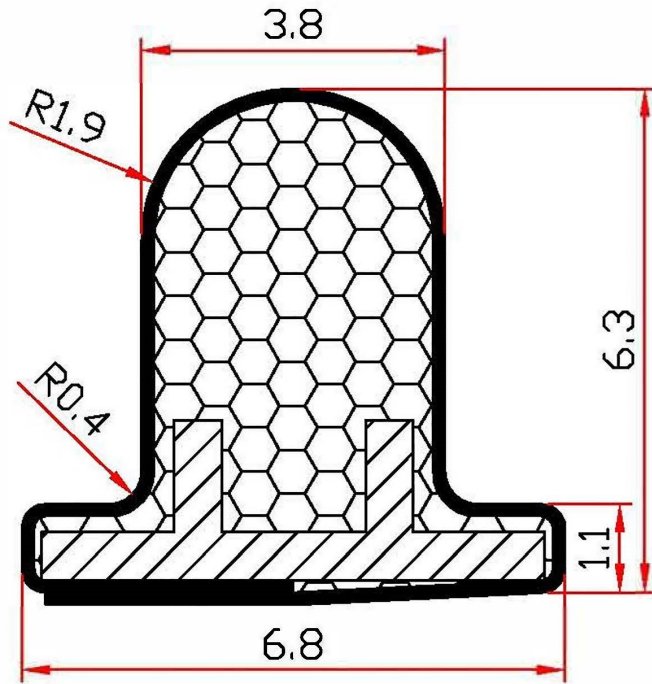
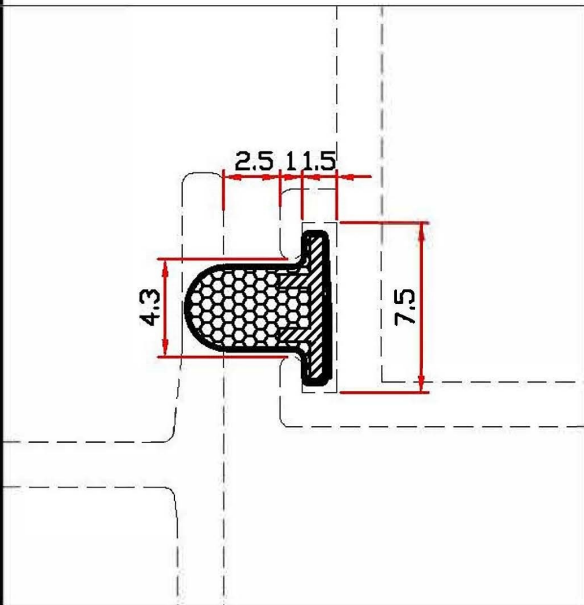

SIZE TOLERANCE	
RANGE	TOLERANCE
0-1.5	±0.15
1.5-2.5	±0.20
2.5-4.0	±0.25
4.0-6.3	±0.35
6.3-10	±0.40
10-16	±0.50
16-25	±0.70
25-40	±0.80
40-63	±1.00
63-100	±1.30
ABOVE 100	±1.50

UNSPECIFIED CORNERS --- mm RAD.  
UNSPECIFIED THICKNESS --- mm

SECTION NO. PQ69650
MATERIAL PU Sponge
HARDNESS

DRAWN
DATE 2012/05/25
APPROVED
CHECKED

