

# INSTRUCTIONS FOR USE

TANDYPRO® MACHINES  
HEAT IMPRINTER  
3980-01

tandyPro®  
MACHINES

1. Loosen both set screws on the bracket.
2. Push handle down to lift heating body.
3. Tighten both set screws.
4. Install either letters or makers mark into the letter holder.
5. Slide the letter holder into the t-channel.
6. Turn machine on.
7. Set the temperature (see chart on next page).
8. Allow the machine to heat up, depending on what is in the letter holder you may need to wait an extra few minutes after elements have heated for the imprinting face to be hot enough.
9. If using foil, place the foil on the leather under the imprinting surface with shiny side facing up.
10. Press and hold the imprinting surface in contact with the material for the amount of time specified on the chart below.
11. Lift the imprinting surface from the material and remove the material from the machine.
12. Pull the foil off the material.

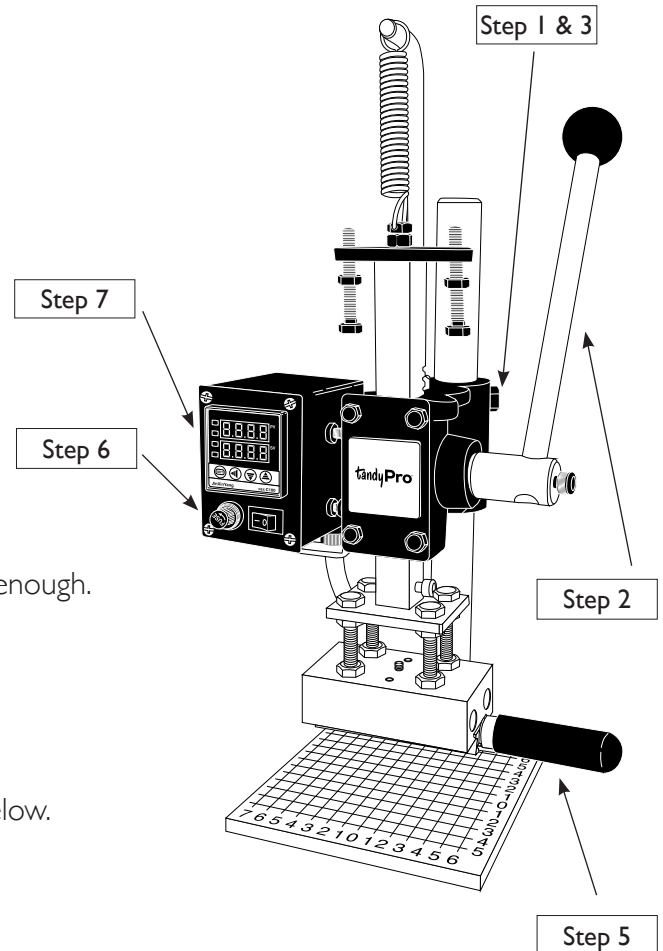

**WARNING:** Heated equipment surfaces can become very hot during operation and can cause severe burns. Do not touch heated equipment while operating or just after stopping; wait until equipment has cooled completely. This product is not intended for use by children; adult supervision required.

**WARNING:** Choking hazard; small parts. Not for children under 3 years.

# TANDYPRO® MACHINES HEAT IMPRINTER



## TEMPERATURE CHART

MATERIAL	GILDING	IMPRINTING
Paper	110°c for 1/10 second	350°c for 1/3 second
Leather	110°c for 1/10 second	150°c for 1/3 second
Polyurethane	110°c for 1/10 second	150°c for 1/3 second
PVC	110°c for 1/10 second	120°c for 1/3 second
Wood	110°c for 1/10 second	350°c for 1/3 second

## WARRANTY INFORMATION

Manufacturer warrants this product to be free from defects in workmanship and materials, under normal use and conditions, for a period of 6-months from the purchase date.

To request repair or damage support, please e-mail [tlfhelp@tandyleather.com](mailto:tlfhelp@tandyleather.com) and include the following information:

- 1) CUSTOMER ID/ORDER ID/DATE OF PURCHASE
- 2) MACHINE SERIAL #
- 3) PICTURES/VIDEO OF THE DEFECT
- 4) ADDITIONAL NOTES DESCRIBING THE ISSUE

Customer Service: 877-LEATHER  
[www.tandyleather.com](http://www.tandyleather.com)