

LIMITED LIFETIME WARRANTY

THANK YOU FOR CHOOSING THE COBRA LEATHER STITCHING MACHINERY, OR COBRA MACHINERY FOR LEATHER. THIS WARRANTY IS FOR THE ORIGINAL PURCHASE ONLY.

ANY MACHINERY WITH A FACTORY DEFECT WILL BE REPLACED OR REPAIRED FREE OF CHARGE. LEATHER MACHINE CO., INC. WILL MAKE THIS DETERMINATION.

DURING THE FIRST YEAR, ALL SHIPPING WILL BE PAID BY LEATHER MACHINE CO., INC.

CASTINGS, SHAFTS, BUSHINGS, BEARINGS, CONNECTING RODS, LINKAGE, HANDWHEEL, CAMS, OR ANY INTERNAL PARTS ARE COVERED WITH THIS WARRANTY, EXCEPT WHAT MAY BE LISTED BELOW.

NEEDLES, BOBBINS, PLATES, FEED DOGS, FEET, BELTS, BULBS, SPRINGS, GUIDES, SHUTTLE HOOKS, BOBBIN CASES, TENSION ASSEMBLIES, SCREWS, NUTS, LAMPS, THREAD STANDS, SPEED REDUCERS, KNIVES AND BLADES ARE NOT COVERED IN THIS WARRANTY.

LEATHER MACHINE CO., INC. WILL NOT BE RESPONSIBLE FOR ABUSE, NEGLIGENCE, NORMAL WEAR AND TEAR, ACCIDENTS, OR NATURAL DISASTERS.

ALL MOTORS COME WITH A 3 YEAR WARRANTY.

THANK YOU,

LEATHER MACHINE COMPANY INC.

2141 E. PHILADELPHIA ST. "U" ONTARIO, CA. 91761

PHONE: (866) 962-9880 EMAIL: COBRA@LEATHERMACHINECO.COM

WWW.LEATHERMACHINECO.COM

LEATHER MACHINE COMPANY INC.

INSTRUCTION & PARTS MANUAL:

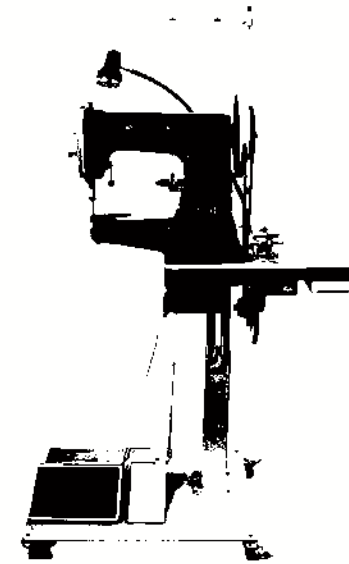

COBRA CLASS 3

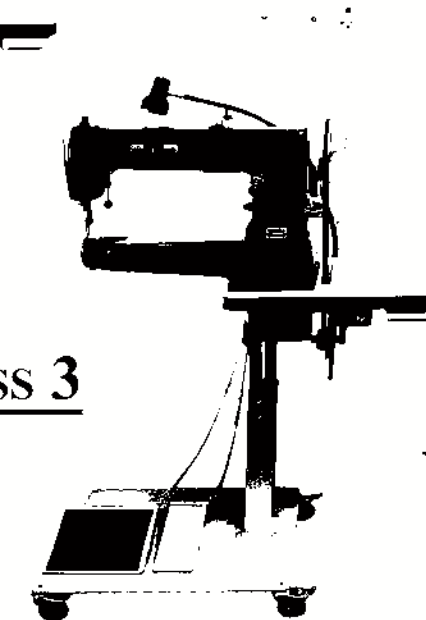

COBRA CLASS 4

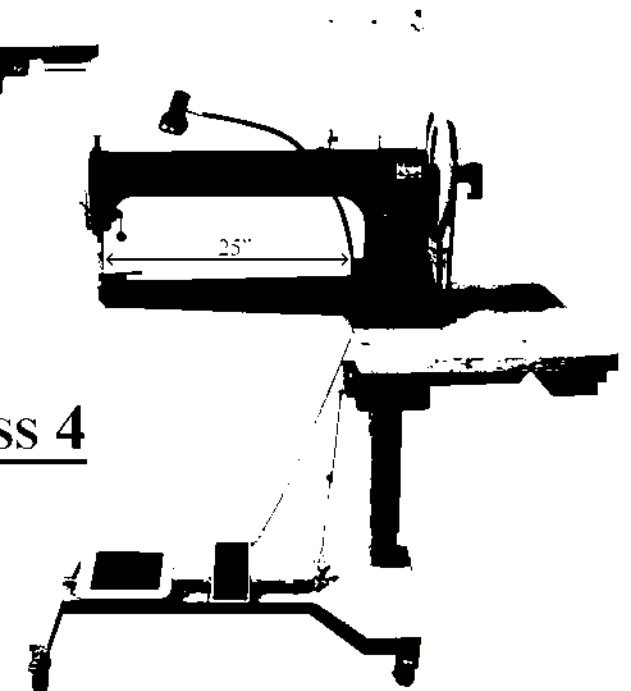

KING COBRA

TABLE OF CONTENTS

IMPORTANT INFORMATION.....	2
MACHINE TERMINOLOGY.....	3
INSTALLING THE HANDWHEEL, THREAD RACK, THROAT PLATE ALIGNMENT....	4
INSTALLING THE BOBBIN.....	5
INSTALLING THE NEEDLE.....	6
WINDING A BOBBIN ON COBRA CLASS 3.....	7
WINDING A BOBBIN ON COBRA CLASS 4.....	8
THREADING THE MACHINE, STITCH LENGTH, SEWING IN REVERSE.....	9
SEWING TIPS AND SERVICE TIPS.....	10
ADJUSTING THE PRESSER FOOT PRESSURE, THREAD TENSION.....	11
ADJUSTING THE HEIGHT OF THE FEED DOG, REMOVING THE FEED DOG.....	12
CLEANING THE SHUTTLE HOOK AREA, TIMING THE SHUTTLE HOOK.....	13
SHUTTLE HOOK COMPONENTS.....	14
SHUTTLE HOOK PART NUMBERS.....	15
MAINTENANCE TIPS.....	16
NEEDLE AND THREAD REFERENCE GUIDE.....	20
MOTOR INSTRUCTIONS.....	21
ACCESSORY INSTRUCTIONS.....	22

IMPORTANT NOTICE

YOUR COBRA HAS BEEN PRE-SET AT OUR FACILITY AND IS READY TO SEW.

PLEASE DO NOT MAKE ANY TIMING ADJUSTMENTS.

IF YOU DO REQUIRE OUR ASSISTANCE AT ANY TIME,

PLEASE CALL US AT:

866-962-9880

ACCESSORY INSTRUCTIONS

HOLSTER PLATE: THE HOLSTER PLATE IS USED WHEN MAKING ANY HOLSTERS OR OTHER ITEMS THAT REQUIRE A CLIP, OR SOME OTHER TYPE OF CONNECTOR THAT WILL IMPEDE THE FEEDING OF THE HOLSTER. YOU MUST REMOVE THE REGULAR PLATE AND THE FEED DOG, THEN PUT THE HOLSTER PLATE ON. YOU MUST ALSO USE THE RIGHT TOE PRESSER FOOT. THE HOLSTER PLATE RAISES THE HOLSTER SO WHEN SEWING, IT WILL CLEAR THE CASTING. YOU MUST INCREASE THE STITCH LENGTH AS WELL.

STIRRUP PLATE: THE STIRRUP PLATE IS USED WHEN SEWING STIRRUPS, GUSSETS, OR WHEN SEWING CASES WHERE THE CORNERS ARE STIFF. YOU MUST REMOVE THE REGULAR PLATE AND THE FEED DOG, THEN PUT ON THE STIRRUP PLATE. YOU MUST ALSO USE THE RIGHT TOE PRESSER FOOT. THE STIRRUP PLATE RAISES THE STIRRUP SO WHEN SEWING, IT WILL CLEAR THE CASTING. YOU MUST INCREASE THE STITCH LENGTH AS WELL.

SLOTTED PLATE: THE SLOTTED PLATE IS USED WHEN SEWING ALL TYPES OF STRAPPED GOODS, OR LIGHT LEATHER. YOU MUST REMOVE THE REGULAR PLATE AND THE FEED DOG, THEN PUT ON THE SLOTTED PLATE. THE SLOTTED PLATE IS ALSO USED FOR TOP STITCHING AND IS MOSTLY USED WITH THE ROLLER EDGE GUIDE. WHEN TOP STITCHING, USE THE LEFT TOE FOOT AND THE DOUBLE TOE FOOT FOR LIGHT WEIGHT LEATHER. YOU MUST INCREASE THE STITCH LENGTH AS WELL.

LEFT TOE PRESSER FOOT: THIS IS THE STANDARD FOOT FOR GENERAL SEWING.

RIGHT TOE PRESSER FOOT: THE RIGHT TOE PRESSER FOOT IS USED WHEN SEWING NEXT TO WELTS, CORDS, AND ZIPPERS. THE RIGHT TOE PRESSER FOOT IS ALSO USED WHEN USING THE HOLSTER OR STIRRUP PLATE.

DOUBLE TOE PRESSER FOOT: THE DOUBLE TOE PRESSER FOOT IS USED WHEN SEWING UP TO BUCKLES, D-RINGS, SPOTS, AND CONCHOS YOU CAN ALSO USE IT FOR SEWING LIGHT LEATHER WHERE THE DOUBLE TOES HOLD DOWN THE LEATHER ON BOTH SIDES OF THE CENTER FOOT.

BLANKET SET: THE BLANKET SET IS USED WHEN SEWING ANYTHING OTHER THAN LEATHER, LIKE BLANKETS, PADS, CANVAS, NYLON WEBBING, BIO PLASTICS, UPHOLSTERY, AND OTHER SUCH MATERIALS. YOU MUST CHANGE THE FEED DOG. WHEN SEWING ½" INCH THICK MATERIAL, CHANGE THE PRESSER FEET AS WELL.

ROLLER EDGE GUIDE: THE ROLLER EDGE GUIDE IS FOR SEWING STRAIGHT OR WHEN YOU TOP STITCH. YOU MUST REMOVE THE BLACK PLATE, NEXT TO THE NEEDLE PLATE, THEN ATTACH THE ROLLER EDGE GUIDE TO THE MACHINE. IT ADJUSTS FOR DIFFERENT ALLOWANCES.

MOTOR INSTRUCTIONS

TO ADJUST SPEED

- 1- HOLD THE DOWN BUTTON ON THE CONTROL PANNEL UNTIL THE DISPLAY READS 'S.3' (THE 'S' WILL LOOK LIKE A '5')
- 2- PRESS THE UP BUTTON 3 TIMES UNTIL THE DISPLAY READS 'S.3'
- 3- PRESS THE DOWN BUTTON ONE TIME
- 4- AFTER #3 ABOVE – TO INCREASE SPEED PULSE THE BUTTON UP AS MANY TIMES AS YOU WANT – THE NUMBER ON THE DISPLAY WILL INCREASE 1 NUMBER PER PULSE. THE NUMBER YOU SEE IS THE RPM OF THE TOP SPEED OF THE MOTOR. FOR EXAMPLE, THE NUMBER 12 Is 1200 RPM, 13 IS 1300 RPM, ETC.
- 5- ONE YOU HAVE SET THE MOTOR TO THE TOP SPEED YOU WANT, WAIT 5 SECONDS FOR THE DISPLAY TO RESET. (THE LED LIGHTS WILL BEGIN TO TRAVEL IN A CIRCLE TO LET YOU KNOW THE NEW SETTING IS NOW PROPERLY PROGRAMMED)
- 6- TO DECREASE SPEED – AFTER #3 ABOVE, KEEP PULSING THE DOWN BUTTON UNTIL YOU HAVE THE NUMBER (SPEED) YOU WANT AND THEN WAIT 5 SECONDS FOR THE DISPLAY TO RESET. (THE LED LIGHTS WILL BEGIN TO TRAVEL IN A CIRCLE TO LET YOU KNOW THE NEW SETTING IS NOW PROPERLY PROGRAMMED)

TO CHANGE ROTATION OF THE MOTOR

- 1- HOLD THE DOWN BUTTON ON THE CONTROL PANNEL UNTIL THE DISPLAY READS 'S.0' (THE 'S' WILL LOOK LIKE A '5')
- 2- PRESS THE UP BUTTON 2 TIMES UNTIL THE DISPLAY READS 'S.2'
- 3- PRESS THE DOWN BUTTON ONCE AND THE UP BUTTON ONCE AND THE MOTOR WILL THEN BE SET TO ROTATE IN THE OPPOSITE DIRECTION (FROM HOW IT WAS TURNING BEFORE YOU STARTED)

IMPORTANT INFORMATION

PLEASE READ

- * USE COMMON SENSE WHEN OPERATING YOUR COBRA MACHINE.
- * OIL MACHINE EVERY 12 HOURS OF SEWING AND ONLY USE SEWING MACHINE OIL OR MINERAL OIL.
- * MAXIMUM SEWING SPEED IS 800 SPM.
- * THREAD SIZES RANGE FROM 138 TO 346. BONDED NYLON THREAD IS RECOMMENDED.
- * CHANGE NEEDLE EVERY 12 HOURS OF SEWING
- * CLEAN OUT THE HOOK ASSEMBLY EVERY 12 HOURS OF SEWING USE. USE AIR, A BRUSH, OR CLOTH..
- * SAVE THE HEAD BOX FOR SHIPPING PURPOSES.
- * PLEASE CALL THE LEATHER MACHINE CO. INC. AT (866) 962-9880 FOR MORE INFORMATION.

THANK YOU FOR YOUR BUSINESS,
WE APPRECAITE IT!

MACHINE TERMINOLOGY

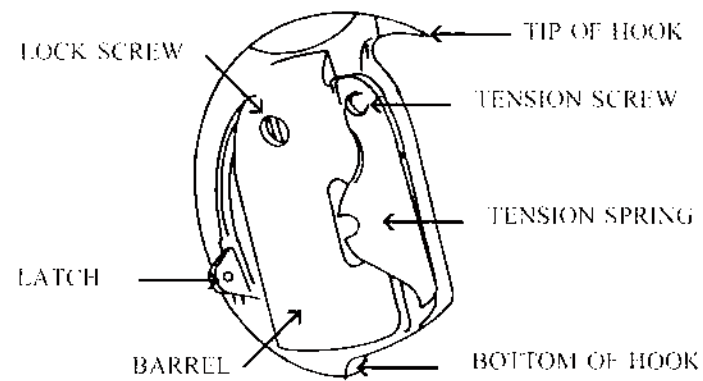
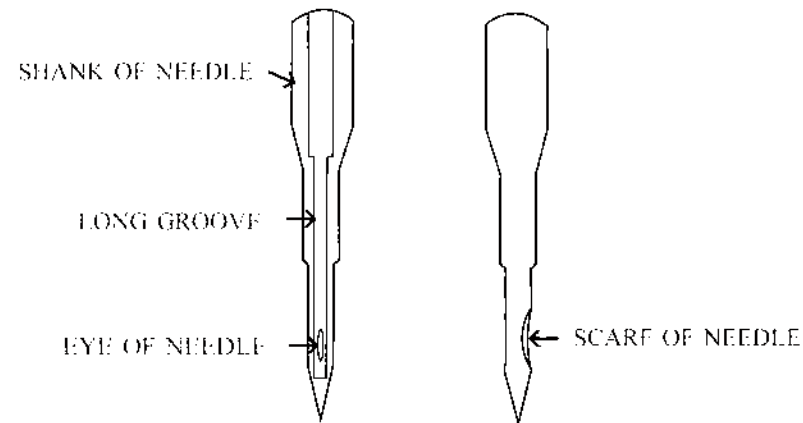

MAIN TENSION -
THIS TENSION HAS THE MOST
TENSION ON THE THREAD

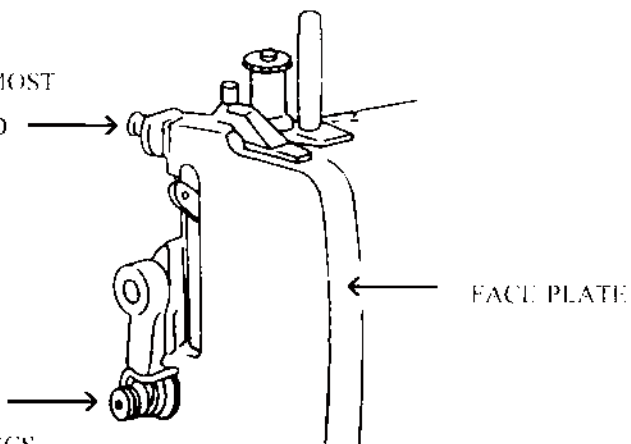

PRE TENSION - THIS IS THE
FINE TUNE KNOB TO LOWER
OR HIGHER THE LOCKSTITCH.
MAKE 1¹/₂ WRAPS AROUND DISCS.

OIL FELT PADS EVERY TIME YOU OIL THE MACHINE

NEEDLE AND THREAD REFERENCE GUIDE

- SEWING 8 OZ. (1/8") OR LESS

USE A #23 NEEDLE WITH A LEATHER POINT OR ROUND POINT.
USE #138 THREAD ON THE TOP AND IN THE BOBBIN.

- SEWING FROM 8 OZ. (1/8") TO 20 OZ. (5/16")

USE A #24 NEEDLE WITH A LEATHER POINT.
USE #207 OR #277 THREAD ON TOP AND IN THE BOBBIN. YOU CAN
USE #277 ON THE TOP AND THE 207 IN THE BOBBIN AS WELL.

- SEWING MORE THAN 20 OZ.

USE A #25 NEEDLE WITH A LEATHER POINT.
USE #277 THREAD OR #346 THREAD ON TOP AND A #277 THREAD IN THE
BOBBIN. DO NOT USE #346 THREAD IN THE BOBBIN.

- SEWING ANYTHING OTHER THAN LEATHER

(BLANKETS, PADS, NYLON WEBBING, CANVAS, BIO-PLASTICS,
UPHOLSTERY ETC.)

USE ROUND POINT NEEDLES. USE THE SAME WEIGHTS AND SIZES AS
WHEN SEWING LEATHER EXCEPT WHEN SEWING BIO-PLASTICS. WHEN
SEWING BIO-PLASTICS, USE A ONE SIZE LARGER NEEDLE.

YOU WILL ALSO WANT TO CHANGE TO THE BLANKET SET. THE BLANKET
SET HAS TEETH TO PULL THE MATERIAL THROUGH. IT CONSISTS OF
THE PRESSER FEET, NEEDLE PLATE AND FEED DOG. THIS SET CAN BE
PURCHASED THROUGH THE LEATHER MACHINE COMPANY INC.

MAINTENANCE TIPS PART 4

LOOSEN THE BOLT AND YOU WILL BE ABLE TO PHYSICALLY TURN THE SHUTTLE HOOK WHILE IT IS IN THE MACHINE. TURN THE SHUTTLE HOOK TO THE CORRECT SETTING, 1/8" ABOVE THE EYE AND THEN TIGHTEN THE BOLT. THIS MAY TAKE MORE THAN ONE TRY.

TIP: A QUICK WAY TO CHECK IF YOUR MACHINE IS OUT OF TIME IS TO LOWER THE NEEDLE. JUST ABOVE THE SCREW THAT HOLDS THE NEEDLE IN PLACE, IS A HOLE THAT YOU CAN LOOK INTO AND SEE THE TOP OF THE NEEDLE. LOOSEN THE SCREW, THEN DROP THE NEEDLE UNTIL IT COVERS HALF OF THE HOLE AND TRY SEWING. IF THE MACHINE SEWS PROPERLY, THEN YOU WILL HAVE TO ADVANCE THE SHUTTLE HOOK ABOUT 1/32". IF IT STILL DOES NOT WORK, THE LOWER THE NEEDLE AGAIN, UNTIL THE TOP OF THE NEEDLE IS EVEN WITH THE BOTTOM OF THE HOLE, AND THEN TRY AGAIN. IF THIS CORRECTS THE PROBLEM THEN YOU WILL HAVE TO ADVANCE THE SHUTTLE HOOK ABOUT 1/16". IF YOUR MACHINE STILL DOES NOT SEW PROPERLY, THEN RETIME YOUR MACHINE BASED ON THE INSTRUCTIONS ABOVE.

THESE ADJUSTMENTS MAY VARY DEPENDING ON THE MACHINE. THESE INSTRUCTIONS OFFERED IN THIS TUTORIAL MAY NOT BE ABSOLUTE, BECAUSE THERE ARE OTHER FACTORS THAT COULD COME INTO PLAY, BUT ARE A GOOD STARTING POINT.

THANK YOU, STEVE

FOR MORE INFO, PLEASE CALL:
LEATHER MACHINE Co., INC.
1-866-962-9880

INSTALLING THE HANDWHEEL

- 1- FIT #1 CLOSE TO THE MAIN SHAFT BUSHING REAR #2.
- 2- ALIGN THE HAND WHEEL WITH THREAD GROVE #A IN THE MAIN SHAFT. TIGHTEN THE FIRST SCREW #3 OF THE HANDWHEEL, THEN TIGHTEN SCREW #4.

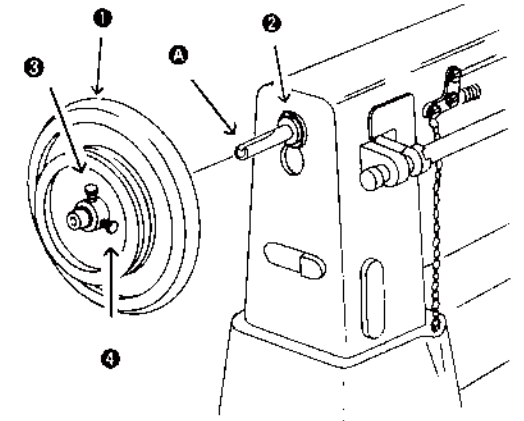

INSTALLING THE THREAD RACK

- 1- YOUR THREAD RACK MOUNTS ON THE BACK SIDE OF THE MACHINE TABLE, IN THE HOLE ON ON THE RIGHT HAND CORNER.
- 2- PLACE THE ROD INTO THE MOUNTING HOLE WITH WASHER AND NUT ON THE UNDERNEATH SIDE OF THE STAND.

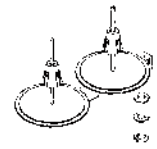

WHEN ALIGNING THE THROAT PLATE

-ATTENTION-

PAY CLOSE ATTENTION TO THE THROAT PLATE ALIGNMENT.

BE SURE THE THROAT PLATE IS ALIGNED SO THAT WHEN THE NEEDLE ENTERS THE SLOT, IT IS CLOSE TO THE LEFT SIDE OF THE SLOT. IT SHOULD BE ABOUT A BUSINESS CARD THICKNESS AWAY FROM THE LEFT SIDE OF THE SLOT.

IF THE NEEDLE IS CENTERED OR TO FAR TO THE RIGHT SIDE OF THE SLOT, IT WILL CAUSE SKIPPED STITCHES OR FRAYING AND BREAKING OF THE THREAD.

LEFT SIDE OF SLOT

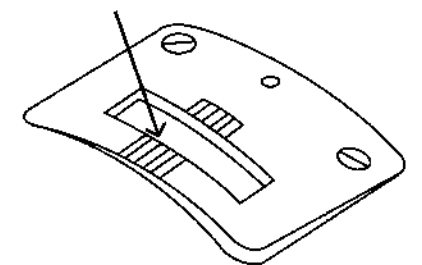

HOW TO INSTALL THE BOBBIN

- 1- PULL APPROXIMATELY 3 TO 4 INCHES OF THREAD OFF THE BOBBIN AND INSERT THE NEW BOBBIN INTO THE BOBBIN CASE SO THAT WHEN TURNING, THE BOBBIN TURNS COUNTER-CLOCKWISE.
- 2- PASS THE THREAD THROUGH SLOT #A OF THE BOBBIN CASE AND PULL THE THREAD UNTIL IT PASSES UNDER THE BOBBIN THREAD TENSION SPRING AND RESTS IN THE GROOVE PICTURED.
- 3- LEAVE AT LEAST 3 TO 5 INCHES OF THREAD REMAINING AND HANGING OUT BEYOND THE BOBBIN CASE.
- 4- TURN HAND WHEEL COUNTER-CLOCKWISE, WITH THE NEEDLE THREADED ONE REVOLUTION, AND THE BOBBIN THREAD WILL BE PULLED UP THROUGH THE NEEDLE PLATE.

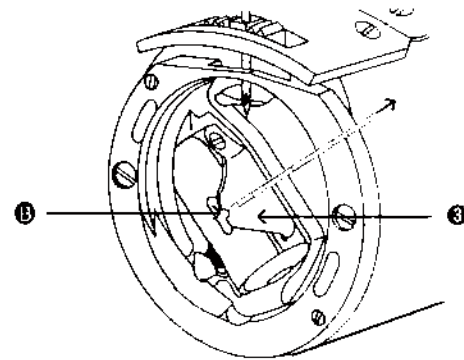
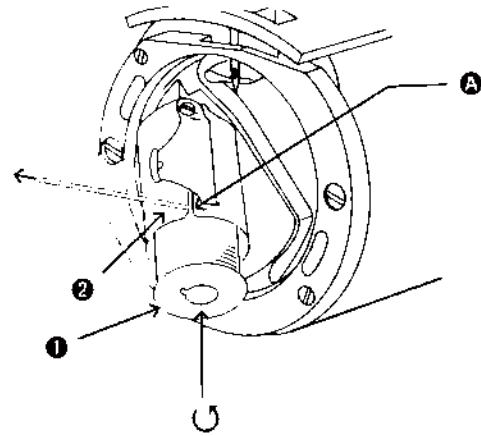

WHEN INSERTING THE BOBBIN

- 1- THE THREAD MUST GO OVER THE TOP OF THE BOBBIN TO THE LEFT.
- 2- RELEASE BOBBIN CASE LATCH TO ALLOW BOBBIN CASE TO SPRING OUT.
- 3- INSERT BOBBIN INTO BOBBIN CASE.
- 4- PULL THREAD INTO SLOT AND UNDER THE TENSION SPRING AND BETWEEN THE "U" SHAPED NOTCH.
- 5- SNAP BOBBIN CASE BACK INTO POSITION.
- 6- ALLOW ABOUT 6 INCHES OF THREAD TAIL.

WHEN TAKING OUT THE BOBBIN

- 1- RAISE THE NEEDLE TO THE HIGHEST POSITION.
- 2- RELEASE THE BOBBIN CASE LATCH TO ALLOW BOBBIN CASE TO SPRING OUT.
- 3- BOBBIN WILL POP OUT ALLOWING YOU TO PULL BOBBIN OUT OF THE BOBBIN CASE.

MAINTENANCE TIPS PARTS 3

NEEDLE DEFLECTOR

-8- THE NEEDLE DEFLECTOR IS LOCATED IN THE SHUTTLE HOOK AREA. IT ACTUALLY DEFLECTS THE NEEDLE TO PROTECT THE POINT OF THE HOOK. THE NEEDLE WILL BRUSH AGAINST THE DEFLECTOR MOVING THE NEEDLE SLIGHTLY TO THE LEFT OF THE POINT OF THE HOOK. IT ALSO KEEPS THE NEEDLE STRAIGHT, ASSURING THAT THE LOOP MADE BY THE THREAD IS CONSISTENT.

PRESSER FEET TIMING

-9- BOTH PRESSER FEET SHOULD RISE TO THE SAME HEIGHT AS THEY ALTERNATE WALKING. THE PROCEDURE TO ASSURE THAT YOUR PRESSER FEET ARE WALKING CORRECTLY IS TO TURN THE HAND WHEEL TOWARDS YOU UNTIL THE POINT OF THE NEEDLE IS EVEN WITH THE PLATE OR FEED DOG. AT THIS TIME BOTH PRESSER FEET SHOULD BE DOWN. THE NEEDLE, AND BOTH PRESSER FEET SHOULD MEET AT THE PLATE OR FEED DOG AT THE SAME TIME. IF THIS IS NOT THE CASE, THEN LOOSEN THE ADJUSTING SCREW AND MAKE THE ADJUSTMENT. THE ADJUSTING SCREW IS LOCATED ON THE FAR RIGHT SIDE ON THE BACK OF THE MACHINE. IT IS AN ALLEN HEAD SCREW.

PRESSER FEET HEIGHT

-10- THE PRESSER FEET HEIGHT IS DETERMINED BY WHAT YOU ARE SEWING. FOR THE MOST PART, THE HEIGHT IS SET AT MEDIUM TO HIGH. THIS WILL ALLOW MOST APPLICATIONS TO FEED (WHETHER THICK OR THIN) WITHOUT GETTING CAUGHT ON THE FEET AND IMPEDING THE MOTION OF THE FEED SYSTEM. IF YOU ARE MANUFACTURING ONE ITEM, LIKE BELTS, WHERE THE THICKNESS IS CONSTANT, THEN YOU WOULD SET THE HEIGHT TO ACCOMMODATE THE BELTS THICKNESS. THIS ADJUSTMENT IS IN THE BACK OF THE MACHINE, AND IS SOMETIMES REFERRED TO AS THE "BANANA SLIDE" ADJUSTMENT.

HOOK TIMING

-11- TO SET THE TIMING FOR THE HOOK, FIRST REMOVE THE NEEDLE PLATE AND IN SOME CASES, THE FEED DOG. THIS WILL ALLOW YOU MAXIMUM VISION. SET THE STITCH LENGTH TO ZERO. PUT A NEW NEEDLE IN THE MACHINE. RAISE THE PRESSER FEET TO THE UP POSITION. TURN THE HAND WHEEL TOWARDS YOU UNTIL THE NEEDLE IS IN THE LOWEST POSITION. CONTINUE TO TURN THE HAND WHEEL UNTIL THE NEEDLE COMES UP 3/16", THIS MEASUREMENT IS CRITICAL. AT THIS TIME, THE POINT OF THE HOOK SHOULD BE EVEN WITH THE NEEDLE AND APPROXIMATELY 1/8" ABOVE THE EYE OF THE NEEDLE, AND IN THE SCARF OF THE NEEDLE AS WELL. TO ADJUST THE SHUTTLE HOOK, REMOVE THE ROUND COVER PLATE ON THE FRONT OF THE MACHINE LOCATED IN THE LOWER RIGHT HAND SIDE. AFTER REMOVING THE COVER PLATE, LOOK INSIDE THE MACHINE AND YOU WILL FIND THE BLACK ALLEN HEAD BOLT THAT HOLDS THE HOOK DRIVING SHAFT. YOU MAY HAVE TO TURN THE HAND WHEEL TO GET A BETTER VIEW OF THIS BOLT.

MAINTENANCE TIPS PART 2

TENSIONS

-6- THE THICKNESS OF THE LEATHER THAT YOU ARE SEWING WILL DICTATE THE AMOUNT OF TENSION THAT YOU WILL NEED. YOU SHOULD LOOSEN THE TENSIONS FOR LIGHTER LEATHER. YOUR TENSIONS WORK IN CONJUNCTION WITH EACH OTHER, SO YOU SHOULD LOOSEN OR TIGHTEN BOTH TENSIONS WHEN ADJUSTING THEM. YOU SHOULD NEVER LOOSEN OR TIGHTEN MORE THAN 1 FULL TURN AT A TIME. IF YOU RUN INTO A PROBLEM WITH YOUR TENSION AND YOU ARE NOT SURE WHICH WAY TO TURN OR YOU JUST CAN'T SEEM TO GET YOUR TENSION BACK WHERE THEY WERE, THEN IT IS TIME TO RE-CALIBRATE THEM. THIS IS A SIMPLE TASK. TO RE-CALIBRATE YOUR TENSIONS, REMOVE BOTH KNURLED TENSION NUTS COMPLETELY, THEN PUT THEM BOTH BACK ON THE MACHINE UNTIL THEY JUST COME IN CONTACT WITH THE TENSION SPRING AND STOP. SEW A TEST PIECE. YOU WILL PROBABLY FIND THAT THE STITCH IS LOOSE, BUT THIS IS WHAT WE WANT. YOU ARE NOW ABLE TO ADJUST YOUR TENSION BY TIGHTENING THEM BOTH 1 TURN AT A TIME UNTIL THE STITCH PULLS UP. YOU MAY ALSO EXPERIENCE BOBBIN TENSION PROBLEMS. IF YOU HAVE TIGHTENED THE BOBBIN TENSION AS FAR AS YOU CAN, AND STILL THERE IS NOT ENOUGH TENSION (THE BOBBIN THREAD IS VISIBLE ON TOP OF THE LEATHER), YOU MAY HAVE TO CLEAN OUT UNDER THE BOBBIN CASE SPRING. AFTER HUNDREDS OF YARDS OF THREAD PASS UNDER THE BOBBIN CASE SPRING, MICROSCOPIC FIBERS OF THREAD, ALONG WITH LEATHER DUST AND OTHER DEBRIS, START TO COLLECT UNDER THE BOBBIN CASE SPRING CAUSING THE SPRING TO SPREAD AND GIVE FALSE TENSION. IF THIS IS THE CASE, THEN YOU WILL HAVE TO REMOVE THE SPRING, CLEAN OUT THE DEBRIS, AND MAY HAVE TO BEND THE SPRING TO PUT MORE PRESSURE ON THE THREAD WHICH WILL GIVE YOU MORE TENSION AND ALLOW YOU TO BE ABLE TO ADJUST YOUR BOBBIN TENSION AS WELL. YOU MAY HAVE TO PURCHASE A NEW BOBBIN CASE SPRING IF RE-SHAPING YOUR EXISTING SPRING DOES NOT WORK.

SHUTTLE HOOK

-7- IT IS VERY IMPORTANT THAT YOUR SHUTTLE HOOK IS IN EXCELLENT CONDITION. IF YOUR HOOK HAS BURRS, OR SCRATCHES, THEN YOU MUST BUFF THEM OFF TO MAKE YOUR HOOK SMOOTH AGAIN SO THE THREAD WILL PASS OVER THE HOOK WITH EASE. IF YOUR THREAD IS FRAYING, THEN A BURR IS MOST LIKELY THE PROBLEM. THE THREAD WILL PASS OVER THE BURR AND THEN GET CAUGHT, CAUSING A COUPLE OF THE STRANDS TO BREAK. YOU SHOULD RUN YOUR FINGER NAIL OVER THE TOP, SIDES, UNDER, AND AT THE POINT OF THE HOOK WHEN FEELING FOR BURRS.

THE SHUTTLE HOOK TRAVELS IN THE RACE ASSEMBLY. YOU SHOULD CLEAN OUT THE RACE ASSEMBLY FREQUENTLY. THE RACE ASSEMBLY MUST BE CLEAN, SMOOTH, AND OILED TO ASSURE THE BEST SEWING RESULTS.

HOW TO INSTALL THE NEEDLE

- 1-** TURN HAND WHEEL COUNTER-CLOCKWISE AND RAISE THE NEEDLE BAR TO IT'S HIGHEST POSITION.
- 2-** LOOSEN NEEDLE SET SCREW #1, REMOVE NEEDLE AND REPLACE WITH NEW NEEDLE #2 INTO THE NEEDLE BAR. PUSH IT UP AS FAR AS IT WILL GO.
- 3-** REMEMBER TO LOCATE THE NEEDLE SCARF #A TOWARDS THE HAND WHEEL AND THE LONG GROOVE OF THE NEEDLE TO THE LEFT SIDE.
- 4-** SECURELY TIGHTEN THE NEEDLE SET SCREW #1.

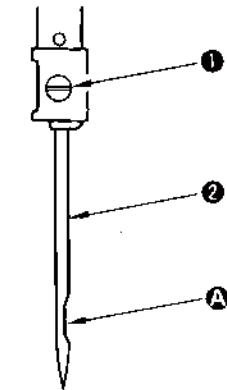

WHEN INSTALLING THE NEEDLE

- 1-** TURN OFF POWER
- 2-** TURN THE HAND WHEEL UNTIL THE NEEDLE IS IN THE HIGHEST POSITION.
- 3-** LOOSEN NEEDLE SET SCREW AND INSERT NEEDLE INTO THE NEEDLE CLAMP HOLE
- 4-** MAKE SURE THAT THE LONG GROOVE OF THE NEEDLE IS FACING LEFT.
- 5-** TIGHTEN NEEDLE SET SCREW

WINDING THE BOBBIN ON A COBRA CLASS 3

- 1- THE COBRA CLASS 3 HAS A BOBBIN WINDER THAT MOUNTS ON THE TABLE.
- 2- USING THE SPOOL HOLDER ON THE RIGHT SIDE OF THE THREAD STAND, TAKE THE THREAD UP TO THE CROSS BAR AND THROUGH THE EYELET ON THE RIGHT.
- 3- THREAD THE TENSION ASSEMBLY AT THE BACK OF THE BOBBIN WINDER, GO THROUGH THE HOLE AND SNAP THE THREAD BETWEEN THE TENSION DISCS. THE THREAD THEN GOES AROUND THE DISC IN A CLOCKWISE MOTION AND OVER THE GUIDE THAT IS POSITIONED BETWEEN THE TENSION ASSEMBLY, AND THE SPINDLE THAT THE BOBBIN GOES ON.
- 4- THE BOBBIN HAS A LITTLE HOLE ON BOTH SIDES. THREAD ONE OF THE HOLES GOING LEFT TO RIGHT. THE OTHER HOLE WILL SLIP ONTO THE LITTLE PIN AT THE LEFT SIDE OF THE SPINDLE WHERE THE BOBBIN RESTS AGAINST.
- 5- THE BOBBIN SHOULD FIT SNUG ON THE SPINDLE.
- 6- WITH ABOUT 6 INCHES OF TAIL, ENGAGE THE BOBBIN WINDER BY PUSHING THE PIECE THAT MOVES THE BOBBIN WINDER WHEEL AGAINST THE BELT.
- 7- AS YOU SEW, THE BOBBIN WILL WIND. HOLD THE TAIL UNTIL THE THREAD WINDS EVENLY ONCE TO THE LEFT AND ONCE TO THE RIGHT.
- 8- AT THIS TIME YOU CAN TRIM THE TAIL OFF AND CONTINUE SEWING UNTIL THE BOBBIN IS FULL.
- 9- YOU CAN ALSO WIND BOBBINS WHEN YOU ARE NOT SEWING BY RAISING THE PRESSER FOOT, REMOVING THE BOBBIN, AND UNTHREADING THE NEEDLE. YOU WILL PROBABLY WANT TO TURN THE SPEED UP ON THE MOTOR WHEN WINDING BOBBINS USING THIS METHOD.

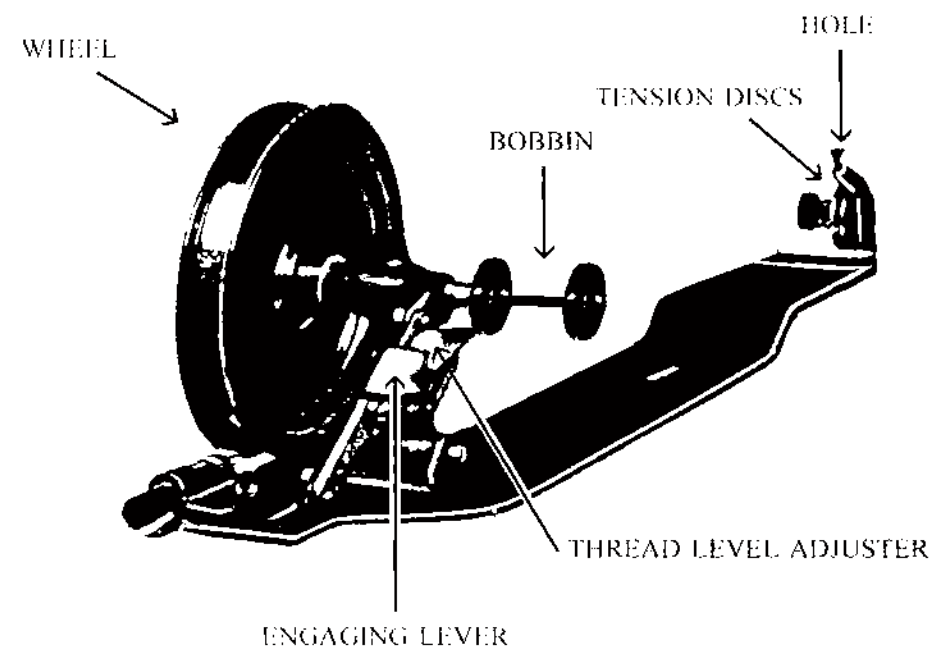

MAINTENANCE TIPS PART 1

THREAD

- 1- MAKE SURE THAT THE THREAD YOU ARE USING IS NOT DRY, OLD, OR DAMAGED BY THE ELEMENTS. KEEP THREAD IN A PLASTIC BAG TO HELP PROTECT IT. MAKE SURE THAT THE THREAD DOES NOT UNTWIST, IF SO, THEN THE BONDING AGENTS HAVE EVAPORATED OR WEREN'T VERY GOOD TO BEGIN WITH.

THREADING

- 2- MAKE SURE THAT YOUR MACHINE IS THREADED CORRECTLY. BREAKING THREAD, SKIPPING, FRAYING THE THREAD, AND TENSION PROBLEMS WILL OCCUR IF YOUR MACHINE IS THREADED INCORRECTLY.

TAKE UP LEVER

- 3- THE TAKE UP LEVER HAS 2 FUNCTIONS: TO GIVE THE THREAD ENOUGH SLACK SO THE HOOK CAN CARRY THE THREAD AROUND THE BOBBIN CASE, AND, AFTER THE HOOK RELEASES THE THREAD, ALLOWS THE THREAD TO PULL UP INTO THE LEATHER.

CHECK SPRING

- 4- THE CHECK SPRING MAINTAINS TENSION ON THE THREAD AS THE TAKE UP LEVER RETURNS TO THE TOP POSITION.

NEEDLES

- 5- THE NEEDLE MUST BE INSTALLED CORRECTLY. MAKE SURE THAT THE LONG GROOVE IS ON THE LEFT, AND THE SCARF IS ON THE RIGHT. NEEDLES ARE TEMPERED, SO AFTER USAGE, THEY LOSE THEIR TEMPER AND BECOME WEAK. A WEAK NEEDLE WILL BEND OR BREAK EASIER AFTER LOSING ITS TEMPER. WHEN THE NEEDLE BREAKS, IT COULD CAUSE DAMAGE TO THE PRESSER FOOT, NEEDLE PLATE, FEED DOG, OR SHUTTLE HOOK, SO MAKE SURE THAT YOU CHANGE YOUR NEEDLE EVERY 12 HOURS OF ACTUAL SEWING. ALSO, MAKE SURE THAT YOU USE THE CORRECT SIZE NEEDLE FOR THE THREAD AND THICKNESS OF LEATHER THAT YOU ARE USING. IF YOU ARE USING TOO BIG OF A NEEDLE, THEN AT TIMES, THE THREAD WILL TRAVEL UP AND DOWN INSIDE THE HOLE THAT THE NEEDLE PUNCHED RESEMBLING A TENSION PROBLEM. IT IS ALL RELATIVE. THE HEAVIER THE LEATHER, THE HEAVIER THE NEEDLE AND THREAD. THE LIGHTER THE LEATHER, THE LIGHTER THE NEEDLE AND THREAD.

SHUTTLE HOOK PART NUMBERS

<u>PART NUMBER</u>	<u>DESCRIPTION</u>
210-48150	SHUTTLE HOOK COMPLETE
210-41801	SHUTTLE
210-42007	LATCH SPRING
210-42304	LATCH SPRING SCREW
210-42403	PIN
210-42700	RETURN SPRING
210-41900	BARREL
210-42502	STOP SCREW (ALSO #05662010)
210-42205	SET SCREW
210-42601	BACKLASH SPRING
210-42106	TENSION SPRING
210-57401	BOBBIN (ALSO #76-11)

note: the barrel #210-41900 and the shuttle #210-41801 can not be purchased seperately. you have to purchase the shuttle hook complete.

WINDING THE BOBBIN ON A COBRA CLASS 4

- 1- THE COBRA CLASS 4 HAS A BUILT IN BOBBIN WINDER, USING THE SPOOL HOLDER ON THE RIGHT SIDE OF THE THREAD STAND, THREAD THE EYELET ON THE RIGHT SIDE OF THE CROSS BAR.
- 2- THREAD THE TENSION ASSEMBLY ON THE TOP OF THE MACHINE CLOSEST TO THE HAND WHEEL.
- 3- THREAD THE BACK HOLE FIRST ON THE THREAD GUIDE, THEN BETWEEN THE TENSION DISCS ON THE LEFT SIDE OF THE ASSEMBLY BRINGING THE THREAD TO THE FRONTHOLE ON THE THREAD GUIDE.
- 4- THREAD THE THREAD GUIDE ON THE FRONT OF THE MACHINE THAT IS POSITIONED AT THE LEFT SIDE OF THE MACHINE.
- 5- BRING THE THREAD TO THE BOBBIN (USING THE SAME TECHNIQUE AS THE CLASS 3).
- 6- PUSH THE LEVER DOWN UNTIL IT SNAPS IN BETWEEN THE BOBBIN AND START SEWING, HOLDING THE TAIL AS YOU START.
- 7- TRIM THE THREAD WHEN THE THREAD HAS GONE BACK AND FORTH. THE BOBBIN WILL DISSENGAGE WHEN THE BOBBIN IS FULL.

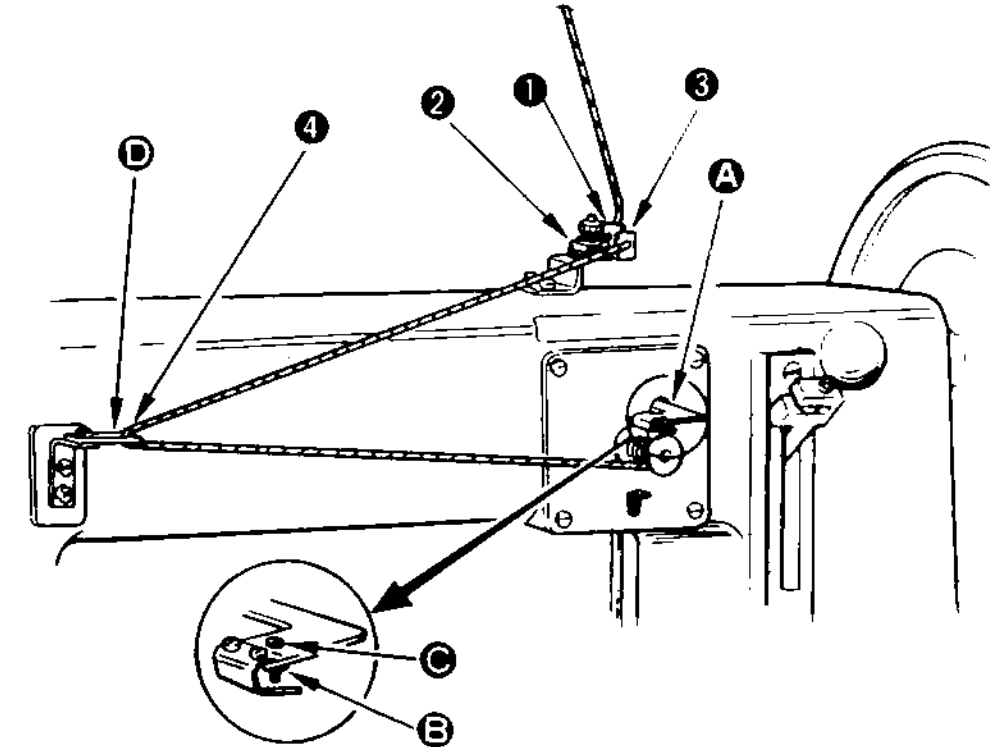

HOW TO THREAD THE MACHINE

- 1- RAISE THE TAKE UP LEVER TO IT'S HIGHEST POSITION.
- 2- THREAD SITS ON LEFT SPOOL HOLDER ON THREAD STAND.
- 3- TAKE THREAD OFF THE SPOOL AND THREAD TOP CROSS BAR IN LEFT THREAD EYELET.
- 4- THREAD THE TOP TENSION ASSEMBLY (MAIN TENSION #2) ON THE FACE PLATE, THEN PLACE THE THREAD BETWEEN THE TENSION DISCS #3. MAKE SURE THAT YOU SNAP THE THREAD INTO THE DISCS. THE THREAD MUST BE SNAPPED TIGHTLY INTO THE TENSION DISCS. GO AROUND THE TENSION ASSEMBLY, THEN GO BACK THROUGH THE SAME EYELET. THIS WILL PREVENT THE THREAD FROM SNAPPING OUT OF THE DISCS.
- 5- GO STRAIGHT DOWN THROUGH THE ROLLER TENSION EYELET #5 AND WRAP THREAD AROUND COUNTER-CLOCKWISE 2 TIMES. ON THE SECOND WRAP, BRING THE THREAD THROUGH THE EYELET.
- 6- THREAD CHECK SPRING #4.
- 7- THREAD THE TAKE UP LEVER #7.
- 8- GO DOWN TO THE SUB TENSION AND PUT YOUR FINGER BEHIND THE ANGLED PIECE AND PULL IT OUT. THREAD THROUGH THE FLAT PLATES TO THE LEFT OF THE SCREW #8.
- 9- THREAD THROUGH THE LOWER THREAD GUIDE #9.
- 10- THREAD THE HOLE ON THE NEEDLE CLAMP #10.

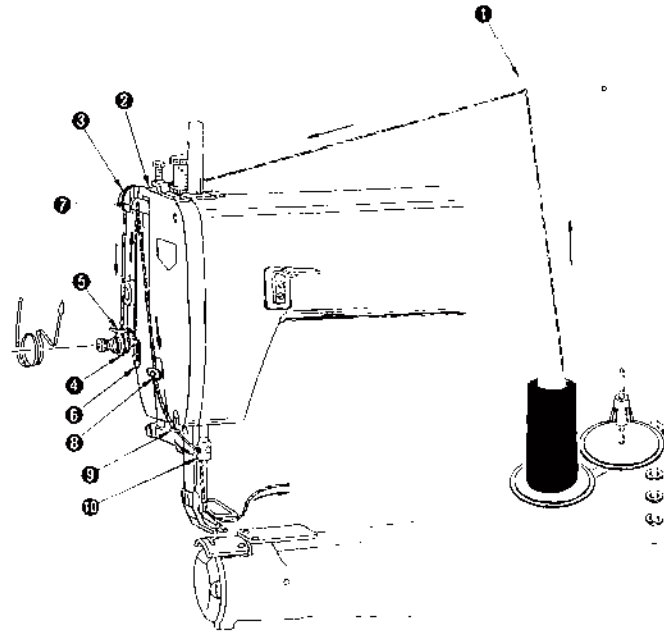

ADJUSTING THE STITCH LENGTH - REVERSE SEWING

- 1- TO ADJUST THE STITCH LENGTH, USE THE FEED REGULATOR NUT #1. RAISE THE FEED REGULATOR #A TO THE DESIRED AMOUNT. THE NUMBERS ON THE PLATE ARE IN MM, AND ARE JUST A REFERENCE POINT. THE HIGHER YOU RAISE THE LEVER, THE SHORTER THE STITCH LENGTH.
- 2- RIGHT IN THE MIDDLE OF THE PLATE IS THE 0 (ZERO) STITCH. AT THIS POINT YOU ARE ABOUT TO GO IN REVERSE.
- 3- ONCE YOU FIND THE DESIRED STITCH LENGTH, TIGHTEN THE REGULATOR NUT #1. THIS WILL ALLOW YOU TO HAVE THE SAME STITCH LENGTH IN REVERSE AND FORWARD.

REVERSE STITCHING

TO CARRY OUT REVERSE STITCHING, PUSH THE FEED LEVER UP AS FAR AS IT WILL GO.

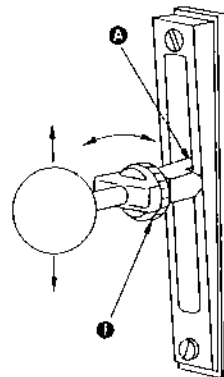

SHUTTLE HOOK COMPONENTS

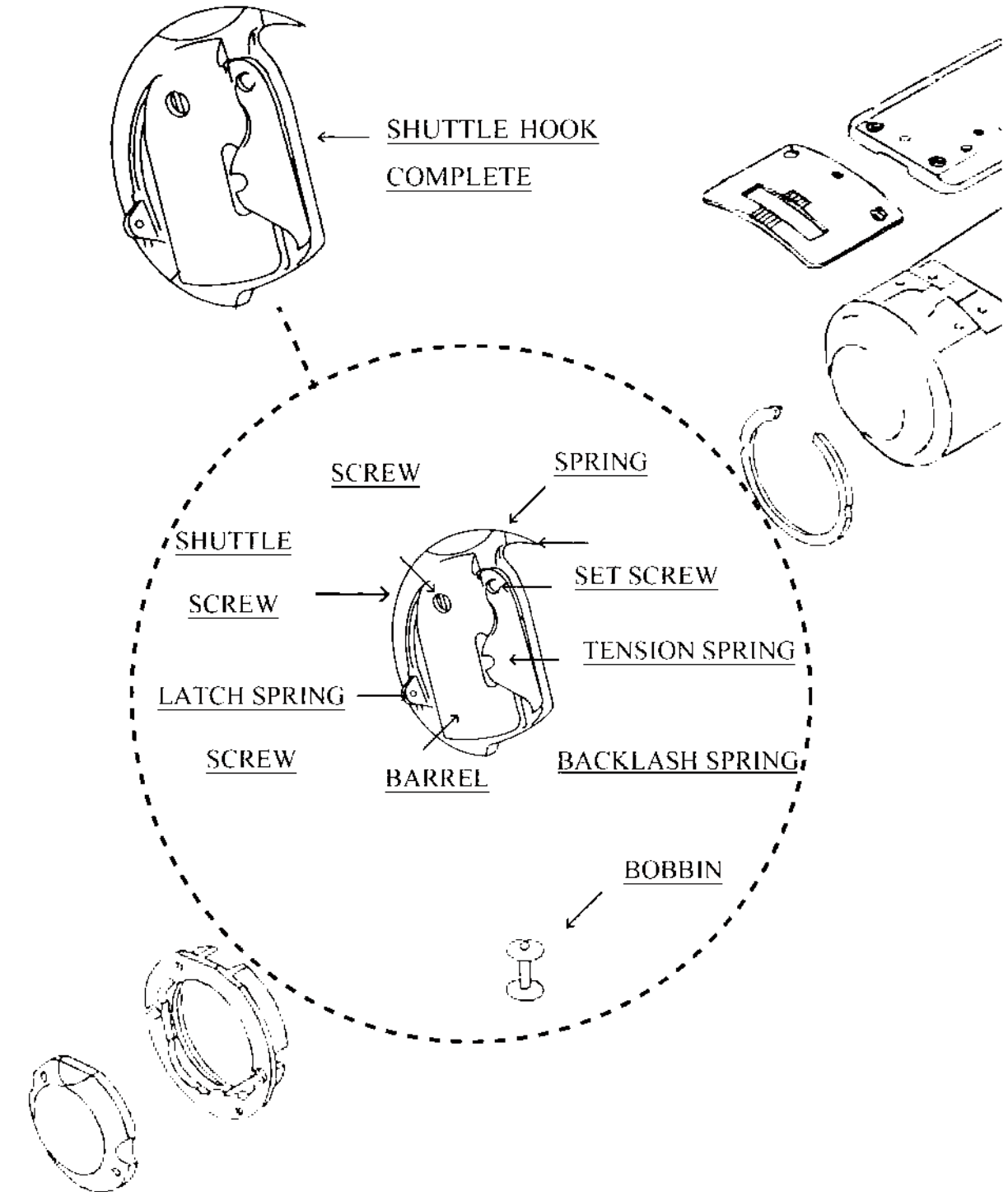

CLEANING THE SHUTTLE HOOK AREA

TO DISASSEMBLE

- 1- REMOVE THE TWO OUTER RACE SCREWS.
(DO NOT LOSE THE SPRINGS)
- 2- REMOVE OUTER RACE.
- 3- REMOVE THE SHUTTLE.
- 4- REMOVE INNER RACE.
- 5- CLEAN ALL DEBRIS IN SHUTTLE AREA OUT.

TO ASSEMBLE

- 1- REPLACE INNER RACE. BE SURE THAT THE BEVELED EDGE GOES IN TOWARD THE MACHINE. (SEE BELOW)
- 2- REPLACE SHUTTLE.
- 3- REPLACE THE OUTER RACE AND RACE SCREWS.
- 4- PUT A COUPLE DROPS OF OIL ON RACE AND CYCLE THE MACHINE.

BEVELED EDGE

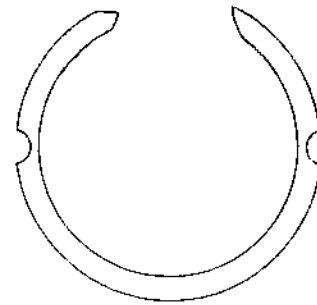

TIMING THE SHUTTLE HOOK

- 1- REMOVE NEEDLE PLATE.
- 2- REPLACE NEEDLE.
- 3- RAISE PRESSER FOOT.
- 4- TURN HAND WHEEL TOWARDS YOU (COUNTER-CLOCKWISE) UNTIL THE NEEDLE BOTTOMS OUT.
- 5- CONTINUE TURNING HAND WHEEL UNTIL NEEDLE RAISES 3/16 OF AN INCH.
- 6- AT THIS POINT, THE POINT OF THE SHUTTLE HOOK SHOULD BE AT THE NEEDLE. IF NOT, OPEN INSPECTION COVER LOCATED ON THE LOWER RIGHT CORNER OF THE MACHINE.
- 7- TURN HAND WHEEL UNTIL YOU SEE A BLACK ALLEN HEAD BOLT, THEN LOOSEN IT.
- 8- YOU SHOULD BE ABLE TO MOVE THE SHUTTLE HOOK ASSEMBLY BY HAND, ADJUSTING IT TO THE CORRECT LOCATION. (SEE #6)
- 9- WHEN THE SHUTTLE HOOK IS IN THE CORRECT LOCATION, TIGHTEN THE ALLEN BOLT.
- 10- IF THE MACHINE IS STILL SLIGHTLY OUT OF TIME, REPEAT STEPS. YOU ARE PROBABLY VERY CLOSE TO HAVING IT RIGHT. IF YOU NEED TO ADVANCE OR RETARD THE HOOK, THEN DO SO EVER SO SLIGHTLY.

SEWING TIPS

- 1- WHEN SEWING IN REVERSE, OR BACK TACKING, WHEN YOU COME TO THE POINT WHERE YOU WANT TO START YOUR BACK TACK, MANUALLY TURN THE HAND WHEEL TOWARDS YOU UNTIL THE NEEDLE IS IN IT'S LOWEST POSITION. CONTINUE TO TURN THE HAND WHEEL UNTIL THE NEEDLE COMES UP 1/4 OF AN INCH. RAISE THE REVERSE LEVER UNTIL IT STOPS. THEN START SEWING. IF YOU GUIDE THE LEATHER STRAIGHT, YOU WILL SEW BACK INTO THE SAME HOLES THAT YOU SEWED FORWARD IN FOR A PERFECT UNIFORM BACK TACK.
- 2- WHEN DOING 90 DEGREE CORNERS, YOU WILL WANT TO USE THE SAME TECHNIQUE AS SEWING IN REVERSE. TURN THE HAND WHEEL TOWARDS YOU UNTIL THE NEEDLE IS IN IT'S LOWEST POSITION. CONTINUE TO TURN THE HAND WHEEL UNTIL THE NEEDLE COMES UP 1/4 OF AN INCH. RAISE THE PRESSER FEET WITH THE SMALL PEDAL, THEN PIVOT YOUR WORK UPON THE NEEDLE THEN DROP THE PRESSER FEET. START TO SEW. YOU WILL NOT DROP THE STITCH IF YOU USE THIS METHOD.
- 3- WHEN REPAIRING A SADDLE OR ANYTHING WHERE YOU HAVE TO SEW INTO EXISTING HOLES, YOU CAN USE THE STITCH LENGTH LEVER TO MOVE THE POSITION OF THE NEEDLE. YOU RAISE OR LOWER THE LEVER UNTIL THE NEEDLE LINES UP WITH THE HOLE. START TO SEW VERY SLOWLY AND CAREFULLY.
- 4- ALWAYS HOLD THE TWO THREADS WHEN YOU START TO SEW. SEW 3 OR 4 STITCHES, THEN TRIM BOTH THREADS.

SERVICE TIPS

THE FOLLOWING LIST OF SERVICE TIPS ARE DESIGNED TO HELP YOU WITH MINOR ADJUSTMENTS.

THESE ADJUSTMENTS WILL KEEP YOUR MACHINE PERFORMING AT IT'S HIGHEST LEVEL. AFTER YOU HAVE MADE THE NECESSARY ADJUSTMENTS, AND YOU ARE STILL HAVING PROBLEMS, PLEASE CALL STEVE AT THE LEATHER MACHINE COMPANY INC. (866) 962-9880. I WILL HELP YOU OVER THE PHONE.

THANK YOU,
STEVE TAYRIEN

ADJUSTING THE PRESSER FOOT PRESSURE

- 1- THE OUTSIDE PRESSER FOOT PRESSURE IS ADJUSTED BY LOOSENING NUT #3.
- 2- TO INCREASE THE HOLDING CAPACITY OF THE OUTSIDE PRESSER FOOT, TURN THE REGULATOR #1 CLOCKWISE.
- 3- TO REDUCE THE HOLDING PRESSURE, TURN THE REGULATOR COUNTER-CLOCKWISE. BE CAREFUL NOT TO FULLY UNSCREW THE REGULATOR. IT IS SPRING LOADED IT WILL POP OUT.
- 4- TIGHTEN THE LOCKING NUT #3.

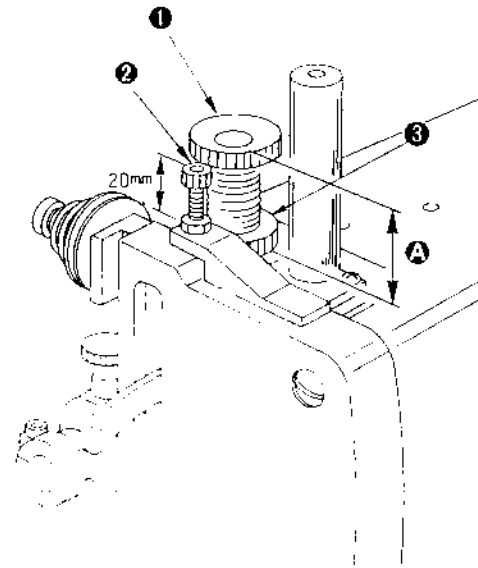

THREAD TENSION

ADJUSTING NEEDLE THREAD TENSION

- 1- ADJUST NEEDLE THREAD TENSION BY TENSION NUT #1.
- 2- TO INCREASE THE NEEDLE THREAD TENSION, TURN THE NUT CLOCKWISE TOWARDS #A.
- 3- TO DECREASE THE NEEDLE THREAD TENSION, TURN THE NUT COUNTER-CLOCKWISE TOWARDS #B.

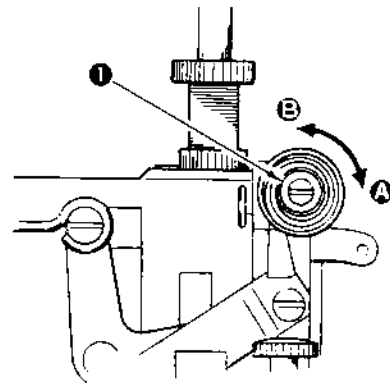

ADJUSTING BOBBIN THREAD TENSION

- 1- TO ADJUST BOBBIN THREAD TENSION LOOSEN LOCK SCREW #1.
- 2- TURN SCREW #2 CLOCKWISE TO INCREASE BOBBIN THREAD TENSION.
- 3- TURN SCREW #2 COUNTER-CLOCKWISE TO DECREASE THREAD TENSION.
- 4- AFTER THE BOBBIN THREAD TENSION HAS BEEN ADJUSTED, TIGHTEN SCREW #1 FIRMLY BUT NOT TO TIGHT, YOU CAN BREAK THE SCREW OFF.

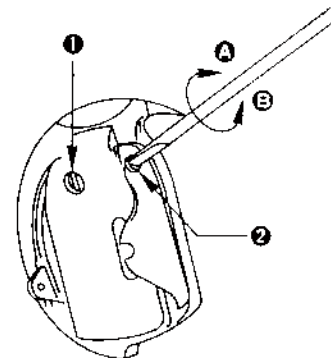

ADJUSTING THE HEIGHT OF THE FEED DOG

REMOVING THE FEED DOG AND ADJUSTING THE HEIGHT

- 1- REMOVE NEEDLE PLATE.
- 2- REMOVE RACE SCREWS #1.
- 3- REMOVE RACE ASSEMBLY #2.
- 4- REMOVE SHUTTLE HOOK #3.
- 5- TURN THE HAND WHEEL UNTIL THE SHUTTLE DRIVER #5 IS OUT OF THE WAY AND REVEALING THE FEED DOG SCREW #4.
- 6- LOOSEN THE FEED DOG SCREW #4 AND REMOVE THE FEED DOG.
- 7- THE HEIGHT OF THE FEED DOG SHOULD BE 1/16" ABOVE THE NEEDLE PLATE AT IT'S HIGHEST POSITION.

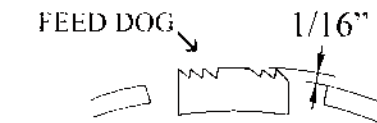
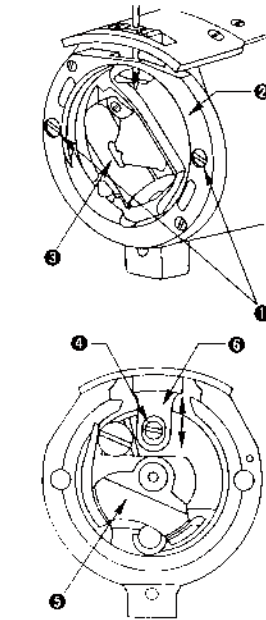

WALKING FOOT HEIGHT ADJUSTMENT

- 1- LOOSEN NUT #6 AND MOVE THE LEVER #7 UP TO DECREASE THE WALKING FOOT HEIGHT (B).
- 2- MOVE THE LEVER #7 DOWN IN SLOT BRACKET #8 TO INCREASE THE WALKING FOOT HEIGHT.
- 3- TIGHTEN THE NUT #6 AFTER COMPLETING THE ADJUSTMENT.

