

# QUIVER PAPER PATTERN

**NOTE:** Paper Patterns are intended for experienced leathercrafters.

## RECOMMENDED MATERIALS

10 to 11 oz. Stiff Tempered Leather  
(3.5 sq. ft.)  
6 to 7 oz Stiff Tempered Leather  
(2 sq. ft.)  
1 in. Buckle  
1 in. Premade Keeper  
Chicago Screws (4)

## REQUIRED TOOLS

Knife  
Straight Edge  
Mallet  
Scratch Awl  
Pricking Irons or Stitching Chisels  
Harness Needles & Thread  
Binder Clips or Similar  
3/16 in. Round Drive Punch  
7/32 in. Oval Punch  
1 in. Oblong Punch  
1 in. Belt End Punch  
Small Screwdriver

## RECOMMENDED TOOLS

Leather Stapler (if assembling own Keeper)  
Edge Finishing Materials  
Preferred Adhesive  
Stitching Horse

LABEL	PATTERN PIECE	PIECES REQUIRED	RECOMMENDED LEATHER WEIGHT
A	Back Body	1	10 to 11 oz.
B	Front Body	1	6 to 7 oz.
C	Top Strap	1	10 to 11 oz.
D	Buckle Strap	1	10 to 11 oz.
E	Keeper	1	6 to 7 oz.

Please note the type of leather and tools you use will affect the outcome. Please use your best judgment when assembling your project. We recommend outlining the order of operations, measure and count twice before making any permanent alterations to your pattern.

# PROJECT OVERVIEW

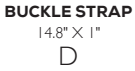
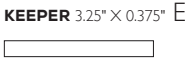
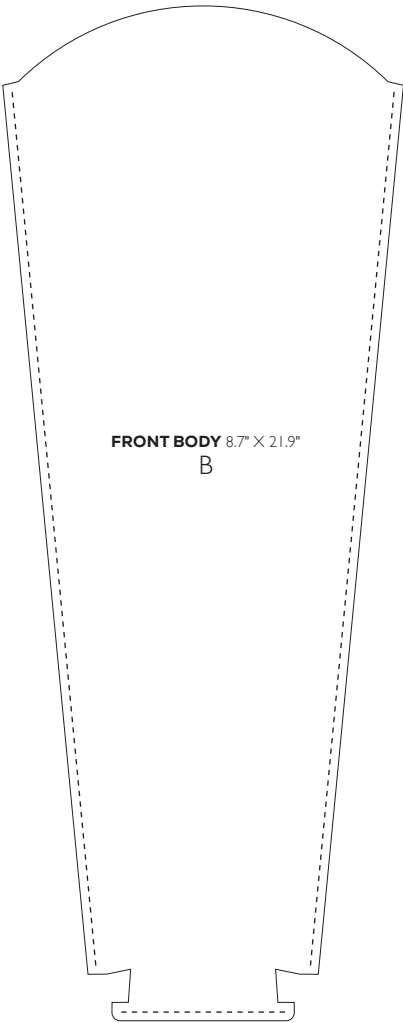
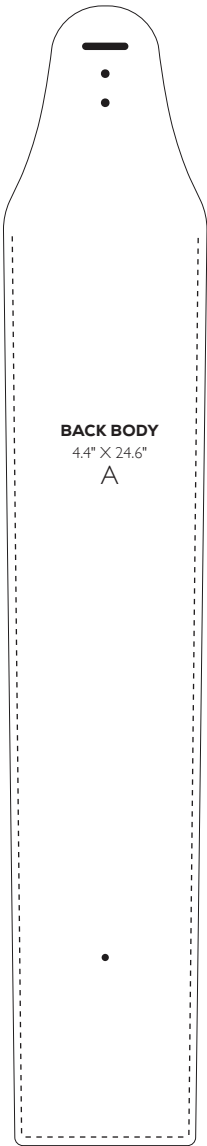

● PUNCH

———— CUT

- - - - - STITCH

## PAPER PATTERN CARE INSTRUCTIONS

OPTION 1: Before cutting out pattern pieces, adhere a stiffer paper (cardstock or similar) with preferred adhesive.

OPTION 2: After cutting out pattern pieces, laminate individual pieces.

These are suggestions to prolong the lifespan of the paper pattern. With proper care, these patterns can be used again and again!

## ASSEMBLY INSTRUCTIONS

1. Cut and punch required pieces. Before assembly, take the necessary steps to prepare leather and edges. We recommend cutting and trimming the Top Strap (C) last for a better fit to size.
2. Prepare Keeper (E) by stapling or stitching.
3. Secure the 1 in. Buckle through the oblong punch on Buckle Strap (D), flesh sides together. Secure the first hole with a Chicago Screw.
- 4A. **For secured Keeper (E)**, slide the Keeper (E) on, then secure the next hole with a Chicago Screw.
- 4B. **For a sliding Keeper (E)**, slide the Keeper (E) on after both Chicago Screws are secured.
5. Attach flesh side of Buckle Strap (D) to “the bottom” grain side of Back Body (A) with a Chicago screw. The Chicago screw being centered on Back Body (A) allows this strap to swivel and be worn for both left and right-handed archers.
6. Saddle stitch Front Body (B) to Back Body (A), flesh sides together.
7. **OPTIONAL:** Finish the conjoined edges.
8. Slide Top Strap (C) through the flesh side of the oblong punch on Back Body (A) and align the remaining round holes, secure with Chicago Screws.
9. Slide the Top Strap (C) through the buckle and mark where you want the strap to be secured.
10. Using the provided template, align the center hole with the marked location on Top Strap (C) and punch an oval hole and two on either side.
11. Finish the end of Top Strap (C) to the desired shape and secure the strap through the buckle.

**COMPLETED PROJECT**



FOR MORE PATTERNS, PROJECTS, AND TIPS,  
VISIT [TANDYLEATHER.COM/BLOG](http://TANDYLEATHER.COM/BLOG).

Distributed by Tandy Leather: 1900 SE Loop 820, Fort Worth, TX 76140  
Made in the USA.  
©2024 Tandy Leather: All rights reserved