

DILLON BIFOLD KIT

KIT DE BILLETERA PLEGABLE DILLON
KIT PORTEFEUILLE À DEUX VOILETS DILLON

LEVEL

3

KIT CONTAINS:

Pre-Cut, Pre-Punched Leather
Needles (2)
Thread
Instructions & Pattern



French and Spanish
Instructions available
online at:

TANDYLEATHER.COM
TANDYLEATHER.CA

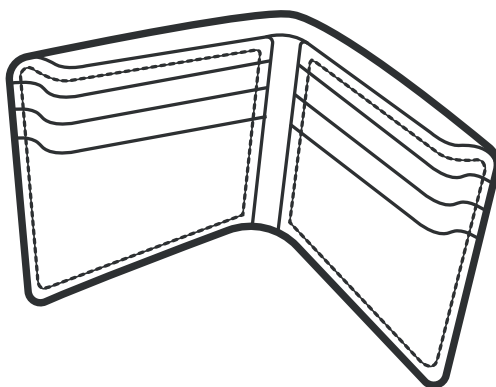

YOU WILL NEED:

• Thread Cutter or Scissors

LEVEL UP WITH TANDY

LEVEL	LEVEL	LEVEL	LEVEL
1	2	3	4
Includes basic project assembly skills with no hand-sewing or hardware setting required. Plus, learn additional skills like lacing, braiding, and knot tying.	Introduces skills like hand-sewing with pre-punched stitching holes, hardware setting, and edge burnishing.	Build your skills with more added components, project layers, and detail work like edge beveling and edge dyeing.	Can be machine or hand sewn and do not have pre-punched stitching holes. Learn new skills like skiving, wet molding, heat creasing, and more.

PLEASE READ ALL INSTRUCTIONS BEFORE BEGINNING PROJECT.

NOTE: ALL STAINING, DYEING, AND TOOLING SHOULD BE DONE PRIOR TO ASSEMBLY

WHAT'S INCLUDED?

Main Body Cover (A)
Main Interior (B)
Left Mid Wall (C)
Right Mid Wall (D)
Left T-Pockets (E)
Right T-Pockets (F)
Left Front Pocket (G)
Right Front Pocket (H)

Not Shown:

Instructions & Pattern

Scan this code with your phone to learn about these skills and more!



SKILLS USED:

Hand Sewing Skills

OPTIONAL TOOLS:

Stitching Horse to hold leather pieces while stitching.
Emery Board to sand edges.
Edge Beveler (Size #1) for edge finishing.
Multi-size Wood Slicker to burnish edges.
Gum Tragacanth for burnishing edges.

GLOSSARY:

FLESH SIDE: The underside of an animal's hide. On veg-tanned tooling leather, this is the rough side.

GRAIN SIDE: The hide's surface that had the hair of the animal. Typically used for carving and stamping.

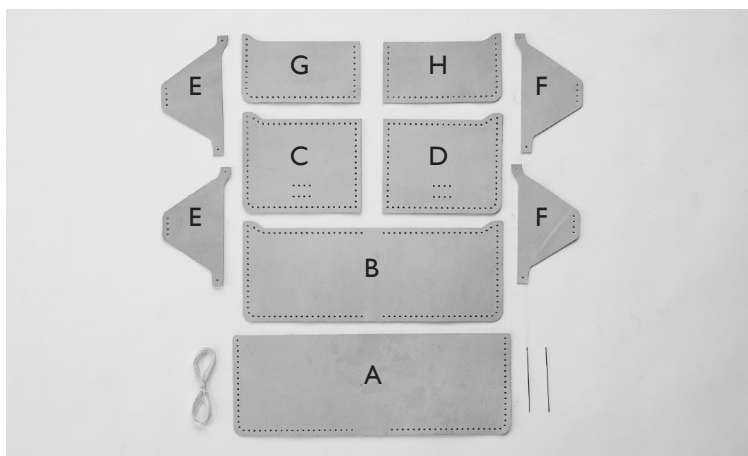

WARNING:

CHOKING HAZARD - Small parts. For adult use only. This product is not intended for use by children. CONTAINS FUNCTIONAL SHARP POINT - Adult supervision recommended.



OPTIONAL: BURNISHING EDGES

NOTE: Burnish all individual pieces before assembling. Then burnish final product to desired results.

1. Rub emery board gently across the edges so that the leather is even and smooth. Dust off. (Figure 1)
2. Use a Q-Tip to gently seal the edges with Eco-Flo® Gum Tragacanth Burnishing Agent. Let air dry. (Figure 2)
3. Burnish edges with a wood slicker: (Figure 3)
4. Repeat steps 2 and 3 until you reach desired outcome.

Figure 1



Figure 2



Figure 3



ATTACHING LEFT SIDE TO BODY

1. Align the four punch holes on Left T-Pocket (E) to the four punch holes on the top row of Left Mid Wall (C). The flesh side of Left T-Pocket (E) should meet the grain side of Left Mid Wall (C).

NOTE: Examples might be inverted as they are secured to a stitching horse.

2. Thread your needles and saddle stitch the four punch holes. (Figures 4-6)

Pro Tip: *Secure your work with a stitching horse. See [Level Up Your Skills on page 9](#) for Details on how to Thread Needle and Saddle Stitch.*

Figure 4

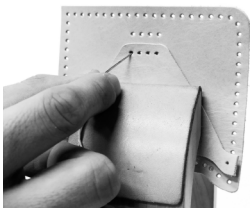

Figure 5

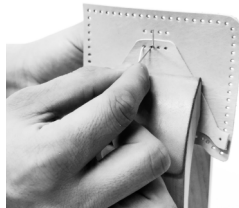
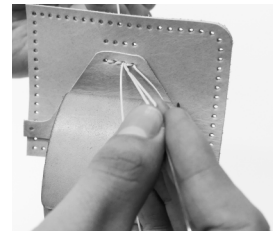

Figure 6



3. Lay the flesh side of the second Left T-Pocket (E) over the first Left T-Pocket (E) you previously sewn. Align the four punch holes from the second Left T-Pocket (E) to the bottom four punch holes on the Left Mid Wall (C) and saddle stitch across. (Figures 7-9)

Figure 7

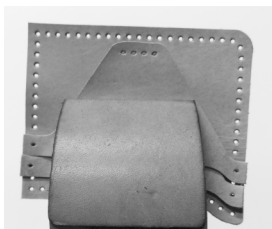

Figure 8

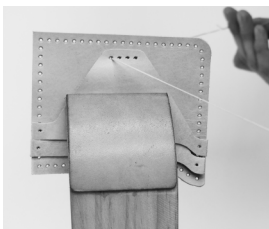

Figure 9



4. Place the Left Front Pocket (G) over the attached Left T-Pockets (E) with the grain side facing up.

5. Starting from the bottom left 90 degree corner, begin saddle stitching through all the pocket layers. Stitch through and connect the Right T-Pockets (F), Right Front Pocket (H), and Right Mid Wall (D). Edge lock stitch off the end of the Right T-Pocket (F). DO NOT stitch through the last stitch hole. (Figures 10-14)

See Level Up Your Skills on page 10 for Details on how to Edge Lock Stitch.

6. Be sure to saddle stitch between each pocket piece and gently pull the thread to minimize any gaps.

Figure 10

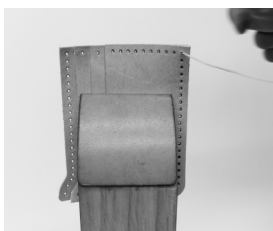

Figure 11

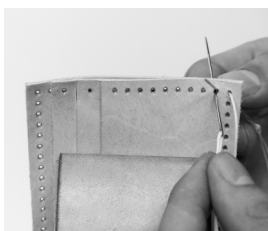

Figure 12



Figure 13

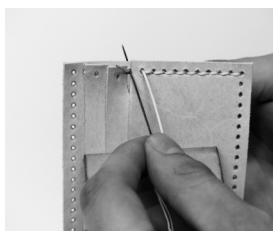
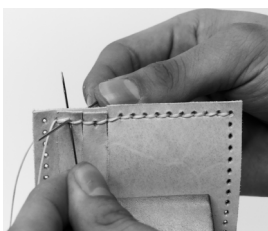

Figure 14



ATTACHING RIGHT SIDE TO BODY

7. Now, you will repeat the above process on the opposite side of the wallet using Mid Wall Right (D), the two Right T-Pockets (F) and the Front Right Pocket (H).

8. Attach Right T-Pocket (F) to Mid Wall Right (D). Starting at the bottom of the Right T-Pocket (F), align the four punch holes to the top row four punch holes on Mid Wall Right (D). Begin to saddle stitch until completely attached to the Mid Wall Right (D).

9. Place the second Right T-Pocket (F) over the first Right T-Pocket so the holes align to the bottom set of four punch holes. Saddle stitch just as you did previously. Be sure all pattern pieces are facing grain side up. (Figures 15-16)

Figure 15

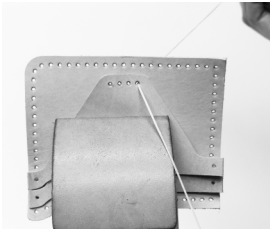
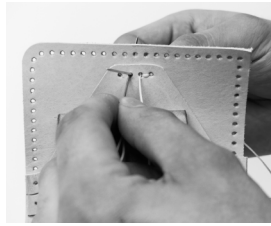

Figure 16



10. Next, take the Right Front Pocket (H) and lay over the attached two Right T-Pockets (F). Starting from the bottom left 90 degree corner, saddle stitch upward to attach the pockets to Mid Wall Right (D). (Figure 17 & 18)

11. You should be stitching through and connecting all three pieces- both Left T-pockets (F) and the Front Right Pocket (H) to the Mid Wall Left (D). Be sure to stitch between each pocket piece. When you come to the end of the stitch line you will edge lock stitch off Right T-Pocket (F) onto Mid Wall Right (D).

NOTE: the top stitch hole should not be stitched at this time.

Figure 17

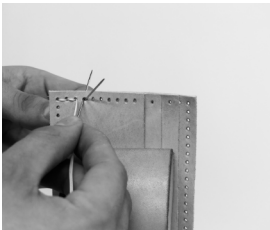
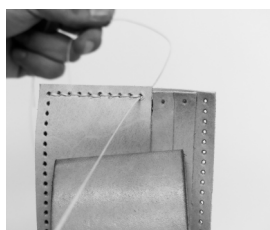

Figure 18



ATTACHING POCKETS TO MAIN INTERIOR

12. Once both left and right pocket pieces are assembled, take the assembled left pocket pieces, and align the holes so they are even over the Main Interior (B). The flesh side of the left pocket meets the grain side of Main Interior (B). (Figure 19)

13. Starting from the top left corner, saddle stitch left pockets to Main Interior (B). (Figure 20-21) Be sure to stitch the top row only. Saddle stitch across and end with an Edge Lock Stitch. (Figure 22 & 23)

14. Repeat this process for the assembled right-hand pockets (D, F & H).

Figure 19

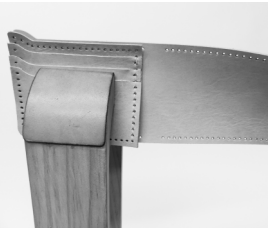

Figure 20

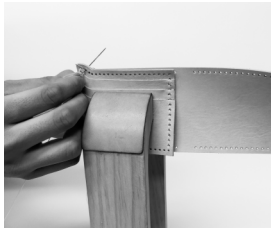

Figure 21

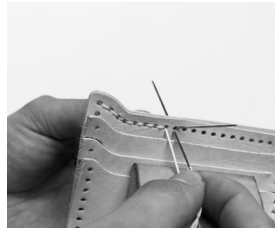

Figure 22

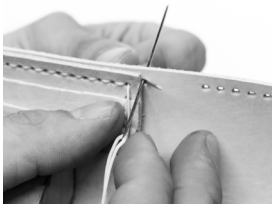
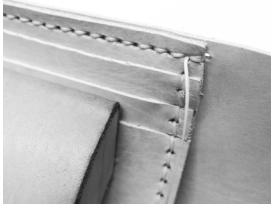

Figure 23



ATTACHING MAIN BODY COVER TO INTERIOR

15. Place Main Body Cover (A) flesh side up. Place Main Interior (B) over the Main Body Cover so that flesh sides meet. Align the stitch holes. *Optional:* Starting from the top right corner; Edge Lock Stitch off the edges of the Main Body Cover (A) and Main Interior (B).

16. Continue clockwise. Securing the Main Body Cover (A) with Main Interior (B) and the right side pockets. (Figures 24-28)

17. Finish by sewing off the edge of the Main Interior (B) to the last hole on the Main Cover (A) and back stitching. (Figure 29)

18. Repeat above steps for the left side of Main Interior (B). Be sure to align the punch holes and start from the top left corner.

Figure 24



Figure 25



Figure 26



Figure 27

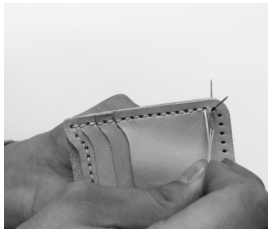

Figure 28



Figure 29



19. Once Main Cover (A) and Main Interior (B) are secured and assembled, optional to burnish remaining edges to the desired outcome. (Figure 30-32)

Figure 30



Figure 31



Figure 32



**CONGRATULATIONS, YOU'VE MADE
A DILLON BIFOLD!**



* Images are for constructions purposes only. Colors may vary.

LEVEL UP YOUR SKILLS WITH TANDY

HOW TO THREAD YOUR NEEDLES:

1. Cut your thread to 5 times the length of the seam you are sewing and feed one end through the eye of one needle, moving over to the opposite end of the thread. Repeat step 1 for the second needle. (Figure 1)
2. Take the point of your needle and push it through the longer portion of the thread. Once the needle is all the way through, give a gentle tug to lock thread into place. (Figure 2)
3. Repeat Step 2 with the second needle. There should now be a knot behind both needles to secure the thread in place as you are stitching. (Figure 3)

Figure 1



Figure 2



Figure 3

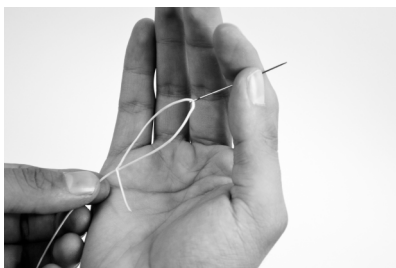

HOW TO EDGE LOCK STITCH:

An edge lock stitch joins two separate pieces of material over a flat edge to prevent unravelling and can be used at the start or end of a saddle stitch.

1. Insert one of the threaded needles through the first hole. Pull the needle through until there are equal lengths of thread on either side.
2. Take one of the needles and make a loop that goes around the outside edge of leather. Insert the opposing needle through the opposite side to close the loop. (Figure 1)
3. Resume saddle stitching as normal. (Figure 2)
4. To finish with an edge lock stitch, reverse your needles and place them back through the last stitch hole. Making a loop that goes around the outside edge of leather.
5. Another example of an edge lock stitch can be used when all edges are flush and the thread loop goes around the outside edge of all layers of leather. (Figure 3)

Figure 1



Figure 2

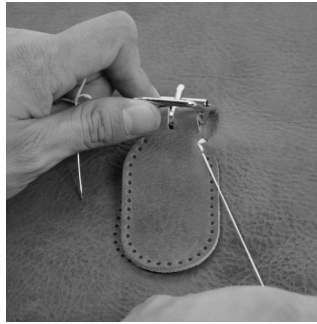

Figure 3



HOW TO SADDLE STITCH:

The saddle stitch is a strong stitch that is made up of two independent stitches that lock together. This allows the stitches to hold even if a stitch is broken.

1. Thread your needles with a length of thread that is 5x the length of the line you are stitching. *Tip: Use a Stitching Horse to secure your pieces in place and allow for easier sewing.*

2. Holding one threaded needle in each hand, begin saddle stitching by inserting one needle into the first hole of your stitching line. Pull the needle and thread through the hole until you have equal lengths of thread on either side. (Figure 1)

3. With one needle in each hand, begin weaving the needles through the next stitch hole, one needle at a time. It is important to be consistent with your motions, always starting each stitch with the same hand. *We will start with the left-hand needle for each stitch for these instructions.* Push the left needle through next hole in your stitch line.

4. Once the left needle is through the hole, insert your right-hand needle through the same hole, being sure to pull the left thread back to avoid piercing it with the right needle. Pull the thread from both needles all the way through the hole and give the thread a gentle tug to tighten up the stitches. (Figure 2)

Optional: If your stitch holes are large enough, you can insert your needles in the same hole at the same time. Cross your needles into an "X" as you push them through the hole. Be sure to always place the same side needle on the top and bottom for each stitch, then pull the needles through and tighten up the thread with a gentle tug.

5. Repeat Steps 3-4 until you reach the end of your stitch line, starting with the same side needle for each stitch. Be sure to give the thread a light tug at the end of each stitch to keep even tension.

Figure 1

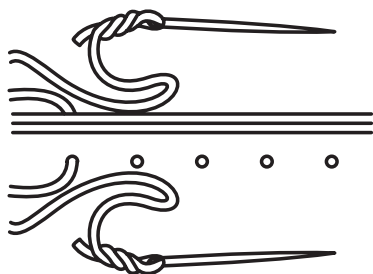
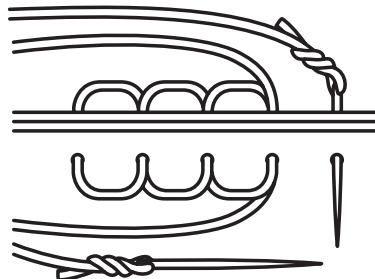

Figure 2





FOR MORE PATTERNS, PROJECTS, AND TIPS,
VISIT [TANDYLEATHER.COM/BLOG](https://www.tandy.com/blog).

Distributed by Tandy Leather: 1900 SE Loop 820, Fort Worth, TX 76140
Made in the USA with global components.
©2022 Tandy Leather. All rights reserved