

LEVEL

3

# FLORA WALLET KIT

KIT DE BILLETERA FLORA  
TROUSSE PORTEFEUILLE FLORA

### KIT CONTAINS:

Pre-Cut, Pre-Punched Leather  
Needles (2)  
Thread  
Instructions & Pattern



French and Spanish  
Instructions available  
online at:

**TANDYLEATHER.COM**  
**TANDYLEATHER.CA**

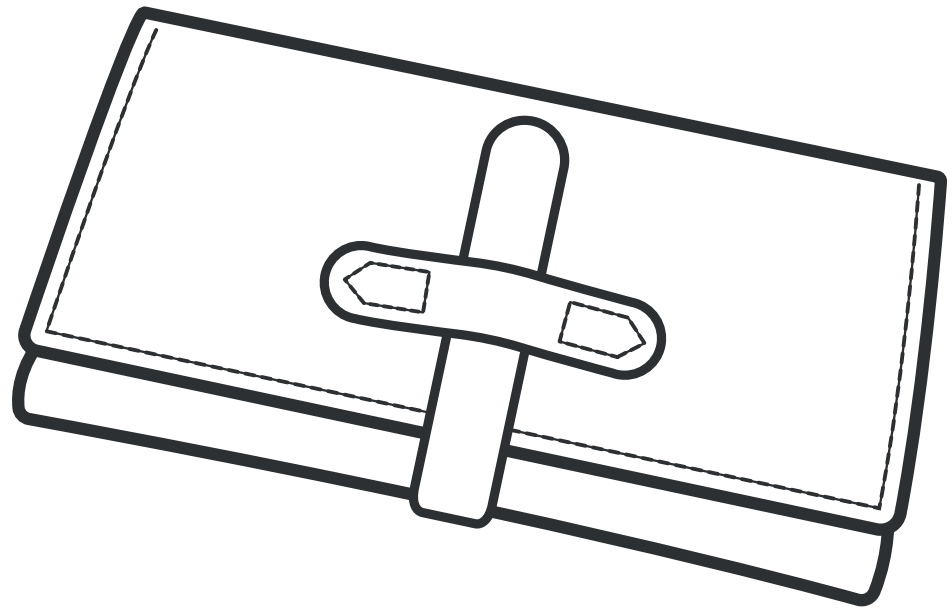

### YOU WILL NEED:

- Thread Cutter or Scissors

## LEVEL UP YOUR SKILLS WITH TANDY

LEVEL	LEVEL	LEVEL	LEVEL
1	2	3	4
Includes basic project assembly skills with no hand-sewing or hardware setting required. Plus, learn additional skills like lacing, braiding, and knot tying.	Introduces skills like hand-sewing with pre-punched stitching holes, hardware setting, and edge burnishing.	Build your skills with more added components, project layers, and detail work like edge beveling and edge dyeing.	Can be machine or hand sewn and do not have pre-punched stitching holes. Learn new skills like skiving, wet molding, heat creasing, and more.



**WARNING:**

CHOKING HAZARD - Small parts. For adult use only. This product is not intended for use by children. CONTAINS FUNCTIONAL SHARP POINT - Adult supervision recommended.

# PLEASE READ ALL INSTRUCTIONS BEFORE BEGINNING PROJECT.

**NOTE:** ALL STAINING, DYEING, AND TOOLING SHOULD BE DONE PRIOR TO ASSEMBLY

## WHAT'S INCLUDED?

Main Body (A)  
Exterior Pocket (B)  
Interior Base (C)  
Interior Front Pocket (D)  
Card Pocket (E)  
T-Pocket (F)  
Gussets (G)  
Strap (H)  
Keeper (I)  
Needles  
Thread

## Not Shown:

Instructions & Pattern

## SKILLS USED:

Backstitch  
Edge Lock Stitch  
Saddle Stitch



*Scan this code with your phone to learn about these skills and more!*

## RECOMMENDED TOOLS:

Stitching Horse to hold leather pieces while stitching.  
Emery Board to sand edges.  
Multi-size Wood Slicker to burnish edges.  
Eco-Flo® Gum Tragacanth to burnish edges.  
Cotton Swab to apply burnishing solution.

## GLOSSARY:

**FLESH SIDE:** The underside of an animal's hide. On veg-tanned tooling leather, this is the rough side.

**GRAIN SIDE:** The hide's surface that had the hair of the animal. Typically used for carving and stamping.

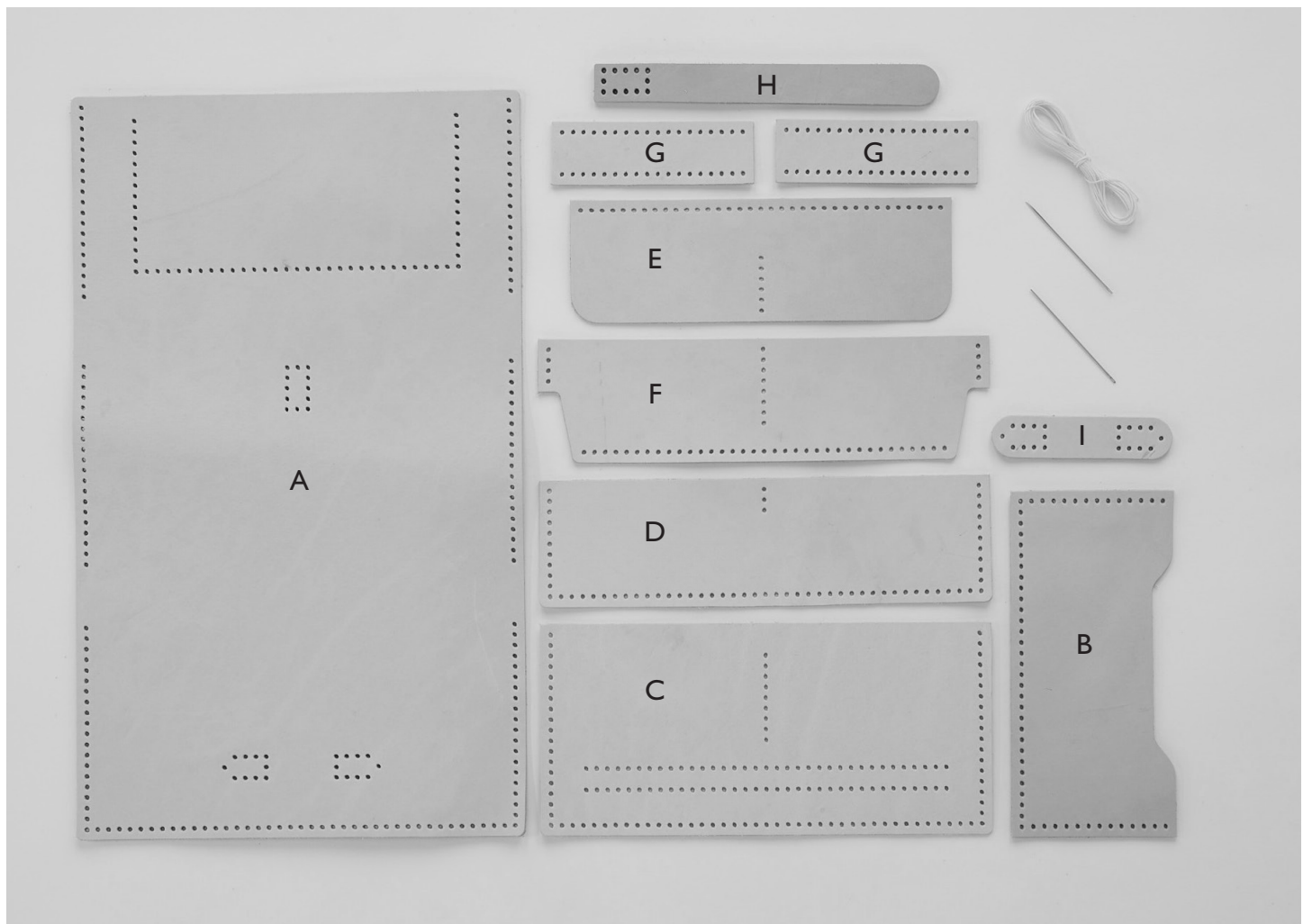

## OPTIONAL: BURNISHING EDGES

**NOTE:** Burnish all individual pieces before assembling. Then burnish final product to desired results.

1. Rub emery board gently across the edges so that the leather is even and smooth. Dust off. (Figure 1)
2. Use a cotton sawb to gently seal the edges with Eco-Flo® Gum Tragacanth Burnishing Agent. Let air dry. (Figure 2)
3. Burnish edges with a wood slicker: (Figure 3)
4. Repeat steps 2 and 3 until you reach desired outcome.

Figure 1

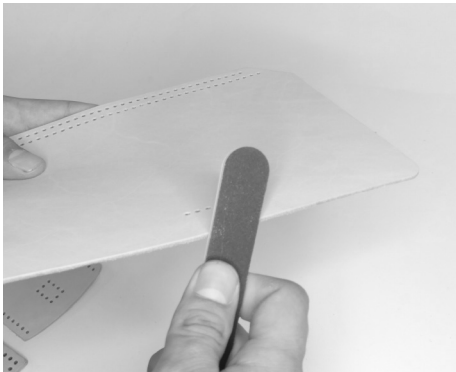

Figure 2

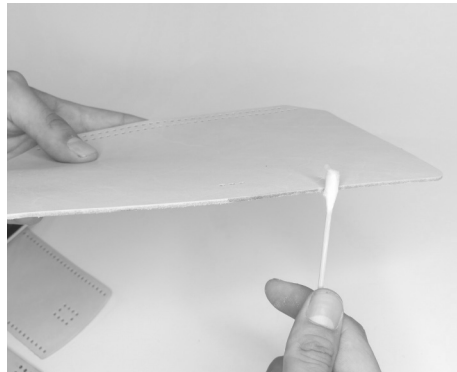
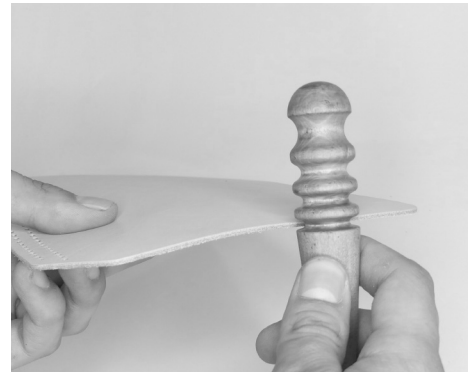

Figure 3



## ATTACHING EXTERIOR POCKET TO MAIN BODY

1. Align the pre-punched holes of the Exterior Pocket (B) and Main Body (A). The flesh side of the Exterior Pocket (B) should be facing the grain side of Main Body (A).
2. Use threaded needles on the right-hand side to edge lock stitch to secure. Then saddle stitch clockwise until completed. (Figures 4-11) **Pro Tip: Secure your work with a stitching horse. See Level Up Your Skills on page 14 for Details on how to Thread a needle, Edge Lock Stitch, and Saddle Stitch.**
3. Complete an edge lock stitch to secure Exterior Pocket (B) to the Main Body (A). (Figure 12-13)

Figure 4

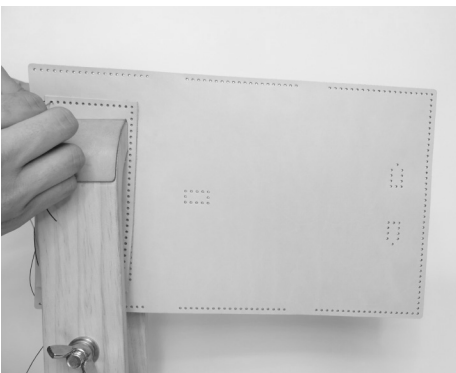

Figure 5

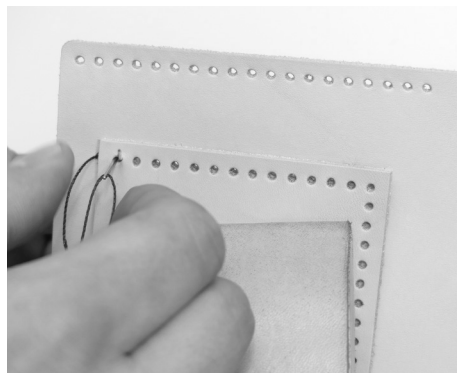

Figure 6

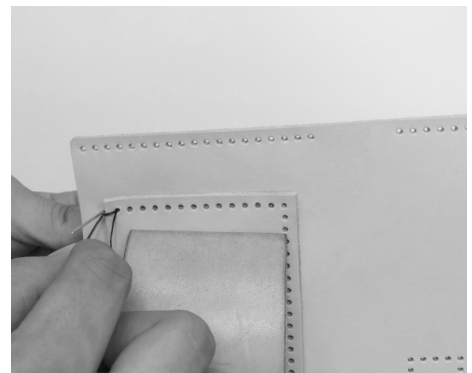

Figure 7

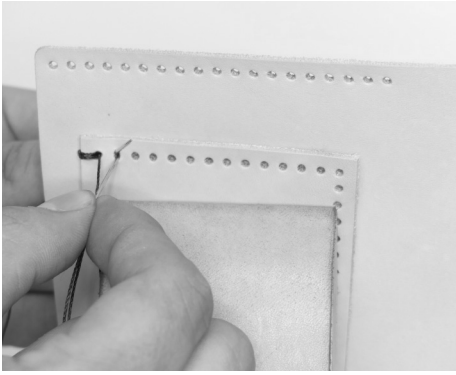

Figure 8

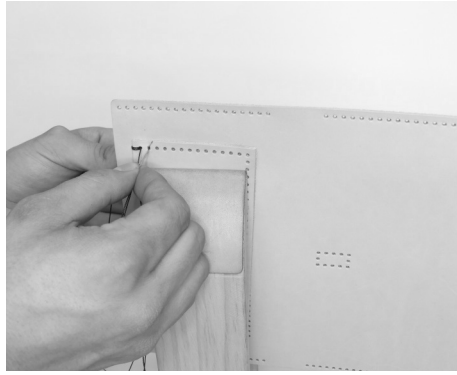

Figure 9

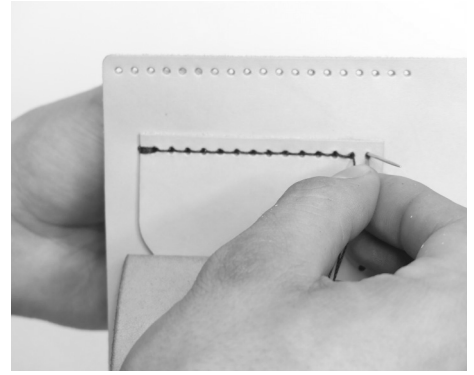

Figure 10

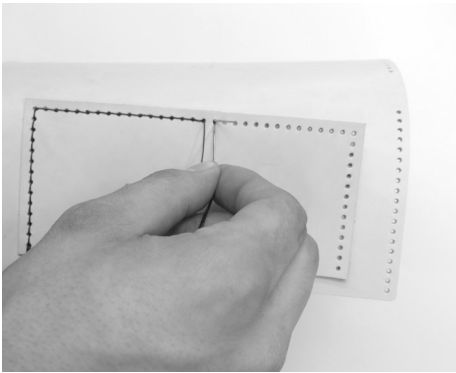

Figure 11

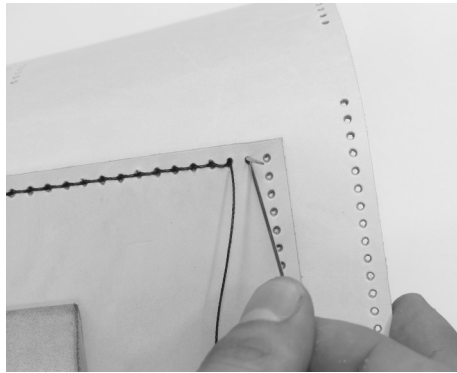

Figure 12

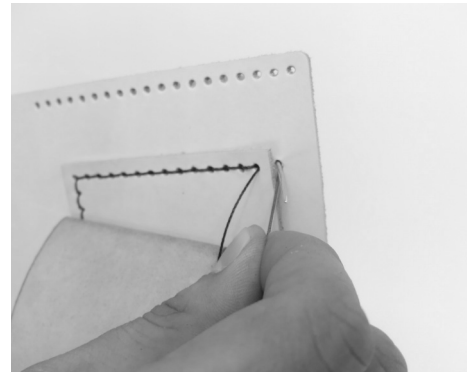
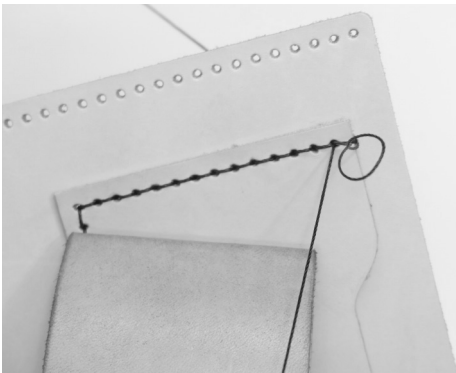

Figure 13



## ATTACHING KEEPER TO MAIN BODY

4. Align Keeper (I) with the pre-punched holes on the Main Body (A). The flesh side of the Keeper (I) should be facing the grain side of the Main Body (A). (Figure 14)
5. Saddle stitch from the center of the Keeper (I) until the first side to the Main Body (A) is completely attached. Finish by stitching over 1-2 stitch holes to secure. (Figures 15-16)
6. Repeat the steps 4-5 on the other side of the Keeper (I). (Figure 17)

Figure 14

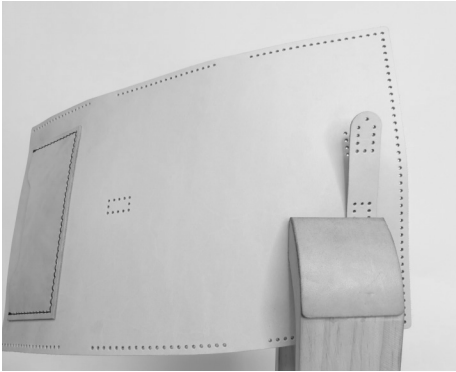

Figure 15

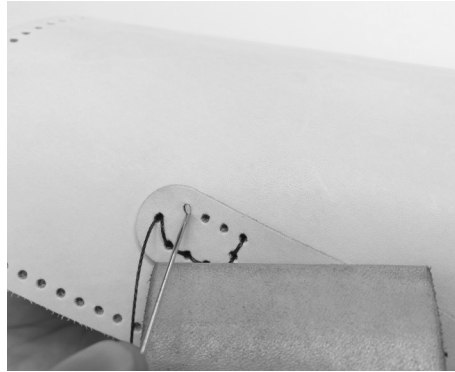

Figure 16

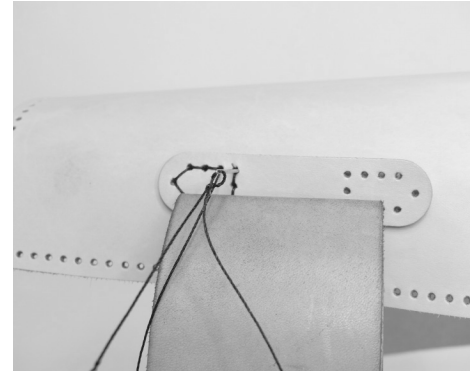
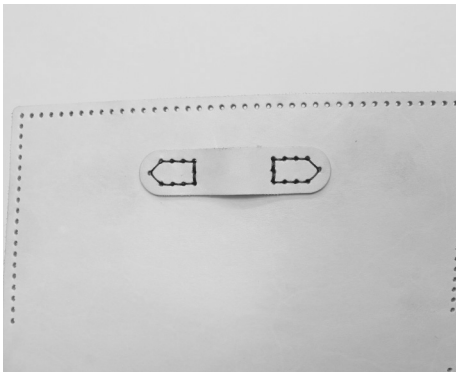

Figure 17



## ATTACHING STRAP TO MAIN BODY

7. Taking the Strap (H), align the pre-punched holes with those on the Main Body (A). The strap should be laying over the Exterior Pocket (B) with the flesh side of the Strap (H) against the grain side of the Main Body (A).

8. Starting from the bottom row of holes, take threaded needles and saddle stitch all the way around so the Strap (H) is completely attached to the Main Body (A). Stitch over first 1-2 holes to secure your stitch line. (Figures 18-19)

Figure 18



Figure 19

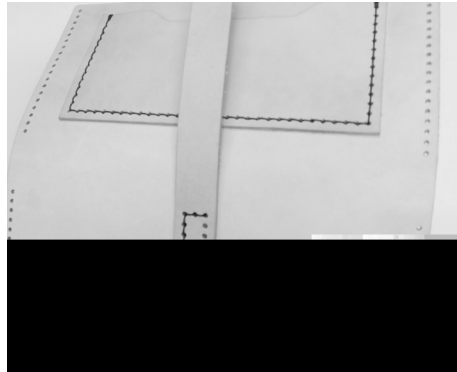

## ATTACHING T-POCKET TO INTERIOR BASE

9. Align the pre-punched holes of the T-Pocket (F) to the pre-punched holes on the Interior Base (C). The flesh side of the T-Pocket (F) should be facing the grain side of the Interior Base (C). (Figure 20)

10. Using threaded needles, saddle stitch across the bottom, horizontal row of the T-Pocket (F), attaching it to the 3<sup>rd</sup> row from the bottom of the Interior Base (C). Backstitch 2-3 stitches to secure. (Figures 21-23) **See Level Up Your Skills on page 15 for Details on how to Backstitch.**

Figure 20

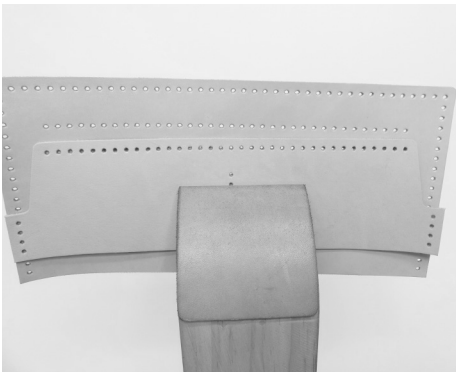

Figure 21

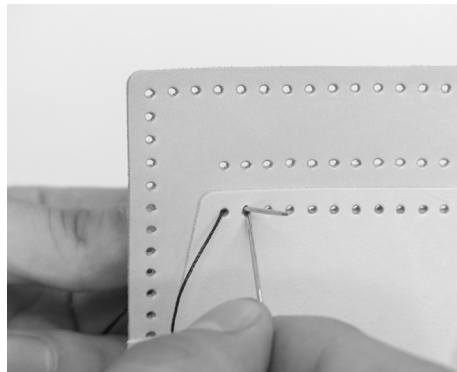

Figure 22

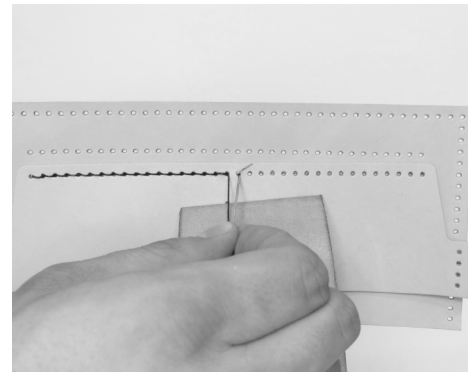
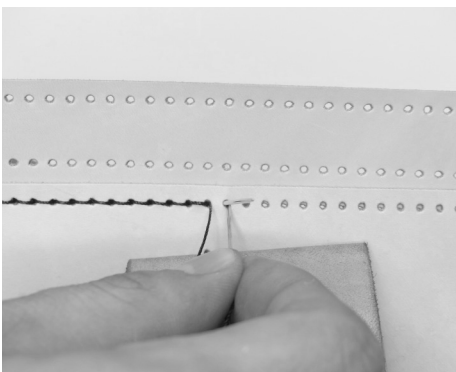

Figure 23



## ATTACHING CARD POCKET TO INTERIOR BASE

11. Align the pre-punched holes of Card Pocket (E) with the pre-punched holes on the Interior Base (C). The flesh side of the Card Pocket (E) should be facing the grain side of the Interior Base (C) and should lay over the attached T-Pocket (F).

12. Using threaded needles, saddle stitch across the 2<sup>nd</sup> row of holes. (Figure 24-28)

Figure 24

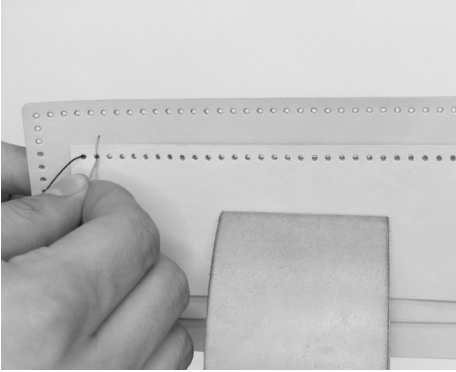

Figure 25

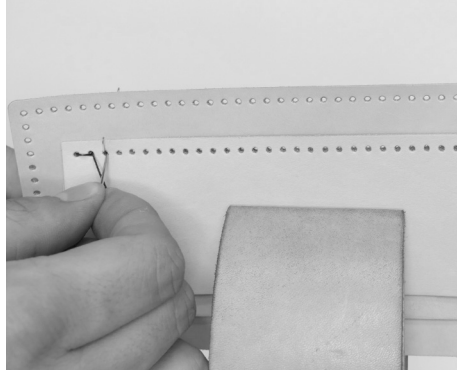

Figure 26

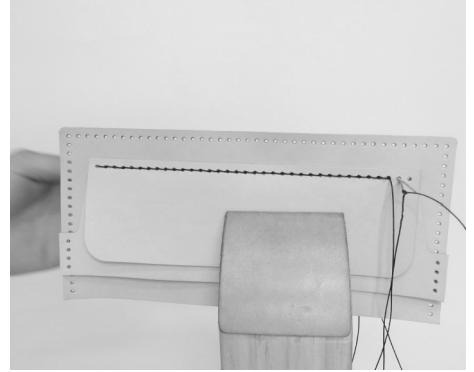

Figure 27

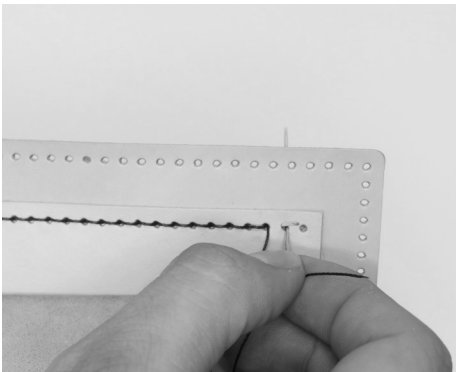

Figure 28





## ATTACHING INTERIOR FRONT POCKET TO INTERIOR BASE AND ASSEMBLED CARD/ T-POCKET

13. Taking the assembled Card Pocket/T-Pocket pieces, align the pre-punched holes of the Interior Base (C) onto the Interior Front Pocket (D) so the three middle holes on the Interior Front Pocket (D) line up with the three bottom holes of the Card Pocket (E). (Figure 29)

14. Using threaded needles, saddle stitch through the center row of holes connecting the Interior Base (C), Front Pocket (D) and assembled Card/T-Pocket. (Figures 30-32)

Figure 29

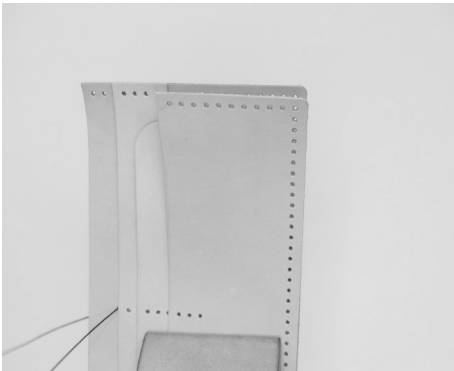

Figure 30

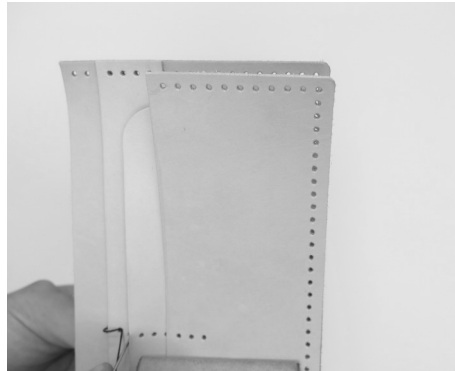

Figure 31

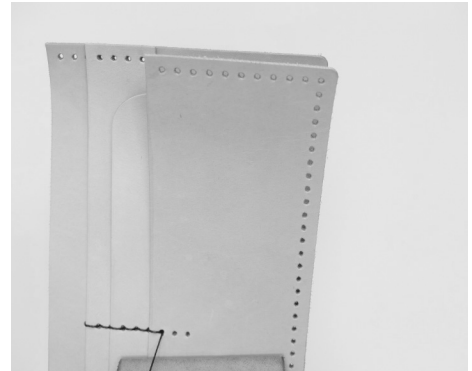
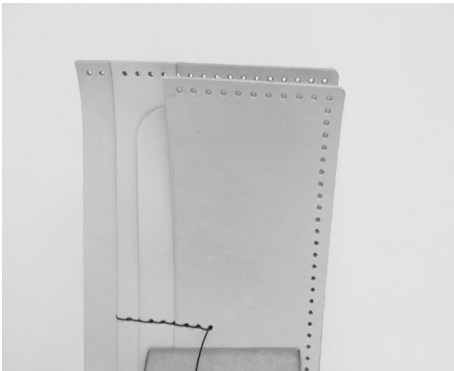

Figure 32



## ATTACHING ASSEMBLED INTERIOR POCKETS TO MAIN BODY

15. Taking assembled interior pockets align the pre-punched holes on the flesh side of Main Body (A). Align them on the Keeper (I) side of the wallet. Be sure flesh sides meet.

16. Using threaded needles start with an edglock stitch (Figure 33). Continue saddle stitching all the way around until pockets are completely attached to the Main Body (A). (Figures 34-37)

17. Finish with an edglock stitch to secure.

Figure 33



Figure 34



Figure 35

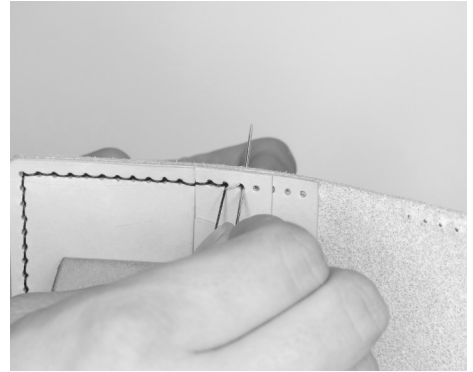

Figure 36

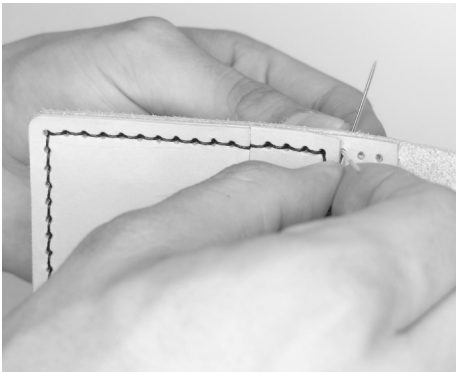
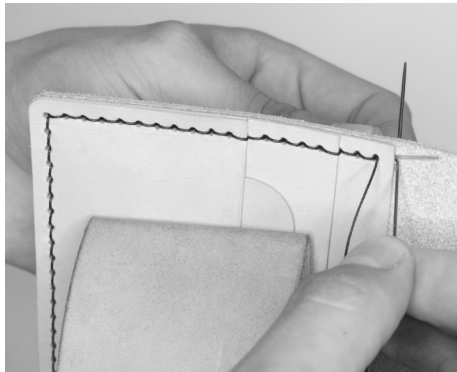

Figure 37



## ATTACHING GUSSETS TO THE INTERIOR MAIN BODY

18. Align the pre-punched holes of Gusset (G) to the center outer edge stitch line on Main Body (A). Flesh sides should meet. There should be one punch hole on either side of Gusset (G) for an edge lock stitch. (Figure 38)

19. Using threaded needles, start by edglock stitching the Gusset (G) through the first two holes of the Main Body (A) to secure. (Figure 39)

20. Continue across the row of pre-punched holes until you reach the end. Secure with an edglock stitch. (Figures 40-43)

21. Next, take the second Gusset (G) and repeat steps 18-20. Make sure to edglock stitch at the beginning and the end to secure the Gusset (G) tightly to the Main Body (A).

22. Fold over the side of Main Body (A) with the Exterior Pocket (B) so the pre-punched holes on the Gusset (G) (that you have not sewn through) align with the holes on the Main Body (A). (Figure 44)

23. With threaded needles, edglock stitch through the first holes and then continue with a saddle stitch till the end. Finish with an edglock to secure. (Figures 45-48)

24. Next, secure the other Gusset (G).

Figure 38

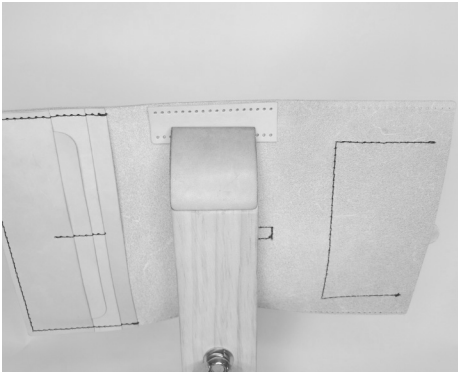

Figure 39

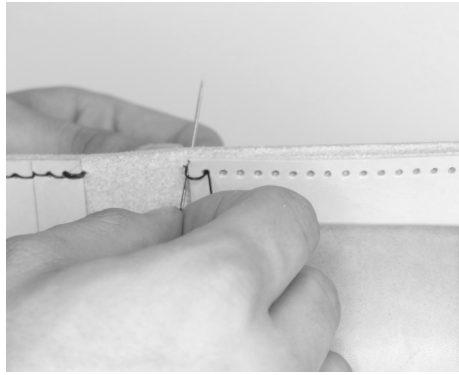

Figure 40

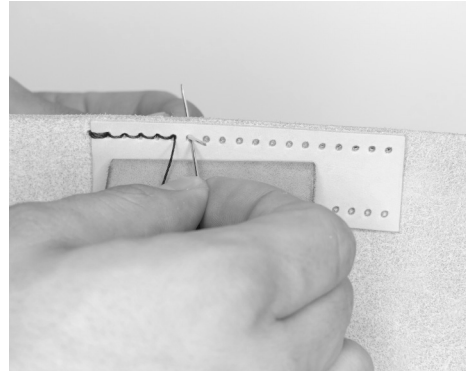

Figure 41

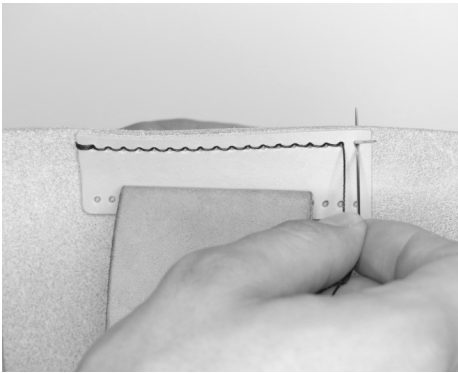

Figure 42

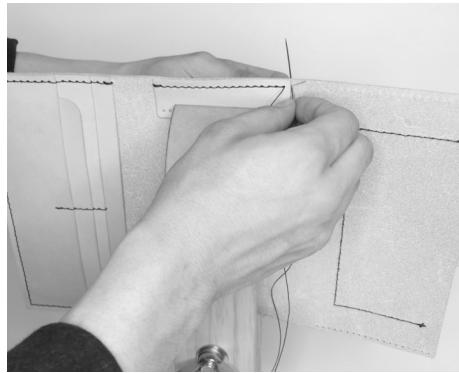

Figure 43

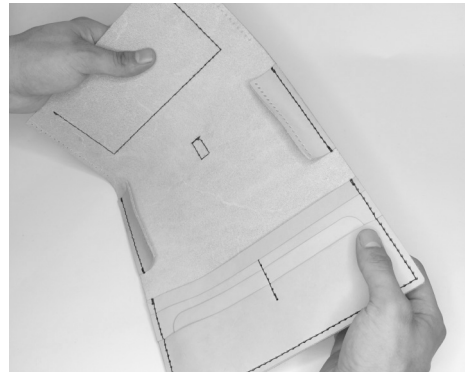

Figure 44



Figure 45

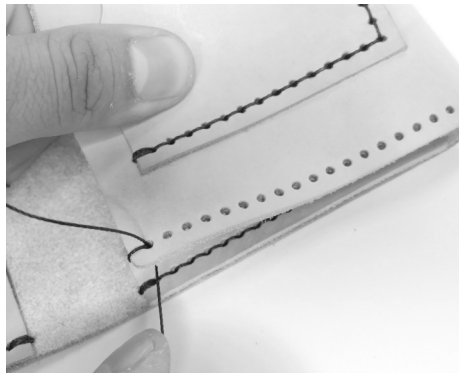

Figure 46

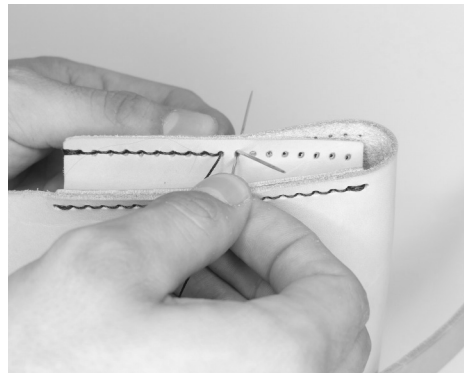

Figure 47

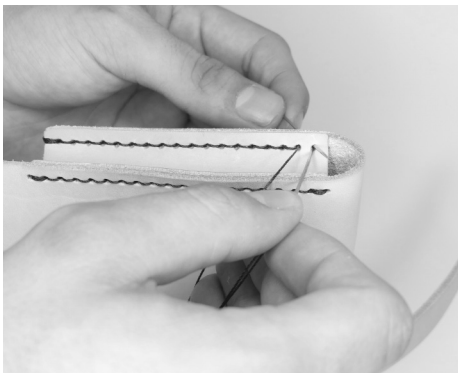
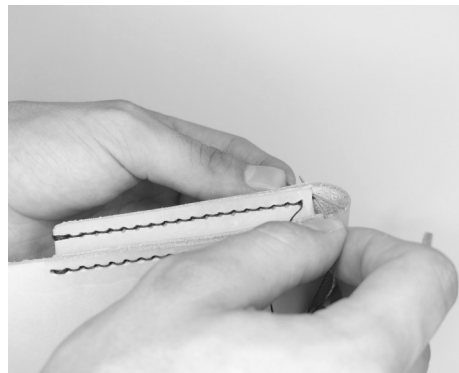

Figure 48



## OPTIONAL: FINISHING YOUR WALLET

25. Now that your wallet is completely assembled, smooth out any rough edges with your emery board. Dust off any loose particles. (Figure 49)

26. Taking your cotton swab apply a small amount of Eco-Flo Gum to seal the edges. Let dry for 5 minutes. (Figure 50)

27. Rub edges with a wood slicker to polish and smooth edges. (Figure 51)

28. Repeat this process until desired outcome is achieved.

Figure 49

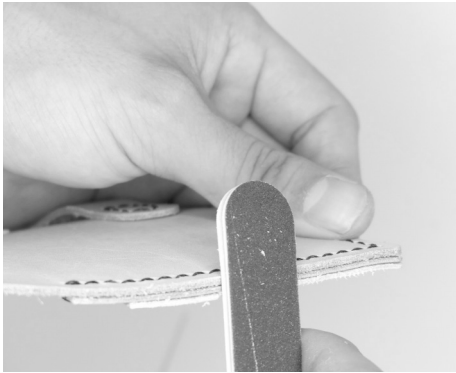

Figure 50

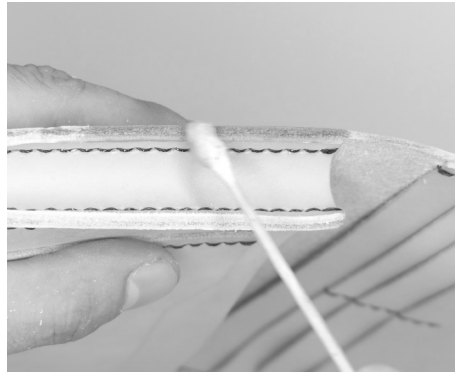
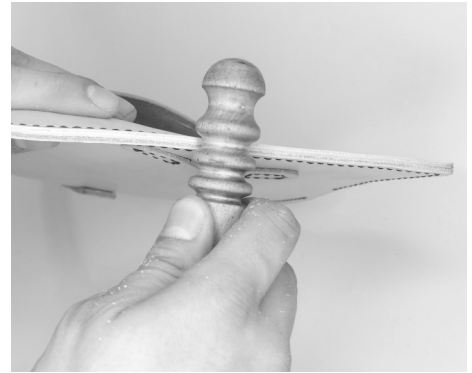

Figure 51



**CONGRATULATIONS, YOU'VE MADE A FLORA WALLET!**



\* Images are for construction purposes only. Colors may vary.

# LEVEL UP YOUR SKILLS WITH TANDY!

## HOW TO THREAD YOUR NEEDLES:

1. Cut your thread to 5 times the length of the seam you are sewing and feed one end through the eye of one needle, moving over to the opposite end of the thread. Repeat step 1 for the second needle. (Figure 1)
2. Take the point of your needle and push it through the longer portion of the thread. Once the needle is all the way through, give a gentle tug to lock thread into place. (Figure 2)
3. Repeat Step 2 with the second needle. There should now be a knot behind both needles to secure the thread in place as you are stitching. (Figure 3)

Figure 1



Figure 2



Figure 3



## HOW TO EDGE LOCK STITCH:

An edge lock stitch joins two separate pieces of material over a flat edge to prevent unraveling and can be used at the start or end of a saddle stitch.

1. Insert one of the threaded needles through the first hole. Pull the needle through until there are equal lengths of thread on either side.
2. Take one of the needles and make a loop that goes around the outside edge of leather. Insert the opposing needle through the opposite side to close the loop. (Figure 1)
3. Resume saddle stitching as normal. (Figure 2)
4. To finish with an edge lock stitch, reverse your needles and place them back through the last stitch hole. Making a loop that goes around the outside edge of leather:
5. Another example of an edge lock stitch can be used when all edges are flush and the thread loop goes around the outside edge of all layers of leather. (Figure 3)

Figure 1



Figure 2



Figure 3



## HOW TO SADDLE STITCH:

The saddle stitch is a strong stitch that is made up of two independent stitches that lock together. This allows the stitches to hold even if a stitch is broken.

1. Thread your needles with a length of thread that is 5x the length of the line you are stitching. *Tip: Use a Stitching Horse to secure your pieces in place and allow for easier sewing*
  2. Holding one threaded needle in each hand, begin saddle stitching by inserting one needle into the first hole of your stitching line. Pull the needle and thread through the hole until you have equal lengths of thread on either side. (Figure 1)
  3. With one needle in each hand, begin weaving the needles through the next stitch hole, one needle at a time. It is important to be consistent with your motions, always starting each stitch with the same hand. *We will start with the left-hand needle for each stitch for these instructions.* Push the left needle through next hole in your stitch line.
  4. Once the left needle is through the hole, insert your right-hand needle through the same hole, being sure to pull the left thread back to avoid piercing it with the right needle. Pull the thread from both needles all the way through the hole and give the thread a gentle tug to tighten up the stitches. (Figure 2)
- Optional: If your stitch holes are large enough, you can insert your needles in the same hole at the same time. Cross your needles into an "X" as you push them through the hole. Be sure to always place the same side needle on the top and bottom for each stitch, then pull the needles through and tighten up the thread with a gentle tug.*
5. Repeat Steps 3-4 until you reach the end of your stitch line, starting with the same side needle for each stitch. Be sure to give the thread a light tug at the end of each stitch to keep even tension.

Figure 1

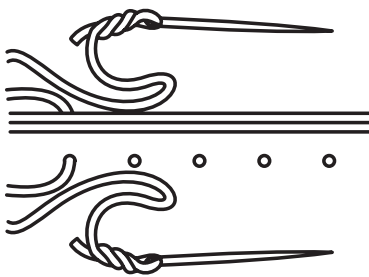
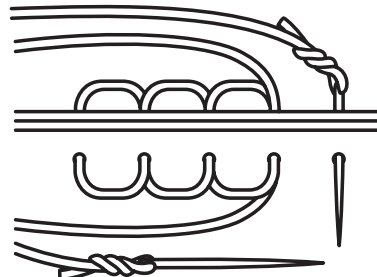

Figure 2



## HOW TO BACKSTITCH:

1. When you reach the final hole in your stitch line, reverse the direction of your needles and saddle stitch back through the last 2-3 holes in your line. If your stitch line meets back where the line began, you can simply saddle stitch over your first 2-3 stitches without reversing the direction of your needles to lock them in. *Tip: It may be tighter to get the needles through the holes that have already been stitched, you can use a pair of needle nose pliers to help pull the needles through if needed.* (Figures 1-3)
2. To finish, pull the remaining thread to the less visible side of your work, snip off the excess then tuck it into the last hole.

Figure 1



Figure 2



Figure 3

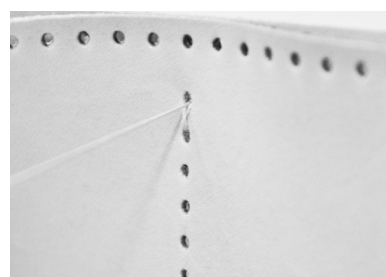



FOR MORE PATTERNS, PROJECTS, AND TIPS,  
VISIT [TANDYLEATHER.COM/BLOG](https://www.tandy.com/blog).

Distributed by Tandy Leather 1900 SE Loop 820, Fort Worth, TX 76140  
Made in the USA with global components.  
©2022 Tandy Leather. All rights reserved