





**TheSouthTrack**  
change your north



# Bajaj Pulsar UG 180, 200, 220 - Soporte Maletas lateral

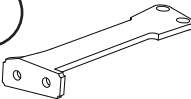
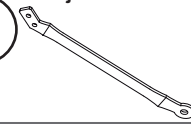
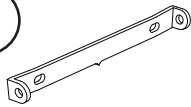

 4-5-6-8 mm

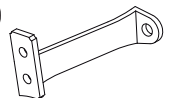
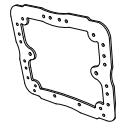
 10-13-17 mm

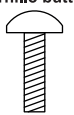
<p><b>1</b> Platina agarraderas</p>  <p>Cantidad - 2 Ubicación Der. Izq.</p>	<p><b>2</b> Anclaje inferior</p>  <p>Cantidad - 2 Ubicación Der. Izq.</p>	<p><b>3</b> Soporte placa</p>  <p>Cantidad - 1 Ubicación Centro</p>
--	--	--

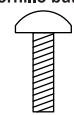
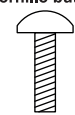
<p><b>4</b> Extensión placa</p>  <p>Cantidad - 2 Ubicación Der. Izq.</p>	<p><b>5</b> Marco</p>  <p>Cantidad - 2 Ubicación Centro</p>
--	--

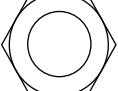
<p><b>A</b> Tornillo button</p>  <p>Cantidad - 1 Medidas 10 x 30 mm</p>	<p><b>B</b> Tuerca de seguridad</p>  <p>Cantidad - 1 Medidas 10 mm</p>	<p><b>C</b> Tornillo butt on</p>  <p>Cantidad - 2 Medidas 8 x 20 mm</p>	<p><b>D</b> Tornillo button</p>  <p>Cantidad - 12 Medidas 6 x 16 mm</p>
--	---	--	--

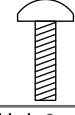
<p><b>E</b> Buje</p>  <p>Cantidad - 2 Medidas 8 x 4.5 x 17</p>	<p><b>F</b> Tuerca de seguridad</p>  <p>Cantidad - 14 Medidas 6 mm</p>	<p><b>G</b> Tuerca de seguridad</p>  <p>Cantidad - 2 Medidas 8 mm</p>	<p><b>H</b> Tornillo button</p>  <p>Cantidad - 2 Medidas 6 x 20 mm</p>
--	---	--	---

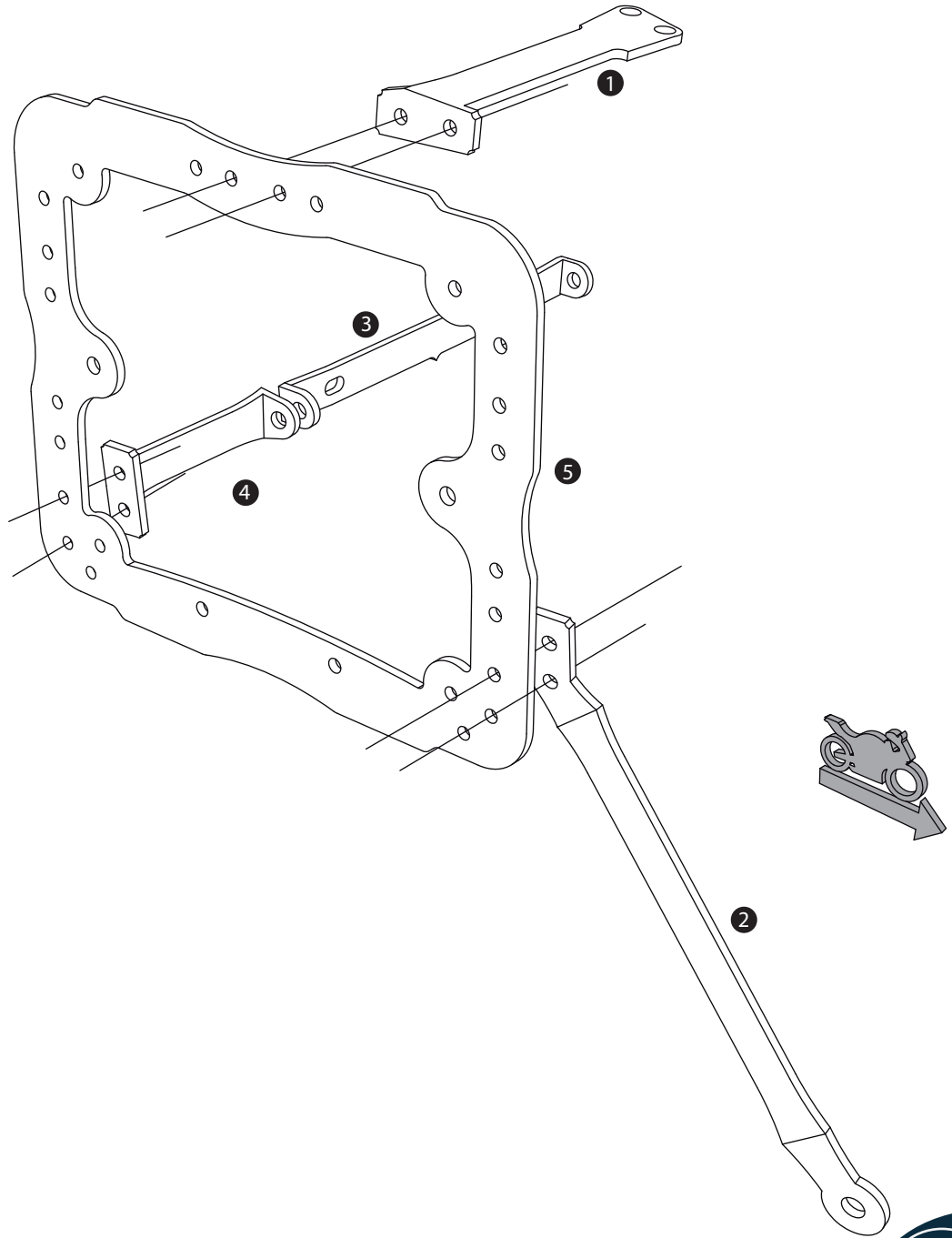

## Instalación

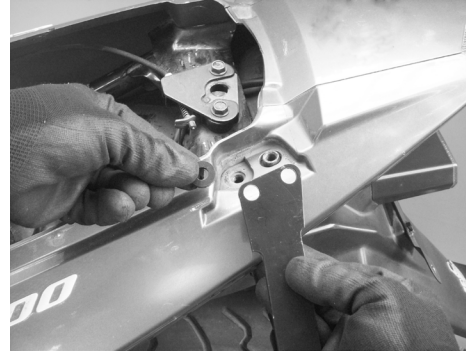

**1-** Soltar las agarraderas originales de la moto y ubicar la platina "agarraderas" (1), asegurándose de poner el buje (E) de tal manera que quede entre la platina y la moto. asegurar esta platina haciendo uso de los tornillos originales de la moto.



**3-** Ubicar la platina "porta placa" en el espacio de la placa de la moto, haciendo uso de los tornillos suministrados (H) y las tuercas (F).

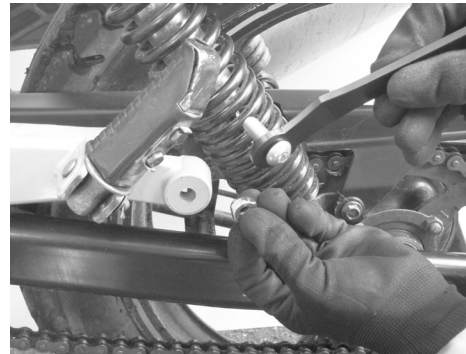

**2-** Poner la platina "inferior" (2) en el anclaje del mofle (al lado derecho) y a la perforación vacía al lado izquierdo. En el lado derecho hacer uso del tornillo original que sostiene el mofle y en el lado izquierdo hacer uso del tornillo suministrado (A) y la tuerca (B).



**4-** Luego ubicar la platina "extensión placa" de la platina porta placas, haciendo uso de los tornillos suministrados (C) y las tuerca (G).

**5-** Finalmente poner el marco (6) de todas las platinas previamente puestas, haciendo uso de los tornillos (D) y las tuercas (F).

### Tener en cuenta

Durante el pre-ensamble apretar los tornillos solo con la mano y una vez montado en la moto comenzar a ajustar todos los tornillos con la herramienta adecuada.

Cada 3.000 km hacer una revisión y ajuste de los tornillos del sistema.

Producto de alto impacto. No se aceptan reclamos posteriores a caídas.