



TheSouthTrack
change your north

Protector de carcasa izquierda - Yamaha MT 09

Tener en cuenta

Durante el **pre-ensamble** apretar los tornillos solo con la mano y una vez montado en la moto comenzar a **ajustar todos los tornillos con la herramienta** necesaria.

Cada 3.000 km hacer una revisión y ajuste de los tornillos del sistema.

Warning

During the mounting process put the bolts and nuts with the hand strength. Then finish the mounting using the right tools.

It is recommended to check the strength of the screws and nuts every 3,000km - 1,500 miles.

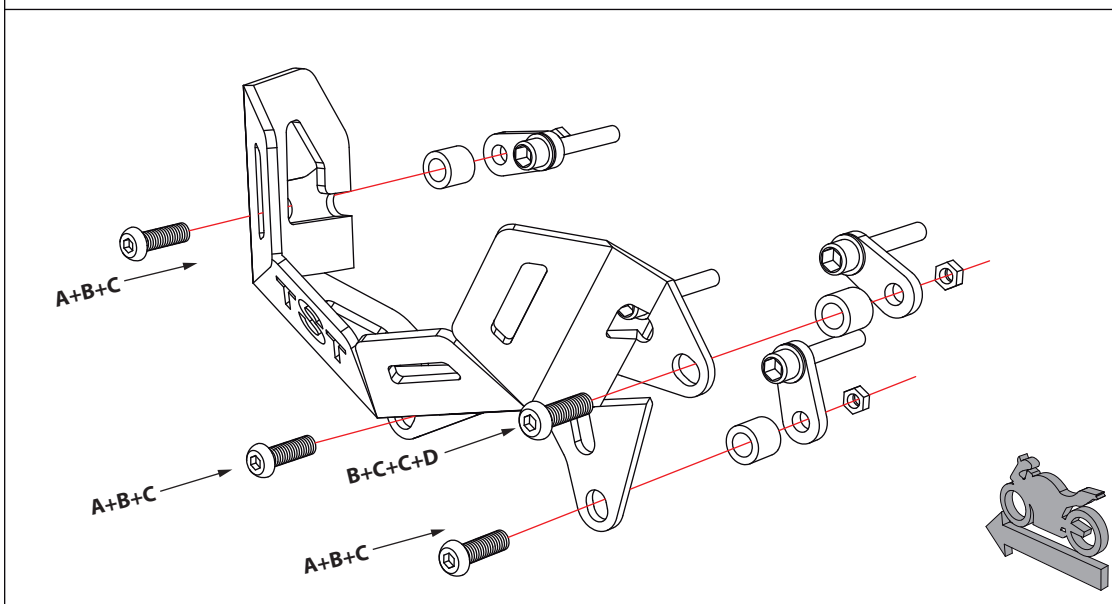
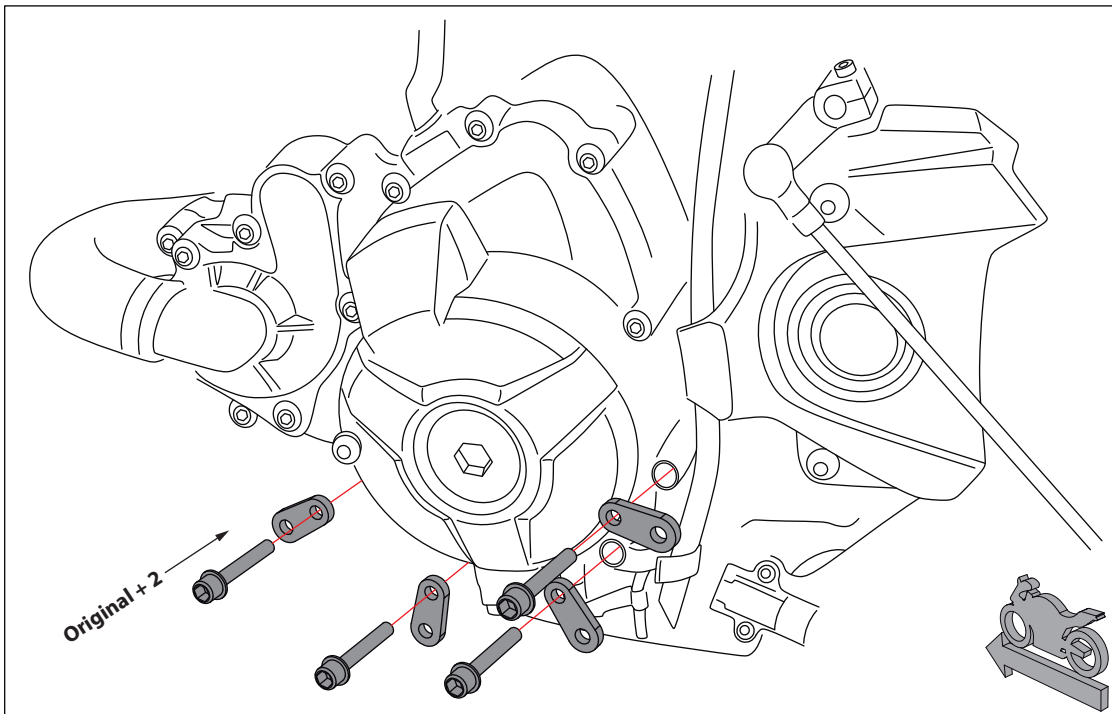

4-5mm

10mm

1



Cantidad - 1
Ubicación Centro

2

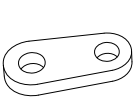

Cantidad - 4
Ubicación -

Ajuste de tornillos	
M4	- 4 Nm
M5	- 6 Nm
M6	- 9,6 Nm
M8	- 23 Nm
M10	- 46 Nm

A

Tornillo button

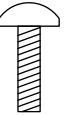

Cantidad - 3
Medidas 6 x 20 mm

B

Tuerca de seguridad

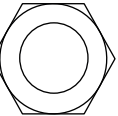

Cantidad - 4
Medidas 6 mm

C

Buje

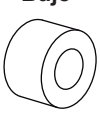

Cantidad - 5
Medidas 8x4.5x12

D

Tornillo button

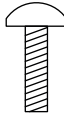

Cantidad - 1
Medidas 6 x 30 mm

