



Power Semiconductor Solutions

2015 Product Catalog

EXPERTISE ■ INNOVATION ■ RELIABILITY

IGBTs

**Hybrid &
SiC Modules**

MOSFET Modules

IPMs

DIIPM™

Discrete Thyristors

Discrete Rectifiers

**Thyristor & Diode
Modules**

**Fast Recovery &
Diode Modules**

Assemblies

IGBT Assemblies

Custom Modules

**Gate Drivers &
IPM Interface**

DC-DC Converters

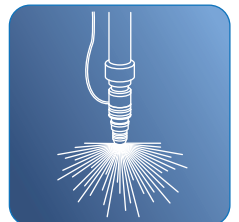
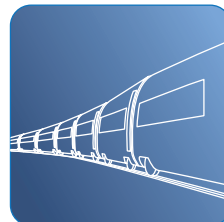
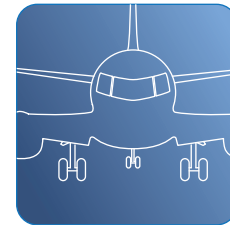
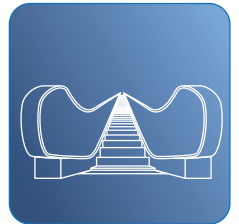
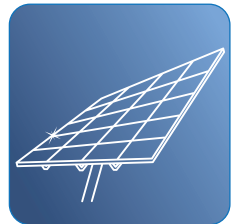

IGBTs

Applications Include:

- Hybrid Electric Vehicles (HEV/EV)
- Inverters
- Medical Power Supplies
- Motor Drives
- Servo Drives
- Traction Inverters
- UPS
- Welding

Circuit Configurations:

- Single
- Chopper
- Dual
- H-Bridge
- 6-Pac
- 7-Pac
- CIB

Development Kits available for some types. (Section M, Gate Drivers)

TABLE OF CONTENTS

Numbering System	A-2
250V IGBTs	A-2
600V Standard Frequency IGBTs, Up to 20kHz	
NF-Series Dual	A-3
NF-Series 6-Pac	A-4
NX-Series 7-Pac	A-5
Dual Extended Temperature Range IGBTs	A-6
Single & Low Side Chopper	A-7
600V High Frequency IGBTs, 30kHz to 70kHz	A-8
1200V Standard Frequency IGBTs, Up to 20kHz	
A-Series Single & Dual	A-9
S-Series Dual & AC Switch,	
MPD S-Series & NF-Series Dual	A-10
NF-Series 6-Pac & 7-Pac	A-11
NX-Series Dual	A-12
Single & Dual Extended Temperature Range IGBTs	A-13
NX-Series Chopper & 6-Pac	A-14
NX-Series 7-Pac	A-15
1200V High Frequency IGBTs, 30kHz to 70kHz	A-16
1700V IGBTs	
A-Series Single & Dual, S-Series Dual	A-17
MPD S-Series Dual & MPD NF-Series Chopper	A-18
NX-Series Dual & Chopper	A-19
NX-Series 7-Pac	A-20
1700V HVIGBTs	A-21
2500V HVIGBTs	A-22
3300V HVIGBTs	A-23
4500V HVIGBTs	A-24
6500V HVIGBTs	A-25
Outline Drawings	A-26



VOLTAGE: 250V TO 6500V
CURRENT: 35A TO 2500A

250 Volt IGBTs, (Refer to device datasheets at www.pwr.com for test conditions.)



CM200TU-5F



CM600HA-5F

MAXIMUM RATINGS (IGBT Inverter Sector)					ELECTRICAL CHARACTERISTICS										
Type	V _{CE(S)} Volts	I _C Amperes	I _{CM} Amperes	V _{RMS} Isolation Volts	Static				Dynamic						
					Test Conditions		Typ.	Max.	V _{GE} = 0V, V _{CE} = 10V			Inductive Load Switching Times			
					I _C Amperes	V _{GE} Volts	V _{CE(SAT)} Volts	V _{CE(SAT)} Volts	C _{ies} nF	C _{oes} nF	C _{res} nF	t _{d(on)} ns	t _r ns	t _{d(off)} ns	t _f ns
250V Single IGBT															
CM600HA-5F	250	600	1200	2500	600	10	1.2	1.7	165	7.5	5.6	1000	4000	1000	500
250V 6-Pac IGBT															
CM200TU-5F	250	200	400	2500	200	10	1.2	1.7	66	3.0	2.3	700	1800	700	500

FREE WHEEL DIODE				THERMAL CHARACTERISTICS			Weight Grams	Outline Drawings	
Type	I _{FM} Amperes	V _{FM} Volts	t _{rr} ns	Interface Per Module R _{th(j-c)} °C/W	IGBT (Max.) R _{th(j-c)} °C/W	Diode (Max.) R _{th(j-c)} °C/W		Number	Page
250V Single IGBT									
CM600HA-5F	600	2.0	300	0.04	0.13	0.19	400	2	A-26
250V 6-Pac IGBT									
CM200TU-5F	200	2.0	300	0.09	0.21	0.47	680	3	A-26

250V Single IGBT
CM600HA-5F

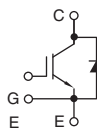

250V 6-Pac IGBT
CM200TU-5F

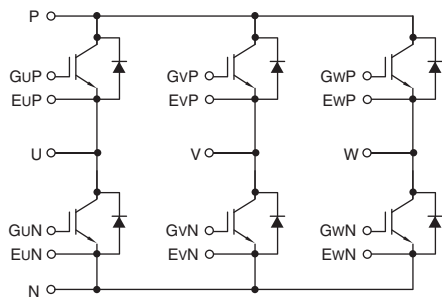

Numbering System

CM450DX-24S1 is a 450 Ampere, 1200 Volt, Dual IGBT



- (1) CM = IGBT Module
- (2) Current Rating: I_C (Amperes)
- (3) B = Four-in-One
D = Dual
E = Chopper
H = Single
M = CIB
R = Seven-in-One
T = Six
- (4) Outline or Minor Change
- (5) Voltage, V_{CE(S)} Volts (x50)
- (6) A = A-Series IGBT
F = 4th Generation Trench Gate
H = Total Performance H-Series Module
NF = 5th Generation CSTBT™ Trench Gate, Total Performance NF-Series Module
NFH = Total Performance NFH-Series Module, for High Frequency Use
R = High Voltage, Low Loss
S = 6th Generation CSTBT™ Trench Gate
S1 = Gen. 6.1 CSTBT Trench Gate

CSTBT is a registered trademark of Mitsubishi Electric Corp.

600V Standard Frequency Application IGBTs, Up to 20kHz

NF-Series Dual IGBTs, (Refer to device datasheets at www.pwr.com for test conditions.)



CM150DY-12NF, CM200DY-12NF,
CM300DY-12NF



CM400DY-12NF



CM600DY-12NF

MAXIMUM RATINGS (IGBT Inverter Sector)							ELECTRICAL CHARACTERISTICS								FREE-WHEEL DIODE			THERMAL CHARACTERISTICS				Weight Grams	Outline Drawings			
Type	V _{CE(S)} Volts	I _{C@T_C'} Amperes	I _{CM} Amperes	T _C ' °C	V _{RMS} Isolation Volts	Static				Dynamic				I _{FM} Amperes	V _{FM} Volts	t _{rr} ns	IGBT (Max.) R _{th(j-c)} °C/W	Diode (Max.) R _{th(j-c)} °C/W	IGBT Under Chip (Max.) R _{th(j-c)} °C/W	Contact Thermal Resistance R _{th(c-f)} °C/W	Number		Page			
						Test Conditions		Typ.	Max.	V _{GE} = 0V, V _{CE} = 10V			Inductive Load Switching Times													
						I _C Amperes	V _{GE} Volts	V _{CE(SAT)} Volts	V _{CE(SAT)} Volts	C _{ies} nF	C _{oes} nF	C _{res} nF	t _{d(on)} ns									t _r ns		t _{d(off)} ns	t _f ns	
NF-Series Dual IGBTs																										
CM150DY-12NF	600	150	300	97	2500	150	15	1.7	2.2	23	2.8	0.9	120	100	300	300	150	2.6	150	0.21	0.47	0.16	0.07	310	5	A-27
CM200DY-12NF	600	200	400	93	2500	200	15	1.7	2.2	30	3.7	1.2	120	120	300	300	200	2.6	150	0.19	0.35	0.13	0.07	310	5	A-27
CM300DY-12NF	600	300	600	89	2500	300	15	1.7	2.2	45	5.5	1.8	120	120	350	300	300	2.6	150	0.16	0.25	0.093	0.07	310	5	A-27
CM400DY-12NF	600	400	800	92	2500	400	15	1.7	2.2	60	7.3	2.4	300	200	450	300	400	2.6	250	0.11	0.19	0.066	0.04	400	6	A-27
CM600DY-12NF	600	600	1200	89	2500	600	15	1.7	2.2	90	11.0	3.6	500	300	750	300	600	2.6	250	0.11	0.18	0.046	0.02	580	7	A-28

NF-Series Dual IGBTs

CM150DY-12NF, CM200DY-12NF, CM300DY-12NF,
CM400DY-12NF, CM600DY-12NF

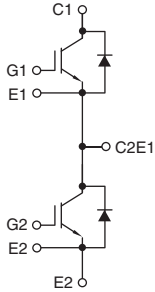

600V Standard Frequency Application IGBTs, Up to 20kHz

NF-Series 6-Pac IGBTs, (Refer to device datasheets at www.pwr.com for test conditions.)



CM75TL-12NF,
CM150TL-12NF

MAXIMUM RATINGS						ELECTRICAL CHARACTERISTICS										FREE-WHEEL DIODE			
Inverter Sector						Static				Dynamic									
Type	V _{CE(S)} Volts	I _C @T _C ' Amperes	I _{CM} Amperes	T _C ' °C	V _{RMS} Isolation Volts	Test Conditions		Typ.	Max.	V _{GE} = 0V, V _{CE} = 10V			Inductive Load Switching Times						
						I _C Amperes	V _{GE} Volts	V _{CE(SAT)} Volts	V _{CE(SAT)} Volts	C _{ies} nF	C _{oes} nF	C _{res} nF	t _{d(on)} ns	t _r ns	t _{d(off)} ns	t _f ns	I _{FM} Amperes	V _{FM} Volts	t _{rr} ns
6-Pac IGBTs																			
CM75TL-12NF	600	75	150	102	2500	75	15	1.7	2.2	11.3	1.4	0.45	120	100	300	300	75	2.8	100
CM150TL-12NF	600	150	300	93	2500	150	15	1.7	2.2	23.0	2.8	0.9	120	100	300	300	150	2.8	150

THERMAL CHARACTERISTICS				Weight Grams	Outline Drawings Number Page	
Type	Inverter Sector		Contact Thermal Resistance			
	IGBT Under Chip (Max.)	Diode Under Chip (Max.)	R _{th(j-c)} °C/W	R _{th(j-c)} °C/W	R _{th(c-f)} °C/W	
6-Pac IGBTs						
CM75TL-12NF	0.29	0.51	0.085	350	1	A-26
CM150TL-12NF	0.17	0.31	0.085	350	1	A-26

6-Pac IGBTs

CM75TL-12NF, CM150TL-12NF

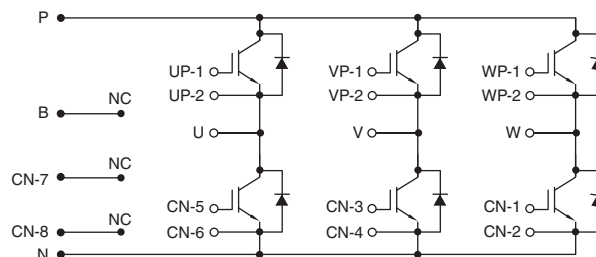

600V Standard Frequency Application IGBTs, Up to 20kHz

NX-Series 7-Pac IGBTs, (Refer to device datasheets at www.pwr.com for test conditions.)



CM100RX-12A, CM150RX-12A,
CM200RX-12A

MAXIMUM RATINGS						ELECTRICAL CHARACTERISTICS										FREE-WHEEL DIODE								
Inverter Sector						Brake Sector					Static				Dynamic						I _{FM} Amperes	V _{FM} Volts	t _{rr} ns	
Type	V _{CE(S)} Volts	I _{C@T_C' Amperes}	I _{CM} Amperes	T _C ' °C	V _{RMS} Isolation Volts	V _{CE(S)} Volts	I _{C@T_C' Amperes}	I _{CM@T_C' Amperes}	T _C ' °C	P _d Watts	Test Conditions		Typ.	Max.	V _{GE} = 0V, V _{CE} = 10V			Inductive Load Switching Times						
	I _C Amperes	V _{GE} Volts	V _{CE(SAT)} Volts	V _{CE(SAT)} Volts	C _{ies} nF	C _{oes} nF	C _{res} nF	t _{d(on)} ns	t _r ns	t _{d(off)} ns	t _f ns													
7-Pac IGBTs																								
CM100RX-12A	600	100	200	84	2500	600	50	100	103	280	100	15	1.7	2.1	11.3	1.4	0.45	100	100	300	400	100	2.8	200
CM150RX-12A	600	150	300	78	2500	600	75	150	84	280	150	15	1.6	2.0	15.0	2.0	0.6	120	100	350	550	150	2.8	200
CM200RX-12A	600	200	400	82	2500	600	100	200	88	400	200	15	1.6	2.0	20.0	2.7	0.8	120	150	350	550	200	2.8	200

THERMAL CHARACTERISTICS							Weight Grams	Outline Drawings	
Type	Inverter Sector		Brake Sector		Contact Thermal Resistance	Number		Page	
	IGBT Under Chip (Max.)	Diode Under Chip (Max.)	IGBT Under Chip (Max.)	Diode Under Chip (Max.)	R _{th(c-f)} °C/W				
7-Pac IGBTs									
CM100RX-12A	0.31	0.59	0.44	0.85	—	350	11	A-29	
CM150RX-12A	0.24	0.46	0.44	0.85	—	350	11	A-29	
CM200RX-12A	0.17	0.33	0.31	0.59	—	350	11	A-29	

7-Pac IGBTs

CM100RX-12A, CM150RX-12A, CM200RX-12A

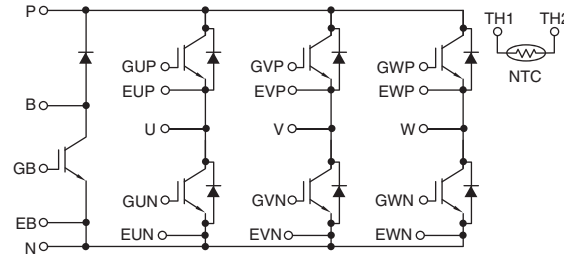

600V Standard Frequency Application IGBTs, Up to 20kHz

Dual Extended Temperature Range IGBTs, (Refer to device datasheets at www.pwr.com for test conditions.)



QID0640020



QID0660023

MAXIMUM RATINGS						ELECTRICAL CHARACTERISTICS														FREE-WHEEL DIODE			THERMAL CHARACTERISTICS		Weight Grams	Outline Drawings																
Type	V _{CES} Volts	I _C Amperes	I _{CM} Amperes	T _{j(MAX)} °C	V _{RMS} Isolation Volts	Static Test Conditions				Dynamic				Resistive Load Switching Times				I _{FM} Amperes	V _{FM} Volts	t _{rr} ns	IGBT (Max.) R _{th(j-c)} °C/W	Diode (Max.) R _{th(j-c)} °C/W	Number	Page																		
						I _C Amperes	V _{GE} Volts	V _{CE(SAT)} Volts	V _{CE(SAT)} Volts	V _{GE} = 0V, f = 1KHz				t _{d(on)} ns	t _r ns	t _{d(off)} ns	t _r ns																									
Dual Extended Temperature Range IGBTs																																										
QID0640020	600	400	800	150	2500	400	15	1.7	2.1	10	50	5.3	1.6	200	200	400	600	—	—	200	0.112	0.192	220	10	A-29																	
QID0660023	600	600	1200	150	2500	600	15	1.7	2.2	10	90	11.0	3.6	500	300	750	300	—	—	250	0.075	0.120	270	48	A-43																	

Dual Extended Temperature Range IGBTs

QID0640020

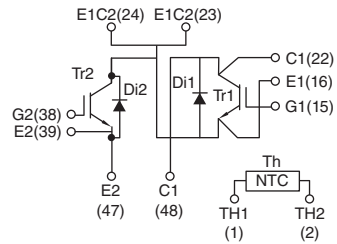

QID0660023

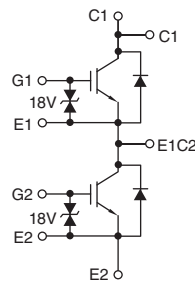

600V Standard Frequency Application IGBTs, Up to 20kHz

Single and Low Side Chopper IGBTs, (Refer to device datasheets at www.pwr.com for test conditions.)



QIS0660004



QIQ0645001

MAXIMUM RATINGS						ELECTRICAL CHARACTERISTICS											FREE-WHEEL DIODE			THERMAL CHARACTERISTICS		Weight Grams	Outline Drawings Number Page					
Type	V _{CES} Volts	I _C Amperes	I _{CM} Amperes	T _{j(MAX)} °C	V _{RMS} Isolation Volts	Static Test Conditions				Dynamic				Resistive Load Switching Times			I _{FM} Amperes	V _{FM} Volts	t _{rr} ns	IGBT (Max.) R _{th(j-c)} °C/W	Diode (Max.) R _{th(j-c)} °C/W							
						I _C Amperes	V _{GE} Volts	T _j = 25°C		V _{CE} Test Cond.	C _{ies} nF	C _{oes} nF	C _{res} nF									t _{d(on)} ns	t _r ns	t _{d(off)} ns	t _f ns			
								Typ.	Max.					V _{CE(SAT)} Volts	V _{CE(SAT)} Volts													
Single IGBT																												
QIS0660004	600	600	1200	150	2500	600	15	1.7	2.1	10	69	8.0	2.4	700	250	700	600	—	—	300	0.079	0.132	220	10	A-29			
Low Side Chopper IGBT																												
QIQ0645001	600	450	900	125	2000	450	15	2.1	2.8	10	45	15.9	9	350	600	350	300	450	2.2	110	0.075	0.075	400	49	A-43			

Single IGBT

QIS0660004

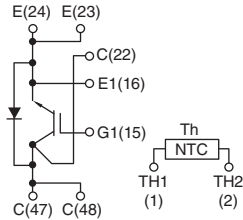

Low Side Chopper

QIQ0645001

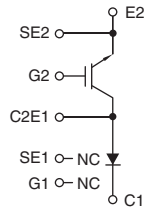

600V High Frequency Application IGBTs, 30kHz to 70kHz

NFH-Series Dual & Chopper IGBTs, (Refer to device datasheets at www.pwr.com for test conditions.)

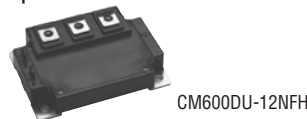
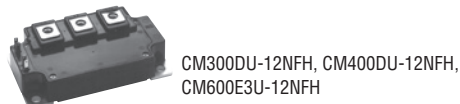
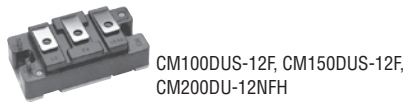

MAXIMUM RATINGS (IGBT Inverter Sector)					ELECTRICAL CHARACTERISTICS											FREE WHEEL DIODE			THERMAL CHARACTERISTICS			Weight Grams	Outline Drawings	
Type	V _{CE(S)} Volts	I _C Amperes	I _{CM} Amperes	V _{RMS} Isolation Volts	Static				Dynamic							I _{FM} Amperes	V _{FM} Volts	t _{rr} ns	IGBT (Max.) R _{th(j-c)} °C/W	Diode (Max.) R _{th(j-c)} °C/W	IGBT Under Chip (Max.) R _{th(j-c)} °C/W		Number	Page
					I _C Amperes	V _{GE} Volts	Typ. V _{CE(SAT)} Volts	Max. V _{CE(SAT)} Volts	V _{GE} = 0V, V _{CE} = 10V			Inductive Load Switching Times												
NFH-Series Dual IGBTs																								
CM100DUS-12F	600	100	200	2500	100	15	2.0	2.7	27	1.8	1.0	100	80	300	150	100	2.6	150	0.35	0.70	0.23	310	8	A-28
CM150DUS-12F	600	150	300	2500	150	15	2.0	2.7	41	2.7	1.5	120	100	350	150	150	2.6	150	0.24	0.47	0.19	310	8	A-28
CM200DU-12NFH	600	200	400	2500	200	15	2.0	2.7	55	3.6	2.0	120	100	350	150	200	2.6	150	0.21	0.35	0.15	310	18	A-32
CM300DU-12NFH	600	300	600	2500	300	15	2.0	2.7	83	5.4	3.0	250	120	500	150	300	2.6	200	0.16	0.24	0.10	400	19	A-32
CM400DU-12NFH	600	400	800	2500	400	15	2.0	2.7	110	7.2	4.0	400	120	700	150	400	2.6	200	0.13	0.18	0.076	400	19	A-32
CM600DU-12NFH	600	600	1200	2500	600	15	2.0	2.7	166	11.0	6.0	700	300	1400	150	600	2.6	200	0.11	0.12	0.053	400	24	A-34
NFH-Series Chopper IGBT																								
CM600E3U-12NFH	600	600	1200	2500	600	15	2.0	2.7	165	10.8	6.0	—	—	—	150	600	2.6	—	0.088	—	0.051	400	19	A-32

NFH-Series Dual IGBTs

CM100DUS-12F, CM150DUS-12F

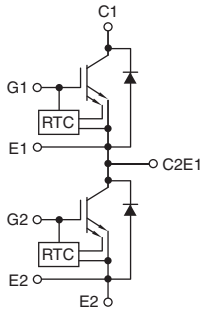

CM200DU-12NFH, CM300DU-12NFH, CM400DU-12NFH, CM600DU-12NFH

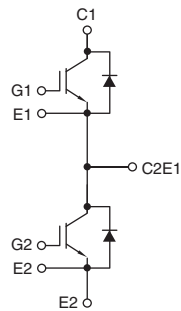

NFH-Series Chopper IGBT

CM600E3U-12NFH

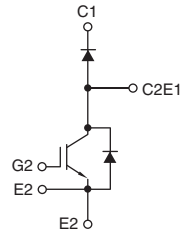

1200V Standard Frequency Application IGBTs, Up to 20kHz

A-Series Single & Dual IGBTs, (Refer to device datasheets at www.pwr.com for test conditions.)



CM400HA-24A,
CM600HA-24A



CM100DY-24A



CM600DY-24A

MAXIMUM RATINGS (IGBT Inverter Sector)						ELECTRICAL CHARACTERISTICS								FREE-WHEEL DIODE			THERMAL CHARACTERISTICS			Weight Grams	Outline Drawings Number Page				
Type	V _{CES} Volts	I _{C@T_C'} Amperes	I _{CM} Amperes	T _C ' °C	V _{RMS} Isolation Volts	Static				Dynamic				I _{FM} Amperes	V _{FM} Volts	t _{rr} ns	IGBT Under Chip (Max.) R _{th(j-c)} °C/W	Diode Under Chip (Max.) R _{th(j-c)} °C/W	Contact Thermal Resistance R _{th(c-f)} °C/W						
						Test Conditions		Typ.	Max.	V _{GE} = 0V, V _{CE} = 10V			Inductive Load Switching Times												
						I _C Amperes	V _{GE} Volts	V _{CE(SAT)} Volts	V _{CE(SAT)} Volts	C _{ies} nF	C _{oes} nF	C _{res} nF	t _{d(on)} ns							t _r ns	t _{d(off)} ns	t _f ns			
A-Series Single IGBTs																									
CM400HA-24A	1200	400	800	87	2500	400	15	2.1	3.0	70.0	6.0	1.4	550	180	600	350	400	3.8	250	0.053	0.080	0.02	480	29	A-36
CM600HA-24A	1200	600	1200	80	2500	600	15	2.1	3.0	105.0	9.0	2.0	660	190	700	350	600	3.8	250	0.034	0.053	0.02	480	29	A-36
A-Series Dual IGBTs																									
CM100DY-24A	1200	100	200	84	2500	100	15	2.1	3.0	17.5	1.5	0.34	100	70	400	350	100	3.8	150	0.186	0.34	0.022	310	20	A-33
CM600DY-24A	1200	600	1200	80	2500	600	15	2.1	3.0	94.0	8.0	1.8	660	190	700	350	600	3.8	250	0.034	0.062	0.018	580	22	A-33

A-Series Single IGBTs

CM400HA-24A, CM600HA-24A

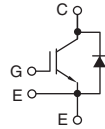

A-Series Dual IGBTs

CM100DY-24A, CM600DY-24A

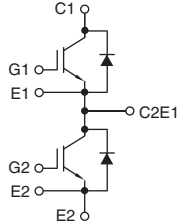

1200V Standard Frequency Application IGBTs, Up to 20kHz

S-Series Dual & AC Switch, MPD S-Series & NF-Series Dual IGBTs, (Refer to device datasheets at www.pwr.com for test conditions.)



MAXIMUM RATINGS (IGBT Inverter Sector)						ELECTRICAL CHARACTERISTICS								FREE-WHEEL DIODE			THERMAL CHARACTERISTICS				Weight Grams	Outline Drawings				
Type	V _{CE(S)} Volts	I _{C@T_C'} Amperes	I _{CM} Amperes	T _C ' °C	V _{RMS} Isolation Volts	Static				Dynamic				I _{FM} Amperes	V _{FM} Volts	t _{rr} ns	IGBT (Max.) R _{th(j-c)} °C/W	Diode (Max.) R _{th(j-c)} °C/W	IGBT Under Chip (Max.) R _{th(j-c)} °C/W	Contact Thermal Resistance R _{th(c-f)} °C/W		Number	Page			
						Test Conditions I _C Amperes	V _{GE} Volts	Typ. V _{CE(SAT)} Volts	Max. V _{CE(SAT)} Volts	V _{GE} = 0V, V _{CE} = 10V			Inductive Load Switching Times													
S-Series Dual IGBTs																										
CM300DY-24S	1200	300	600	120	2500	300	15	1.7	2.15	30	6	0.5	800	200	600	300	300	2.25	300	0.066	0.12	—	0.02	400	6	A-27
CM450DY-24S	1200	450	900	125	2500	450	15	1.7	2.15	45	9	0.75	800	200	600	300	450	2.15	300	0.045	0.068	—	0.018	580	16	A-31
CM600DY-24S	1200	600	1200	116	2500	600	15	1.7	2.15	60	12	1.0	800	200	600	300	600	2.15	300	0.03	0.06	—	0.018	580	16	A-31
CM800DY-24S	1200	800	1600	117	2500	800	15	1.7	2.15	80	16	1.32	800	200	600	300	800	2.15	300	0.028	0.045	—	0.015	1200	25	A-34
S-Series Dual AC Switch																										
CM400C1Y-24S	1200	350	800	124	2500	400	15	1.85	2.3	40	8	0.66	800	200	600	300	400	1.7	300	0.056	0.95	—	0.018	580	4	A-27
MPD S-Series Dual IGBTs																										
CM900DUC-24S	1200	900	1800	125	2500	900	15	1.55	1.9	90	18.0	1.5	900	250	950	350	900	1.65	450	0.023	0.039	—	0.006	1450	23	A-34
CM1400DUC-24S	1200	1400	2800	124	2500	1400	15	1.55	1.9	150	30.0	2.5	900	250	950	350	1400	1.65	450	0.016	0.026	—	0.006	1450	23	A-34
CM2500DY-24S	1200	2500	5000	56	2500	2500	15	1.7	2.4	250	25.0	3.0	800	200	700	300	—	—	300	0.016	0.027	—	0.0038	2000	38	A-39
NF-Series Dual IGBT																										
CM100DY-24NF	1200	100	200	113	2500	100	15	1.8	2.5	23	2.0	0.45	120	80	450	350	100	3.2	150	0.19	0.35	0.13	0.07	310	5	A-27

S-Series Dual IGBTs
CM300DY-24S, CM450DY-24S, CM600DY-24S, CM800DY-24S

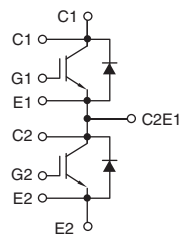

S-Series Dual AC Switch IGBT
CM400C1Y-24S

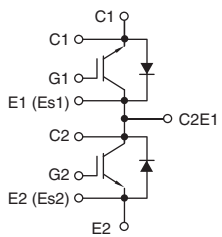

MPD S-Series Dual IGBTs
CM900DUC-24S

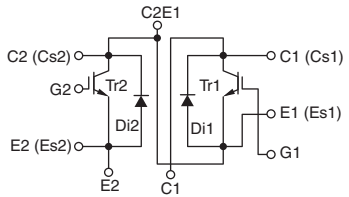

CM1400DUC-24S

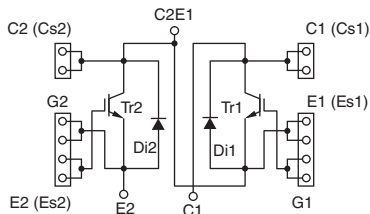

CM2500DY-24S

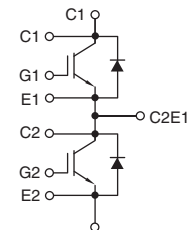

NF-Series Dual IGBT
CM100DY-24NF

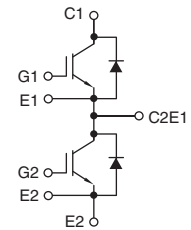

1200V Standard Frequency Application IGBTs, Up to 20kHz

NF-Series 6-Pac & 7-Pac IGBTs, (Refer to device datasheets at www.pwr.com for test conditions.)



CM50RL-24NF,
CM50TL-24NF

MAXIMUM RATINGS											ELECTRICAL CHARACTERISTICS							FREE-WHEEL DIODE						
Inverter Sector						Brake Sector					Static				Dynamic				I_{FM} Amperes	V_{FM} Volts	t_{rr} ns			
Type	V_{CES} Volts	$I_C@T_C'$ Amperes	I_{CM} Amperes	T_C' °C	V_{RMS} Isolation Volts	V_{CES} Volts	$I_C@T_C'$ Amperes	$I_{CM@T_C'}$ Amperes	T_C' °C	P_d Watts	Test Conditions		Typ. $V_{CE(SAT)}$ Volts	Max. $V_{CE(SAT)}$ Volts	$V_{GE} = 0V, V_{CE} = 10V$			Inductive Load Switching Times						
											I_C Amperes	V_{GE} Volts			C_{ies} nF	C_{obs} nF	C_{res} nF	$t_{d(on)}$ ns				t_r ns	$t_{d(off)}$ ns	t_f ns
6-Pac IGBT																								
CM50TL-24NF	1200	50	100	94	2500	—	—	—	—	—	50	15	2.1	3.0	8.5	0.75	0.17	100	50	300	350	50	3.8	100
7-Pac IGBT																								
CM50RL-24NF	1200	50	100	94	2500	1200	30	60	104	290	50	15	2.1	3.0	8.5	0.75	0.17	100	50	300	350	50	3.8	100

THERMAL CHARACTERISTICS						Weight Grams	Outline Drawings	
Type	Inverter Sector		Brake Sector		Contact Thermal Resistance		Number	Page
	IGBT Under Chip (Max.) $R_{th(j-c)}$ °C/W	Diode Under Chip (Max.) $R_{th(j-c)}$ °C/W	IGBT Under Chip (Max.) $R_{th(j-c)}$ °C/W	Diode Under Chip (Max.) $R_{th(j-c)}$ °C/W	$R_{th(c-f)}$ °C/W			
6-Pac IGBT								
CM50TL-24NF	0.32	0.43	—	—	0.085	350	1	A-26
7-Pac IGBT								
CM50RL-24NF	0.32	0.43	0.43	0.65	0.085	350	1	A-26

6-Pac IGBT

CM50TL-24NF

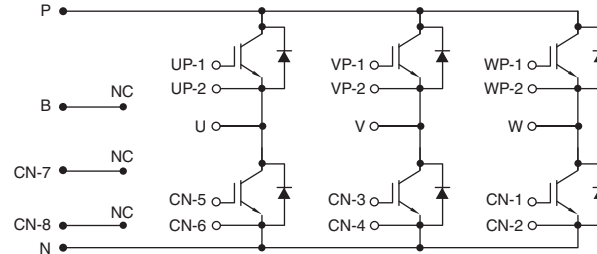

7-Pac IGBT

CM50RL-24NF

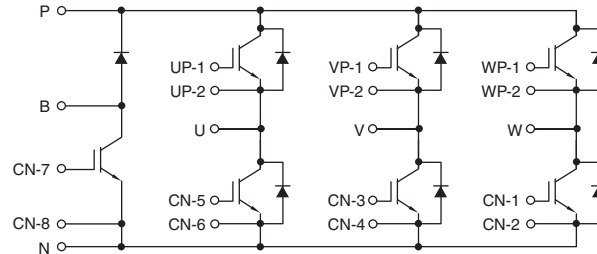

1200V Standard Frequency Application IGBTs, Up to 20kHz

NX-Series Dual IGBTs, (Refer to device datasheets at www.pwr.com for test conditions.)

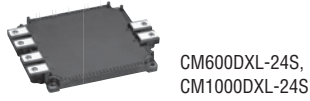
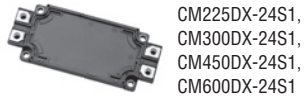

MAXIMUM RATINGS							ELECTRICAL CHARACTERISTICS										FREE-WHEEL DIODE		
Inverter Sector							Static				Dynamic								
Type	V _{CE(S)} Volts	I _{C@T_C' Amperes}	I _{CM} Amperes	T _C ' °C	P _d Watts	V _{RMS} Isolation Volts	Test Conditions		Typ. V _{CE(SAT)} Volts	Max. V _{CE(SAT)} Volts	Switching Energy		Inductive Load Switching Times				I _{FM} Amperes	V _{FM} Volts	E _{rr} mJ
							I _C Amperes	V _{GE} Volts			E _(on) mJ	E _(off) mJ	t _{d(on)} ns	t _r ns	t _{d(off)} ns	t _f ns			
NX-Series Dual IGBTs																			
CM150DX-24S	1200	150	300	120	1150	2500	150	15	1.7	2.15	24.2	16.0	800	200	600	300	150	2.15	12.2
CM225DX-24S1	1200	225	450	96	1250	4000	225	15	1.8	2.25	21.7	23.1	800	200	600	300	225	2.1	17.0
CM300DX-24S1	1200	300	600	107	1850	4000	300	15	1.7	2.15	30.7	35.7	800	200	600	300	300	2.0	19.0
CM450DX-24S1	1200	450	900	107	2775	4000	450	15	1.7	2.15	35.8	52.4	800	200	600	300	450	2.0	28.0
CM600DX-24S1	1200	600	1200	94	3330	4000	600	15	1.85	2.35	91.5	63.1	800	200	600	300	600	2.7	36.0
CM600DXL-24S	1200	600	1200	119	4545	2500	600	15	1.7	2.15	20.3	60.1	800	200	600	300	600	2.15	69.2
CM1000DXL-24S	1200	900	2000	124	7500	2500	1000	15	1.7	2.15	45.6	97.1	800	200	600	300	1000	2.15	96.7

THERMAL CHARACTERISTICS						
Inverter Sector						
Type	IGBT Under Chip (Max.) R _{th(j-c)} °C/W	Diode Under Chip (Max.) R _{th(j-c)} °C/W	Contact Thermal Resistance R _{th(c-f)} °C/W	Weight Grams	Outline Drawings	
					Number	Page
NX-Series Dual IGBTs						
CM150DX-24S	0.13	0.23	0.015	350	10	A-29
CM225DX-24S1	0.12	0.18	0.015	350	50	A-44
CM300DX-24S1	0.081	0.13	0.015	350	50	A-44
CM450DX-24S1	0.054	0.086	0.015	350	50	A-44
CM600DX-24S1	0.045	0.072	0.015	350	50	A-44
CM600DXL-24S	0.033	0.063	0.007	690	39	A-39
CM1000DXL-24S	0.02	0.038	0.007	690	39	A-39

NX-Series Dual IGBTs

CM150DX-24S

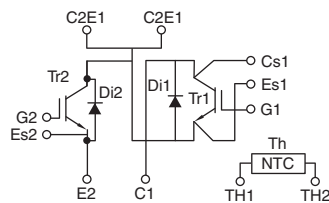

CM225DX-24S1, CM300DX-24S1, CM450DX-24S1, CM600DX-24S1

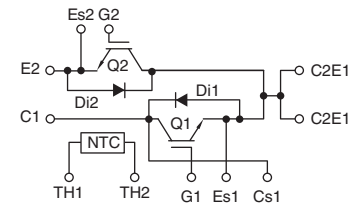

CM600DXL-24S, CM1000DXL-24S

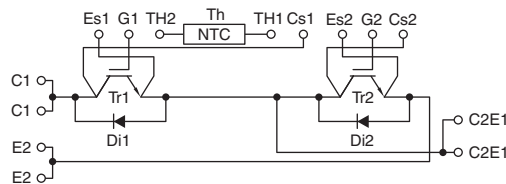

1200V Standard Frequency Application IGBTs, Up to 20kHz

Single & Dual Extended Temperature Range IGBTs, (Refer to device datasheets at www.pwr.com for test conditions.)



QIS1260015,
QID1230015

MAXIMUM RATINGS						ELECTRICAL CHARACTERISTICS										FREE-WHEEL DIODE			THERMAL CHARACTERISTICS		Weight Grams	Outline Drawings Number Page				
Type	V _{CES} Volts	I _C Amperes	I _{CM} Amperes	T _{J(MAX)} °C	V _{RMS} Isolation Volts	Static Test Conditions				Dynamic						I _{FM} Amperes	V _{FM} Volts	t _{rr} ns	IGBT (Max.) R _{th(j-c)} °C/W	Diode (Max.) R _{th(j-c)} °C/W						
						T _J = 25°C		V _{GE} = 0V, f = 1KHz				Resistive Load Switching Times														
						I _C Amperes	V _{GE} Volts	V _{CE(SAT)} Volts	V _{CE(SAT)} Volts	V _{CE} Test Cond.	C _{ies} nF	C _{oes} nF	C _{res} nF	t _{d(on)} ns	t _r ns	t _{d(off)} ns	t _r ns									
Single Extended Temperature Range IGBT																										
QIS1260015	1200	600	1200	150	2500	600	20	2.0	2.6	10	100	9.0	2.0	660	190	700	600	—	—	—	0.033	0.028	330	10	A-29	
Dual Extended Temperature Range IGBT																										
QID1230015	1200	300	600	150	2500	300	20	2.0	2.6	10	47	4.0	0.9	550	180	600	600	—	—	250	0.079	0.144	220	10	A-29	

Single Extended Temperature Range IGBT

QIS1260015

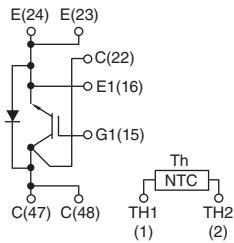

Dual Extended Temperature Range IGBT

QID1230015

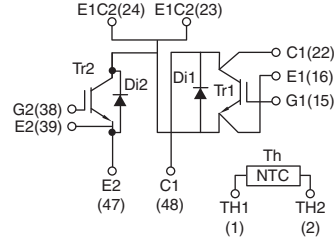

1200V Standard Frequency Application IGBTs, Up to 20kHz

NX-Series Chopper & 6-Pac IGBTs, (Refer to device datasheets at www.pwr.com for test conditions.)



CM150EXS-24S,
CM200EXS-24S,
CM300EXS-24S



CM75TX-24S

MAXIMUM RATINGS							ELECTRICAL CHARACTERISTICS										FREE-WHEEL DIODE		
Inverter Sector							Static				Dynamic								
Type	V _{CE(S)} Volts	I _C @T _C ' Amperes	I _{CM} Amperes	T _C ' °C	P _d Watts	V _{RMS} Isolation Volts	Test Conditions		Typ. V _{CE(SAT)} Volts	Max. V _{CE(SAT)} Volts	Switching Energy		Inductive Load Switching Times				I _{FM} Amperes	V _{FM} Volts	E _{rr} mJ
							I _C Amperes	V _{GE} Volts			E _(on) mJ	E _(off) mJ	t _{d(on)} ns	t _r ns	t _{d(off)} ns	t _f ns			
NX-Series Chopper IGBTs																			
CM150EXS-24S	1200	150	300	120	1150	2500	150	15	1.7	2.15	24.2	16.0	800	200	600	300	300	2.15	12.2
CM200EXS-24S	1200	200	400	119	1500	2500	200	15	1.7	2.15	30.7	21.5	800	200	600	300	400	2.25	14.2
CM300EXS-24S	1200	300	600	119	2270	2500	300	15	1.7	2.15	41.0	32.0	800	200	600	300	600	2.25	22.0
NX-Series 6-Pac IGBTs																			
CM75TX-24S	1200	75	150	122	600	2500	75	15	1.7	2.15	7.3	8.0	300	200	600	300	75	2.15	6.9
CM100TX-24S1	1200	100	200	107	625	4000	100	15	1.7	2.15	5.9	9.7	800	200	600	300	100	2.0	9.7
CM150TX-24S1	1200	150	300	107	935	4000	150	15	1.7	2.15	16.6	17.6	800	200	600	300	150	2.0	11.0

THERMAL CHARACTERISTICS					Weight Grams	Outline Drawings	
Inverter Sector			Contact Thermal Resistance	Number		Page	
Type	IGBT Under Chip (Max.) R _{th(j-c)} °C/W	Diode Under Chip (Max.) R _{th(j-c)} °C/W	R _{th(c-t)} °C/W				
NX-Series Chopper IGBTs							
CM150EXS-24S	0.13	0.23	0.025	210	43	A-41	
CM200EXS-24S	0.10	0.19	0.025	210	43	A-41	
CM300EXS-24S	0.066	0.12	0.025	210	43	A-41	
NX-Series 6-Pac IGBTs							
CM75TX-24S	0.25	0.4	0.015	300	13	A-30	
CM100TX-24S1	0.24	0.37	0.015	330	52	A-45	
CM150TX-24S1	0.16	0.26	0.015	330	52	A-45	

NX-Series Chopper IGBTs
CM150EXS-24S, CM200EXS-24S,
CM300EXS-24S

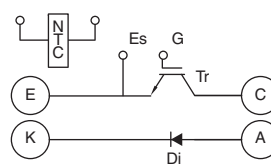

NX-Series 6-Pac IGBTs
CM75TX-24S, CM100TX-24S1, CM150TX-24S1

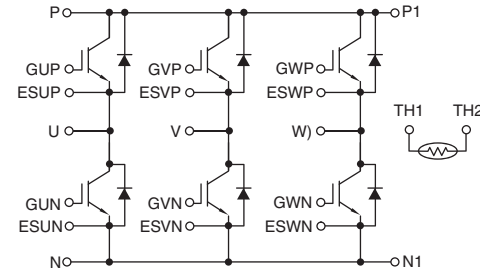

1200V Standard Frequency Application IGBTs, Up to 20kHz

NX-Series 7-Pac IGBTs, (Refer to device datasheets at www.pwr.com for test conditions.)

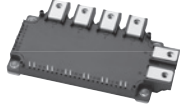

CM75RX-24S,
CM100RX-24S1,
CM150RX-24S1

MAXIMUM RATINGS							ELECTRICAL CHARACTERISTICS										FREE-WHEEL DIODE								
Inverter Sector							Brake Sector					Static				Dynamic						I _{FM} Amperes	V _{FM} Volts	E _{rr} mJ	
Type	V _{CES} Volts	I _{C@T_C'} Amperes	I _{CM} Amperes	T _C ' °C	P _d Watts	V _{RMS} Isolation Volts	V _{CES} Volts	I _{C@T_C'} Amperes	I _{CM@T_C'} Amperes	T _C ' °C	P _d Watts	Test Conditions		Typ.	Max.	Switching Energy		Inductive Load Switching Times							
	I _C Amperes	V _{GE} Volts	V _{CE(SAT)} Volts	V _{CE(SAT)} Volts	E _(on) mJ	E _(off) mJ	t _{d(on)} ns	t _r ns	t _{d(off)} ns	t _f ns															
NX-Series 7-Pac IGBTs																									
CM75RX-24S	1200	75	150	121	600	2500	1200	50	100	125	425	75	15	1.7	2.15	7.3	8.0	300	200	600	300	75	1.7	6.9	
CM100RX-24S1	1200	100	200	107	625	4000	1200	50	100	113	340	100	15	1.7	2.15	5.9	9.7	300	200	600	300	100	2.0	9.7	
CM150RX-24S1	1200	150	300	107	935	4000	1200	75	150	109	480	150	15	1.7	2.15	16.6	17.6	800	200	600	300	150	2.0	11.0	

THERMAL CHARACTERISTICS							Weight Grams	Outline Drawings	
Type	Inverter Sector		Brake Sector		Contact Thermal Resistance	Number		Page	
	IGBT Under Chip (Max.)	Diode Under Chip (Max.)	IGBT Under Chip (Max.)	Diode Under Chip (Max.)	R _{th(c-f)} °C/W				
	R _{th(j-c)} °C/W	R _{th(j-c)} °C/W	R _{th(j-c)} °C/W	R _{th(j-c)} °C/W					
NX-Series 7-Pac IGBTs									
CM75RX-24S	0.25	0.40	0.35	0.63	0.015	370	11	A-29	
CM100RX-24S1	0.24	0.37	0.44	0.66	0.015	370	53	A-45	
CM150RX-24S1	0.16	0.26	0.31	0.47	0.015	370	53	A-45	

NX-Series 7-Pac IGBTs

CM75RX-24S, CM100RX-24S1, CM150RX-24S1

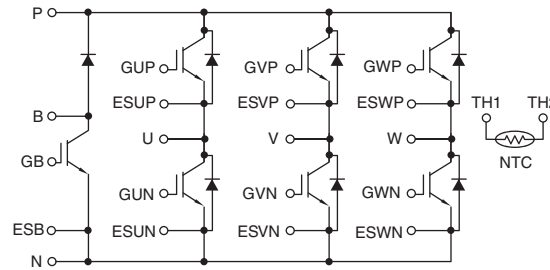

1200V High Frequency Application IGBTs, 30kHz to 70kHz

NFH-Series & NFJ-Series Dual & NFH-Series Chopper IGBTs, (Refer to device datasheets at www.pwr.com for test conditions.)



CM100DU-24NFH,
CM150DU-24NFH



CM200DU-24NFH,
CM300DU-24NFH



CM300DY-24NFH,
CM300E3Y6-24NFH,
CM400E3Y6-24NFH



CM300DX1-24NFJ



CM400DU-24NFH,
CM400DU-24NFJ,
CM600DU-24NFH

MAXIMUM RATINGS (IGBT Inverter Sector)					ELECTRICAL CHARACTERISTICS										FREE WHEEL DIODE			THERMAL CHARACTERISTICS			Weight Grams	Outline Drawings		
Type	V _{CE(S)} Volts	I _C Amperes	I _{CM} Amperes	V _{RMS} Isolation Volts	Static				Dynamic				I _{FM} Amperes	V _{FM} Volts	t _{rr} ns	IGBT (Max.) R _{th(j-c)} °C/W	Diode (Max.) R _{th(j-c)} °C/W	Contact Thermal Resistance R _{th(j-c)} °C/W	Number	Page				
					I _C Amperes	V _{GE} Volts	V _{CE(SAT)} Volts	V _{CE(SAT)} Volts	V _{GE} = 0V, V _{CE} = 10V			Inductive Load Switching Times												
					I _C Amperes	V _{GE} Volts	V _{CE(SAT)} Volts	V _{CE(SAT)} Volts	C _{ies} nF	C _{oes} nF	C _{res} nF	t _{d(on)} ns	t _r ns	t _{d(off)} ns	t _f ns									
NFH-Series & NFJ-Series Dual IGBTs																								
CM100DU-24NFH	1200	100	200	2500	100	15	5.0	6.5	16	1.3	0.3	100	50	250	150	100	3.5	150	0.22	0.47	0.17	310	18	A-32
CM150DU-24NFH	1200	150	300	2500	150	15	5.0	6.5	24	2.0	0.45	150	80	400	150	150	3.5	150	0.19	0.35	0.13	310	18	A-32
CM200DU-24NFH	1200	200	400	2500	200	15	5.0	6.5	32	2.7	0.6	300	80	500	150	200	3.5	250	0.15	0.24	0.095	400	19	A-32
CM300DU-24NFH	1200	300	600	2500	300	15	5.0	6.5	47	4.0	0.9	300	80	500	150	300	3.5	250	0.11	0.18	0.066	400	19	A-32
CM300DY-24NFH	1200	300	600	2500	300	15	5.0	6.5	47	4.0	0.9	300	80	500	150	600	3.5	250	0.066	0.1	0.040	400	6	A-27
CM300DX1-24NFJ	1200	300	300	2500	300	15	5.0	6.5	47	5.6	1.1	300	80	500	150	300	3.0	150	0.66	0.93	0.15	330	10	A-29
CM400DU-24NFH	1200	400	800	2500	400	15	5.0	6.5	63	5.3	1.2	300	100	500	150	400	3.5	250	0.12	0.23	0.051	580	24	A-34
CM400DU-24NFJ	1200	400	800	2500	400	15	5.0	6.5	63	5.3	1.2	300	100	500	150	400	5.5	100	0.51	0.093	0.02	580	24	A-34
CM600DU-24NFH	1200	600	1200	2500	600	15	5.0	6.5	95	8.0	1.8	400	120	700	150	600	3.5	250	0.083	0.15	0.034	580	24	A-34
NFH-Series Chopper IGBTs																								
CM300E3Y6-24NFH	1200	300	600	2500	300	15	5.0	6.5	47	4.0	0.9	300	80	500	150	600	2.8	100	0.071	0.411	0.020	400	6	A-27
CM400E3Y6-24NFH	1200	400	800	2500	400	15	5.0	6.5	63	5.3	1.2	300	100	500	150	800	2.8	100	0.057	0.098	0.020	400	6	A-27

NFH-Series & NFJ-Series Dual IGBTs

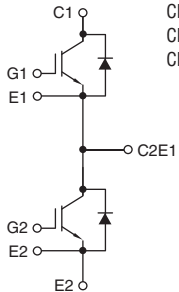

CM100DU-24NFH, CM150DU-24NFH, CM200DU-24NFH,
CM300DU-24NFH, CM300DY-24NFH, CM300DX1-24NFJ,
CM400DU-24NFH, CM400DU-24NFJ, CM600DU-24NFH

NFH-Series Chopper IGBTs

CM300E3Y6-24NFH, CM400E3Y6-24NFH

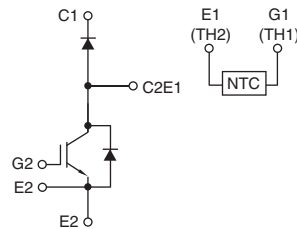

1700V IGBTs

A-Series Single & Dual, S-Series Dual IGBTs,

(Refer to device datasheets at www.pwr.com for test conditions.)



CM500HA-34A

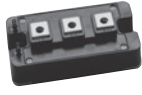

CM75DY-34A,
CM100DY-34A,
CM150DY-34A



CM200DY-34A



CM300DY-34A



CM400DY-34A

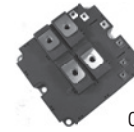

CM1200DC-34S

MAXIMUM RATINGS (IGBT Inverter Sector)						ELECTRICAL CHARACTERISTICS								FREE-WHEEL DIODE			THERMAL CHARACTERISTICS					Weight Grams	Outline Drawings																							
Type	V _{CES} Volts	I _C @T _C ' Amperes	I _{CM} Amperes	T _C ' °C	V _{RMS} Isolation Volts	Static				Dynamic				I _{FM} Amperes	V _{FM} Volts	t _{rr} ns	IGBT (Max.) R _{th(j-c)} °C/W	Diode (Max.) R _{th(j-c)} °C/W	IGBT Under Chip (Max.) R _{th(j-c)} °C/W	Diode Under Chip (Max.) R _{th(j-c)} °C/W	Contact Thermal Resistance R _{th(c-f)} °C/W																									
						Test Conditions I _C Amperes	V _{GE} Volts	Typ. V _{CE(SAT)} Volts	Max. V _{CE(SAT)} Volts	V _{GE} = 0V, V _{CE} = 10V																																				
A-Series Single IGBT																																														
CM500HA-34A	1700	500	1000	87	3500	500	15	2.2	2.8	120.0	14.0	2.6	900	500	1200	250	500	3.2	650	—	—	0.025	0.042	0.015	480	29	A-36																			
A-Series Dual IGBTs																																														
CM75DY-34A	1700	75	150	111	3500	75	15	2.2	2.8	18.5	2.1	0.4	200	150	550	350	75	3.0	300	—	—	0.16	0.29	0.022	310	20	A-33																			
CM100DY-34A	1700	100	200	108	3500	100	15	2.2	2.8	24.7	2.8	0.53	200	150	550	350	100	3.0	300	—	—	0.13	0.21	0.022	310	20	A-33																			
CM150DY-34A	1700	150	300	112	3500	150	15	2.2	2.8	37.0	4.2	0.8	550	190	750	350	150	3.0	450	—	—	0.078	0.15	0.02	310	20	A-33																			
CM200DY-34A	1700	200	400	109	3500	200	15	2.2	2.8	49.4	5.6	1.06	550	190	750	350	200	3.0	450	—	—	0.063	0.11	0.02	400	21	A-33																			
CM300DY-34A	1700	300	600	108	3500	300	15	2.2	2.8	74.0	8.4	1.6	600	200	850	350	300	3.0	450	—	—	0.043	0.072	0.02	580	22	A-33																			
CM400DY-34A	1700	400	800	107	3500	400	15	2.2	2.8	98.8	11.2	2.12	600	230	1000	350	400	3.0	500	—	—	0.033	0.055	0.014	1200	9	A-28																			
S-Series Dual IGBT																																														
CM1200DC-34S	1700	1200	2400	110	4000	1200	15	1.95	2.7	216.0	8.0	1.6	0.6	0.16	1.2	0.1	1200	2.3	0.2	0.0185	0.042	—	—	0.016	800	28	A-35																			

A-Series Single IGBT

CM500HA-34A

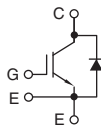

A-Series Dual IGBTs

CM75DY-34A, CM100DY-34A, CM150DY-34A,
CM200DY-34A, CM300DY-34A, CM400DY-34A

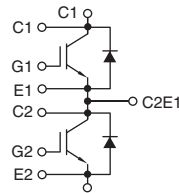

S-Series Dual IGBT

CM1200DC-34S

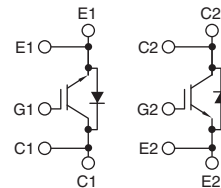

1700V IGBTs

MPD S-Series Dual & MPD NF-Series Chopper IGBTs,

(Refer to device datasheets at www.pwr.com for test conditions.)



CM1000DUC-34SA,
CM1000E3U-34NF

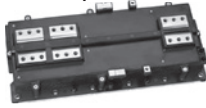

CM1800DY-34S

MAXIMUM RATINGS (IGBT Inverter Sector)						ELECTRICAL CHARACTERISTICS								FREE-WHEEL DIODE			THERMAL CHARACTERISTICS					Weight Grams	Outline Drawings				
Type	V _{CES} Volts	I _C @T _C ' Amperes	I _{CM} Amperes	T _C ' °C	V _{RMS} Isolation Volts	Static				Dynamic				I _{FM} Amperes	V _{FM} Volts	t _{rr} ns	IGBT (Max.) R _{th(j-c)} °C/W	Diode (Max.) R _{th(j-c)} °C/W	IGBT Under Chip (Max.) R _{th(j-c)} °C/W	Diode Under Chip (Max.) R _{th(j-c)} °C/W	Contact Thermal Resistance R _{th(c-f)} °C/W		Number	Page			
						I _C Amperes	V _{GE} Volts	V _{CE(SAT)} Volts	V _{CE(SAT)} Volts	V _{GE} = 0V, V _{CE} = 10V	Inductive Load Switching Times																
CM1000DUC-34SA	1700	1000	2000	125	4000	1000	15	1.9	2.4	260.0	27.0	5.0	900	350	1250	400	1000	4.0	400	0.015	0.024	—	—	0.060	1450	23	A-34
CM1800DY-34S	1700	1800	3600	66	3500	1800	15	2.1	2.6	460.0	48.0	8.0	1100	200	950	500	1800	2.0	350	0.016	0.027	—	—	0.038	2000	38	A-39

MPD S-Series Dual IGBT

MAXIMUM RATINGS (IGBT Inverter Sector)					ELECTRICAL CHARACTERISTICS								FREE-WHEEL DIODE			THERMAL CHARACTERISTICS			Weight Grams	Outline Drawings				
Type	V _{CES} Volts	I _C Amperes	I _{CM} Amperes	V _{RMS} Isolation Volts	Static				Dynamic				I _{FM} Amperes	V _{FM} Volts	t _{rr} µs	Interface Per Module R _{th(j-c)} °C/W	IGBT (Max.) R _{th(j-c)} °C/W	Diode (Max.) R _{th(j-c)} °C/W		Number	Page			
					I _C Amperes	V _{GE} Volts	V _{CE(SAT)} Volts	V _{CE(SAT)} Volts	V _{GE} = 0V, V _{CE} = 10V	Inductive Load Switching Times														
CM1000E3U-34NF	1700	1000	2000	3500	1000	15	2.45	2.80	220	25.0	4.7	0.6	0.15	0.9	0.2	2000	3.0	0.45	0.012	0.014	0.023	1400	23	A-34

MPD NF-Series Chopper IGBT

MPD S-Series Dual IGBT

CM1000DUC-34SA,
CM1800DY-34S

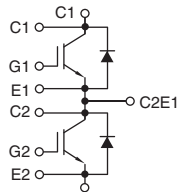

MPD NF-Series Chopper IGBT

CM1000E3U-34NF

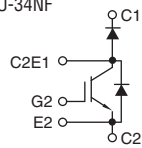

1700V IGBTs

NX-Series Dual & Chopper IGBTs,

(Refer to device datasheets at www.pwr.x.com for test conditions.)



CM150DX-34SA, CM200DX-34SA,
CM300DX-34SA, CM450DX-34SA



CM450DXL-34S,
CM600DXL-34S



CM200EXS-34SA

MAXIMUM RATINGS						ELECTRICAL CHARACTERISTICS										FREE-WHEEL DIODE				
Inverter Sector						Static				Dynamic										
						Test Conditions		Typ.	Max.	V _{GE} = 0V, V _{CE} = 10V			Inductive Load Switching Times							
Type	V _{CE} Volts	I _C @T _C ' Amperes	I _{CM} Amperes	T _C ' °C	V _{RMS} Isolation Volts	I _C Amperes	V _{GE} Volts	V _{CE(SAT)} Volts	V _{CE(SAT)} Volts	C _{ies} nF	C _{oes} nF	C _{res} nF	t _{d(on)} ns	t _r ns	t _{d(off)} ns	t _f ns	I _{FM} Amperes	V _{FM} Volts	t _{rr} ns	
NX-Series Dual IGBTs																				
CM150DX-34SA	1700	150	300	125	4000	150	15	1.9	2.4	26	1.1	0.26	400	100	700	600	150	4.0	300	
CM200DX-34SA	1700	200	400	125	4000	200	15	1.9	2.4	35	1.5	0.35	400	100	700	600	200	4.0	300	
CM300DX-34SA	1700	300	600	125	4000	300	15	1.9	2.4	52	2.2	0.52	400	100	700	600	300	4.0	300	
CM450DX-34SA	1700	450	900	125	4000	450	15	2.25	2.9	79	8.0	1.36	300	120	350	120	450	3.8	100	
CM450DXL-34SA	1700	450	900	125	4000	450	15	1.9	2.4	119	9.8	2.2	900	150	900	400	450	2.6	300	
CM600DXL-34SA	1700	600	1200	125	4000	600	15	1.9	2.4	158	13.0	2.9	900	150	900	400	600	2.6	300	
NX-Series Chopper IGBT																				
CM200EXS-34SA	1700	200	400	125	4000	200	15	2.2	2.7	35	1.5	0.35	400	100	700	600	400	4.0	300	

THERMAL CHARACTERISTICS					
Inverter Sector					
Type	IGBT Under Chip (Max.) R _{th(j-c)} °C/W	Diode Under Chip (Max.) R _{th(j-c)} °C/W	Contact Thermal Resistance R _{th(c-f)} °C/W	Weight Grams	Outline Drawings Number Page
NX-Series Dual IGBTs					
CM150DX-34SA	0.1	0.16	0.015	350	44 A-42
CM200DX-34SA	0.075	0.12	0.015	350	44 A-42
CM300DX-34SA	0.05	0.08	0.015	350	44 A-42
CM450DX-34SA	0.05	0.08	0.015	330	44 A-42
CM450DXL-34SA	0.034	0.052	0.007	690	39 A-39
CM600DXL-34SA	0.026	0.039	0.007	690	39 A-39
NX-Series Chopper IGBT					
CM200EXS-34SA	0.075	0.12	0.025	210	43 A-41

NX-Series Dual IGBTs
CM150DX-34SA, CM200DX-34SA,
CM300DX-34SA, CM450DX-34SA

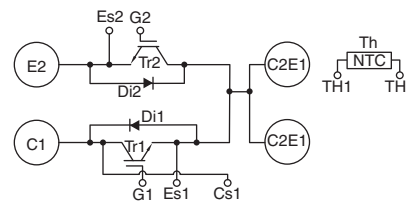

CM450DXL-34SA, CM600DXL-34SA

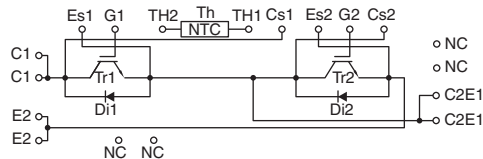

NX-Series Chopper IGBT
CM200EXS-34SA

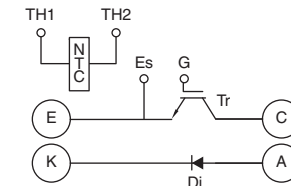

1700V IGBTs

NX-Series 7-Pac IGBTs, (Refer to device datasheets at www.pwr.com for test conditions.)



CM75RX-34SA

CM150RXL-34SA

MAXIMUM RATINGS										ELECTRICAL CHARACTERISTICS								FREE-WHEEL DIODE						
Inverter Sector					Brake Sector					Static				Dynamic										
Type	V_{CES} Volts	$I_C@T_C'$ Amperes	I_{CM} Amperes	T_C' °C	V_{RMS} Isolation Volts	V_{CES} Volts	$I_C@T_C'$ Amperes	$I_{CM@T_C'}$ Amperes	T_C' °C	P_d Watts	Test Conditions		Typ.	Max.	$V_{GE} = 0V, V_{CE} = 10V$						Inductive Load Switching Times			
											I_C Amperes	V_{GE} Volts	$V_{CE(SAT)}$ Volts	$V_{CE(SAT)}$ Volts	C_{ies} nF	C_{OES} nF	C_{res} nF	$t_{d(on)}$ ns	t_r ns	$t_{d(off)}$ ns	t_f ns	I_{FM} Amperes	V_{FM} Volts	t_{rr} ns
7-Pac IGBTs																								
CM75RX-34SA	1700	75	150	125	4000	1700	50	100	125	600	75	15	1.9	2.4	20.0	1.6	0.36	200	100	700	600	75	2.6	200
CM150RXL-34SA	1700	150	300	125	4000	1700	75	150	125	830	150	15	2.0	2.5	40.0	3.3	0.73	400	100	700	600	150	2.7	200

THERMAL CHARACTERISTICS						Weight Grams	Outline Drawings	
Type	Inverter Sector		Brake Sector		Contact Thermal Resistance		Number	Page
	IGBT Under Chip (Max.)	Diode Under Chip (Max.)	IGBT Under Chip (Max.)	Diode Under Chip (Max.)	$R_{th(c-f)}$ °C/W			
	$R_{th(j-c)}$ °C/W	$R_{th(j-c)}$ °C/W	$R_{th(j-c)}$ °C/W	$R_{th(j-c)}$ °C/W				
7-Pac IGBTs								
CM75RX-34SA	0.18	0.27	0.25	0.35	0.015	370	12	A-30
CM150RXL-34SA	0.1	0.16	0.18	0.27	0.007	690	42	A-41

7-Pac IGBTs
CM75RX-34SA, CM150RXL-34SA

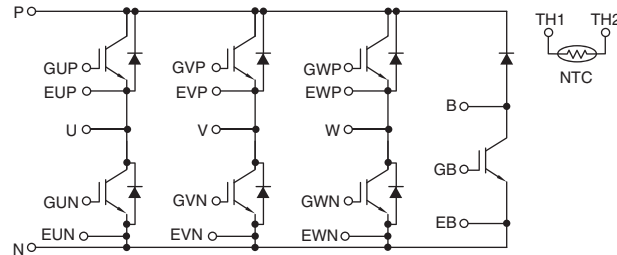

1700V HVIGBTs

Single, Dual, & Chopper HVIGBTs, (Refer to device datasheets at www.pwr.com for test conditions.)



CM1800HC-34N,
CM1200E4C-34N,
CM2400HC-34N



CM1800HCB-34N



CM1200DB-34N,
CM1200DC-34N

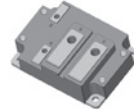

QIS1760002,
QIS1790001

MAXIMUM RATINGS (IGBT Inverter Sector)					ELECTRICAL CHARACTERISTICS											FREE-WHEEL DIODE			THERMAL CHARACTERISTICS			Weight Grams	Outline Drawings				
Type	V _{CES} Volts	I _C Amperes	I _{CM} Amperes	V _{RMS} Isolation Volts	Static				Dynamic							I _{FM} Amperes	V _{FM} Volts	t _{rr} µs	Interface Per Module				Weight Grams	Number	Page		
					Test Conditions		Typ.	Max.	V _{GE} = 0V, V _{CE} = 10V			Inductive Load Switching Times							R _{th(c-f)} °C/W	IGBT (Max.) R _{th(j-c)} °C/W	Diode (Max.) R _{th(j-c)} °C/W						
					I _C Amperes	V _{GE} Volts	V _{CE(SAT)} Volts	V _{CE(SAT)} Volts	C _{ies} nF	C _{oes} nF	C _{res} nF	t _{d(on)} µs	t _r µs	t _{d(off)} µs	t _f µs												
1700V Single HVIGBTs																											
CM800HA-34H	1700	800	1600	4000	800	15	2.75	3.58	93	13.3	5.1	1.2	1.5	2.0	0.6	800	3.12	2.0	0.012	0.015	0.048	1500	26	A-35			
CM1200HA-34H	1700	1200	2400	4000	1200	15	2.75	3.58	140	20.0	7.6	1.2	1.5	2.0	0.6	1200	3.12	2.0	0.008	0.010	0.032	1500	26	A-35			
CM1800HC-34N	1700	1800	3600	4000	1800	15	2.15	—	264	14.4	4.2	1.0	0.35	2.0	0.25	1800	2.4	1.0	0.011	0.013	0.028	800	27	A-35			
CM1800HCB-34N	1700	1800	3600	4000	1800	15	2.0	—	352	19.2	5.6	0.95	0.3	1.6	0.25	1800	2.35	1.2	0.007	0.009	0.013	1500	30	A-36			
CM2400HC-34N	1700	2400	4800	4000	2400	15	2.15	—	352	19.2	5.6	1.0	0.35	2.0	0.25	2400	2.4	1.0	0.008	0.0098	0.021	800	27	A-35			
CM2400HCB-34N	1700	2400	4800	4000	2400	15	2.1	—	396	21.6	6.3	0.95	0.3	1.6	0.25	2400	2.5	1.2	0.006	0.008	0.012	1500	30	A-36			
QIS1760002	1700	600	1200	3500	600	15	2.0	2.5	104	4.4	1.04	TBD	TBD	TBD	TBD	600	—	0.3	0.015	0.026	0.038	600	56	A-46			
QIS1790001	1700	900	1800	3500	900	15	2.0	2.5	156	6.6	1.56	0.4	0.1	0.7	0.6	900	—	0.3	0.015	0.018	0.028	600	56	A-46			
1700V Dual HVIGBTs																											
CM600DY-34H	1700	600	1200	4000	600	15	2.75	3.58	70	10.0	3.8	1.2	1.5	2.0	0.6	600	3.12	2.0	0.016	0.02	0.064	1500	31	A-36			
CM800DZ-34H	1700	800	1600	4000	800	15	2.80	3.64	72	9.0	3.6	1.6	2.0	2.7	0.8	800	3.38	2.7	0.020	0.025	0.043	1500	31	A-36			
CM1200DB-34N	1700	1200	2400	4000	1200	15	2.15	2.80	176	9.6	2.8	1.0	0.4	1.2	0.3	1200	2.3	1.0	0.016	0.018	0.04	1300	28	A-35			
CM1200DC-34N	1700	1200	2400	4000	1200	15	2.15	—	125	12.5	2.1	1.2	0.3	1.8	0.4	1200	2.3	2.0	0.008	0.0195	0.04	1000	28	A-35			
1700V Chopper HVIGBTs																											
CM600E2Y-34H	1700	600	1200	4000	600	15	2.75	3.58	70	10.0	3.8	1.2	1.5	2.0	0.6	600	3.25	2.0	0.016	0.02	0.064	1500	32	A-37			
CM1200E4C-34N	1700	1200	2400	4000	1200	15	2.15	2.80	176	9.6	2.8	0.8	0.4	1.2	0.3	1200	2.6	1.0	0.016	0.019	0.042	800	27	A-35			

1700V Single HVIGBTs

CM800HA-34H, CM1200HA-34H,
CM1800HC-34N, CM2400HC-34N

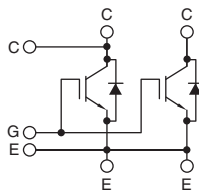

CM1800HCB-34N,
CM2400HCB-34N

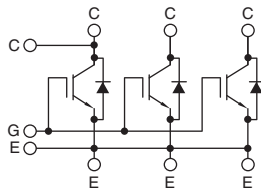

QIS1760002,
QIS1790001

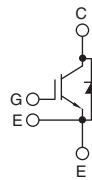

1700V Dual HVIGBTs

CM600DY-34H, CM800DZ-34H

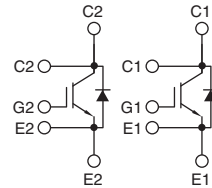

CM1200DB-34N, CM1200DC-34N

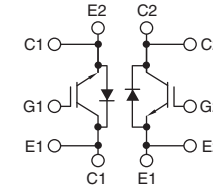

1700V Chopper HVIGBTs

CM600E2Y-34H

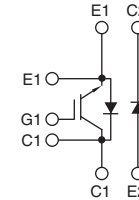

CM1200E4C-34N

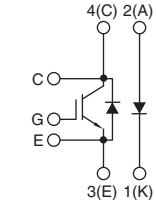

2500V IGBT, (Refer to device datasheets at www.pwr.com for test conditions.)



QIS2510001

MAXIMUM RATINGS						ELECTRICAL CHARACTERISTICS												FREE-WHEEL DIODE			THERMAL CHARACTERISTICS		Weight Grams	Outline Drawings Number Page					
Type	V _{CES} Volts	I _C Amperes	I _{CM} Amperes	T _{j(MAX)} °C	V _{RMS} Isolation Volts	Static Test Conditions				Dynamic								I _{FM} Amperes	V _{FM} Volts	t _{rr} ns	IGBT (Max.) R _{th(j-c)} °C/W	Diode (Max.) R _{th(j-c)} °C/W							
						T _j = 25°C		V _{GE} = 0V, f = 1KHz				Resistive Load Switching Times																	
						I _C Amperes	V _{GE} Volts	V _{CES(SAT)} Volts	V _{CES(SAT)} Volts	V _{CE(SAT)} Test Cond.	C _{ies} nF	C _{oes} nF	C _{res} nF	t _{d(on)} ns	t _r ns	t _{d(off)} ns	t _r ns												
2500V Single IGBT																													
QIS2510001	2500	100	200	150	TBD	100	15	3.2	4.2	10	10	1.1	0.33	TBD	TBD	TBD	TBD	—	—	—	0.10 Typ.	—	21	46	A-42				

2500V Single IGBT

QIS2510001

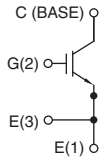

3300 Volt HVIGBTs, (Refer to device datasheets at www.pwr.com for test conditions.)



MAXIMUM RATINGS (IGBT Inverter Sector)					ELECTRICAL CHARACTERISTICS										FREE-WHEEL DIODE			THERMAL CHARACTERISTICS			Weight Grams	Outline Drawings		
Type	V _{CE(S)} Volts	I _C Amperes	I _{CM} Amperes	V _{RMS} Isolation Volts	Static				Dynamic						I _{FM} Amperes	V _{FM} Volts	t _{rr} μs	Interface Per Module R _{th(j-c)} °C/W	IGBT (Max.) R _{th(j-c)} °C/W	Diode (Max.) R _{th(j-c)} °C/W		Weight Grams	Number	Page
					I _C Amperes	V _{GE} Volts	V _{CE(SAT)} Volts	V _{CE(SAT)} Volts	V _{GE} = 0V, V _{CE} = 10V			Inductive Load Switching Times												
3300V Single HVIGBTs																								
CM400HG-66H	3300	400	800	10200	400	15	3.3	4.2	60	6.0	5.4	1.6	1.0	2.5	1.0	400	3.6	1.4	0.018	0.030	0.060	520	35	A-38
CM800HB-66H	3300	800	1600	6000	800	15	3.8	4.94	120	12.0	3.6	1.6	2.0	2.5	1.0	800	3.64	1.4	0.008	0.012	0.024	1500	33	A-37
CM800HC-66H	3300	800	1600	6000	800	15	3.3	4.2	120	12.0	3.6	1.6	1.0	2.5	1.0	800	2.8	1.4	0.008	0.013	0.025	1000	41	A-40
CM1000HC-66R	3300	1000	2000	6000	1000	15	2.45	—	140	8.7	4.0	1.0	0.28	2.7	0.3	2000	2.15	0.5	0.009	0.012	0.0225	900	41	A-40
CM1200HC-66H	3300	1200	2400	6000	1200	15	3.3	4.29	180	18.0	5.4	1.6	2.0	2.5	1.0	1200	3.64	1.4	0.008	0.010	0.020	2200	30	A-36
CM1200HG-66H	3300	1200	2400	10200	1200	15	3.3	4.2	180	18.0	5.4	1.6	1.0	2.5	1.0	1200	3.6	1.4	0.006	0.010	0.020	1350	36	A-38
CM1500HC-66R	3300	1500	3000	6000	1500	15	—	5.0	210	13.0	6.0	1.0	0.25	2.7	0.3	1500	2.15	0.55	0.008	—	0.015	1200	30	A-36
CM1500HG-66R	3300	1500	3000	10200	1500	—	2.15	—	210	13.0	6.0	1.0	0.28	2.7	0.3	1500	2.15	0.50	0.006	0.0085	0.0155	1400	14	A-31
3300V Dual HVIGBTs																								
QID3310005	3300	100	200	9000	100	15	2.7	3.3	12	0.8	0.35	0.8	0.16	3.2	1.3	200	—	0.5	0.018	0.150	0.22	900	37	A-38
QID3320002	3300	200	400	9000	200	15	2.7	3.3	23	1.5	0.7	0.8	0.16	3.2	1.3	200	—	0.85	0.018	0.074	0.11	900	37	A-38
QID3320004	3300	200	400	6000	200	15	2.7	3.0	23	1.5	0.7	0.8	0.16	3.2	1.3	400	—	0.85	0.018	0.060	0.096	800	51	A-44
QID3340001	3300	400	800	6000	400	15	2.7	3.3	46	3.0	1.3	1.0	0.28	2.7	0.3	800	—	0.7	0.010	0.036	0.0675	900	57	A-46
QID3350001	3300	500	1000	6000	500	15	2.7	2.85	58	3.6	1.6	1.1	0.31	3.0	0.33	1000	—	0.7	0.008	0.0275	0.052	900	57	A-46
3300V Split Dual HVIGBT																								
CM400DY-66H	3300	400	800	6000	400	15	4.4	5.72	40	4.0	1.2	1.0	2.0	2.0	1.0	400	4.29	1.2	0.016	0.036	0.072	1500	34	A-37
3300V Chopper HVIGBTs																								
CM800E2C-66H	3300	800	1600	6000	800	15	3.8	4.94	120	12.0	3.6	1.6	2.0	2.5	1.0	800	3.8	1.4	0.008	0.013	0.025	1500	30	A-36
CM800E6C-66H	3300	800	1600	6000	800	15	3.3	4.2	120	12.0	3.6	1.6	1.0	2.5	1.0	800	2.8	1.4	0.008	0.013	0.025	1500	30	A-36
CM1000E4C-66R	3300	1000	2000	6000	1000	15	2.45	—	140	8.7	4.0	1.0	0.28	2.7	0.3	2000	2.15	0.5	0.007	0.012	0.0225	1200	30	A-36

3300V Single HVIGBTs

CM400HG-66H
CM800HB-66H, CM800HC-66H, CM1000HC-66R

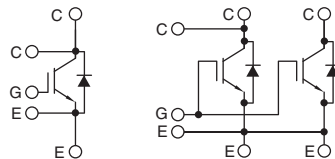

3300V Dual HVIGBTs

CM1200HC-66H, CM1200HG-66H, CM1500HC-66R, CM1500HG-66R

QID3310005, QID3320002

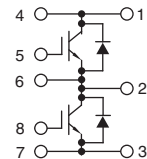

QID3320004

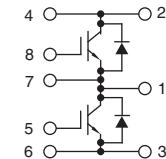

QID3340001, QID3350001

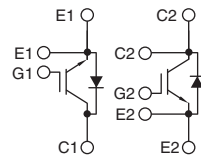

3300V Split Dual HVIGBT

CM400DY-66H

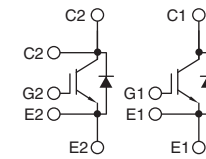

3300V Chopper HVIGBTs

CM800E2C-66H, CM800E6C-66H, CM1000E4C-66R

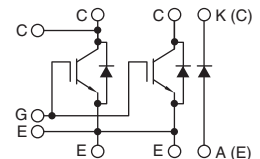

DC-DC Converters

Gate Drivers & IPM Interface

Custom Modules

IGBT Assemblies

Assemblies

Fast Recovery Diode Modules

Thyristor & Diode Modules

Discrete Rectifiers

Discrete Thyristors

DIPIM

IPMs

MOSFET Modules

Hybrid & SiC Modules

IGBTs

4500V HVIGBTs, (Refer to device datasheets at www.pwr.com for test conditions.)

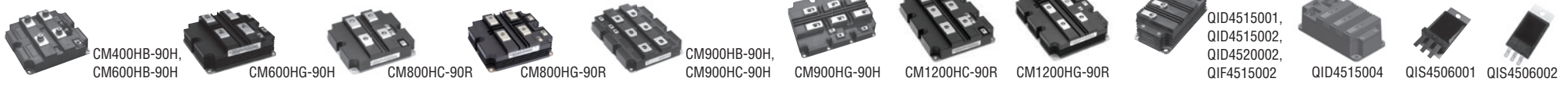

MAXIMUM RATINGS (IGBT Inverter Sector)					ELECTRICAL CHARACTERISTICS										FREE-WHEEL DIODE			THERMAL CHARACTERISTICS			Weight Grams	Outline Drawings		
Type	V _{CES} Volts	I _C Amperes	I _{CM} Amperes	V _{RMS} Isolation Volts	Static				Dynamic						I _{FM} Amperes	V _{FM} Volts	t _{rr} μs	Interface Per Module R _{th(c-f)} °C/W	IGBT (Max.) R _{th(f-c)} °C/W	Diode (Max.) R _{th(f-c)} °C/W		Number	Page	
					I _C Amperes	V _{GE} Volts	V _{CE(SAT)} Volts	Max. V _{CE(SAT)} Volts	V _{GE} = 0V, V _{CE} = 10V, f = 1mHz			Inductive Load Switching Times												
4500V Single HVIGBTs																								
QIS4506001	4500	60	120	TBD	60	6.0	3.0	3.9	9.0	0.65	0.2	2.40	2.40	6.0	1.2	—	—	—	—	0.10 Typ.	—	21	46	A-42
QIS4506002	4500	60	120	TBD	60	6.0	3.0	3.9	9.0	0.65	0.2	2.40	2.40	6.0	1.2	—	—	—	—	0.10 Typ.	—	21	47	A-43
CM400HB-90H	4500	400	800	6000	400	5.0	3.0	3.9	72	5.30	1.6	2.40	2.40	6.0	1.2	400	4.0	1.8	0.015	0.023	0.045	1500	33	A-37
CM600HB-90H	4500	600	1200	6000	600	15	3.0	3.9	108	8.00	2.4	2.40	2.40	6.0	1.2	600	4.0	1.8	0.010	0.015	0.030	1500	33	A-37
CM600HG-90H	4500	600	1200	10,200	600	15	3.45	—	108	8.00	2.4	2.40	1.20	6.0	1.2	600	4.8	1.8	0.009	0.016	0.033	1000	40	A-40
CM800HC-90R	4500	800	1600	6000	800	15	3.5	5.1	117	7.30	3.3	0.95	0.3	3.6	0.4	800	2.5	0.7	0.009	0.015	0.029	900	15	A-31
CM800HG-90R	4500	800	1600	10,200	800	15	3.5	—	117	7.30	3.3	1.00	0.28	3.6	0.35	1600	2.5	0.7	0.009	0.016	0.0295	900	45	A-42
CM900HG-90H	4500	900	1800	10,200	900	15	3.45	—	162	12.0	3.6	2.40	1.20	6.0	1.2	1800	4.8	—	0.006	0.011	0.022	1350	36	A-38
CM900HB-90H	4500	900	1800	6000	900	15	3.0	3.9	162	12.0	3.6	2.40	2.40	6.0	1.2	900	4.0	1.8	0.007	0.010	0.020	2200	30	A-36
CM900HC-90H	4500	900	1800	6000	900	15	3.0	3.9	162	12.0	3.6	2.40	2.40	6.0	1.2	900	4.0	1.8	—	—	—	2200	30	A-36
CM1200HC-90R	4500	1200	2400	6000	1200	15	3.5	—	175	11.0	5.0	1.00	0.30	6.25	0.4	2400	2.6	0.7	0.006	0.095	0.0185	1200	17	A-32
CM1200HG-90R	4500	1200	2400	10,200	1200	15	3.3	—	180	12.0	6.0	0.95	0.25	5.8	0.4	1200	2.6	0.9	0.006	0.010	0.019	1400	14	A-31
4500V Dual HVIGBTs																								
QID4515001	4500	150	300	9000	150	15	3.5	3.9	18	1.33	0.4	1.50	0.50	3.5	1.2	300	—	1.8	0.018	0.087	0.174	900	37	A-38
QID4515002	4500	150	300	9000	150	15	3.8	—	19	1.22	0.55	1.00	0.30	3.6	0.36	300	—	0.7	0.018	0.083	0.157	900	37	A-38
QID4515004	4500	150	300	6000	150	15	3.8	—	19	1.22	0.55	1.00	0.30	3.6	0.36	300	—	0.7	0.018	0.079	0.149	800	51	A-44
QID4520002	4500	200	400	9000	200	15	3.5	—	29	1.83	0.83	1.00	0.30	3.6	0.36	400	—	0.7	0.018	0.055	0.104	900	37	A-38
4500V Dual Common Collector HVIGBT																								
QIF4515002	4500	150	300	9000	150	15	3.8	—	19	1.22	0.55	1.00	0.30	3.6	0.36	150	—	0.7	0.018	0.083	0.157	900	37	A-38

4500V Single HVIGBTs

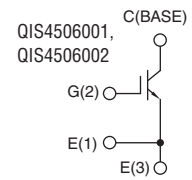
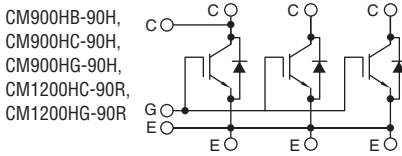
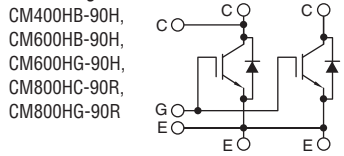

4500V Dual HVIGBTs

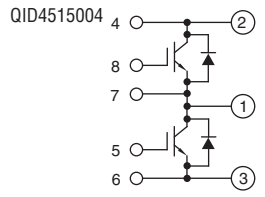
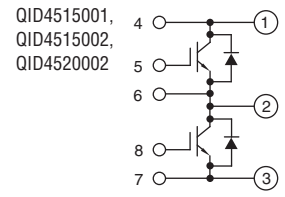

4500V Dual Common Collector HVIGBT

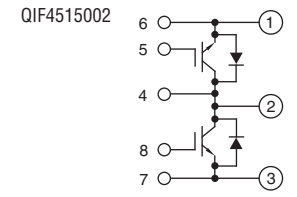

6500V HVIGBTs, (Refer to device datasheets at www.pwr.com for test conditions.)



CM400HG-130H



CM400E2G-130H,
CM400E4G-130H,
CM600HG-130H



CM750HG-130R



CM200HG-130H



QIS6502002



QIC6508001,
QID6508001

MAXIMUM RATINGS (IGBT Inverter Sector)					ELECTRICAL CHARACTERISTICS										FREE-WHEEL DIODE			THERMAL CHARACTERISTICS			Weight Grams	Outline Drawings Number Page		
Type	V _{CES} Volts	I _C Amperes	I _{CM} Amperes	V _{RMS} Isolation Volts	Static				Dynamic						I _{FM} Amperes	V _{FM} Volts	t _{rr} µs	Interface Per Module						
					Test Conditions		Typ.	Max.	V _{GE} = 0V, V _{CE} = 10V			Inductive Load Switching Times						R _{th(c-f)} °C/W	IGBT (Max.) R _{th(j-c)} °C/W	Diode (Max.) R _{th(j-c)} °C/W				
					I _C Amperes	V _{GE} Volts			V _{CE(SAT)} Volts	V _{CE(SAT)} Volts	C _{ies} nF	C _{oes} nF	C _{res} nF	t _{d(on)} µs							t _r µs	t _{d(off)} µs	t _f µs	
6500V Single HVIGBTs																								
QIS6502002	6500	25	50	—	25	15	4.2	—	6.28	0.38	0.06	0.64	0.27	1.54	0.62	—	—	—	0.10	0.140	—	20	47	A-43
CM200HG-130H	6500	200	400	10200	200	15	5.10	—	41	2.5	0.7	1.20	0.35	6.6	3.3	200	4.0	2.4	0.018	0.042	0.066	800	35	A-38
CM400HG-130H	6500	400	800	10200	400	15	4.50	—	82	5.0	1.4	1.20	0.35	8.2	0.5	400	4.0	1.0	0.009	0.021	0.033	1000	40	A-40
CM600HG-130H	6500	600	1200	10200	600	15	5.10	—	124	7.6	2.2	1.20	0.35	4.5	4.5	600	3.8	2.4	0.006	0.014	0.024	1500	36	A-38
CM750HG-130R	6500	750	1500	10200	750	15	3.30	—	140	6.0	2.4	1.15	0.20	8.3	0.5	750	2.8	0.8	0.006	0.012	0.024	1400	14	A-31
6500V Dual HVIGBT																								
QID6508001	6500	85	170	9000	85	15	3.8	—	15	0.95	0.44	TBD	TBD	TBD	TBD	170	—	0.7	0.018	0.100	0.175	900	37	A-38
6500V Dual Common Emitter HVIGBTs																								
QIC6508001	6500	85	170	9000	85	15	3.8	—	15	0.95	0.44	TBD	TBD	TBD	TBD	170	—	0.7	0.018	0.100	0.175	900	37	A-38
6500V Chopper HVIGBTs																								
CM400E2G-130H	6500	400	800	10200	400	15	4.50	—	82	5.0	1.4	1.20	0.35	8.2	0.5	800	4.0	1.0	0.009	0.021	0.033	1350	36	A-38
CM400E4G-130H	6500	400	800	10200	400	15	4.50	—	82	5.0	1.4	1.20	0.35	8.2	0.5	800	4.0	1.0	0.009	0.021	0.033	1350	36	A-38

6500V Single HVIGBTs
CM400HG-130H

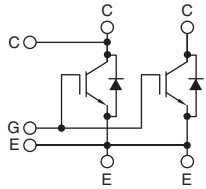

CM200HG-130H, CM600HG-130H, CM750HG-130R

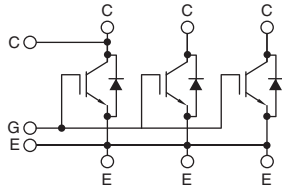

QIS6502002

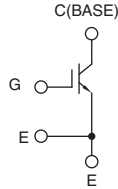

6500V Dual HVIGBT
QID6508001

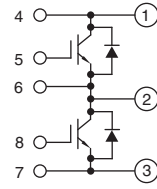

6500V Dual Common Emitter HVIGBT
QIC6508001

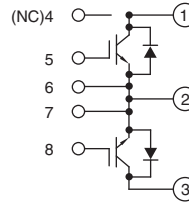

6500V Chopper HVIGBTs
CM400E2G-130H, CM400E4G-130H

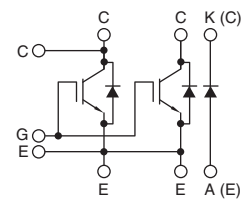

1 CM50RL-24NF, CM50TL-24NF,
CM75TL-12NF, CM150TL-12NF

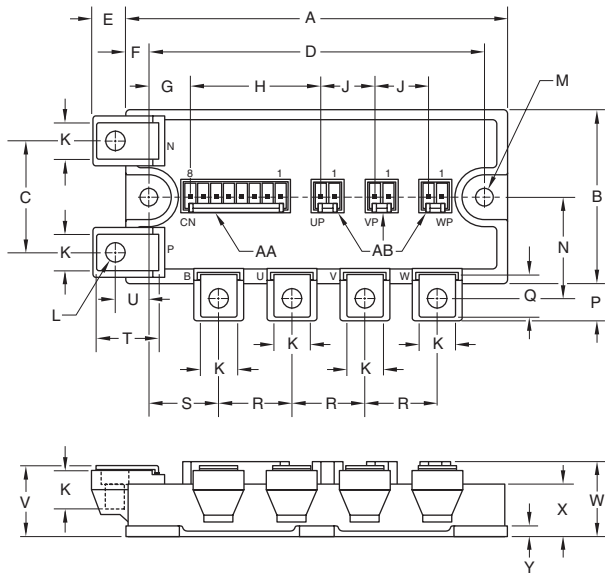

Dim.	Inches	Millimeters	Dim.	Inches	Millimeters
A	4.72	120.0	N	1.23	32.0
B	2.17	55.0	P	0.47	11.75
C	1.39	35.0	Q	0.53	13.5
D	4.17±0.02	106.0±0.5	R	0.91	23.0
E	0.43	11.0	S	0.87	22.0
F	0.28	7.0	T	0.76	19.75
G	0.54	13.62	U	0.42	10.75
H	1.61	40.78	V	0.87+0.04/-0.02	22.0+1.0/-0.5
J	0.67	17.0	W	0.91	23.2
K	0.47	12.0	X	0.63	16.0
L	M5 Metric	M5	Y	0.12	3.0
M	0.22 Dia.	5.5 Dia.			

Housing Types (J.S.T. Mfg. Co. Ltd.)
AA - B8P-VH-FB-B
AB - B2P-VH-FB-B

2 CM600HA-5F

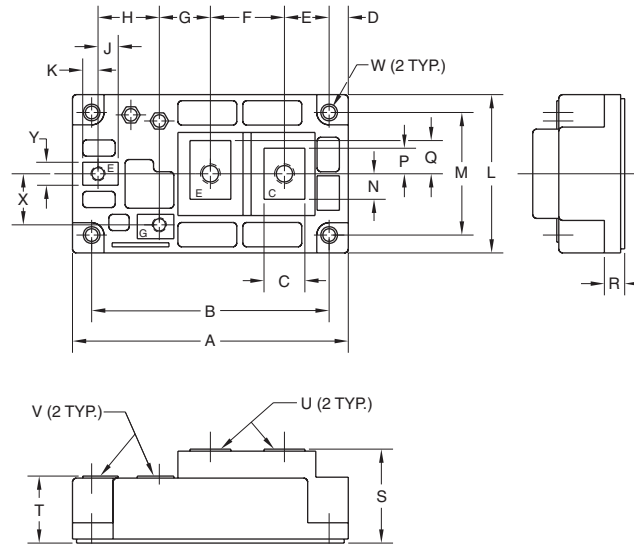

Dim.	Inches	Millimeters	Dim.	Inches	Millimeters
A	4.25	108.0	N	0.39	10.0
B	3.66	93.0	P	0.39	10.0
C	0.63	16.0	Q	0.51	13.0
D	0.30	7.5	R	0.33	8.5
E	0.69	17.5	S	1.42	36.0
F	1.14	29.0	T	1.02	25.8
G	0.79	20.0	U	M6 Metric	M6
H	0.94	24.0	V	M4 Metric	M4
J	0.31	7.9	W	0.22 Dia.	5.5 Dia.
K	0.24	6.0	X	0.79	20.0
L	2.44	62.0	Y	0.35	9.0
M	1.89	48.0			

3 CM200TU-5F

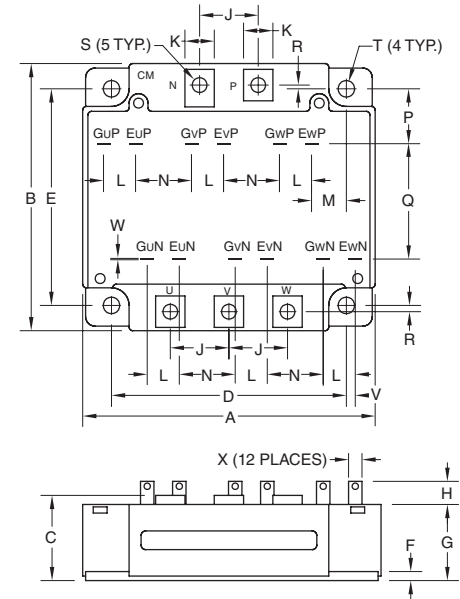

Dim.	Inches	Millimeters	Dim.	Inches	Millimeters
A	4.21	107.0	M	0.57	14.4
B	4.02	102.0	N	0.85	21.7
C	1.14 +0.04/-0.02	29.0 +1.0/-0.5	P	0.67	17.0
D	3.54±0.01	90.0±0.25	Q	1.91	48.5
E	3.15±0.01	80.0±0.25	R	0.15	3.75
F	0.16	4.0	S	M5	M5
G	1.02	26.0	T	0.22 Dia.	5.5 Dia.
H	0.31	8.1	U	0.02	0.5
J	0.91	23.0	V	0.03	0.8
K	0.47	12.0	W	0.02	0.5
L	0.43	11.0	X	0.110	2.8

4 CM400C1Y-24S

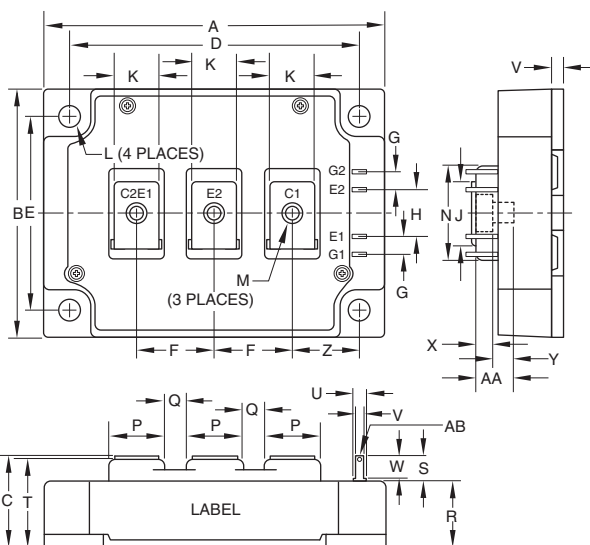

Dim.	Inches	Millimeters	Dim.	Inches	Millimeters
A	4.33	110.0	P	0.71	18.0
B	3.15	80.0	Q	0.28	7.0
C	1.14+0.04/-0.02	29.0+1.0/-0.5	R	0.84	21.2
D	3.66±0.01	93.0±0.25	S	0.33	8.5
E	2.44±0.01	62.0±0.25	T	1.10	28.0
F	0.98	25.0	U	0.16	4.0
G	0.24	6.0	V	0.11	2.8
H	0.59	15.0	W	0.29	7.5
J	0.81	20.5	X	0.21	5.3
K	0.55	14.0	Y	0.26	6.7
L	0.26 Dia.	6.5 Dia.	Z	0.85	21.5
M	M6 Metric	M6	AA	0.47	12.0
N	1.18	30.0	AB	t = 0.02	t = 0.5

5 CM100DY-24NF, CM150DY-12NF, CM200DY-12NF, CM300DY-12NF

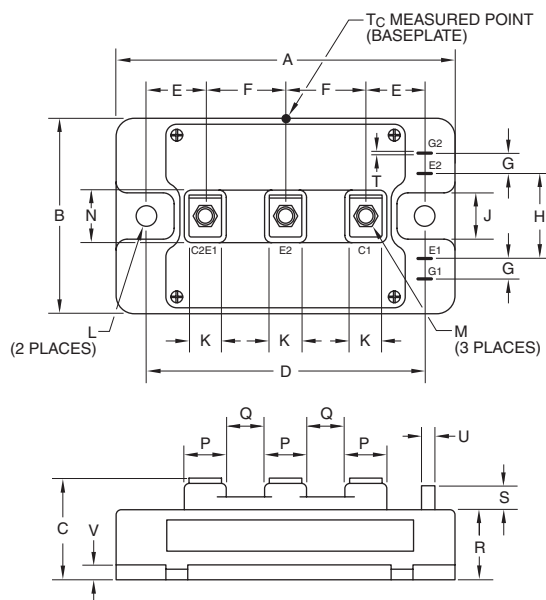

Dim.	Inches	Millimeters	Dim.	Inches	Millimeters
A	3.70	94.0	L	0.26 Dia.	6.5 Dia.
B	1.89	48.0	M	M5 Metric	M5
C	1.14+0.04/-0.02	29.0+1.0/-0.5	N	0.79	20.0
D	3.15±0.01	80.0±0.25	P	0.63	16.0
E	0.67	17.0	Q	0.28	7.0
F	0.91	23.0	R	0.83	21.2
G	0.16	4.0	S	0.30	7.5
H	0.71	18.0	T	0.02	0.5
J	0.51	13.0	U	0.110	2.8
K	0.47	12.0	V	0.16	4.0

6 CM300DY-24S, CM300DY-24NFH, CM300E3Y6-24NFH, CM400DY-12NF, CM400E3Y6-24NFH

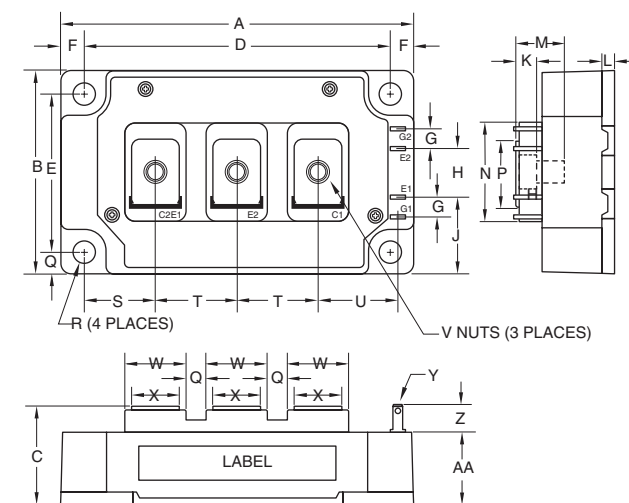

Dim.	Inches	Millimeters	Dim.	Inches	Millimeters
A	4.25	108.0	P	0.79	20.0
B	2.44	62.0	Q	0.28	7.0
C	1.18+0.4/-0.02	30.0+1.0/-0.5	R	0.26 Dia.	6.5 Dia.
D	3.66±0.01	93.0±0.25	S	0.85	21.5
E	1.89±0.01	48.0±0.25	T	0.98	25.0
F	0.29	7.5	U	0.94	24.0
G	0.24	6.0	V	M6 Metric	M6
J	0.689	17.5	V	0.16	4.0
H	0.59	15.0	W	0.71	18.0
K	0.244	6.2	X	0.55	14.0
L	0.16	4.0	Y	0.02	0.5
M	0.56	14.2	Z	0.33	8.5
N	1.18	30.0	AA	0.87	22.2

7 CM600DY-12NF

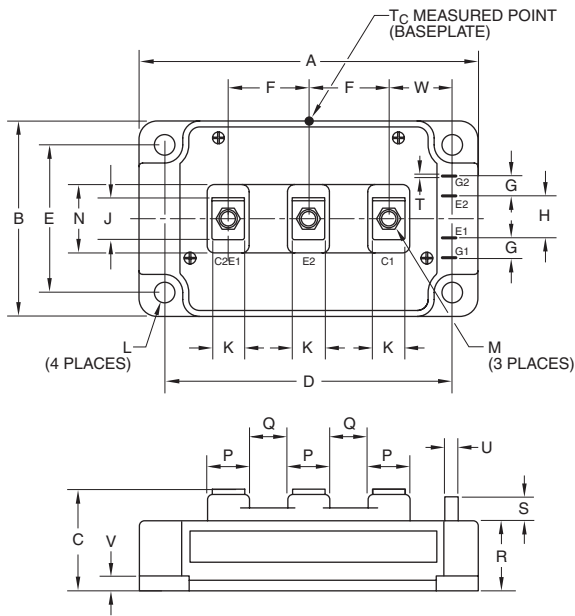

Dim.	Inches	Millimeters
A	4.33	110.0
B	3.15	80.0
C	1.14+0.04/-0.02	29.0+1.0/-0.5
D	3.66±0.01	93.0±0.25
E	2.44±0.01	62.0±0.25
F	0.98	25.0
G	0.24	6.0
H	0.59	15.0
J	0.81	20.5
K	0.55	14.0
L	0.26 Dia.	6.5 Dia.

Dim.	Inches	Millimeters
M	M6 Metric	M6
N	1.18	30.0
P	0.71	18.0
Q	0.28	7.0
R	0.83	21.2
S	0.33	8.5
T	0.02	0.5
U	0.110	2.8
V	0.16	4.0
W	0.85	21.5

8 CM100DUS-12F, CM150DUS-12F

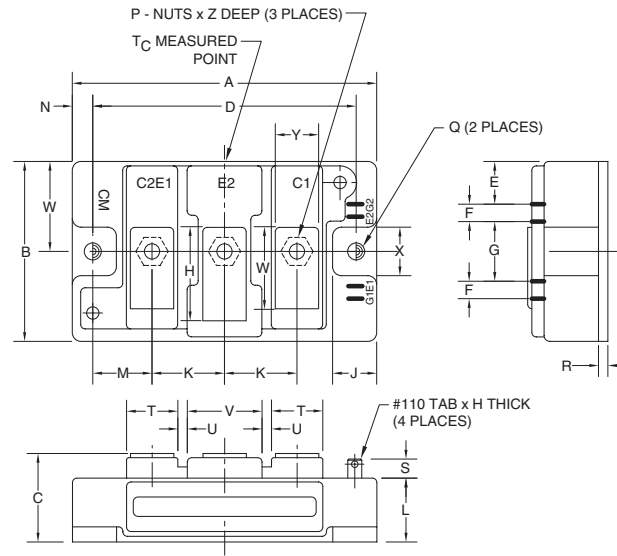

Dim.	Inches	Millimeters
A	3.70	94.0
B	1.89	48.0
C	1.18 +0.04/-0.02	30.0 +1.0/-0.5
D	3.15±0.01	80.0±0.25
E	0.43	11.0
F	0.16	4.0
G	0.71	18.0
H	1.06	27.0
J	0.53	13.5
K	0.91	23.0
L	0.83	21.2
M	0.67	17.0

Dim.	Inches	Millimeters
N	0.28	7.0
P	M6.5 Metric	M6.5
Q	0.26 Dia.	6.5 Dia.
R	0.02	4.0
S	0.30	7.5
T	0.63	16.0
U	0.10	2.5
V	1.0	25.0
W	0.94	24.0
X	0.51	13.0
Y	0.47	12.0
Z	0.47	12.0

9 CM400DY-34A

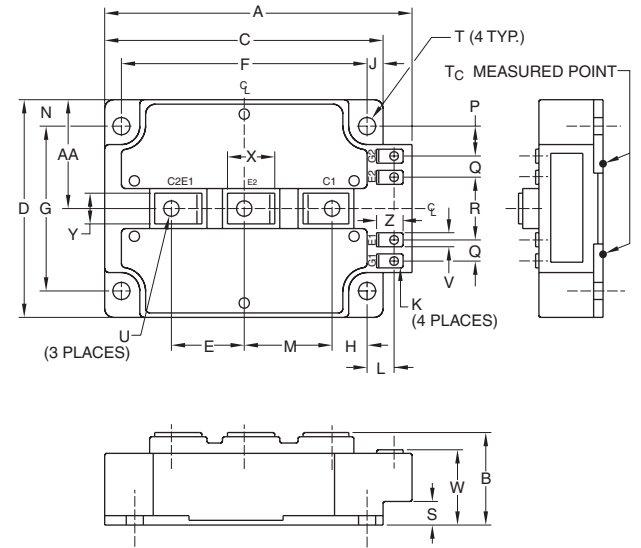

Dim.	Inches	Millimeters
A	5.51	140.0
B	1.38+0.04/-0.02	35.0+1.0/-0.5
C	5.12	130.0
D	5.12	130.0
E	1.42	36.0
F	4.33±0.01	110.0±0.25
G	4.33±0.01	110.0±0.25
H	0.54	13.8
J	0.39	10.0
K	M4 Metric	M4
L	0.45	11.5
M	1.72	43.8
N	0.39	10.0

Dim.	Inches	Millimeters
P	0.80	20.4
Q	0.57	14.5
R	1.57	40.0
S	0.31	8.0
T	0.26 Dia.	6.5 Dia.
U	M8 Metric	M8
V	0.35	9.0
W	0.96+0.04/-0.02	24.5+1.0/-0.5
X	1.02	26.0
Y	0.79	20.0
Z	0.59	15.0
AA	2.56	65.0

10 CM150DX-24S, CM300DX1-24NFJ,
QID0640020, QID1230015, QIS066004, QIS1260015

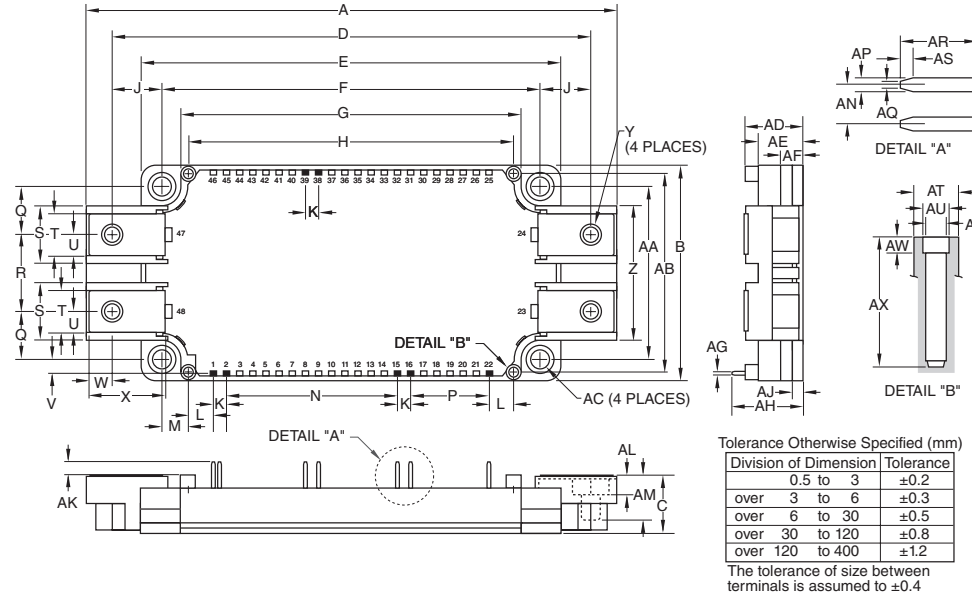

Dim.	Inches	Millimeters
A	5.98	152.0
B	2.44	62.0
C	0.67+0.04/-0.02	17.0+1.0/-0.5
D	5.39	137.0
E	4.79	121.7
F	4.33±0.02	110.0±0.5
G	3.89	99.0
H	3.72	94.5
J	0.53	13.5
K	0.15	3.81
L	0.28	7.25
M	0.30	7.75
N	1.95	49.53
P	0.9	22.86
Q	0.55	14.0
R	0.87	22.0

Dim.	Inches	Millimeters
S	0.67	17.0
T	0.48	12.0
U	0.24	6.0
V	0.16	4.2
W	0.37	6.5
X	0.83	21.14
Y	M6 Metric	M6
Z	1.53	39.0
AA	1.97±0.02	50.0±0.5
AB	2.26	57.5
AC	0.22 Dia.	5.5 Dia.
AD	0.67+0.04/-0.02	17.0+1.0/-0.5
AE	0.51	13.0
AF	0.27	7.0
AG	0.03	0.8

Dim.	Inches	Millimeters
AH	0.81	20.5
AJ	0.12	3.0
AK	0.14	3.5
AL	0.26	6.5
AM	0.53	13.5
AN	0.15	3.81
AP	0.05	1.15
AQ	0.025	0.65
AR	0.29	7.4
AS	0.05	1.2
AT	0.17 Dia.	4.3 Dia.
AU	0.102 Dia.	2.6 Dia.
AV	0.088 Dia.	2.25 Dia.
AW	0.12	3.0
AX	0.49	12.5

11 CM75RX-24S, CM100RX-12A, CM150RX-12A, CM200RX-12A

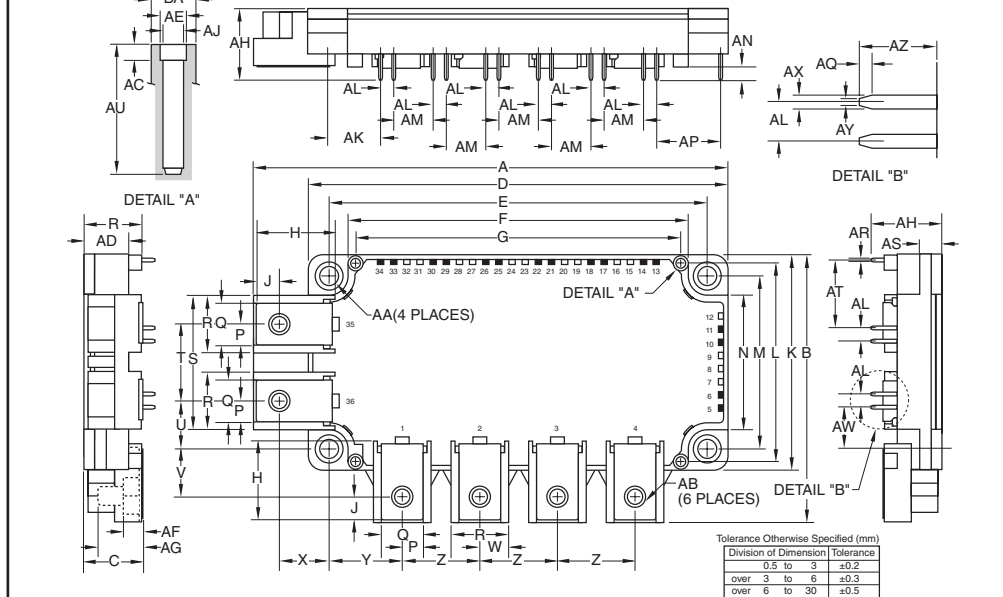

Dim.	Inches	Millimeters
A	5.39	136.9
B	3.03	77.1
C	0.67+0.04/-0.02	17.0+1.0/-0.5
D	4.79	121.7
E	4.33±0.02	110.0±0.5
F	3.89	99.0
G	3.72	94.5
H	0.83	21.14
J	0.37	6.5
K	2.44	62.0
L	2.26	57.5
M	1.97±0.02	50.0±0.5
N	1.53	39.0
P	0.24	6.0
Q	0.48	12.0
R	0.67	17.0
S	1.53	39.0

Dim.	Inches	Millimeters
T	0.87	22.0
U	0.55	14.0
V	0.54	13.64
W	0.33	8.5
X	0.53	13.5
Y	0.81	20.71
Z	0.9	22.86
AA	0.22 Dia.	5.5 Dia.
AB	M5 Metric	M5
AC	0.12	3.0
AD	0.51	13.0
AE	0.102 Dia.	2.6 Dia.
AF	0.21	5.4
AG	0.49	12.5
AH	0.81	20.5
AJ	0.088 Dia.	2.25 Dia.

Dim.	Inches	Millimeters
AK	0.59	15.00
AL	0.15	3.81
AM	0.45	11.43
AN	0.14	3.5
AP	0.75	19.05
AQ	0.05	1.2
AR	0.03	0.8
AS	0.27	7.0
AT	0.77	19.68
AU	0.49	12.5
AV	0.60	15.24
AW	0.46	11.66
AX	0.04	1.15
AY	0.02	0.65
AZ	0.29	7.4
BA	0.17 Dia.	4.3 Dia.

12 CM75RX-34SA

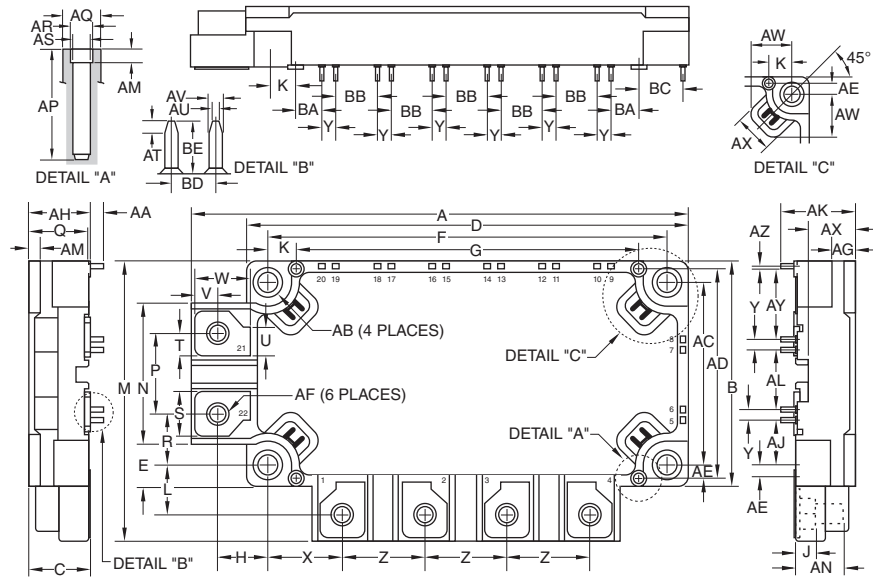

Dim.	Inches	Millimeters	Dim.	Inches	Millimeters	Dim.	Inches	Millimeters
A	5.39	136.9	U	0.31	8.0	AN	0.53	13.4
B	2.44	62.0	V	0.37	6.5	AP	0.49	12.5
C	0.67+0.04/-0.02	17.0+1.0/-0.5	W	0.61	15.64	AQ	0.18 Dia.	4.5 Dia.
D	4.79	121.7	X	0.81	20.71	AR	0.102 Dia.	2.6 Dia.
E	0.45	11.5	Y	0.15±0.008	3.81±0.2	AS	0.088 Dia.	2.25 Dia.
F	4.33±0.02	110.0±0.5	Z	0.9	22.86	AT	0.05	1.2
G	3.72	94.5	AA	0.14	3.5	AU	0.02	0.65
H	0.53	13.5	AB	0.22 Dia.	5.5 Dia.	AV	0.04	1.15
J	0.23	5.9	AC	1.97±0.02	50.0±0.5	AW	0.54	13.7
K	0.30	7.75	AD	2.26	57.5	AX	0.51	13.0
L	0.53	13.64	AE	0.14	3.75	AY	0.75	19.12
M	3.02	77.1	AF	M5	M5	AZ	0.021±0.008	0.55±0.2
N	1.53	39.0	AG	0.27	7.0	BA	0.28±0.008	7.24±0.2
P	0.87	22.0	AH	0.67	17.0	BB	0.43±0.008	11.42±0.2
Q	0.65	16.5	AJ	0.44±0.008	11.67±0.2	BC	0.46±0.008	11.8±0.2
R	0.55	14.0	AK	0.81	20.5	BD	0.15	3.81
S	0.47	12.0	AL	0.60±0.008	15.24±0.2	BE	0.18	4.5
T	0.24	6.0	AM	0.12	3.0			

13 CM75TX-24S

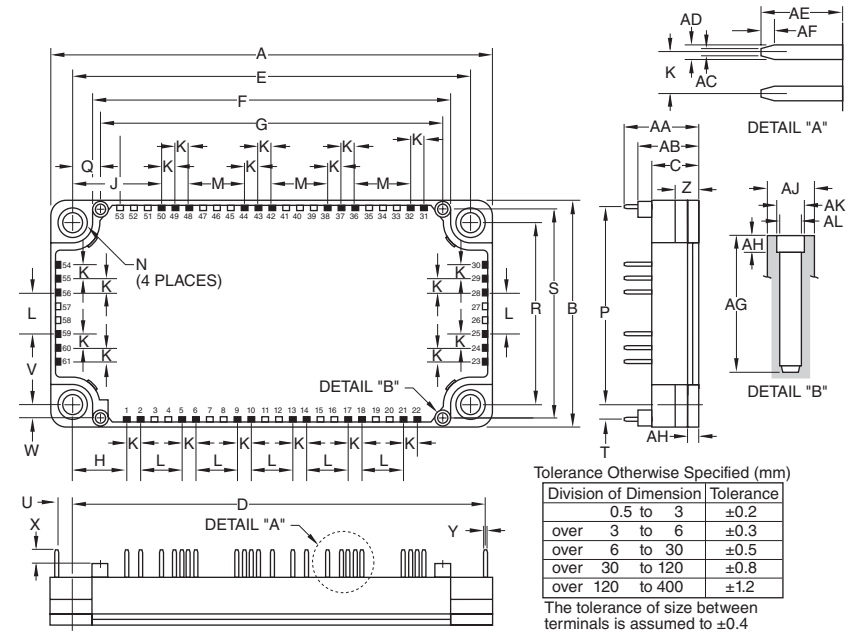

Dim.	Inches	Millimeters	Dim.	Inches	Millimeters	Dim.	Inches	Millimeters
A	4.79	121.7	N	0.22 Dia.	5.5 Dia.	AA	0.81	20.5
B	2.44	62.0	P	2.13	54.2	AB	0.67	17.0
C	0.51	13.0	Q	0.30	7.75	AC	0.03	0.65
D	4.49	114.05	R	1.97±0.02	50.0±0.5	AD	0.05	1.15
E	4.33±0.02	110.0±0.5	S	2.26	57.5	AE	0.29	7.4
F	3.9	99.0	T	0.165	4.2	AF	0.047	1.2
G	3.72	94.5	U	0.16	4.06	AG	0.49	12.5
H	0.59	15.0	V	0.46	11.66	AH	0.12	3.0
J	0.96	24.52	W	0.14	3.75	AJ	0.17 Dia.	4.3 Dia.
K	0.15	3.81	X	0.14	3.5	AK	0.102 Dia.	2.6 Dia.
L	0.45	11.43	Y	0.03	0.8	AL	0.088 Dia.	2.25 Dia.
M	0.6	15.24	Z	0.28	7.0			

14 CM750HG-130H, CM1200HG-90R, CM1500HG-66R

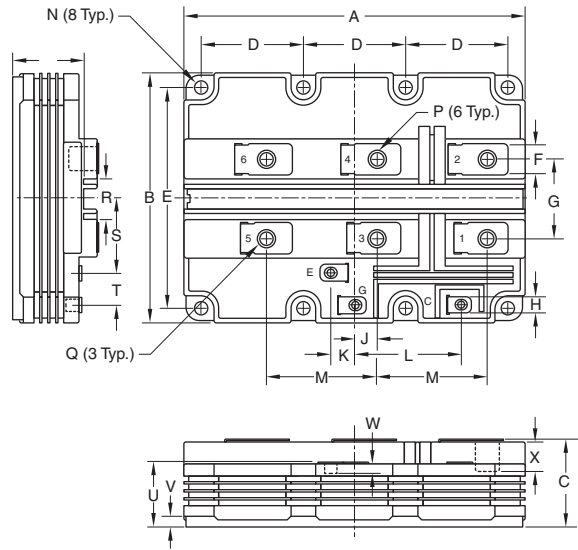

Dim.	Inches	Millimeters
A	7.5±0.02	190.0±0.5
B	5.51±0.02	140.0±0.5
C	1.88+0.04/-0.02	48.0+1.0/-0.5
D	2.24±0.01	57.0±0.25
E	4.88±0.01	124.0±0.25
F	0.67+0.04/-0.02	17.0+1.0/-0.5
G	1.73±0.012	44.0±0.3
H	0.35±0.008	9.0±0.2
J	0.47±0.012	12.0±0.3
K	0.55±0.012	14.0±0.3
L	2.33±0.012	59.2±0.3

Dim.	Inches	Millimeters
M	2.42±0.012	61.2±0.3
N	0.28 Dia.	7.0 Dia.
P	M8 Metric	M8
Q	M4 Metric	M4
R	0.86±0.012	22.0±0.3
S	1.61±0.012	41.0±0.3
T	0.71±0.012	18.0±0.3
U	1.50±0.02	38.0±0.5
V	0.20±0.008	5.0±0.2
W	0.30 Min.	7.7 Min.
X	0.65 Min.	16.5 Min.

15 CM800HC-90R

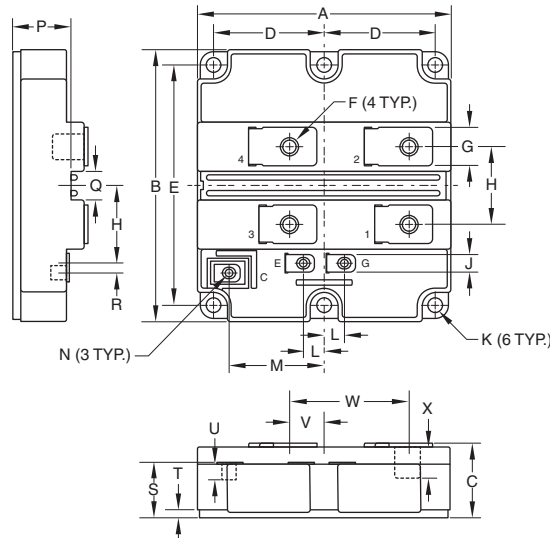

Dim.	Inches	Millimeters
A	2.54±0.02	130.0±0.5
B	5.51±0.02	140.0±0.5
C	1.50+0.04/-0.02	38.0+1.0/-0.5
D	2.24±0.01	57.0±0.25
E	4.88±0.01	124.0±0.25
F	M8 Metric	M8
G	0.78±0.012	20.0±0.3
H	1.57±0.012	40.0±0.3
J	0.35±0.008	9.0±0.2
K	0.28 Dia.	7.0 Dia.
L	0.092±0.012	10.65±0.3

Dim.	Inches	Millimeters
M	1.92±0.012	48.8±0.3
N	M4 Metric	M4
P	1.16±0.02	29.5±0.5
Q	0.59±0.012	15.0±0.3
R	0.86±0.012	22.0±0.3
S	1.10±0.02	28.0±0.5
T	0.20±0.008	5.0±0.2
U	0.30 Min.	7.7 Min.
V	0.71±0.012	18.0±0.3
W	2.42±0.012	61.5±0.3
X	0.65 Min.	16.5 Min.

16 CM450DY-24S, CM600DY-24S

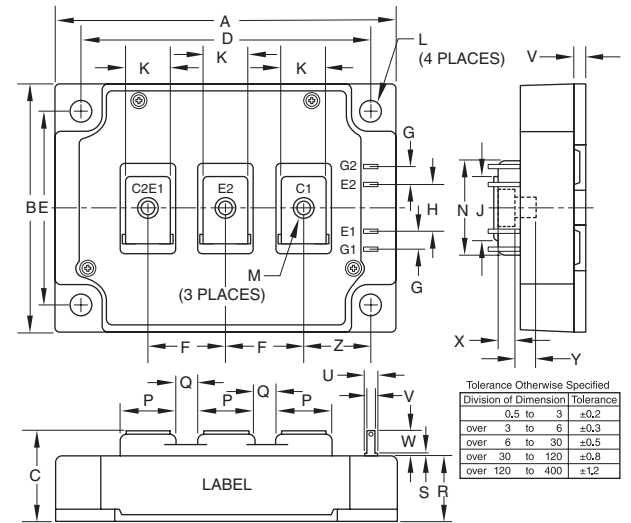

Tolerance Otherwise Specified		
Division of Dimension	3	±0.2
0.5 to 3	±0.3	
over 3 to 6	±0.5	
over 6 to 30	±0.8	
over 30 to 120	±1.2	
over 120 to 400	±1.2	

Dim.	Inches	Millimeters
A	4.33	110.0
B	3.15	80.0
C	1.14+0.04/-0.02	29.0+1.0/-0.5
D	3.66±0.01	93.0±0.25
E	2.44±0.01	62.0±0.25
F	0.98	25.0
G	0.24	6.0
H	0.59	15.0
J	0.81	20.5
K	0.55	14.0
L	0.26 Dia.	Dia. 6.5
M	M6 Metric	M6

Dim.	Inches	Millimeters
N	1.18	30.0
P	0.71	18.0
Q	0.28	7.0
R	0.83	21.2
S	0.33	8.5
T	0.0157	0.4
U	0.110	2.8
V	0.16	4.0
W	0.30	7.5
X	0.21	5.3
Y	0.47	12.0
Z	0.85	21.5

17 CM1200HC-90R

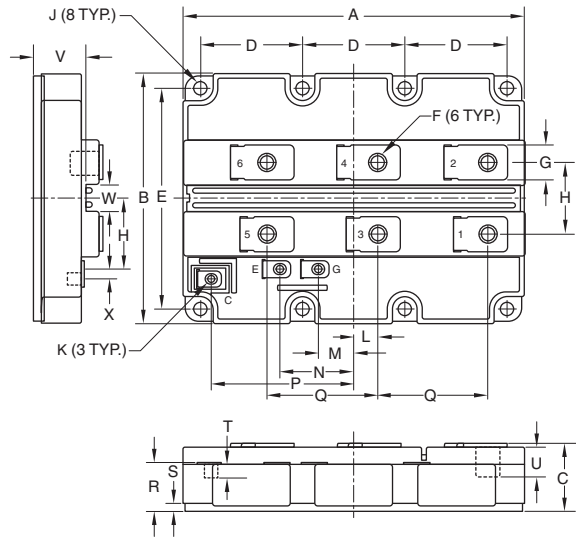

Dim.	Inches	Millimeters
A	7.5±0.02	190.0±0.5
B	5.51±0.02	140.0±0.5
C	1.50+0.04/-0.02	38.0+1.0/-0.5
D	2.24±0.01	57.0±0.25
E	4.88±0.01	124.0±0.25
F	M8 Metric	M8
G	0.78+0.04/-0.02	20.0+1.0/-0.5
H	1.57±0.012	40.0±0.3
J	0.28 Dia.	7.0 Dia.
K	M4 Metric	M4
L	0.51±0.012	13.0±0.3

Dim.	Inches	Millimeters
M	0.79±0.012	20.25±0.3
N	1.62±0.012	41.25±0.3
P	3.12±0.012	79.4±0.3
Q	2.42±0.012	61.5±0.3
R	1.10±0.02	28.0±0.5
S	0.20±0.008	5.0±0.2
T	0.30 Min.	7.7 Min.
U	0.65 Min.	16.5 Min.
V	0.20±0.008	5.0±0.2
W	0.59±0.02	15.0±0.5
X	0.20±0.012	5.2±0.3

18 CM100DU-24NFH, CM150DU-24NFH, CM200DU-12NFH

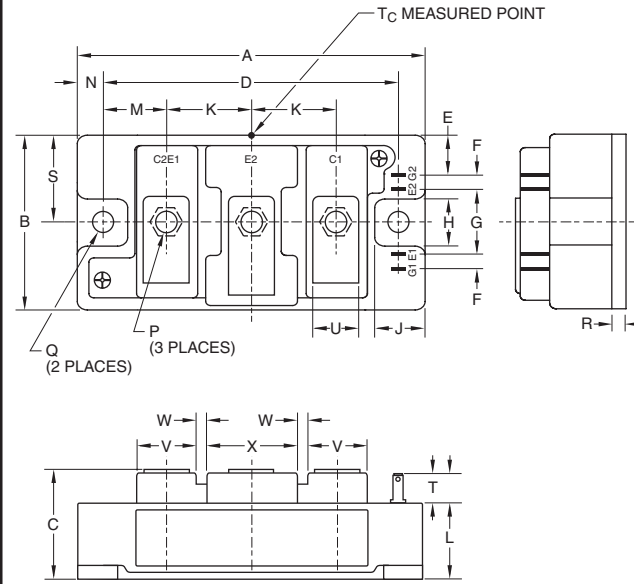

Dim.	Inches	Millimeters
A	3.70	94.0
B	1.89	48.0
C	1.18+0.004/-0.02	30.0+1.0/-0.5
D	3.15±0.01	80.0±0.25
E	0.43	11.0
F	0.16	4.0
G	0.71	18.0
H	0.51	13.0
J	0.53	13.5
K	0.91	23.0
L	0.83	21.2

Dim.	Inches	Millimeters
M	0.67	17.0
N	0.28	7.0
P	M5 Metric	M5
Q	0.26 Dia.	6.5 Dia.
R	0.02	4.0
S	0.94	24.0
T	0.3	7.5
U	0.47	12.0
V	0.63	16.0
W	0.1	2.5
X	0.98	25.0

19 CM200DU-24NFH, CM300DU-12NFH, CM300DU-24NFH, CM400DU-12NFH, CM600E3U-12NFH

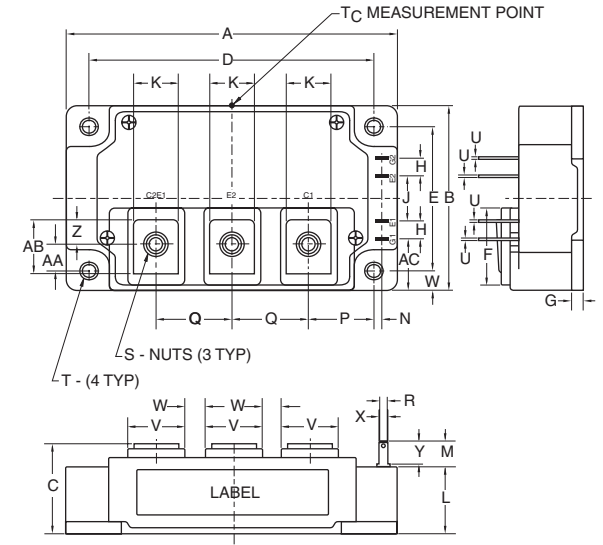

Dim.	Inches	Millimeters
A	4.25	108.0
B	2.44	62.0
C	1.14+0.04/-0.02	29.0+1.0/-0.5
D	3.66±0.01	93.0±0.25
E	1.88±0.01	48.0±0.25
F	0.67	25.7
G	0.16	4.0
H	0.24	6.0
J	0.59	15.0
K	0.55	14.0
L	0.87	22.0
M	0.33	8.5
N	0.10	2.5
P	0.85	21.5

Dim.	Inches	Millimeters
Q	0.98	25.0
R	0.110	2.8
S	M6 Metric	M6
T	0.26 Dia.	6.5 Dia.
U	0.002	0.5
V	0.71	18.0
W	0.28	7.0
X	0.16	4.0
Y	0.3	7.5
Z	0.325	8.25
AA	0.624	8.85
AB	0.709	18.0
AC	0.69	17.5

20 CM75DY-34A, CM100DY-24A, CM100DY-34A, CM150DY-34A

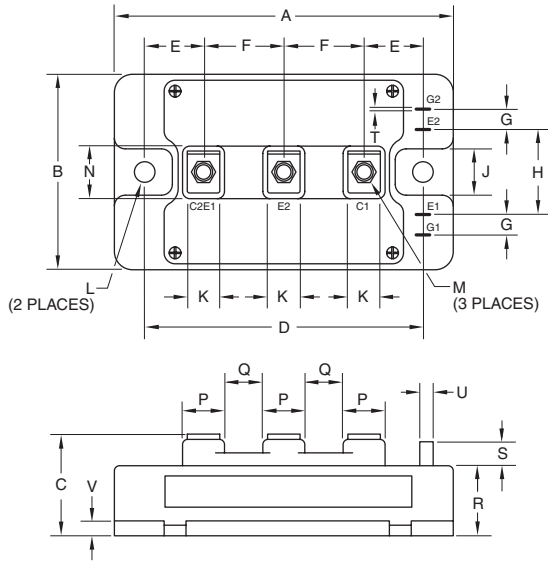

Dim.	Inches	Millimeters
A	3.70	94.0
B	1.89	48.0
C	1.14+0.04/-0.02	29.0+1.0/-0.5
D	3.15±0.01	80.0±0.25
E	0.67	17.0
F	0.91	23.0
G	0.16	4.0
H	0.71	18.0
J	0.51	13.0
K	0.47	12.0

Dim.	Inches	Millimeters
L	0.26 Dia.	6.5 Dia.
M	M5 Metric	M5
N	0.79	20.0
P	0.63	16.0
Q	0.28	7.0
R	0.83	21.2
S	0.30	7.5
T	0.02	0.5
U	0.110	2.8
V	0.16	4.0

21 CM200DY-34A

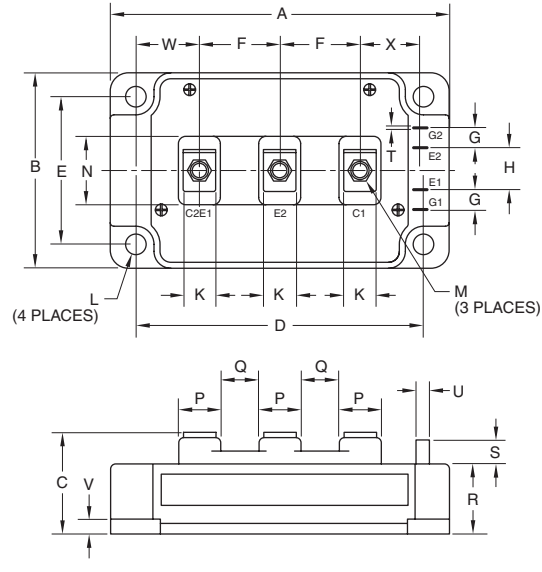

Dim.	Inches	Millimeters
A	4.25	108.0
B	2.44	62.0
C	1.18+0.04/-0.02	30.0+1.0/-0.5
D	3.66±0.01	93.0±0.25
E	1.89±0.01	48.0±0.25
F	0.98	25.0
G	0.24	6.0
H	0.59	15.0
K	0.55	14.0
L	0.26 Dia.	6.5 Dia.
M	M6 Metric	M6

Dim.	Inches	Millimeters
N	1.18	30.0
P	0.71	18.0
Q	0.28	7.0
R	0.87	22.2
S	0.33	8.5
T	0.02	0.5
U	0.110	2.8
V	0.16	4.0
W	0.85	21.5
X	0.94	24.0

22 CM300DY-34A, CM600DY-24A

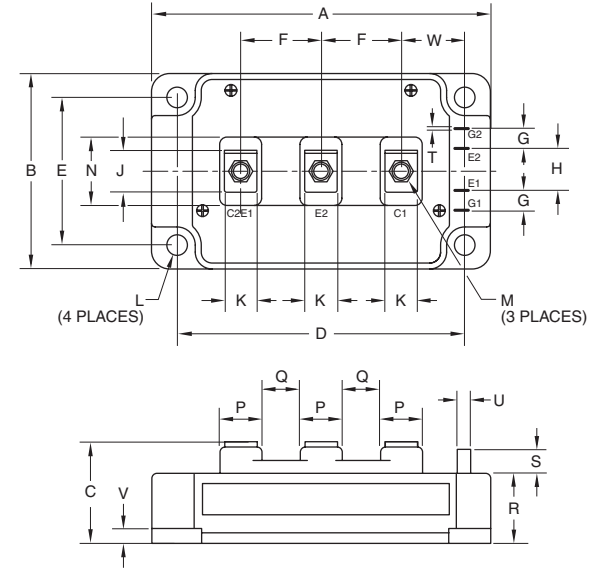

Dim.	Inches	Millimeters
A	4.33	110.0
B	3.15	80.0
C	1.14+0.04/-0.02	29.0+1.0/-0.5
D	3.66±0.01	93.0±0.25
E	2.44±0.01	62.0±0.25
F	0.98	25.0
G	0.24	6.0
H	0.59	15.0
J	0.81	20.5
K	0.55	14.0
L	0.26 Dia.	6.5 Dia.

Dim.	Inches	Millimeters
M	M6 Metric	M6
N	1.18	30.0
P	0.71	18.0
Q	0.28	7.0
R	0.83	21.2
S	0.33	8.5
T	0.02	0.5
U	0.110	2.8
V	0.16	4.0
W	0.85	21.5

23 CM900DUC-24S, CM1000DUC-34SA, CM1000E3U-34NF, CM1400DUC-24S

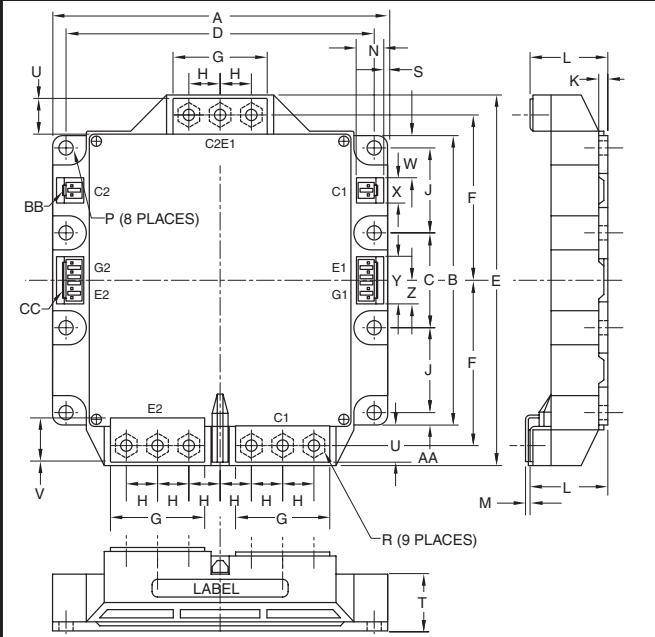

Dim.	Inches	Millimeters	Dim.	Inches	Millimeters
A	5.91	150.0	M	0.075±0.008	1.9±0.2
B	5.10	129.5	N	0.47	12.0
C	1.67±0.01	42.5±0.25	P	0.26	6.5
D	5.41±0.01	137.5±0.25	R	M6 Metric	M6
E	6.54	166.0	S	0.08	2.0
F	2.91±0.01	74.0±0.25	T	0.99	25.1
G	1.65	42.0	U	0.62	15.7
H	0.55	14.0	V	0.71	18.0
J	1.50±0.01	38.0±0.25	W	0.75	19.0
K	0.16	4.0	X	0.43	11.0
L	1.36 +0.04/-0.02	34.6 +1.0/-0.5	Y	0.83	21.0
Housing Type (J.S.T. MFG. CO. LTD)			Z	0.41	10.5
BB = VHR-2N			AA	0.22	5.5
CC = VHR-5N					

24 CM400DU-24NFH, CM400DU-24NFJ, CM600DU-12NFH, CM600DU-24NFH

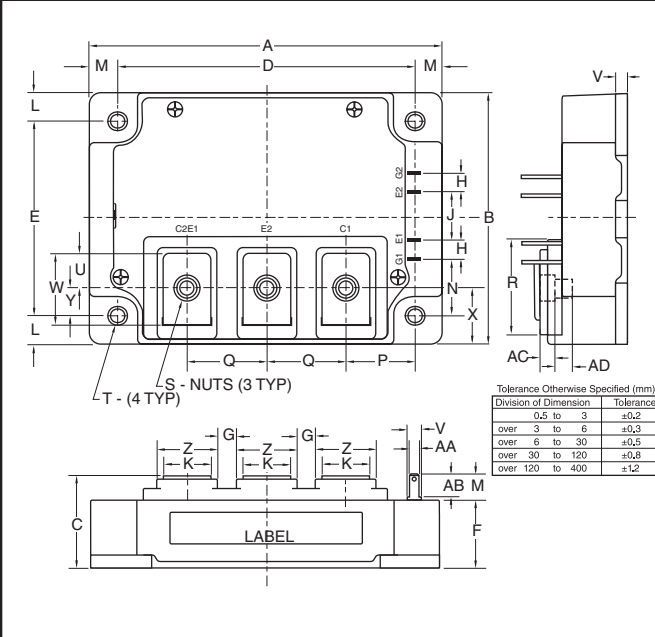

Tolerance Otherwise Specified (mm)

Division of Dimension	Tolerance
0.5 to 3	±0.2
over 3 to 6	±0.3
over 6 to 30	±0.5
over 30 to 120	±0.8
over 120 to 400	±1.2

Dim.	Inches	Millimeters	Dim.	Inches	Millimeters
A	4.33	110.0	Q	0.98	25.0
B	3.15	80.0	R	1.23	31.4
C	1.14+0.04/-0.01	29.0+1.0/-0.5	S	M6 Metric	M6
D	3.66±0.01	93.0±0.25	T	0.26 Dia.	6.5 Dia.
E	2.44±0.01	62.0±0.25	U	0.4	10.0
F	0.83	21.2	V	0.16	4.0
G	0.28	7.0	W	0.87	22.2
H	0.24	6.0	X	0.72	18.25
J	0.59	15.0	Y	0.36	9.25
K	0.55	14.0	Z	0.71	18.0
L	0.35	9.0	AA	0.11	2.8
M	0.33	8.5	AB	0.29	7.5
N	0.69	17.5	AC	0.21	5.3
P	0.85	21.5	AD	0.47	12.0

25 CM800DY-24S

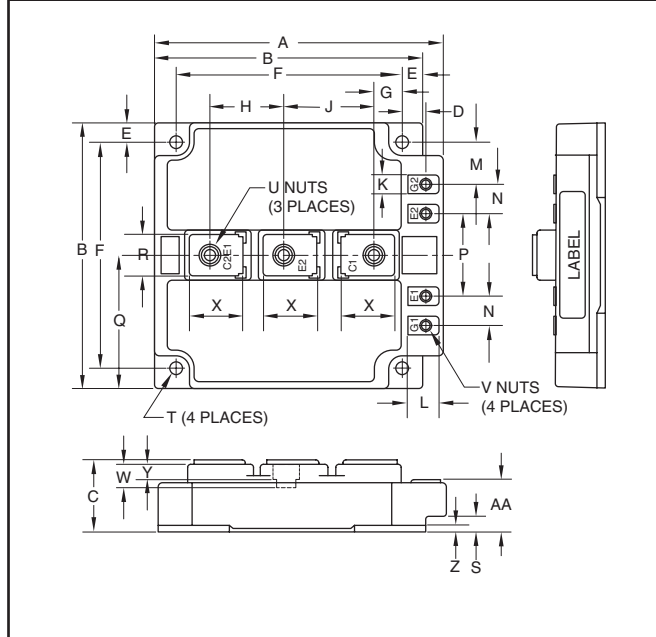

Dim.	Inches	Millimeters	Dim.	Inches	Millimeters
A	5.51	140.0	P	1.57	40.0
B	5.12	130.0	Q	2.56	65.0
C	1.38+0.04/-0.02	35.0+1.0/-0.5	R	0.79	20.0
D	0.45	11.5	S	0.32	8.0
E	0.39	10.0	T	0.26 Dia.	6.5 Dia.
F	4.33±0.001	110.0±0.25	U	M8 Metric	M8
G	0.54	13.8	V	M4 Metric	M4
H	1.42	36.0	W	0.43	11.1
J	1.72	43.8	X	1.02	26.0
K	0.35	9.0	Y	0.29	7.3
L	0.59	15.0	Z	0.16	4.0
M	0.80	20.4	AA	0.96+0.04/-0.02	24.5+1.0/-0.5
N	0.57	14.5			

26 CM800HA-34H, CM1200HA-34H

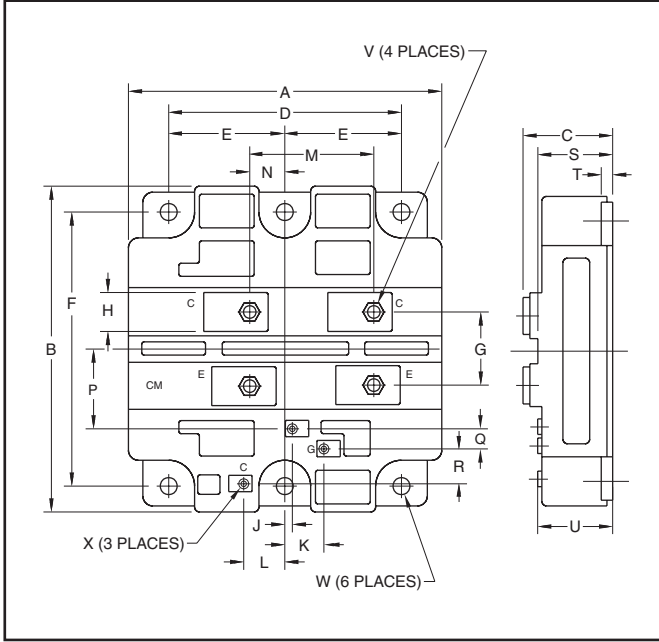

Dim.	Inches	Millimeters	Dim.	Inches	Millimeters
A	5.12	130.0	M	2.42	61.5
B	5.51	140.0	N	0.71	18.0
C	1.50+0.04/-0	38.0+1.0/-0	P	1.38	35.0
D	4.49	114.0	Q	0.43	11.0
E	2.24±0.01	57.0±0.25	R	0.57	14.5
F	4.88±0.01	124.0±0.25	S	1.24	31.5
G	1.18	30.0	T	0.20	5.0
H	0.79	20.0	U	1.10+0.04/-0	28.0+1.0/-0
J	0.10	2.5	V	M8 Metric	M8
K	0.73	18.5	W	0.28 Dia.	7.0 Dia.
L	0.65	16.5	X	M4 Metric	M4

27 CM1200E4C-34N, CM1800HC-34N, CM2400HC-34N

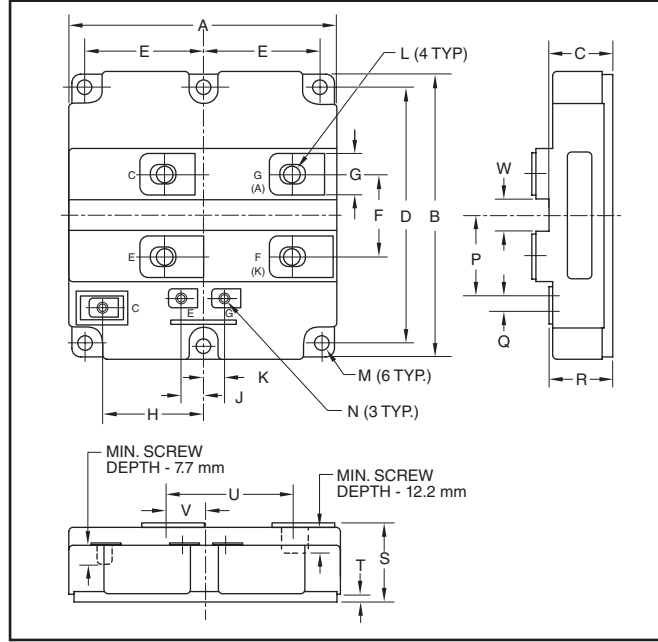

Dim.	Inches	Millimeters	Dim.	Inches	Millimeters
A	5.12±0.02	130.0±0.5	M	0.28 Dia.	7.0 Dia.
B	5.51±0.02	140.0±0.5	N	M4 Metric	M4
C	1.16±0.02	29.5±0.5	P	1.57±0.008	40.0±0.2
D	4.88±0.004	124.0±0.1	Q	0.25±0.008	5.2±0.2
E	2.24±0.004	57.0±0.1	R	0.10+0.039/-0.0	28.0+1.0/-0.0
F	1.57±0.008	40.0±0.2	S	1.45+0.039/-0.0	38.0+1.0/-0.0
G	0.79±0.004	20.0±0.1	T	0.20±0.008	5.0±0.2
H	1.92±0.008	48.8±0.2	U	2.42±0.012	61.5±0.3
J	0.42±0.008	10.65±0.2	V	0.71±0.008	18.0±0.2
K	0.41±0.008	10.35±0.2	W	0.59±0.008	15.0±0.2
L	M8 Metric	M8			

28 CM1200DC-34S, CM1200DB-34N, CM1200DC-34N

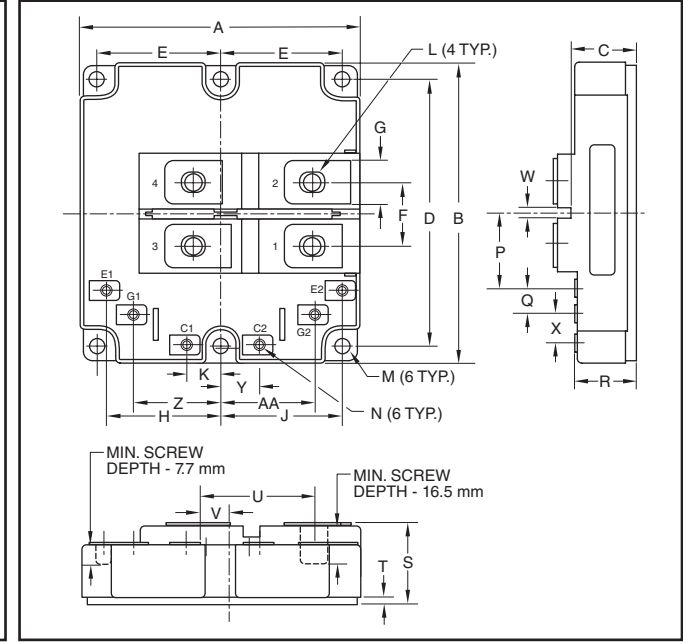

Dim.	Inches	Millimeters	Dim.	Inches	Millimeters
A	5.12±0.02	130.0±0.5	P	1.38±0.008	35.0±0.2
B	5.51±0.02	140.0±0.5	Q	0.2±0.008	5.0±0.2
C	1.16±0.02	29.5±0.5	R	0.10+0.039/-0.0	28.0+1.0/-0.0
D	4.88±0.009	124.0±0.25	S	1.45+0.039/-0.0	38.0+1.0/-0.0
E	2.24±0.009	57.0±0.25	T	0.20±0.008	5.0±0.2
F	1.18±0.008	30.0±0.2	U	2.17±0.012	55.2±0.3
G	0.79±0.004	20.0±0.1	V	0.466±0.008	11.85±0.2
H	2.09±0.008	53.0±0.2	W	0.2±0.008	5.0±0.2
J	2.24±0.008	57.0±0.2	X	0.55±0.008	14.0±0.2
K	0.63±0.008	16.0±0.2	Y	0.71±0.008	18.0±0.2
L	M8 Metric	M8	Z	1.57±0.008	40.0±0.2
M	0.28 Dia.	7.0 Dia.	AA	1.73±0.008	44.0±0.2
N	M4 Metric	M4			

29 CM400HA-24A, CM500HA-34A, CM600HA-24A

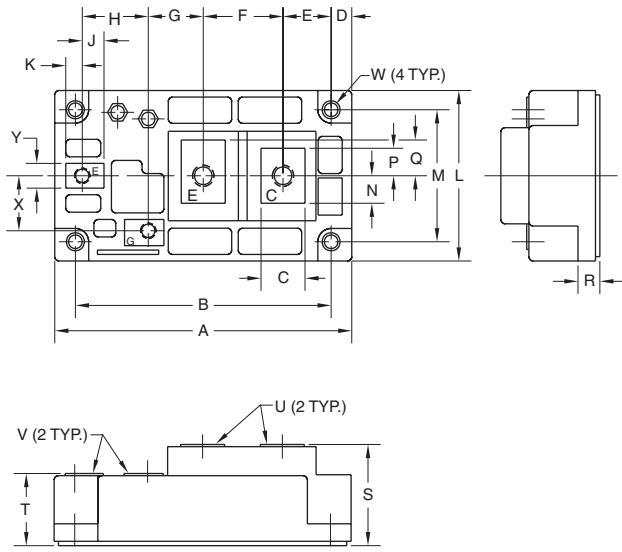

Dim.	Inches	Millimeters	Dim.	Inches	Millimeters
A	4.25	108.0	N	0.39	10.0
B	3.66	93.0	P	0.39	10.0
C	0.63	16.0	Q	0.51	13.0
D	0.30	7.5	R	0.33	8.5
E	0.69	17.5	S	1.42	36.0
F	1.14	29.0	T	1.02	25.8
G	0.79	20.0	U	M6 Metric	M6
H	0.94	24.0	V	M4 Metric	M4
J	0.31	7.9	W	0.256 Dia.	6.5 Dia.
K	0.24	62.0	X	0.79	20.0
L	2.44	62.0	Y	0.35	9.0
M	1.89	48.0			

30 CM800E2C-66H, CM800E6C-66H, CM900HB-90H,
CM900HC-90H, CM1000E4C-66R, CM1200HC-66H,
CM1500HC-66R, CM1800HCB-34N, CM2400HCB-34N

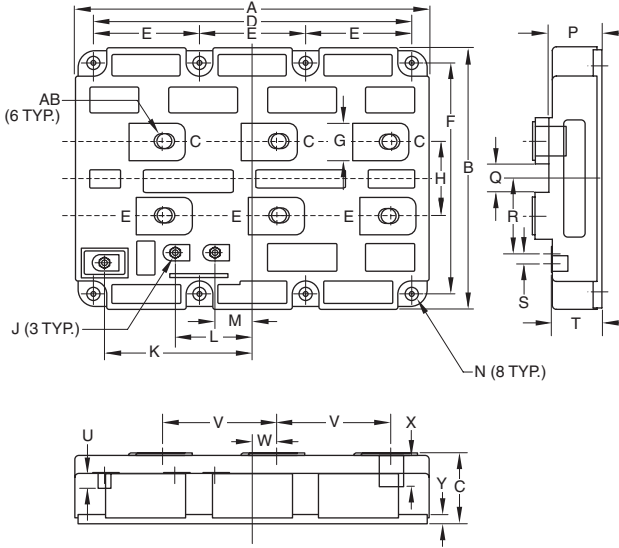

Dim.	Inches	Millimeters	Dim.	Inches	Millimeters
A	7.5±0.02	190.0±0.5			
B	5.51±0.02	140.0±0.5			
C	1.50+0.04/-0	38.0+1.0/-0			
D	6.73	171.0			
E	2.24±0.004	57.0±0.1			
F	4.88±0.004	124.0±0.1			
G	0.79+0.039/-0.008	20.0+1.0/-0.2			
H	1.57±0.008	40.0±0.2			
J	M4 Metric	M4			
K	3.13±0.012	79.4±0.3			
L	1.62±0.012	41.25±0.3			
M	0.80±0.008	20.25±0.2			

31 CM600DY-34H, CM800DZ-34H

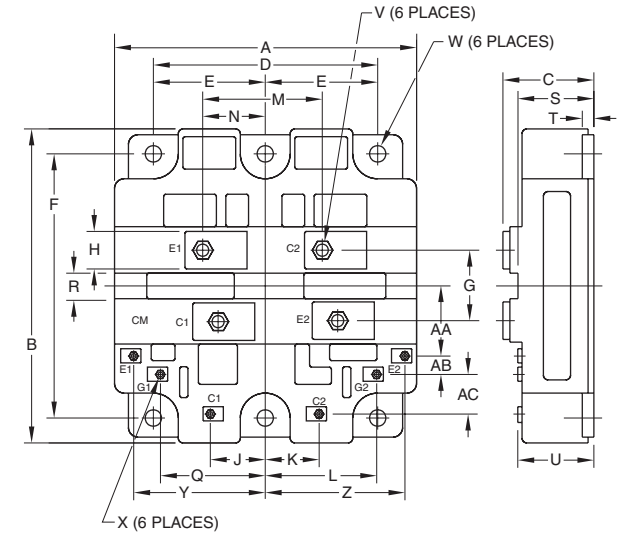

Dim.	Inches	Millimeters	Dim.	Inches	Millimeters
N	0.27 Dia.	7.0 Dia.	Q	1.58	40.0
P	1.16±0.02	29.5±0.5	R	0.20	5.0
Q	0.59±0.008	15.0±0.2	C	1.50+0.08/-0	38.0+2.0/-0
R	1.57±0.012	40.0±0.3	D	4.49	114.0
S	0.20±0.008	5.2±0.2	E	2.24±0.01	57.0±0.25
T	1.10+0.04/-0	28.0+1.0/-0.0	F	4.88±0.01	124.0±0.25
U	0.30 Min.	7.7 Min.	G	1.18	30.0
V	2.42±0.012	61.5±0.3	H	0.79	20.0
W	0.51±0.008	13.0±0.2	J	0.63	16.0
X	0.65 Min.	16.5 Min.	K	0.71	18.0
Y	0.20±0.006	5.0±0.15	L	1.73	44.0
			M	2.17	55.2
			N	0.47	11.85
			AA	1.38	35.0
			AB	0.45	11.5
			AC	0.55	14.0

32 CM600E2Y-34H

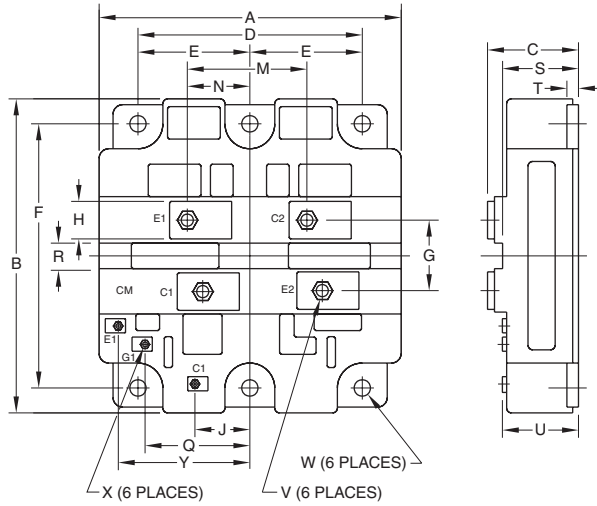

Dim.	Inches	Millimeters	Dim.	Inches	Millimeters
A	5.12	130.0	R	0.20	5.0
B	5.51	140.0	S	1.24	31.5
C	1.50+0.04/-0	38.0+1.0/-0	T	0.20	5.0
D	4.49	114.0	U	1.10+0.04/-0	28.0+1.0/-0
E	2.24±0.01	57.0±0.25	V	M8 Metric	M8
F	4.88±0.01	124.0±0.25	W	0.28 Dia.	7.0 Dia.
G	1.18	30.0	X	M4 Metric	M4
H	0.79	20.0	Y	2.09	53.0
J	0.63	16.0	AA	1.38	35.0
M	2.17	55.2	AB	0.45	11.5
N	0.47	11.85	AC	0.55	14.0
Q	1.58	40.0			

33 CM400HB-90H, CM600HB-90H, CM800HB-66H

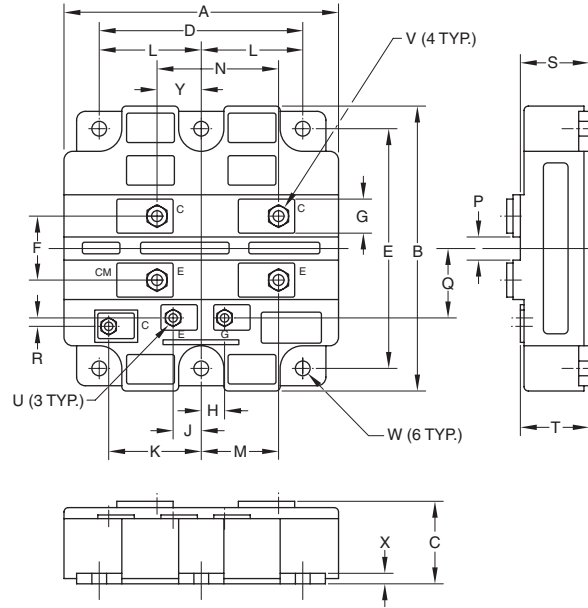

Dim.	Inches	Millimeters	Dim.	Inches	Millimeters
A	5.12	130.0	N	2.42	61.5
B	5.51	140.0	P	0.59	15.0
C	1.50	38.0	Q	1.57	40.0
D	4.48	114.0	R	0.20	5.2
E	4.88±0.01	124.0±0.25	S	1.16	29.5
F	1.57	40.0	T	1.10	28.0
G	0.79	20.0	U	M4 Metric	M4
H	0.41	10.35	V	M8 Metric	M8
J	0.42	10.65	W	0.28 Dia.	7.0 Dia.
K	1.92	48.8	X	0.20	5.0
L	2.24±0.01	57.0±0.25	Y	0.71	18.0
M	1.71	43.5			

34 CM400DY-66H

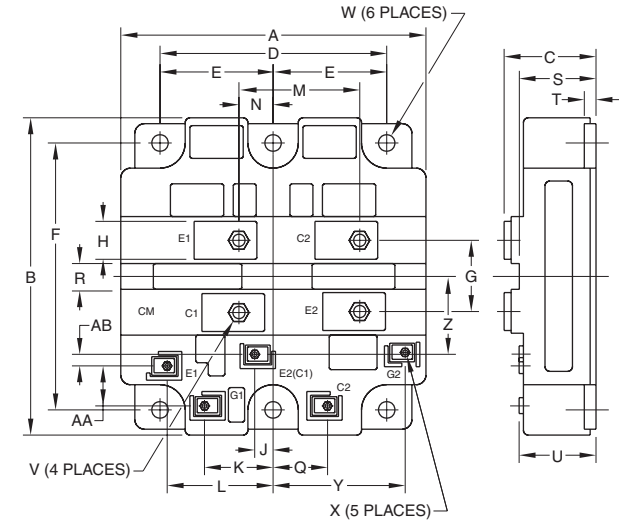

Dim.	Inches	Millimeters	Dim.	Inches	Millimeters
A	5.12	130.0	Q	0.97	24.5
B	5.51	140.0	R	0.59	15.0
C	1.50+0.08/-0	38.0+2.0/-0	S	1.18	30.0
D	4.49	114.0	T	0.20	5.0
E	2.24±0.01	57.0±0.25	U	1.10+0.08/-0	28.0+2.0/-0
F	4.88±0.01	124.0±0.25	V	M8 Metric	M8
G	1.58	40.0	W	0.28 Dia.	7.0 Dia.
H	0.79	20.0	X	M4 Metric	M4
J	0.28	7.2	Y	2.11	53.6
K	1.43	36.3	Z	1.56	39.5
L	1.92	48.8	AA	0.59	15.0
M	2.42	61.5	AB	0.22	5.7
N	0.71	18.0			

35 CM200HG-130H, CM400HG-66H

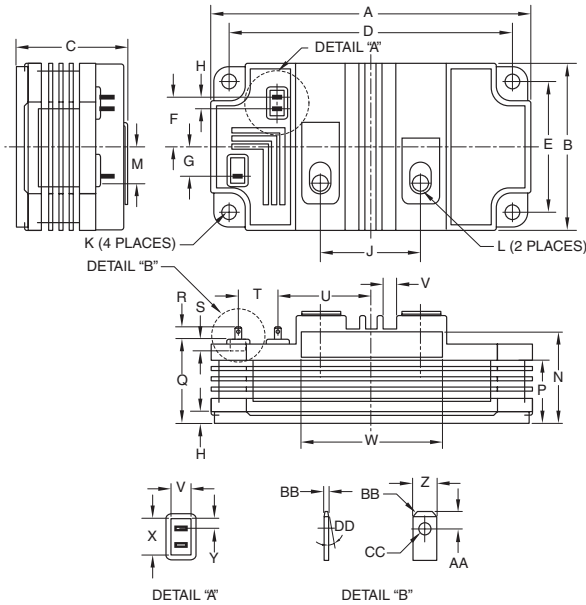

Dim.	Inches	Millimeters
A	5.51	140.0
B	2.87	73.0
C	1.89+0.04/-0.0	48.0+1.0/-0.0
D	4.88	124.0
E	2.24	57.0
F	0.85	21.6
G	0.51	12.9
H	0.20	5.0
J	1.73	44.0
K	M6 Metric	M6
L	M8 Metric	M8
M	0.64	16.2
N	1.59	40.4
P	1.10	28.0

Dim.	Inches	Millimeters
R	0.22	5.5
S	0.16	4.0
T	0.68	17.4
U	1.61	41.0
V	0.24	6.0
W	2.44	62.0
X	0.47	12.0
Y	0.14	3.5
Z	0.11	2.8
AA	0.06	1.6
BB	0.02	0.5
CC	0.05 Dia.	1.2 Dia.
DD	10°	10°

36 CM400E2G-130H, CM400E4G-130H, CM600HG-130H, CM900HG-90H, CM1200HG-66H

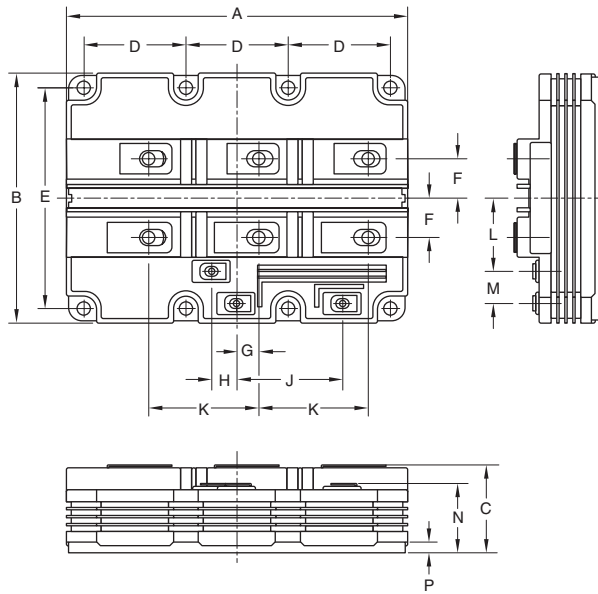

Dim.	Inches	Millimeters
A	7.48	190.0
B	5.51	140.0
C	1.89	48.0
D	2.24	57.0
E	4.88±0.01	124.0±0.25
F	0.87	22.0
G	0.47	12.0

Dim.	Inches	Millimeters
H	0.55	14.0
J	2.33	59.2
K	2.41	61.2
L	1.61	41.0
M	0.71	18.0
N	1.50	38.0
P	0.20	5.0

37 QIC6508001, QID3310005, QID3320002, QID4515001, QID4515002, QID4520002, QID6508001, QIF4515002

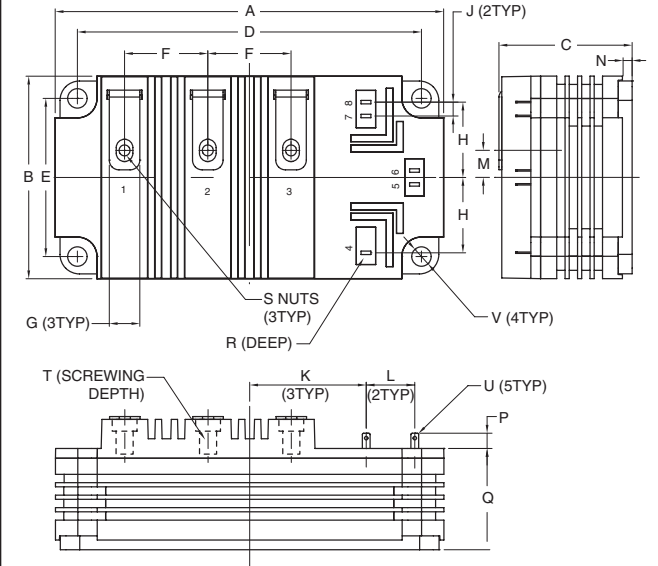

Dim.	Inches	Millimeters
A	5.51	140.0
B	2.87	73.0
C	1.89	48.0
D	4.88±0.01	124.0±0.25
E	2.24±0.01	57.0±0.25
F	1.18	30.0
G	0.43	11.0
H	1.07	27.15
J	0.20	5.0
K	1.65	42.0

Dim.	Inches	Millimeters
L	0.69±0.01	17.5±0.25
M	0.38	9.75
N	0.20	5.0
P	0.22	5.5
Q	1.44	36.5
R	0.16	4.0
S	M6 Metric	M6
T	0.63 Min.	1.6 Min.
U	0.11 x 0.02	2.8 x 0.5
V	0.28 Dia.	7.0 Dia.

38 CM1800DY-34S, CM2500DY-24S

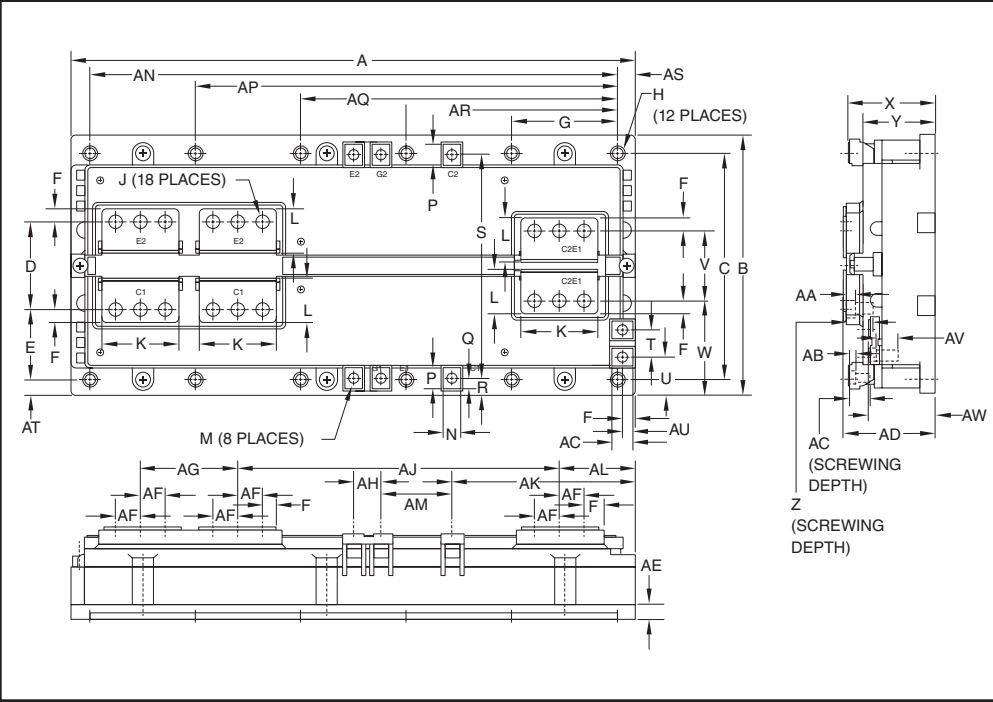

Dim.	Inches	Millimeters
A	12.2	310.0
B	5.6	142.5
C	4.96	126.0
D	1.89	48.0
E	1.85	46.9
F	0.28	7.0
G	2.28	58.0
H	0.21±0.004 Dia.	5.5±0.1 Dia.
J	M6 Metric	M6
K	1.65	42.0
L	0.91	23.0
M	M4 Metric	M4
N	0.35	9.0
P	0.47	11.9
Q	0.21	5.4

Dim.	Inches	Millimeters
R	0.33	8.5
S	4.92	125.0
T	0.6	15.0
U	0.83	21.0
V	1.5	38.0
W	2.04	51.9
X	1.85+0.04/-0.02	47.1+1.0/-0.5
Y	1.55	39.4
Z	0.63	16.0
AA	0.24	6.2
AB	0.16	4.0
AC	0.45	11.5
AD	2.01+0.04/-0.02	51.0+1.0/-0.5
AE	0.32	8.2
AF	0.55	14.0

Dim.	Inches	Millimeters
AG	2.05	52.0
AH	0.59	15.0
AJ	7.01	178.0
AK	3.98	101.0
AL	1.63	41.5
AM	1.54	39.0
AN	11.42	290.0
AP	9.13	232.0
AQ	6.85	174.0
AR	4.56	116.0
AS	0.39	10.0
AT	0.03	8.0
AU	0.02	5.0
AV	0.16	4.0
AW	1.425+0.04/-0.02	36.20+1.0/-0.5

39 CM450DXL-34SA, CM600DXL-24S, CM600DXL-34SA, CM1000DXL-24S

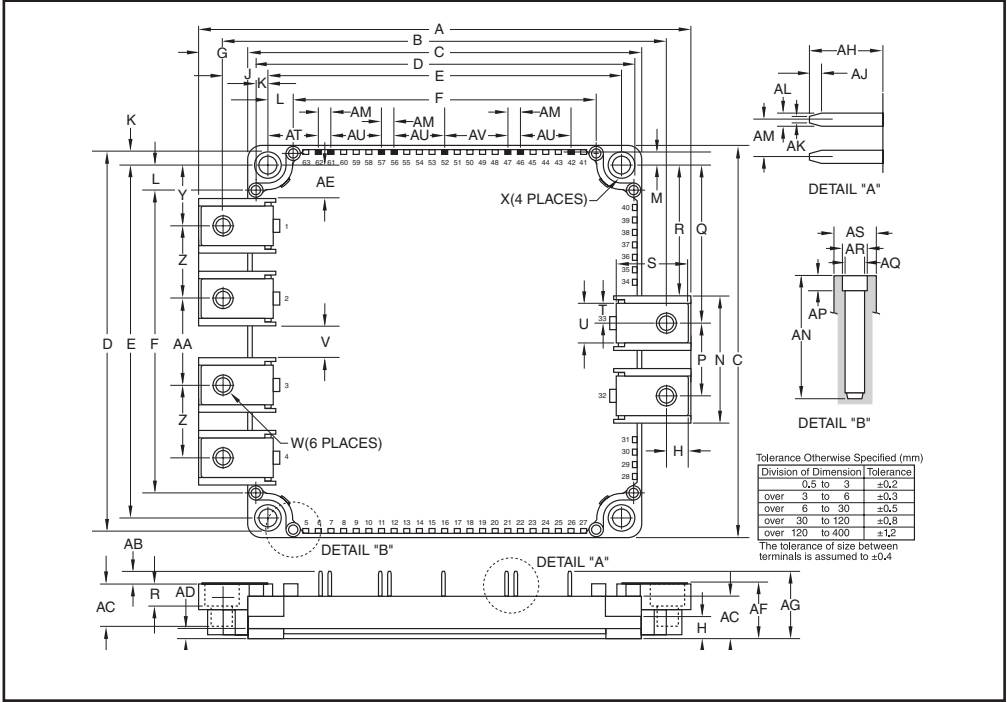

Dim.	Inches	Millimeters
A	5.98	152.0
B	5.39	137.0
C	4.79	121.7
D	4.61	117.2
E	4.33±0.02	110.0±0.5
F	3.72	94.5
G	0.6	15.14
H	0.26	6.5
J	0.53	13.5
K	0.14	3.6
L	0.3	7.75
M	0.016	4.05
N	1.53	39.0
P	0.86	22.0
Q	1.95	49.72

Dim.	Inches	Millimeters
R	1.62	41.22
S	0.83	21.14
T	0.23	6.0
U	0.47	12.0
V	0.41	10.53
W	M6 Metric	M6
X	0.22	5.5 Dia.
Y	0.75	19.24
Z	0.86	22.0
AA	1.08	27.53
AB	0.14	3.5
AC	0.51	13.0
AD	0.19	3.0
AE	0.42	10.74
AF	0.67+0.04/-0.02	17.0+1.0/-0.5

Dim.	Inches	Millimeters
AG	0.81	20.5
AH	0.29	7.4
AJ	0.05	1.2
AK	0.02	0.65
AL	0.04	1.15
AM	0.15	3.81
AN	0.5	12.5
AP	0.12	3.0
AQ	0.088 Dia.	2.25 Dia.
AR	0.102 Dia.	2.6 Dia.
AS	0.16 Dia.	4.3 Dia.
AT	0.67	16.9
AU	0.6	15.24
AV	0.75	19.05

40 CM400HG-130H, CM600HG-90H

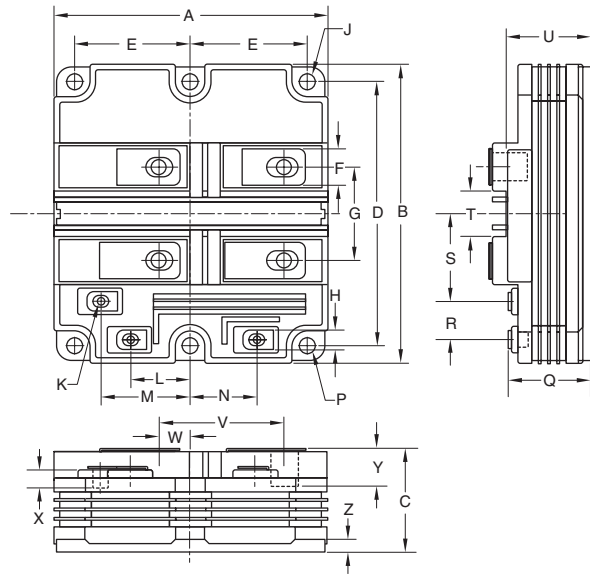

Dim.	Inches	Millimeters	Dim.	Inches	Millimeters
A	5.12±0.02	130.0±0.5	N	1.21±0.02	30.7±0.5
B	5.51±0.02	140.0±0.5	P	0.28 Dia.	7.0 Dia.
C	1.89+0.04/-0.0	48.0+1.0/-0.0	Q	1.5+0.04/-0.0	38.0+1.0/-0.0
D	4.88±0.01	124.0±0.25	R	0.71±0.012	18.0±0.3
E	2.24±0.01	57.0±0.25	S	1.61±0.02	41.0±0.5
F	0.67±0.004	17.0±0.1	T	0.87±0.012	22.0±0.3
G	1.73±0.012	44.0±0.3	U	1.59±0.02	40.4±0.5
H	0.35±0.04	9.0±0.1	V	2.41±0.02	61.2±0.5
J	M8 Metric	M8	W	0.65±0.012	16.5±0.3
K	M4 Metric	M4	X	0.30 Min.	7.7 Min.
L	1.12±0.02	28.5±0.5	Y	0.65 Min.	16.5 Min.
M	1.67±0.02	42.5±0.5	Z	0.2±0.006	5.0±0.15

41 CM800HC-66H, CM1000HC-66R

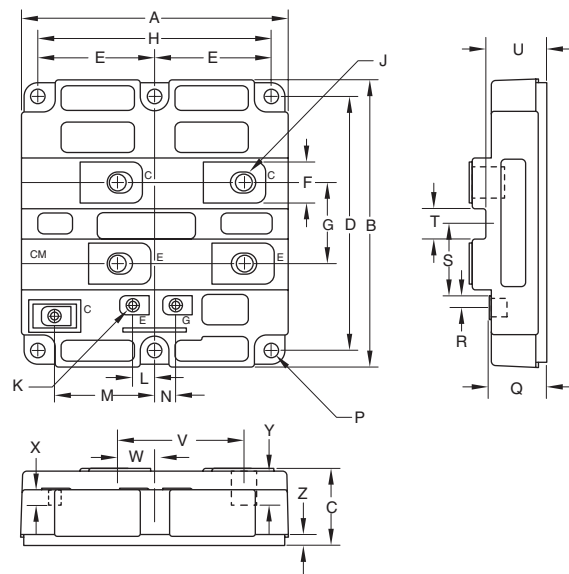

Dim.	Inches	Millimeters	Dim.	Inches	Millimeters
A	5.12±0.02	130.0±0.5	N	0.41±0.008	10.35±0.2
B	5.51±0.02	140.0±0.5	P	0.28 Dia.	7.0 Dia.
C	1.5+0.04/-0.0	38.0+1.0/-0.0	Q	1.10+0.04/-0.0	28.0+1.0/-0.0
D	4.88±0.004	124.0±0.1	R	0.20±0.008	5.2±0.2
E	2.24±0.004	57.0±0.1	S	1.57±0.012	40.0±0.3
F	0.79+0.04/-0.008	20.0+0.1/-0.2	T	0.59±0.008	15.0±0.2
G	1.57±0.008	40.0±0.2	U	1.16±0.02	29.5±0.5
H	4.49±0.004	114.0±0.1	V	2.42±0.012	61.5±0.3
J	M8 Metric	M8	W	0.71±0.008	18.0±0.2
K	M4 Metric	M4	X	0.30 Min.	7.7 Min.
L	0.42±0.008	10.65±0.2	Y	0.65 Min.	16.5 Min.
M	1.92±0.012	48.8±0.3	Z	0.20±0.006	5.0±0.15

42 CM150RXL-34SA

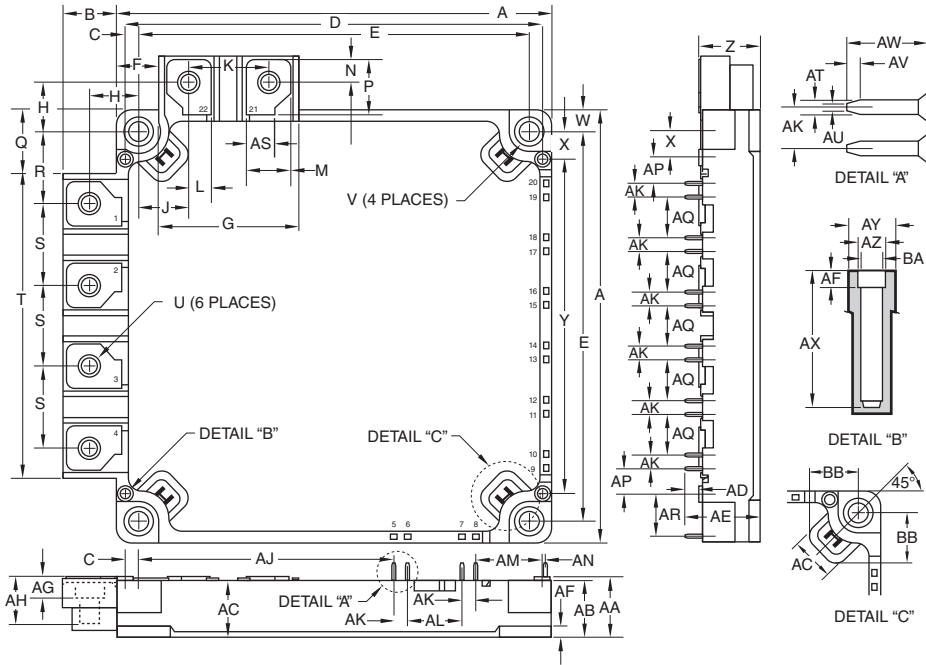

Dim.	Inches	Millimeters	Dim.	Inches	Millimeters	Dim.	Inches	Millimeters
A	4.79	121.7	T	3.37	85.58	AL	0.60	15.24
B	0.59	15.1	U	M5 Metric	M5	AM	0.75	19.23
C	0.14	3.6	V	0.22 Dia.	5.5 Dia.	AN	0.017	0.45
D	4.61	117.2	W	0.23	5.86	AP	0.28	7.24
E	4.33±0.02	110.0±0.5	X	0.30	7.75	AQ	0.43	11.42
F	0.45	11.5	Y	3.72	94.5	AR	0.43	11.08
G	1.53	39.0	Z	0.67+0.04/-0.02	17.0 +1/-0.5	AS	0.31	8.0
H	0.53	13.5	AA	0.67	17.0	AT	0.04	1.15
J	0.55	14.14	AB	0.63	16.0	AU	0.02	0.65
K	0.87	22.0	AC	0.51	13.0	AV	0.05	1.2
L	0.24	6.0	AD	0.14	3.5	AW	0.18	4.5
M	0.47	12.0	AE	0.81	20.5	AX	0.49	12.5
N	0.37	6.5	AF	0.12	3.0	AY	0.18 Dia.	4.5 Dia.
P	0.61	15.64	AG	0.23	5.9	AZ	0.102 Dia.	2.6 Dia.
Q	0.71	18.06	AH	0.53	13.4	BA	0.088 Dia.	2.25 Dia.
R	0.81	20.71	AJ	2.81	71.52	BB	0.54	13.7
S	0.9	22.86	AK	0.15	3.81			

43 CM150EXS-24S, CM200EXS-24S, CM200EXS-34SA, CM300EXS-24S

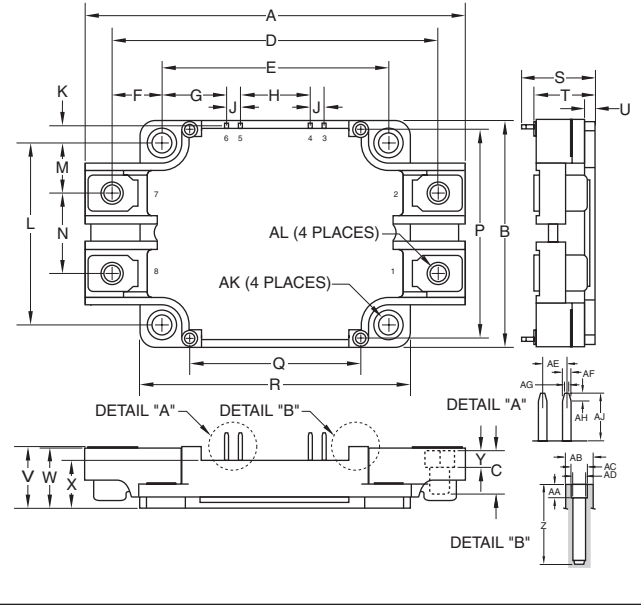

Dim.	Inches	Millimeters	Dim.	Inches	Millimeters
A	4.09	104.0	U	0.27	7.0
B	2.44	62.0	V	0.67	17.0
C	0.47	11.9	W	0.64	16.4
D	3.5	89.0	X	0.51	13.1
E	2.44	62.0	Y	0.17	4.4
F	0.53	13.5	Z	0.49	12.5
G	0.69	17.66	AA	0.12	3.0
H	0.75	19.05	AB	0.17 Dia.	4.3 Dia.
J	0.14	3.8	AC	0.102 Dia.	2.6 Dia.
K	0.16	4.2	AD	0.088 Dia.	2.25 Dia.
L	1.97	50.0	AE	0.15	3.81
M	0.55	14.0	AF	0.045	1.15
N	0.87	22.0	AG	0.025	0.65
P	2.26	57.5	AH	0.05	1.2
Q	1.83	46.5	AJ	0.29	7.4
R	2.9	73.71	AK	0.21 Dia.	5.5 Dia.
S	0.8	20.5	AL	M5 Metric	M5
T	0.67	17.0			

44 CM150DX-34SA, CM200DX-34SA,
CM300DX-34SA, CM450DX-34SA

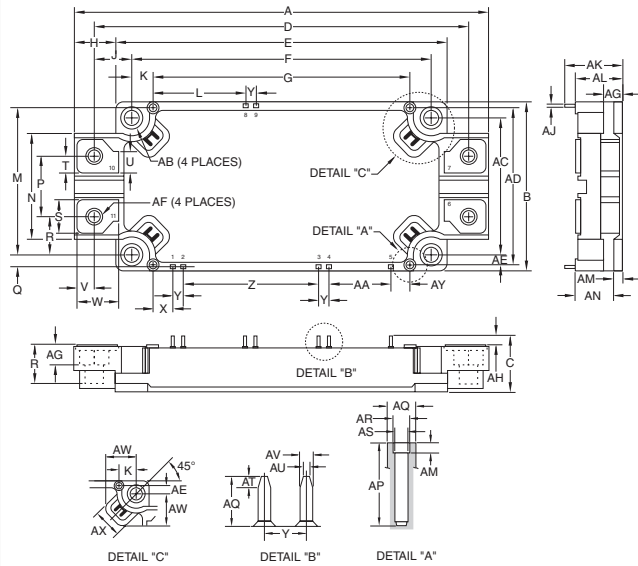

Dim.	Inches	Millimeters	Dim.	Inches	Millimeters
A	5.98	152.0	AA	0.9	22.86
B	2.44	62.0	AB	0.22 Dia.	5.5 Dia.
C	0.67+0.04/-0.02	17.0+1.0/-0.5	AC	1.97±0.02	50.0±0.5
D	5.39	137.0	AD	2.26	57.5
E	4.79	121.7	AE	0.15	3.75
F	4.33±0.02	110.0±0.5	AF	M6	M6
G	3.72	94.5	AG	0.28	7.0
H	0.60	15.14	AH	0.14	3.5
J	0.53	13.5	AJ	0.03	0.8
K	0.31	7.75	AK	0.81	20.5
L	1.33±0.012	33.91±0.3	AL	0.70	17.0
M	2.13	54.2	AM	0.12	3.0
N	1.54	39.0	AN	0.65	16.5
P	0.87	22.0	AP	0.49	12.5
Q	0.17	4.2	AQ	0.18	4.5
R	0.55	14.0	AR	0.102 Dia.	2.6 Dia.
S	0.47	12.0	AS	0.089 Dia.	2.25 Dia.
T	0.24	6.0	AT	0.05	1.2
U	0.31	8.0	AU	0.03	0.65
V	0.26	6.5	AV	0.05	1.15
W	0.62	15.64	AW	0.54	13.7
X	0.28±0.012	7.24±0.3	AX	0.52	13.0
Y	0.15	3.81	AY	0.285	7.25
Z	1.95	49.5			

45 CM800HG-90R

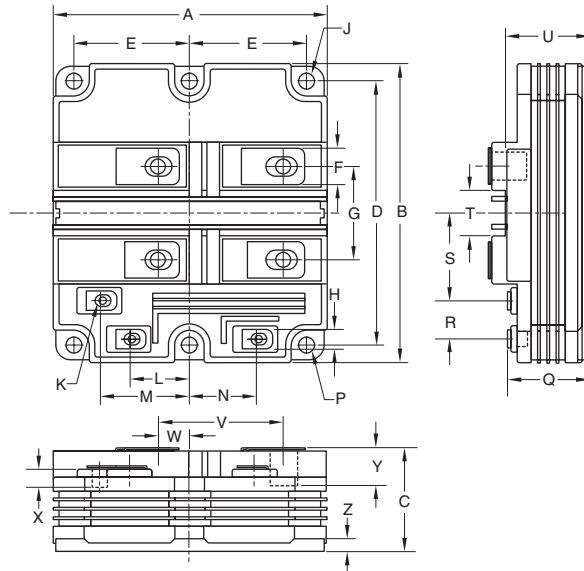

Dim.	Inches	Millimeters	Dim.	Inches	Millimeters
A	5.12±0.02	130.0±0.5	N	1.21±0.02	30.7±0.5
B	5.51±0.02	140.0±0.5	P	0.28 Dia.	7.0 Dia.
C	1.89+0.04/-0.0	48.0+1.0/-0.0	Q	1.5+0.04/-0.0	38.0+1.0/-0.0
D	4.88±0.01	124.0±0.25	R	0.71±0.012	18.0±0.3
E	2.24±0.01	57.0±0.25	S	1.61±0.02	41.0±0.5
F	0.67±0.004	17.0±0.1	T	0.87±0.012	22.0±0.3
G	1.73±0.012	44.0±0.3	U	1.59±0.02	40.4±0.5
H	0.35±0.04	9.0±0.1	V	2.41±0.02	61.2±0.5
J	M8 Metric	M8	W	0.65±0.012	16.5±0.3
K	M4 Metric	M4	X	0.30 Min.	7.7 Min.
L	1.12±0.02	28.5±0.5	Y	0.65 Min.	16.5 Min.
M	1.67±0.02	42.5±0.5	Z	0.2±0.006	5.0±0.15

46 QIS2510001, QIS4506001

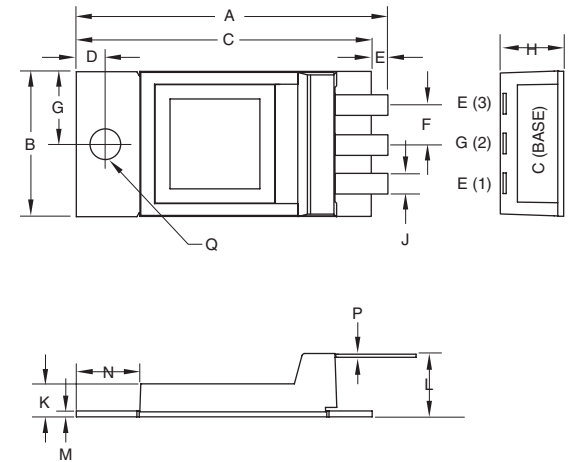

Dim.	Inches	Millimeters	Dim.	Inches	Millimeters
A	2.31	53.6	J	0.14	3.6
B	0.98	25.0	K	0.22	5.7
C	2.01	51.0	L	0.43	10.8
D	0.2	5.0	M	0.04	1.0
E	0.1	2.5	N	0.43	10.9
F	0.27	6.9	P	0.02	0.5
G	0.49	12.5	Q	0.21 Dia.	5.3 Dia.
H	0.46 Max.	11.8 Max.			

47 QIS4506002, QIS6502002

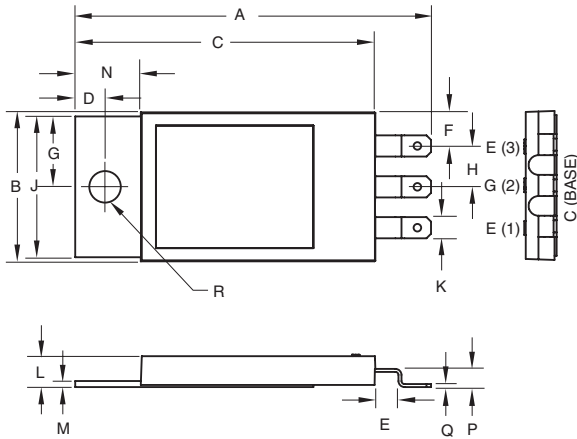

Dim.	Inches	Millimeters	Dim.	Inches	Millimeters
A	2.35	59.7	J	0.93	23.6
B	0.98	25.0	K	0.14	3.6
C	1.98	50.3	L	0.20	5.2
D	0.197	5.0	M	0.40	1.0
E	0.22	5.5	N	0.43	11.0
F	0.22	5.6	P	0.20	0.5
G	0.465	11.8	Q	0.12	3.0
H	0.27	6.9	R	0.208 Dia.	5.3 Dia.

48 QID0660023

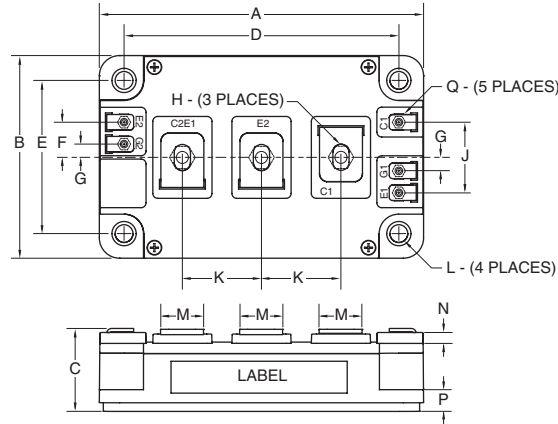

Dim.	Inches	Millimeters	Dim.	Inches	Millimeters
A	4.00	101.6	J	0.87	22.1
B	2.50	63.5	K	0.98	24.9
C	1.00±0.015	25.4±0.4	L	0.22 Dia.	5.6 Dia.
D	3.39	86.1	M	0.53	13.5
E	1.89	48.0	N	0.09 Min.	2.3 Min.
F	0.435	11.0	P	0.27	6.9
G	0.165	4.2	Q	#2-56 X 0.17 Min.	
H		#10-32 X 0.31 Min.			

49 QIQ0645001

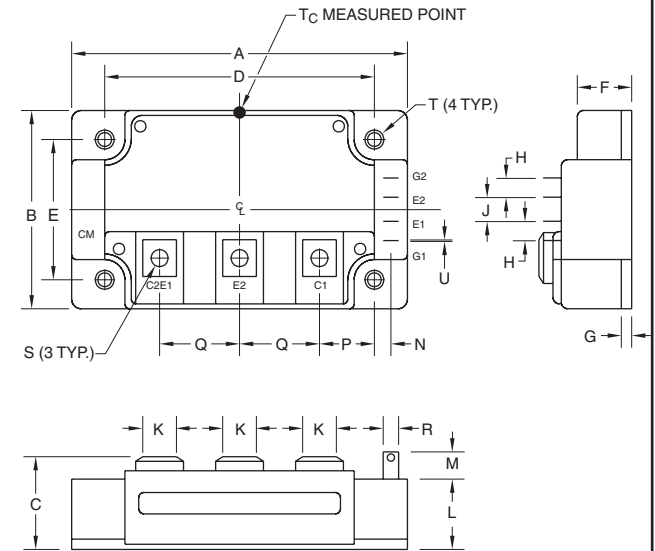

Dim.	Inches	Millimeters	Dim.	Inches	Millimeters
A	4.25	108.0	K	0.55	14.0
B	2.44	62.0	L	0.87	22.0
C	1.14+0.04/-0.02	29.0+1.0/-0.5	M	0.33	8.5
D	3.66±0.01	93.0±0.25	N	0.10	2.5
E	1.88±0.01	48.0±0.25	P	0.85	21.5
F	0.67	17.0	Q	0.98	25.0
G	0.16	4.0	R	0.11	2.8
H	0.24	6.0	S	M6 Metric	M6
J	0.59	15.0	T	0.25 Dia.	6.5 Dia.

50 CM225DX-24S1, CM300DX-24S1, CM450DX-24S1, CM600DX-24S1

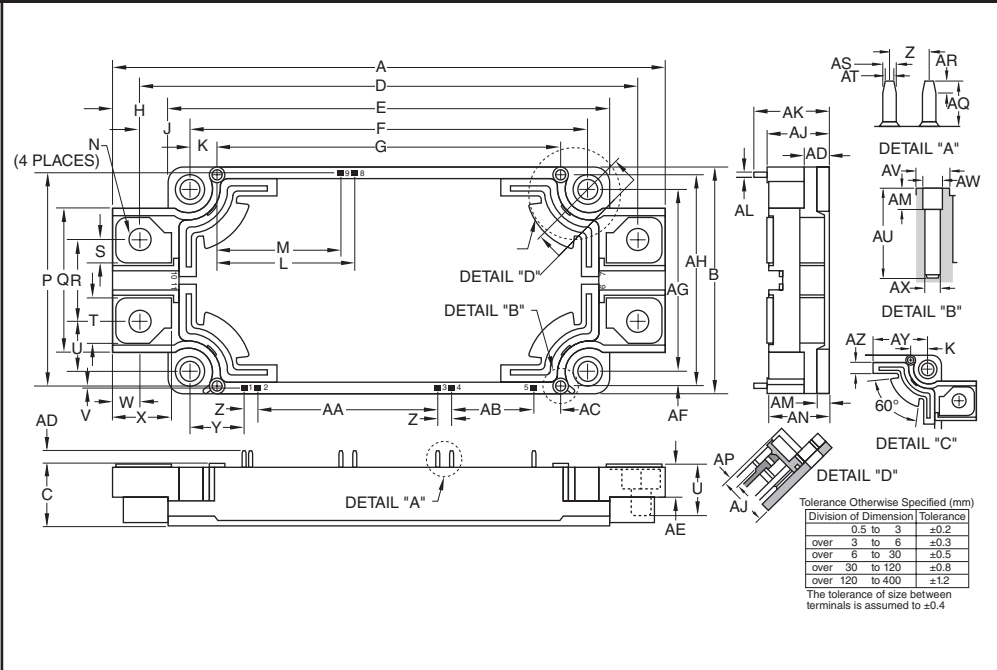

Dim.	Inches	Millimeters	Dim.	Inches	Millimeters	Dim.	Inches	Millimeters
A	5.98	152.0	S	0.23	6.0	AJ	0.67	17.0
B	2.44	62.0	T	0.47	12.0	AK	0.81	20.5
C	0.67+0.04/-0.02	17.0+1/-0.5	U	0.55	14.0	AL	0.03	0.8
D	5.39	137.0	V	0.04±0.019	0.95±0.3	AM	0.12	3.0
E	4.79	121.7	W	2.56	65.0	AN	0.65	16.5
F	4.33±0.02	110±0.5	X	0.61	15.64	AP	0.13	3.4
G	3.72	94.5	Y	0.284±0.019	7.24±0.3	AQ	0.17	4.5
H	0.60	15.14	Z	0.15±0.019	3.81±0.3	AR	0.05	1.2
J	0.53	13.5	AA	1.95±0.019	49.53±0.3	AS	0.05	1.15
K	0.30	7.75	AB	0.9±0.019	22.86±0.3	AT	0.025	0.65
L	1.48±0.019	37.72±0.3	AC	0.285±0.019	7.25±0.3	AU	0.49	12.5
M	1.33±0.019	33.91±0.3	AD	0.14	3.5	AV	0.17 Dia.	4.5 Dia.
N	M6 Metric	M6	AE	0.27	7.0	AW	0.102 Dia.	2.6 Dia.
P	2.28±0.019	57.95±0.3	AF	0.15	3.75	AX	0.088 Dia.	2.25 Dia.
Q	1.53	39.0	AG	1.97±0.02	50.0±0.5	AY	0.95	24.2
R	0.86	22.0	AH	2.26	57.5	AZ	0.19	5.0

51 QID3320004, QID4515004

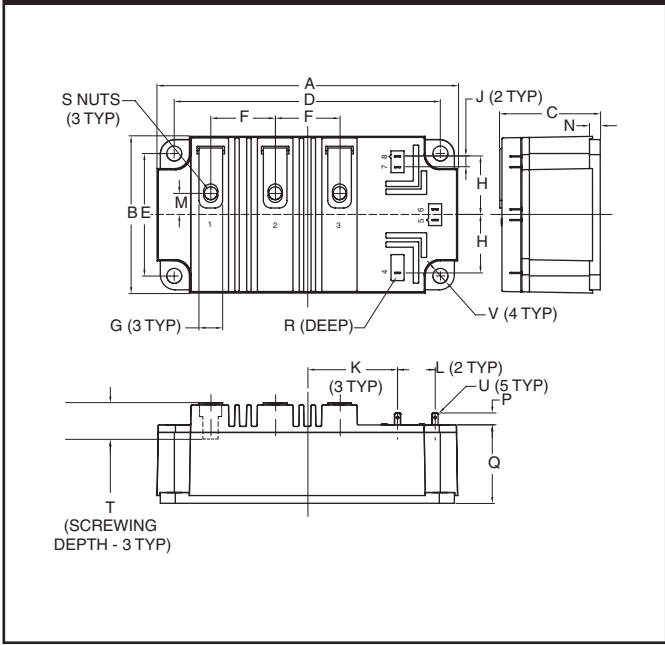

Dim.	Inches	Millimeters	Dim.	Inches	Millimeters
A	5.51	140.0	L	0.69±0.01	17.5±0.25
B	2.87	73.0	M	0.38	9.75
C	1.50	38.0	N	0.20	5.0
D	4.88±0.01	124.0±0.25	P	0.22	5.5
E	2.24±0.01	57.0±0.25	Q	1.04	26.5
F	1.18	30.0	R	0.16	4.0
G	0.43	11.0	S	M5 Metric	M5
H	1.07	27.15	T	0.63 Min.	16.0 Min.
J	0.20	5.0	U	0.11 x 0.02	2.8 x 0.5
K	1.65	42.0	V	0.28 Dia.	7.0 Dia.

52 CM100TX-24S1, CM150TX-24S1

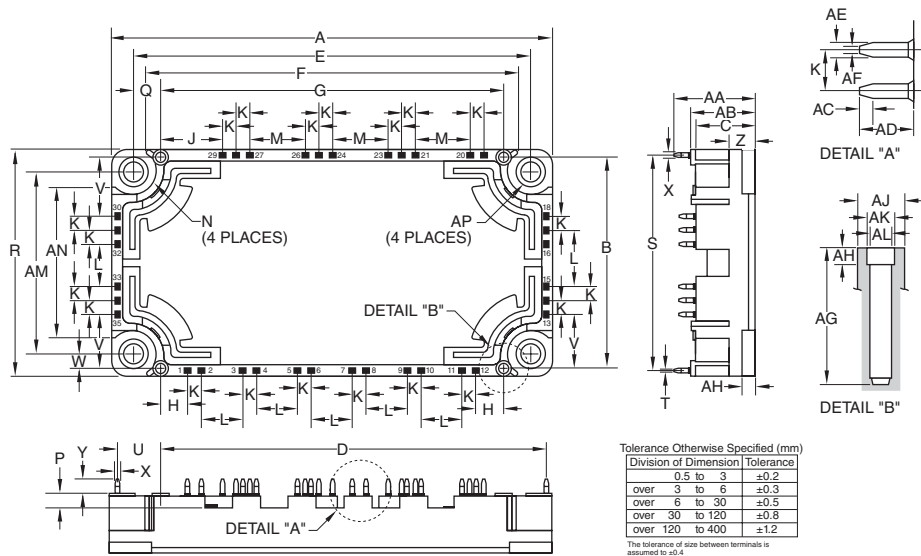

Dim.	Inches	Millimeters
A	4.79	121.7
B	2.26	57.5
C	0.63	16.0
D	4.18±0.008	106.31±0.2
E	4.33±0.02	110.0±0.5
F	4.027	102.3
G	3.72	94.5
H	0.28	7.24
J	0.66±0.019	16.77±0.3
K	0.15	3.81
L	0.45	11.42
M	0.6	15.24
N	0.26 Rad.	6.5 Rad.

Dim.	Inches	Millimeters
P	0.16	4.0
Q	0.29	7.75
R	2.44	62.0
S	2.28±0.008	57.95±0.2
T	0.17±0.008	0.45±0.2
U	0.46±0.008	11.8±0.2
V	0.60	15.41
W	0.15	3.75
X	0.03	0.8
Y	0.14	3.5
Z	0.27	7.0
AA	0.81	20.5
AB	0.67	17.0

Dim.	Inches	Millimeters
AC	0.05	1.2
AD	0.18	4.5
AE	0.05	1.15
AF	0.02	0.65
AG	0.49	12.5
AH	0.12	3.0
AJ	0.18 Dia.	4.5 Dia.
AK	0.102 Dia.	2.6 Dia.
AL	0.088 Dia.	2.25 Dia.
AM	1.97±0.0	50.0±0.5
AN	1.65	41.9
AP	0.22 Dia.	5.5 Dia.

53 CM100RX-24S1, CM150RX-24S1

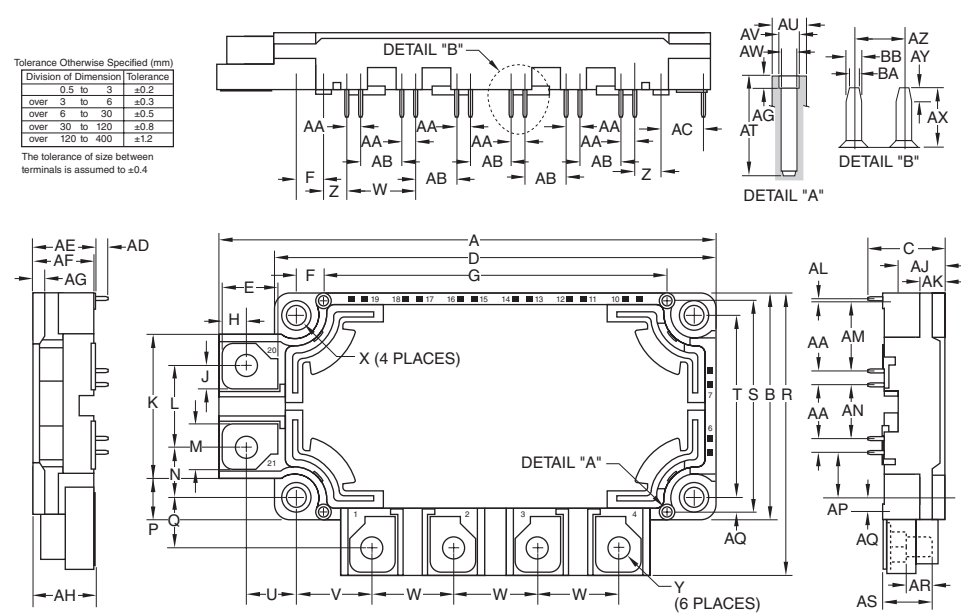

Dim.	Inches	Millimeters
A	5.39	136.9
B	2.44	62.0
C	0.81	20.5
D	4.79	121.7
E	0.61	15.64
F	0.30	7.75
G	3.72	94.5
H	0.26	6.5
J	0.24	6.0
K	1.53	39.0
L	.87	22.0
M	0.48	12.0
N	0.55	14.0
P	0.45	11.5
Q	0.54	13.64
R	3.03	77.1
S	2.26	57.5

Dim.	Inches	Millimeters
T	1.97±0.02	50.0±0.5
U	0.53	13.5
V	0.81	20.71
W	0.9	22.86
X	0.22 Dia.	5.5 Dia.
Z	0.28	7.24
AA	0.15	3.82
AB	0.45	11.42
AC	0.46±0.008	11.8±0.2
AD	0.14	3.5
AE	0.67	17.0
AF	0.65	16.5
AG	0.12	3.0
AH	0.67+0.04/-0.0	17.0+1.0/-0.5
AJ	0.53	13.6
AK	0.27	7.0

Dim.	Inches	Millimeters
AL	0.02	0.55
AM	0.75	19.12
AN	0.6	15.24
AP	0.46	11.67
AQ	0.15	3.75
AR	0.23	5.9
AS	0.53	13.4
AT	0.49	12.5
AU	0.18 Dia.	4.5 Dia.
AV	0.102 Dia.	2.6 Dia.
AW	0.088 Dia.	2.25 Dia.
AX	0.18	4.5
AY	0.05	1.2
AZ	0.15	3.81
BA	0.02	0.65
BB	0.05	1.15

56 QIS176002, QIS1790001

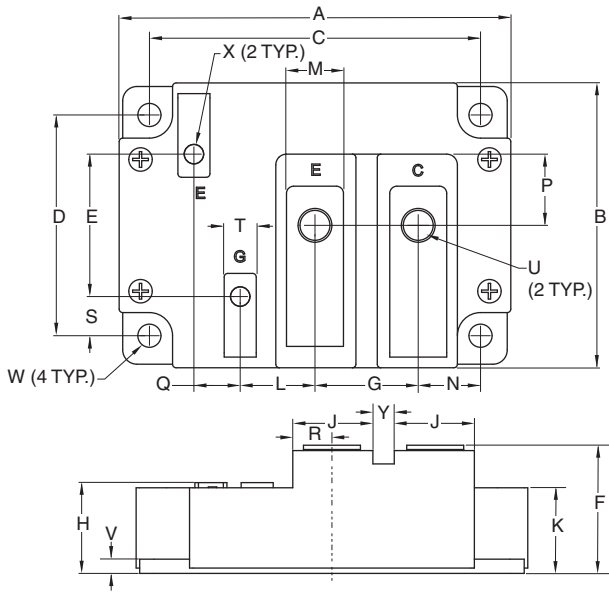

Dim.	Inches	Millimeters
A	4.33	110.0
B	3.15	80.0
C	3.66±0.008	93.0±0.25
D	2.44±0.008	62.0±0.25
E	1.57	40.0
F	1.42 Max.	36.0 Max.
G	1.14	29.0
H	1.00 Max.	25.5 Max.
J	0.89	22.5
K	0.93	23.5
L	0.83	21.0
M	0.63	16.0

Dim.	Inches	Millimeters
N	0.69	17.5
P	0.79	20.0
Q	0.51	13.0
R	0.43	11.0
S	0.43	11.0
T	0.35	9.0
U	M8 Metric	M8
V	0.16	4.0
W	0.256 Dia.	6.5 Dia.
X	M4 Metric	M4
Y	0.24	6.0

57 QID3340001, QID3350001

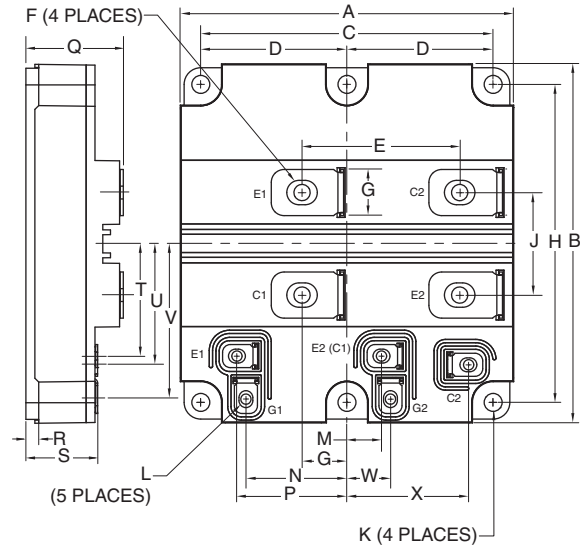

Dim.	Inches	Millimeters
A	5.11	130.0
B	5.51	140.0
C	4.49	114.0
D	2.24	57.0
E	2.42	61.5
F	M8	M8 Metric
G	0.71	18.0
H	4.88	124.0
J	1.57	40.0
K	0.27	7.0 Dia.
L	M4	M4 Metric

Dim.	Inches	Millimeters
M	0.51	13.0
N	1.57	39.9
P	1.71	43.4
Q	1.49	38.0
R	0.20	5.0
S	1.10	28.0
T	1.72	43.8
U	1.86	47.2
V	2.39	60.6
W	0.65	16.5
X	1.85	47.0

HYBRID & SiC MODULES

Hybrid Si / SiC IGBT Modules

Combining the industry's fastest power IGBT of the Powerex NFH-Series with a Zero Recovery® Schottky diode, Powerex hybrid split dual Si / SiC IGBT modules are designed for use in high frequency applications; upwards of 30kHz for hard switching applications and 60 to 80 kHz for soft switching applications.

Applications Include:

- Energy Saving Power Systems (fans, pumps and consumer appliances)
- High Frequency Type Power Systems (UPS, high speed motor drives, induction heating, welder and robotics)
- High Temperature Power Systems (power electronics in electric vehicle and aviation systems)

SiC MOSFET Modules

Powerex also offers SiC (silicon carbide) MOSFET (Metal Oxide Semiconductor Field Effect Transistor) modules.

SiC Schottky Diode Modules

Powerex also offers SiC (silicon carbide) Schottky diode modules.

Applications:

- High Efficiency Inverters
- High Frequency Power Supplies
- High Temperature Environment

Circuit Configurations:

- Single
- Dual
- In-Parallel
- Common Collector (Drain)
- Common Emitter (Source)

TABLE OF CONTENTS

Split Dual Si / SiC Hybrid IGBT Modules	B-2
Split Dual SiC Super Fast Diode Modules ..	B-3
SiC & Si MOSFET Modules	B-4
Outline Drawings	B-5

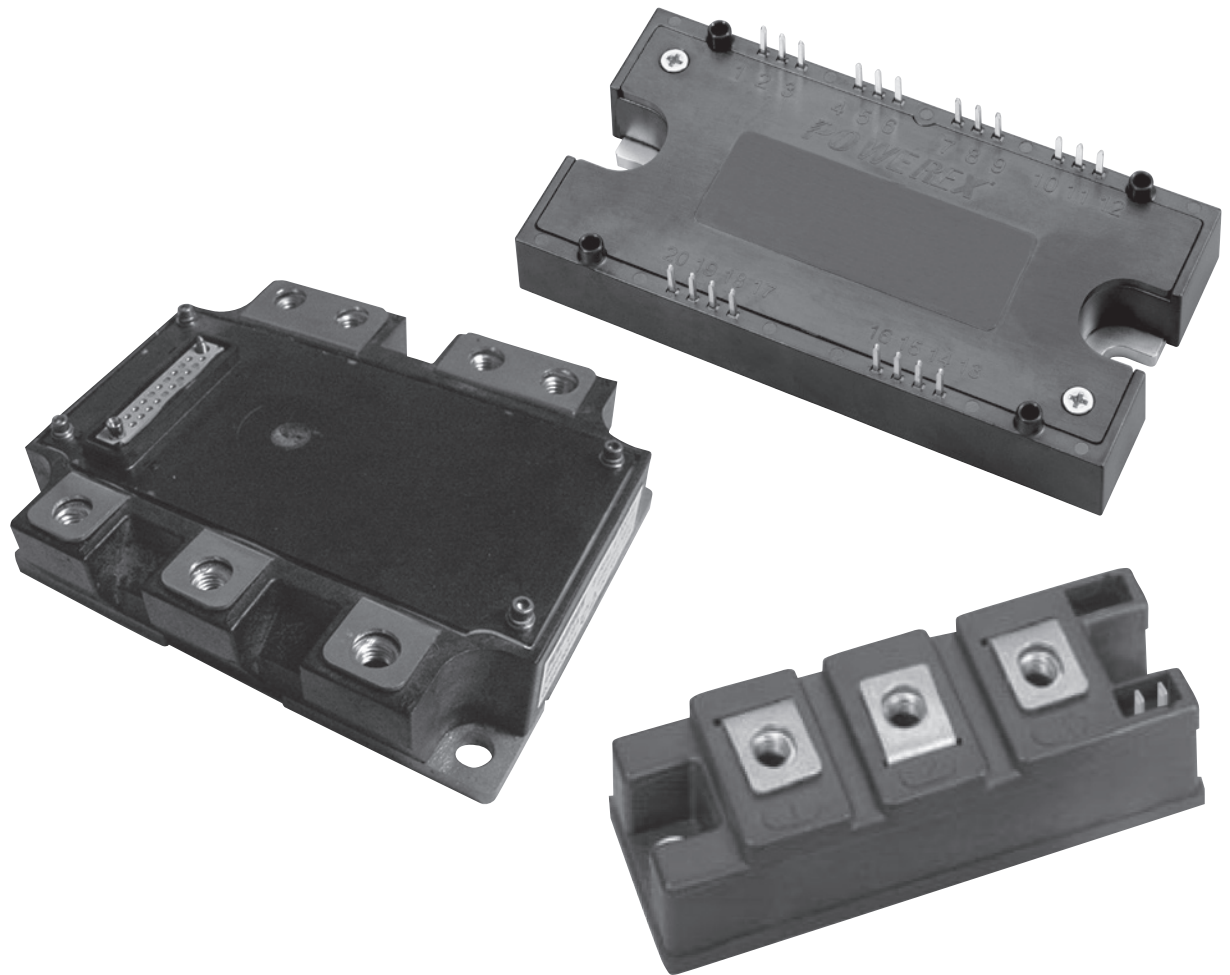

VOLTAGE: 100V TO 1200V
CURRENT: 100A TO 300A

Split Dual Si / SiC Hybrid IGBT Modules,

(Refer to device datasheets at www.pwr.com for test conditions.)

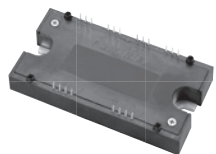

QID1210005, QID1210007,
QID1210006, QID1215003

MAXIMUM RATINGS						ELECTRICAL CHARACTERISTICS										
Type	V_{CES} Volts	I_C Amperes	I_{CM} Amperes	$T_{j(MAX)}$ °C	V_{RMS} Isolation Volts	Static Test Conditions		$T_j = 25^\circ\text{C}$		Dynamic						
						I_C Amperes	V_{GE} Volts	Typ.	Max.	$V_{GE} = 0V, V_{CE} = 10V, f = 1\text{kHz}$			Resistive Load Switching Times			
								$V_{CES(SAT)}$ Volts	$V_{CES(SAT)}$ Volts	C_{ies} nF	C_{oes} nF	C_{res} nF	$t_{d(on)}$ ns	t_r ns	$t_{d(off)}$ ns	t_r ns
QID1210005	1200	100	200	150	2500	100	15	5.0	6.5	16	1.3	0.3	TBD	TBD	TBD	TBD
QID1210006	1200	100	200	150	2500	100	15	5.0	6.5	16	1.3	0.3	TBD	TBD	TBD	TBD
QID1210007	1200	100	200	150	2500	100	15	5.0	6.5	16	1.3	0.3	TBD	TBD	TBD	TBD
QID1215003	1200	100	300	150	2500	150	15	5.0	6.5	24	2.0	0.45	TBD	TBD	TBD	TBD

Type	FREE WHEEL DIODE			THERMAL CHARACTERISTICS			Interface Per Module (Typ.)	Weight Grams	Outline Drawings	
	I_{FM} Amperes	V_{FM} Volts	t_{rr} ns	IGBT (Max.) $R_{th(j-c)}$ °C/W	Diode (Max.) $R_{th(j-c)}$ °C/W	$R_{th(c-f)}$ °C/W			Number	Page
QID1210005	80	2.0	—	0.17	0.304	0.04	270	1	B-5	
QID1210006	80	2.0	—	0.21	0.39	0.04	130	1	B-5	
QID1210007	75	1.75	—	0.17	0.5	0.04	270	1	B-5	
QID1215003	150	1.75	—	0.13	0.25	0.04	270	1	B-5	

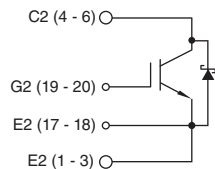
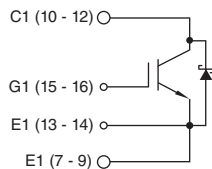

Numbering System

QID1210005 is a 1200V, 100A
Split Dual Si / SiC Hybrid IGBT Module

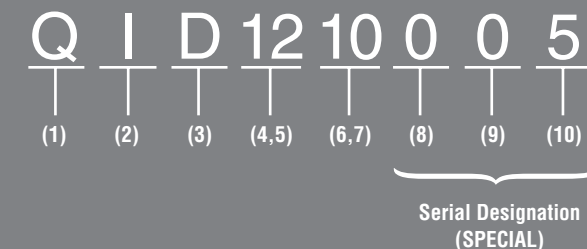

(1) Product Line

(2) Device:
I = IGBT

(3) Configuration:
D = Double / Dual

(4,5) Voltage:
12 = 1200

(6,7) Current:
10 = 100

Serial Designation

SPECIAL:

(8) 0 – 9 (Numbered from 001 – 999 for
(9) 0 – 9 each individual combination of
(10) 0 – 9 7 previous digits.)

Split Dual SiC Super Fast Diode Modules,

(Refer to device datasheets at www.pwr.com for test conditions.)

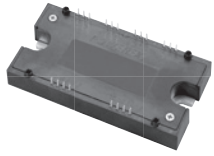

QRD1210004,
QRD1210005

MAXIMUM RATINGS							ELECTRICAL AND THERMAL CHARACTERISTICS					
Type	V _{RRM} Volts	I _{F(DC)} Amperes	I _{FSM} Amperes	T _{j(MAX)} °C	V _{RMS} Isolation Volts	i ² t A ² sec (8.3ms, T _{j(max)} , 100% V _{RRM} Reapplied)	V _{FM} /I _F Volts/Amperes (T _j = 175°C)	R _{th(j-c)} °C/W	R _{th(c-s)} °C/W	Weight Grams	Outline Drawings Number Page	
QRD1210004	1200	100	TBD	175	2500	TBD	3.0 / 100	0.26	0.04	270	3	B-5
QRD1210005	1200	100	TBD	175	2500	TBD	3.0 / 100	0.26	0.04	140	3	B-5

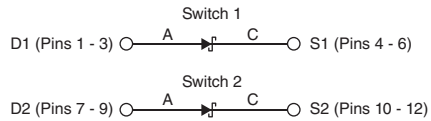

Numbering System

QRD1210005 is a 1200V, 100A
Split Dual SiC Super Fast Diode Module

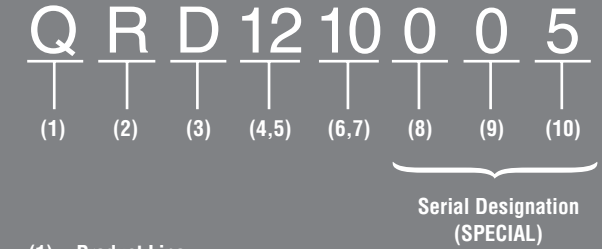

(1) Product Line

(2) Device:
R = Rectifier

(3) Configuration:
D = Double / Dual

(4,5) Voltage:
12 = 1200

(6,7) Current:
10 = 100

Serial Designation

SPECIAL:

(8) 0 – 9 (Numbered from 001 – 999 for
(9) 0 – 9 each individual combination of
(10) 0 – 9 7 previous digits.)

SiC and Si MOSFET Modules, (Refer to device datasheets at www.pwr.com for test conditions.)



QJS0512001

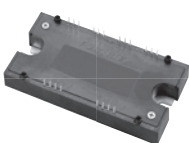

QJD1210010,
QJD1210011,
QJD1210SA1,
QJD1210SA2



QJE0130018,
QJE0130021

MAXIMUM RATINGS					ELECTRICAL CHARACTERISTICS					THERMAL CHARACTERISTICS			Weight Grams	Outline Drawings	
Type	V _{DS} Volts	I _D Amperes T _J = 25°C (Typ.)	T _{J(MAX)} °C	V _{RMS} Isolation Volts	Static					MOSFET (Typ.)	Module (Max.)	Number		Page	
					R _{DS(on)} (mΩ) (Typ.)	V _{DSS} Volts (Min.)	I _{DSS} (μA) (Max.)	V _{SD} Volts (Max.)	Q _C (nC) (Typ.)	R _{th(j-c)} °C/W	R _{th(c-f)} °C/W				
Single Si MOSFET Module															
QJS0512001	500	120	150	2500	22	500	20	1.5	380	0.1	0.075	220	4	B-6	

MAXIMUM RATINGS						ELECTRICAL CHARACTERISTICS					THERMAL CHARACTERISTICS			Weight Grams	Outline Drawings	
Type	V _{DSS} Volts	I _D Amperes	I _{D(1)} Amperes	P _d Watts	V _{RMS} Isolation Volts	V _{GS} = 0V					Interface Per Module (Typ.)	MOSFET (Max.)	Diode (Max.)		Number	Page
						R _{DS(on)} mΩ	V _{SD} Volts	C _{iss} nF	C _{rss} nF	Q _G nC	R _{th(c-s)} °C/W	R _{th(j-c)} °C/W	R _{th(j-c)} °C/W			
Split Dual SiC 1200V Modules																
QJD1210010	1200	100*	250	1080	3000	15	4.0	10.2	0.1	550	0.04	0.138	0.243	270	2	B-5
QJD1210011	1200	100*	250	900	3000	15	4.0	10.2	0.1	550	0.04	0.167	0.294	140	2	B-5
QJD1210SA1	1200	100*	200	520	3000	18	1.45	8.2	0.1	300	0.04	0.24	0.39	270	2	B-5
QJD1210SA2	1200	100*	200	415	3000	17	1.45	8.2	0.1	300	0.04	0.29	0.47	140	2	B-5
6-Pack SiC High Power Modules																
QJE0130018	100	300	—	960	2500	1.8	1.3	110	15	1800	0.1	0.13	—	430	5	B-6
QJE0130021	100	300	—	960	2500	1.8	1.3	110	15	1800	—	0.13	—	430	5	B-6

* Current rating when wired as a Dual

Single MOSFET Module

QJS0512001

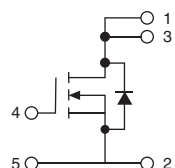

Split Dual MOSFET Module

QJD1210010, QJD1210011, QJD1210SA1, QJD1210SA2

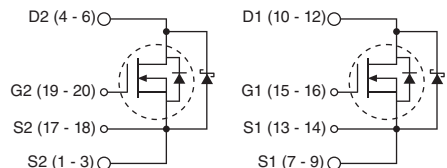

6-Pack MOSFET Module

QJE0130018, QJE0130021

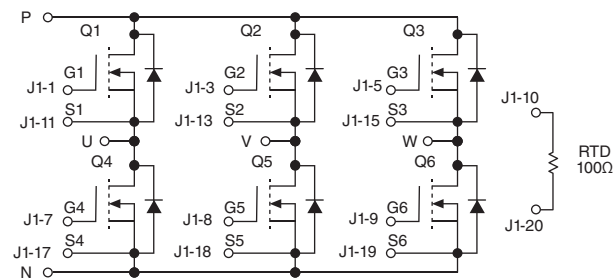

Numbering System

QJD1210010 is a 1200V, 100A, Split Dual SiC MOSFET Module

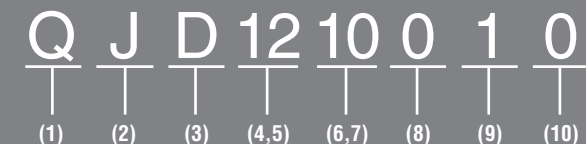

Serial Designation (SPECIAL)

- (1) Product Line
- (2) Device:
J = MOSFET
- (3) Configuration:
D = Split Dual
E = 6-Pack
S = Single
- (4,5) Voltage:
01 = 100V
05 = 500V
12 = 1200V
- (6,7) Current:
10 = 100
12 = 120
30 = 300

Serial Designation

- SPECIAL:**
- (8) 0 - 9 (Numbered from 001 - 999 for each individual combination of
 - (9) 0 - 9
 - (10) 0 - 9 (7 previous digits.)

1

QID1210005, QID1210006, QID1210007, QID1215003

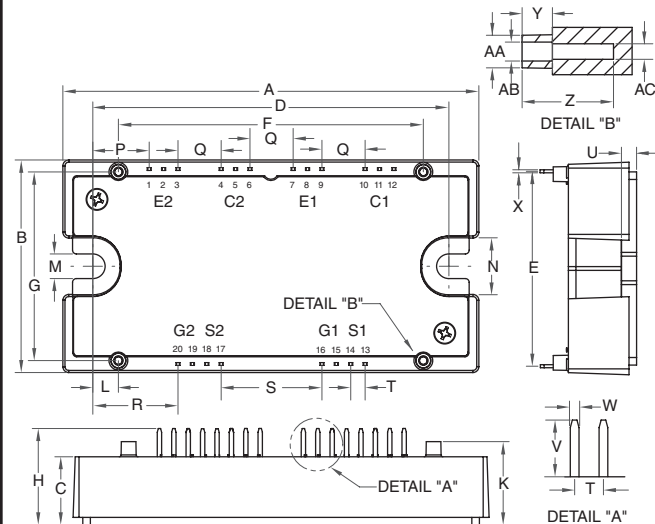

2

QJD1210010, QJD1210011, QJD1210SA1, QJD1210SA2

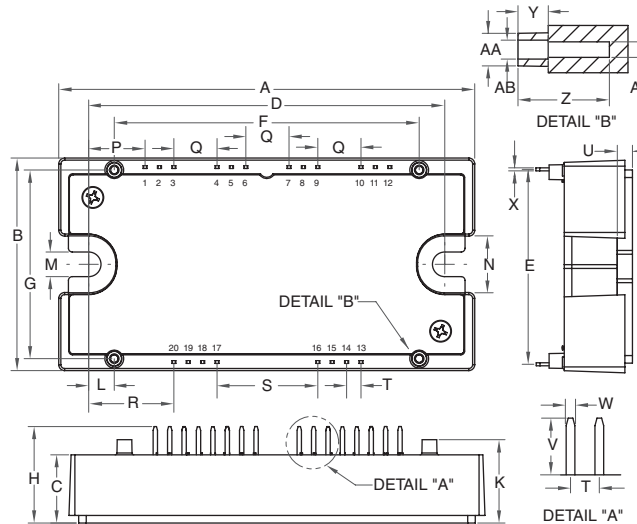

3

QRD1210004, QRD1210005

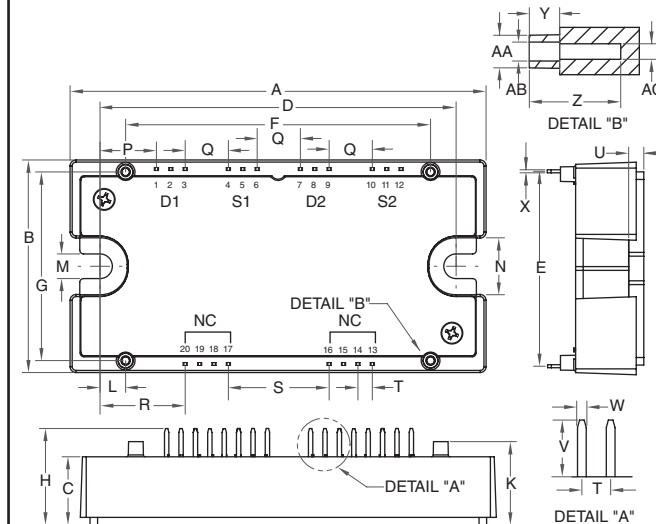

Dim.	Inches	Millimeters
A	4.32	109.8
B	2.21	56.1
C	0.71	18.0
D	3.70±0.02	94.0±0.5
E	2.026	51.46
F	3.17	80.5
G	1.96	49.8
H	1.00	25.5
K	0.87	22.0
L	0.266	6.75
M	0.26	6.5
N	0.59	15.0
P	0.586	14.89

Dim.	Inches	Millimeters
Q	0.449	11.40
R	0.885	22.49
S	1.047	26.6
T	0.15	3.80
U	0.16	4.0
V	0.30	7.5
W	0.045	1.15
X	0.03	0.8
Y	0.16	4.0
Z	0.47	12.1
AA	0.17 Dia.	4.3 Dia.
AB	0.10 Dia.	2.5 Dia.
AC	0.08 Dia.	2.1 Dia.

Dim.	Inches	Millimeters
A	4.32	109.8
B	2.21	56.1
C	0.71	18.0
D	3.70±0.02	94.0±0.5
E	2.026	51.46
F	3.17	80.5
G	1.96	49.8
H	1.00	25.5
K	0.87	22.0
L	0.266	6.75
M	0.26	6.5
N	0.59	15.0
P	0.586	14.89

Dim.	Inches	Millimeters
Q	0.449	11.40
R	0.885	22.49
S	1.047	26.6
T	0.15	3.80
U	0.16	4.0
V	0.30	7.5
W	0.045	1.15
X	0.03	0.8
Y	0.16	4.0
Z	0.47	12.1
AA	0.17 Dia.	4.3 Dia.
AB	0.10 Dia.	2.5 Dia.
AC	0.08 Dia.	2.1 Dia.

Dim.	Inches	Millimeters
A	4.32	109.8
B	2.21	56.1
C	0.71	18.0
D	3.70±0.02	94.0±0.5
E	2.026	51.46
F	3.17	80.5
G	1.96	49.8
H	1.00	25.5
K	0.87	22.0
L	0.266	6.75
M	0.26	6.5
N	0.59	15.0
P	0.586	14.89

Dim.	Inches	Millimeters
Q	0.449	11.40
R	0.885	22.49
S	1.047	26.6
T	0.15	3.80
U	0.16	4.0
V	0.30	7.5
W	0.045	1.15
X	0.03	0.8
Y	0.16	4.0
Z	0.47	12.1
AA	0.17 Dia.	4.3 Dia.
AB	0.10 Dia.	2.5 Dia.
AC	0.08 Dia.	2.1 Dia.

DC-DC
Converters

Gate Drivers
& IPM
Interface

Custom
Modules

IGBT
Assemblies

Assemblies

Fast Recovery
Diode Modules

Thyristor &
Diode
Modules

Discrete
Rectifiers

Discrete
Thyristors

DIPIPM

IPMs

MOSFET
Modules

Hybrid
& SiC
Modules

IGBTs

4

QJS0512001

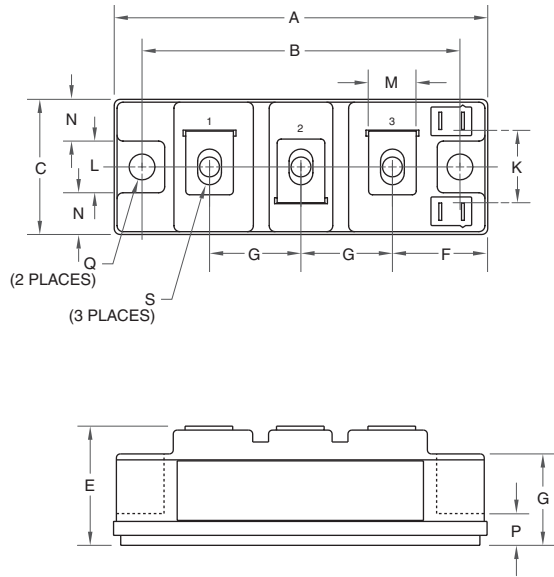

Dim.	Inches	Millimeters	Dim.	Inches	Millimeters
A	3.70	94.0	K	M6 Metric	M6
B	1.34	34.0	L	0.31	8.0
C	1.18	30.0	M	0.256 Dia.	6.5 Dia.
D	3.15	80.0	N	0.47	12.0
E	0.50	12.7	P	1.13	28.7
F	0.28	7.0	Q	0.10	2.5
G	0.67	17.0	R	0.84	21.3
H	0.91	23.0	S	0.21	5.3
J	0.91	23.0	T	0.24	6.1

5

QJE0130018, QJE0130021

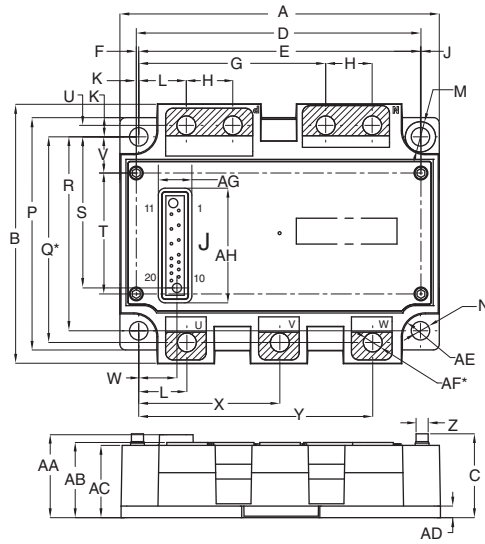

Dim.	Inches	Millimeters	Dim.	Inches	Millimeters
A	4.33	109.98	S	2.06	51.816
B	3.54	89.91	T	1.64	41.656
C	1.17 Max.	29.72 Max.	U	0.16	4.0
D	3.86	98.04	V	0.49	12.446
E	3.82	97.03	W	0.52	13.208
F	0.03	0.76	X	1.91	48.514
G	2.54	64.52	Y	3.17	80.518
H	0.63	16.0	Z	0.14 Dia.	3.556 Dia.
J	0.01	0.254	AA	1.12	28.448
K	0.26	6.604	AB	1.04 ±0.25	26.416 ±6.35
L	0.65	16.51	AC	0.98	24.892
M	0.41 Dia.	10.414 Dia.	AD	0.157 ±0.006	3.9878 ±0.152
N	0.25 Dia.	6.35	AE	0.36 Rad.	9.144 Rad.
P	3.15	80.01	AF	0.30 Dia.	7.62
Q	2.80	71.12	AG	0.46	11.684
R	2.63	66.802	AH	1.58	40.132

All dimensions are ±0.02 inches unless otherwise specified.

MOSFET Modules

Applications Include:

- Chopper
- Forklifts
- Off-Road Electric Vehicles
- Power Supplies

Circuit Configurations:

- 6-Pac
- Chopper (By Paralleling Legs)
- Dual (By Paralleling Legs)

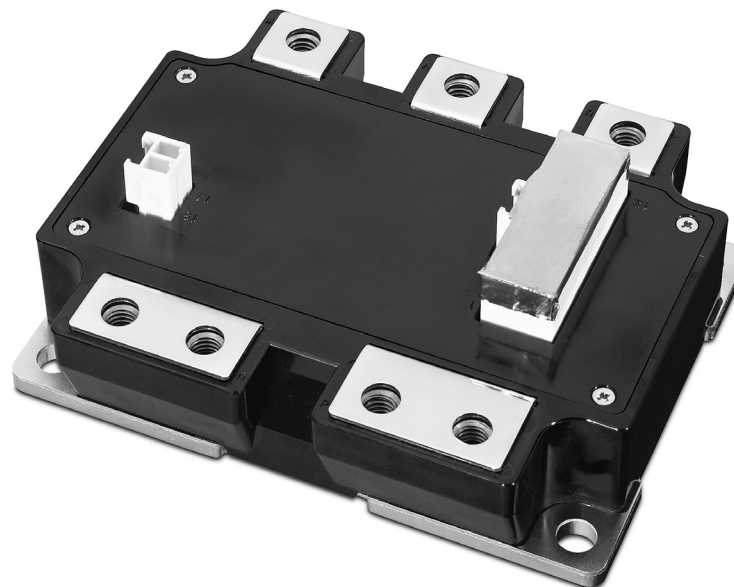

TABLE OF CONTENTS

Numbering System	C-2
MOSFET Modules.....	C-2
Outline Drawings.....	C-3

VOLTAGE: 75V TO 150V
CURRENT: 200A TO 600A

MOSFET Modules, (Refer to device datasheets at www.pwr.com for test conditions.)

MAXIMUM RATINGS						ELECTRICAL CHARACTERISTICS								THERMAL CHARACTERISTICS			
Type	V _{DSS} Volts	I _D Amperes	I _D (1) Amperes	P _d Watts	V _{RMS} Isolation Volts	V _{DS} = 10V, V _{GS} = 0V								Interface Per Module	Weight Grams	Outline Drawings	
						R _{DS(on)} mΩ	V _{SD} Volts	C _{ISS} nF	C _{RSS} nF	Q _G nC	Q _{rr} μC	t _{rr} ns	R _{th(j-c)} °C/W		Number	Page	
75V Modules																	
FM200TU-07A	75	200	600	560	2500	1.2	1.3	50	4.0	700	2.0	200	0.22	600	1	C-3	
FM400TU-07A	75	400	1200	650	2500	0.8	1.3	75	6.0	1100	4.5	200	0.142	600	1	C-3	
FM600TU-07A	75	600	1800	1300	2500	0.53	1.3	110	10.0	1650	4.8	200	0.096	600	1	C-3	
100V Modules																	
FM200TU-2A	100	200	600	560	2500	2.4	1.3	50	4.0	760	3.6	250	0.22	600	1	C-3	
FM400TU-2A	100	400	1200	880	2500	1.45	1.3	75	6.0	1200	6.0	250	0.142	600	1	C-3	
FM600TU-2A	100	600	1800	1300	2500	0.8	1.3	110	10.0	1800	6.2	250	0.096	600	1	C-3	
150V Modules																	
FM200TU-3A	150	200	600	560	2500	4.8	1.3	50	4.0	820	6.5	200	0.22	600	1	C-3	
FM400TU-3A	150	400	1200	880	2500	2.6	1.3	75	6.0	1300	7.0	200	0.142	600	1	C-3	
FM600TU-3A	150	600	1800	1300	2500	1.6	1.3	110	10.0	1950	8.0	200	0.096	600	1	C-3	

(1) Current rating when wired as a Dual or Chopper

6-Pac MOSFET Modules

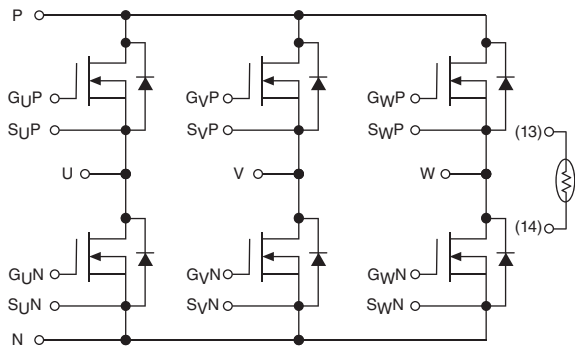

OR Dual MOSFET Module (By Paralleling)

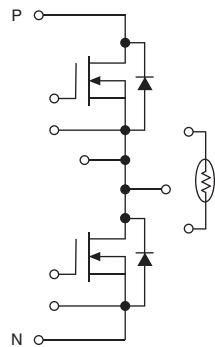

OR Chopper MOSFET Module (By Paralleling)

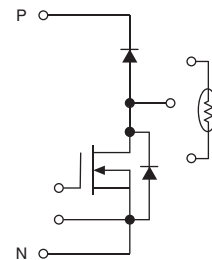

Numbering System

FM400TU-2A is a 400 Ampere, 100 Volt, 6-Pac MOSFET Module

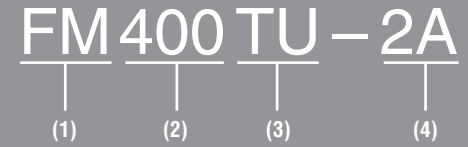

- (1) FM = MOSFET
- (2) Current Rating: I_D (Amperes)
- (3) TU = 6-Pac
- (4) Drain Source Voltage, V_{DSS}:
07A = 75V
2A = 100V
3A = 150V

1

FM200TU-07A, FM200TU-2A, FM200TU-3A,
 FM400TU-07A, FM400TU-2A, FM400TU-3A,
 FM600TU-07A, FM600TU-2A, FM600TU-3A

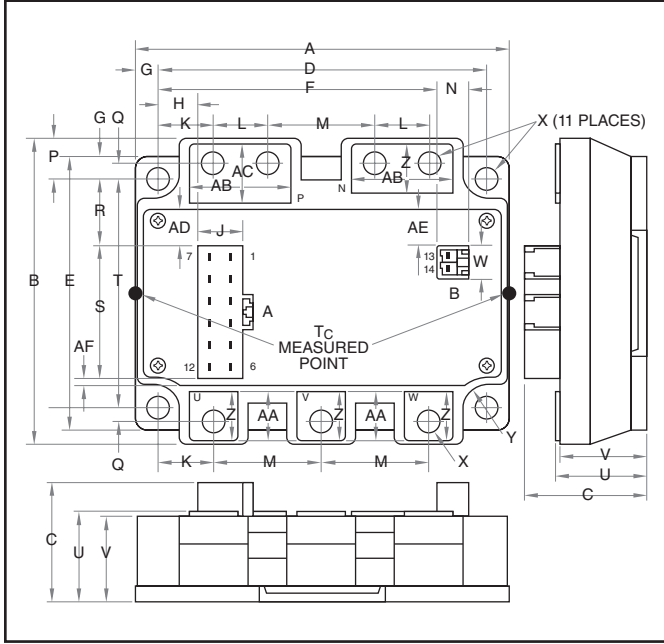

Dim.	Inches	Millimeters	Dim.	Inches	Millimeters
A	4.33	110.0	R	0.79	20.0
B	3.54	90.0	S	1.50	38.0
C	1.38	35.0	T	2.64	67.0
D	3.82	97.0	U	1.02	26.0
E	3.15	80.0	V	0.98	25.0
F	3.27	83.0	W	0.36	9.1
G	0.26	6.5	X	Dia. 0.25	Dia. 6.5
H	0.48	12.0	Y	Rad. 0.25	Rad. 6.5
J	0.51	12.9	Z	0.57	14.5
K	0.65	16.5	AA	0.55	14.0
L	0.63	16.0	AB	1.18	30.0
M	1.26	32.0	AC	0.69	17.5
N	0.35	8.8	AD	0.47	12.0
P	0.45	11.5	AE	0.61	15.5
Q	0.16	4.0	AF	0.18	4.5

Housing Types (Tyco Amp)

A 917354-1
 B 177898-1

IPMs

Applications Include:

- Hybrid Electric Vehicles (HEV / EV)
- Motor Drives
- Photovoltaic (PV) Inverters
- Power Supplies
- Servo Drives
- UPS

Circuit Configurations:

- Dual
- H-Bridge [+ Chopper(s)]
- 6-Pac
- 7-Pac

Features:

- Integrated Gate Drive
- Gate Drive Undervoltage (UV) Lockout
- Over Temperature Protection
- Short Circuit (SC) Protection Using On-Chip Current Sensor

*Development Kits available for some types.
(See Section N, DC-DC Converters)*

TABLE OF CONTENTS

Numbering System	D-2
L1-Series Photovoltaics (600V)	D-2
L1-Series & L-Series 6-Pac & 7-Pac	
600V	D-3
1200V	D-4
V1-Series Duals	D-5
Outline Drawings	D-6



VOLTAGE: 600V TO 1200V
CURRENT: 25A TO 800A

Photovoltaic 600V L1-Series Intelligent Power Modules,

(Refer to device datasheets at www.pwr.com for test conditions.)



MAXIMUM RATINGS (IGBT Inverter Sector)					ELECTRICAL CHARACTERISTICS (IGBT Inverter Sector)										PROTECTION TRIP LEVELS			THERMAL CHARACTERISTICS			Outline Drawings			
Type	V _{CES} Volts	I _C Amperes	P _d Watts	V _{RMS} Isolation Volts	Typ. V _{CE(SAT)} Volts	V _{EC} Volts	I _{CES} mA	V _{CC(PROT)} Volts	Brake I _C Amperes	Inductive Load Switching Times					SC Amperes	OT °C	UV Volts	R _{th(c-f)} °C/W	IGBT R _{th(j-c)} °C/W	DIODES R _{th(j-c)} °C/W	Weight Grams	Number		Page
										t _(on) μsec	t _{rr} μsec	t _{c(on)} μsec	t _(off) μsec	t _{c(off)} μsec								3	6	
PM50B4L1C060	600	50	168	2500	1.9	1.7	1.0	400	—	0.8	0.4	0.4	1.0	0.3	75	135	12	0.06	0.74	1.28	135	3	3	D-6
PM50B5L1C060	600	50	168	2500	1.9	1.7	1.0	400	50	0.8	0.4	0.4	1.0	0.3	75	135	12	0.06	0.74	1.28	135	3	3	D-6
PM50B6L1C060	600	50	168	2500	1.9	1.7	1.0	400	50	0.8	0.4	0.4	1.0	0.3	75	135	12	0.06	0.74	1.28	135	3	3	D-6
PM75B4L1C060	600	75	337	2500	1.9	1.7	1.0	400	—	0.8	0.4	0.4	1.0	0.3	112	135	12	0.06	0.37	0.63	135	3	3	D-6
PM75B5L1C060	600	75	337	2500	1.9	1.7	1.0	400	75	0.8	0.4	0.4	1.0	0.3	112	135	12	0.06	0.37	0.63	135	3	3	D-6
PM75B6L1C060	600	75	337	2500	1.9	1.7	1.0	400	75	0.8	0.4	0.4	1.0	0.23	112	135	12	0.06	0.37	0.63	135	3	3	D-6

H-Bridge Module

PM50B4L1C060, PM75B4L1C060

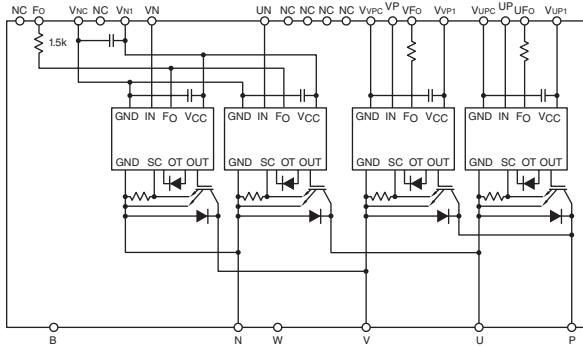

H-Bridge + 1 Chopper Module

PM50B5L1C060, PM75B5L1C060

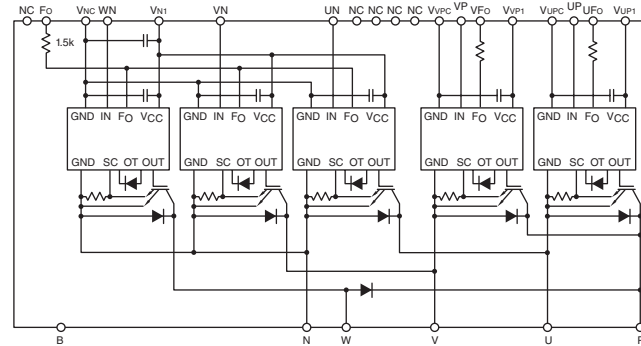

H-Bridge + 2 Choppers Module

PM50B6L1C060, PM75B6L1C060

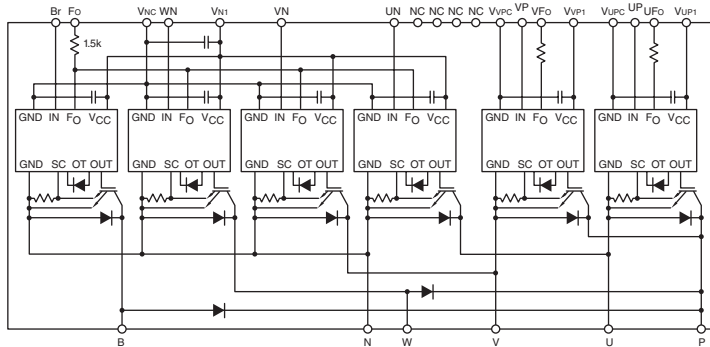

Numbering System

PM150RL1A120 is a 150 Ampere, 1200 Volt, 7-Pac L1-Series IPM



- (1) PM = Intelligent Power Module (IPM)
- (2) Current Rating: I_C (Amperes)
- (3) C = 6-Pac
R = 7-Pac
B4 = H-Bridge
B5 = H-Bridge + 1 Chopper
B6 = H-Bridge + 2 Choppers
H = Single
D = Dual
- (4) L = L-Series
L1 = L1-Series
C = HVIPM
V1 = V1-Series
- (5) Package Outline
- (6) Voltage V_{CES} Volts (x10)

L1-Series & L-Series 6-Pac & 7-Pac 600V Intelligent Power Modules,

(Refer to device datasheets at www.pwr.com for test test conditions.)



PM50RL1C060



PM50CL1A060, PM50RL1A060,
PM75CL1A060, PM75RL1A060,
PM100CL1A060, PM100RL1A060,
PM150CL1A060, PM150RL1A060



PM50CL1B060, PM50RL1B060,
PM75CL1B060, PM75RL1B060,
PM100CL1B060, PM100RL1B060,
PM150CL1B060, PM150RL1B060

MAXIMUM RATINGS (IGBT Inverter Sector)					ELECTRICAL CHARACTERISTICS (IGBT Inverter Sector)										PROTECTION TRIP LEVELS			THERMAL CHARACTERISTICS			Outline Drawings		
Type	V _{CES} Volts	I _C Amperes	P _d Watts	V _{RMS} Isolation Volts	Typ. V _{CE(SAT)} Volts	V _{EC} Volts	I _{CES} mA	V _{CC(PROT)} Volts	Brake I _C Amperes	Inductive Load Switching Times					SC Amperes	OT °C	UV Volts	R _{th(c-f)} °C/W	IGBT R _{th(j-c)} °C/W	DIODES R _{th(j-c)} °C/W	Weight Grams	Number	Page
										t _(on) µsec	t _{rr} µsec	t _{c(on)} µsec	t _(off) µsec	t _{c(off)} µsec									
L1-Series Modules																							
PM50CL1A060	600	50	284	2500	1.75	1.70	1.0	400	—	0.8	0.4	0.4	1.0	0.3	100	135	12	0.038	0.44	0.75	380	1	D-6
PM50CL1B060	600	50	284	2500	1.75	1.70	1.0	400	—	0.8	0.4	0.4	1.0	0.3	100	135	12	0.038	0.44	0.75	340	2	D-6
PM50RL1A060	600	50	284	2500	1.75	1.70	1.0	400	50	0.8	0.4	0.4	1.0	0.3	100	135	12	0.038	0.44	0.75	380	1	D-6
PM50RL1B060	600	50	284	2500	1.75	1.70	1.0	400	50	0.8	0.4	0.4	1.0	0.3	100	135	12	0.038	0.44	0.75	340	2	D-6
PM50RL1C060	600	50	168	2500	1.75	1.70	1.0	400	50	0.8	0.4	0.4	1.0	0.3	100	135	12	0.085	0.74	1.28	135	3	D-6
PM75CL1A060	600	75	337	2500	1.75	1.70	1.0	400	—	0.8	0.4	0.4	1.0	0.3	150	135	12	0.038	0.37	0.63	380	1	D-6
PM75CL1B060	600	75	337	2500	1.75	1.70	1.0	400	—	0.8	0.4	0.4	1.0	0.3	150	135	12	0.038	0.37	0.63	340	2	D-6
PM75RL1A060	600	75	337	2500	1.75	1.70	1.0	400	50	0.8	0.4	0.4	1.0	0.3	150	135	12	0.038	0.37	0.63	380	1	D-6
PM75RL1B060	600	75	337	2500	1.75	1.70	1.0	400	50	0.8	0.4	0.4	1.0	0.3	150	135	12	0.038	0.37	0.63	340	2	D-6
PM100CL1A060	600	100	390	2500	1.75	1.70	1.0	400	—	0.8	0.4	0.4	1.0	0.3	200	135	12	0.038	0.32	0.52	380	1	D-6
PM100CL1B060	600	100	390	2500	1.75	1.70	1.0	400	—	0.8	0.4	0.4	1.0	0.3	200	135	12	0.038	0.32	0.52	340	2	D-6
PM100RL1A060	600	100	390	2500	1.75	1.70	1.0	400	50	0.8	0.4	0.4	1.0	0.3	200	135	12	0.038	0.32	0.52	380	1	D-6
PM100RL1B060	600	100	390	2500	1.75	1.70	1.0	400	50	0.8	0.4	0.4	1.0	0.3	200	135	12	0.038	0.32	0.52	340	2	D-6
PM150CL1A060	600	150	500	2500	1.75	1.70	1.0	400	—	0.8	0.4	0.4	1.0	0.3	300	135	12	0.038	0.25	0.41	380	1	D-6
PM150CL1B060	600	150	500	2500	1.75	1.70	1.0	400	—	0.8	0.4	0.4	1.0	0.3	300	135	12	0.038	0.25	0.41	340	2	D-6
PM150RL1A060	600	150	500	2500	1.75	1.70	1.0	400	75	0.8	0.4	0.4	1.0	0.3	300	135	12	0.038	0.25	0.41	380	1	D-6
PM150RL1B060	600	150	500	2500	1.75	1.70	1.0	400	75	0.8	0.4	0.4	1.0	0.3	300	135	12	0.038	0.25	0.41	340	2	D-6
PM200CL1A060	600	200	625	2500	1.75	1.70	1.0	400	—	0.8	0.4	0.4	1.0	0.3	400	135	12	0.023	0.2	0.3	800	4	D-7
PM200RL1A060	600	200	625	2500	1.75	1.70	1.0	400	100	0.8	0.4	0.4	1.0	0.3	400	135	12	0.023	0.2	0.3	800	4	D-7
PM300CL1A060	600	300	833	2500	1.75	1.70	1.0	400	—	0.8	0.4	0.4	1.0	0.3	600	135	12	0.023	0.15	0.23	800	4	D-7
PM300RL1A060	600	300	833	2500	1.75	1.70	1.0	400	150	0.8	0.4	0.4	1.0	0.3	600	135	12	0.023	0.15	0.23	800	4	D-7
L-Series Modules																							
PM450CLA060	600	450	1041	2500	1.70	2.60	1.0	400	—	1.0	0.2	0.4	2.2	0.6	900	135	12	0.014	0.12	0.19	1250	5	D-7
PM600CLA060	600	600	1785	2500	1.70	2.60	1.0	400	—	1.0	0.2	0.4	2.2	0.6	1200	135	12	0.014	0.07	0.11	1250	5	D-7

PM50CL1A060, PM50CL1B060, PM75CL1A060, PM75CL1B060, PM100CL1A060,
PM100CL1B060, PM150CL1A060, PM150CL1B060, PM200CL1A060, PM300CL1A060

PM50RL1A060, PM50RL1B060, PM50RL1C060, PM75RL1A060, PM75RL1B060, PM100RL1A060,
PM100RL1B060, PM150RL1A060, PM150RL1B060, PM200RL1A060, PM300RL1A060

PM450CLA060, PM600CLA060

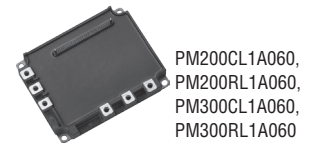
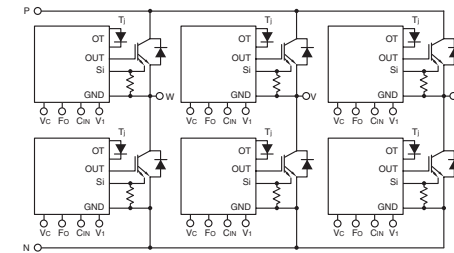
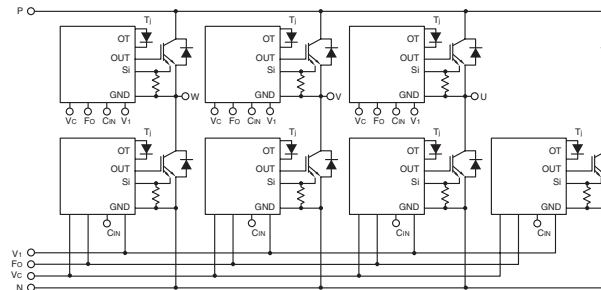
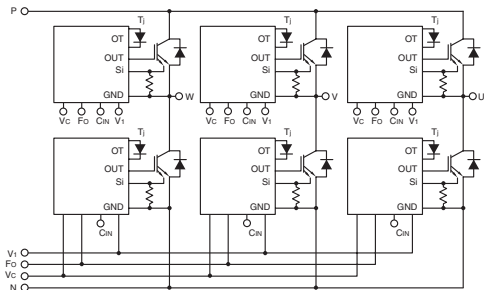

PM200CL1A060,
PM200RL1A060,
PM300CL1A060,
PM300RL1A060

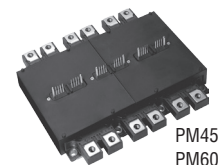

PM450CLA060,
PM600CLA060

L1-Series & L-Series 6-Pac & 7-Pac 1200V Intelligent Power Modules

(Refer to device datasheets at www.pwr.com for test test conditions.)



PM25RL1A120



PM25CL1A120, PM25RL1A120,
PM50CL1A120, PM50RL1A120,
PM75CL1A120, PM75RL1A120

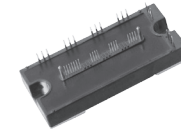

PM25CL1B120, PM25RL1B120,
PM50CL1B120, PM50RL1B120,
PM75CL1B120, PM75RL1B120

MAXIMUM RATINGS (IGBT Inverter Sector)					ELECTRICAL CHARACTERISTICS (IGBT Inverter Sector)											PROTECTION TRIP LEVELS			THERMAL CHARACTERISTICS			Outline Drawings	
Type	V _{CES} Volts	I _C Amperes	P _d Watts	V _{RMS} Isolation Volts	Typ. V _{CE(SAT)} Volts	V _{EC} Volts	I _{CES} mA	V _{CC(PROT)} Volts	Brake I _C Amperes	Inductive Load Switching Times					SC Amperes	OT °C	UV Volts	R _{th(c-f)} °C/W	R _{th(j-c)} °C/W	R _{th(j-c)} °C/W	Weight Grams	Outline Drawings	
										t _(on) μsec	t _{rr} μsec	t _{c(on)} μsec	t _(off) μsec	t _{c(off)} μsec								Number	Page
L1-Series Modules																							
PM25CL1A120	1200	25	128	2500	1.65	2.30	1.0	800	-	0.8	0.3	0.4	1.2	0.4	50	135	12	0.038	0.97	1.6	380	1	D-6
PM25CL1B120	1200	25	128	2500	1.65	2.30	1.0	800	-	0.8	0.3	0.4	1.2	0.4	50	135	12	0.038	0.97	1.6	340	2	D-6
PM25RL1A120	1200	25	128	2500	1.65	2.30	1.0	800	25	0.8	0.3	0.4	1.2	0.4	50	135	12	0.038	0.97	1.6	380	1	D-6
PM25RL1B120	1200	25	128	2500	1.65	2.30	1.0	800	25	0.8	0.3	0.4	1.2	0.4	50	135	12	0.038	0.97	1.6	340	2	D-6
PM25RL1C120	1200	25	178	2500	1.65	2.30	1.0	800	25	0.8	0.3	0.4	1.5	0.4	50	135	12	0.085	0.7	1.18	135	3	D-6
PM50CL1A120	1200	50	462	2500	1.65	2.30	1.0	800	-	0.8	0.3	0.4	1.2	0.4	100	135	12	0.038	0.27	0.47	380	1	D-6
PM50CL1B120	1200	50	462	2500	1.65	2.30	1.0	800	-	0.8	0.3	0.4	1.2	0.4	100	135	12	0.038	0.27	0.47	340	2	D-6
PM50RL1A120	1200	50	462	2500	1.65	2.30	1.0	800	25	0.8	0.3	0.4	1.2	0.4	100	135	12	0.038	0.27	0.47	380	1	D-6
PM50RL1B120	1200	50	462	2500	1.65	2.30	1.0	800	25	0.8	0.3	0.4	1.2	0.4	100	135	12	0.038	0.27	0.47	340	2	D-6
PM75CL1A120	1200	75	595	2500	1.65	2.30	1.0	800	-	0.8	0.3	0.4	1.2	0.4	150	135	12	0.038	0.21	0.36	380	1	D-6
PM75CL1B120	1200	75	595	2500	1.65	2.30	1.0	800	-	0.8	0.3	0.4	1.2	0.4	150	135	12	0.038	0.21	0.36	340	2	D-6
PM75RL1A120	1200	75	595	2500	1.65	2.30	1.0	800	50	0.8	0.3	0.4	1.2	0.4	150	135	12	0.038	0.21	0.36	380	1	D-6
PM75RL1B120	1200	75	595	2500	1.65	2.30	1.0	800	50	0.8	0.3	0.4	1.2	0.4	150	135	12	0.038	0.21	0.36	340	2	D-6
PM100CL1A120	1200	100	657	2500	1.65	2.30	1.0	800	-	0.8	0.3	0.4	1.2	0.4	200	135	12	0.023	0.19	0.31	800	4	D-7
PM100RL1A120	1200	100	657	2500	1.65	2.30	1.0	800	50	0.8	0.3	0.4	1.2	0.4	200	135	12	0.023	0.25	0.41	800	4	D-7
PM150CL1A120	1200	150	833	2500	1.65	2.30	1.0	800	-	0.8	0.3	0.4	1.2	0.4	300	135	12	0.023	0.19	0.31	800	4	D-7
PM150RL1A120	1200	150	833	2500	1.65	2.30	1.0	800	75	0.8	0.3	0.4	1.2	0.4	300	135	12	0.023	0.19	0.31	800	4	D-7
L-Series Modules																							
PM200CLA120	1200	200	1041	2500	1.80	2.80	1.0	800	-	1.0	0.5	0.4	2.3	0.7	400	135	12	0.014	0.12	0.2	1250	5	D-7
PM300CLA120	1200	300	1562	2500	1.80	2.80	1.0	800	-	1.0	0.5	0.4	2.3	0.7	600	135	12	0.014	0.08	0.13	1250	5	D-7
PM450CLA120	1200	450	2500	2500	1.80	2.80	1.0	800	-	1.0	0.5	0.4	2.3	0.7	900	135	12	0.014	0.05	0.09	1250	5	D-7

PM25CL1A120, PM25CL1B120, PM50CL1A120, PM50CL1B120, PM75CL1A120, PM75CL1B120, PM100CL1A120, PM150CL1A120

PM25RL1A120, PM25RL1B120, PM25RL1C120, PM50RL1A120, PM50RL1B120, PM75RL1A120, PM75RL1B120, PM100RL1A120, PM150RL1A120

PM200CLA120, PM300CLA120, PM450CLA120

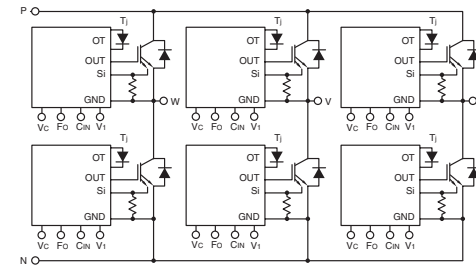
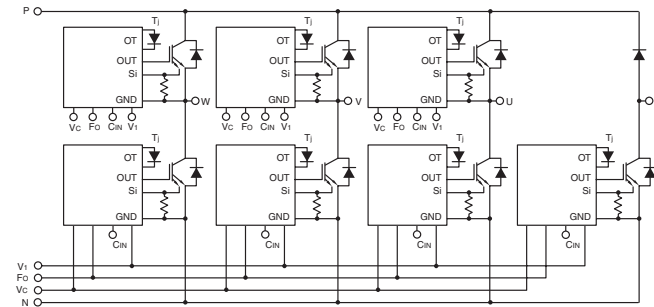
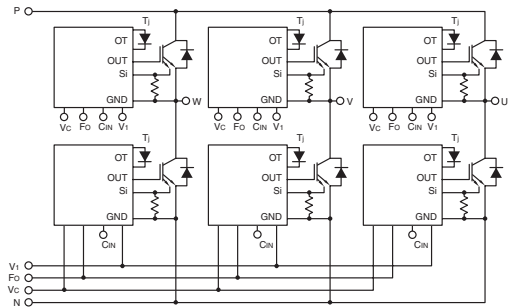

PM100CL1A120,
PM100RL1A120,
PM150CL1A120,
PM150RL1A120

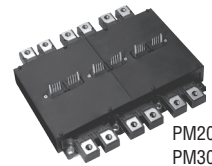

PM200CLA120,
PM300CLA120,
PM450CLA120

V1-Series Dual Intelligent Power Modules,

(Refer to device datasheets at www.pwr.com for test test conditions.)



PM400DV1A060, PM600DV1A060,
PM200DV1A120, PM300DV1A120,
PM450DV1A120



PM800DV1B060

MAXIMUM RATINGS (IGBT Inverter Sector)					ELECTRICAL CHARACTERISTICS (IGBT Inverter Sector)										PROTECTION TRIP LEVELS			THERMAL CHARACTERISTICS			Outline Drawings		
Type	V _{CES} Volts	I _C Amperes	P _d Watts	V _{RMS} Isolation Volts	Typ. V _{CE(SAT)} Volts	V _{EC} Volts	I _{CES} mA	V _{CC(PROT)} Volts	Inductive Load Switching Times					SC Amperes	OT °C	UV Volts	R _{th(c-f)} °C/W	IGBT R _{th(j-c)} °C/W	DIODES R _{th(j-c)} °C/W	Weight Grams	Number		Page
									t _(on) μsec	t _{rr} μsec	t _{c(on)} μsec	t _(off) μsec	t _{c(off)} μsec								6	7	
600V Dual Modules																							
PM400DV1A060	600	400	1262	2500	1.75	1.75	1.0	400	0.8	0.4	0.4	1.0	0.3	600	135	12	0.016	0.099	0.153	510	6	D-7	
PM600DV1A060	600	600	1712	2500	1.75	1.70	1.0	400	0.8	0.3	0.4	1.0	0.3	900	135	12	0.016	0.073	0.109	510	6	D-7	
PM800DV1B060	600	800	2500	2500	1.85	1.70	1.0	400	0.8	0.25	0.4	1.4	0.3	1200	135	12	0.014	0.05	0.09	720	7	D-8	
1200V Dual Modules																							
PM200DV1A120	1200	200	1388	2500	1.65	2.30	1.0	800	0.8	0.3	0.4	1.2	0.4	300	135	12	0.016	0.09	0.146	510	6	D-7	
PM300DV1A120	1200	300	1785	2500	1.65	2.30	1.0	800	0.8	0.3	0.4	1.2	0.4	450	135	12	0.016	0.07	0.11	510	6	D-7	
PM450DV1A120	1200	450	2232	2500	1.65	2.30	1.0	800	0.8	0.3	0.4	1.2	0.4	675	135	12	0.016	0.056	0.079	510	6	D-7	

V1-Series, Duals

PM400DV1A060, PM600DV1A060, PM800DV1B060,
PM200DV1A120, PM300DV1A120, PM450DV1A120

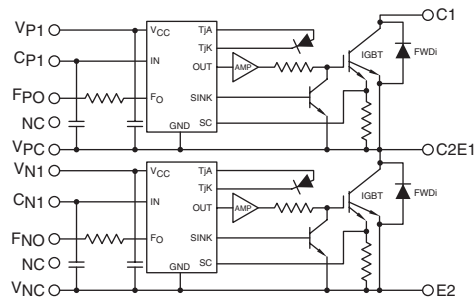

1

PM25CL1A120, PM25RL1A120, PM50CL1A060, PM50RL1A120, PM50RL1A060, PM50RL1A120, PM75CL1A060, PM75CL1A120, PM75RL1A060, PM75RL1A120, PM100CL1A060, PM100RL1A060, PM150CL1A060, PM150RL1A060

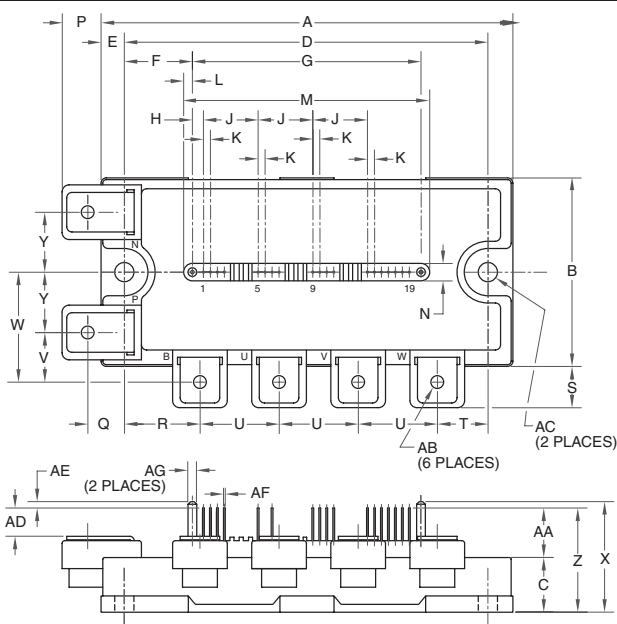

2

PM25CL1B120, PM25RL1B120, PM50CL1B060, PM50RL1B120, PM50RL1B060, PM50RL1B120, PM75CL1B060, PM75CL1B120, PM75RL1B060, PM75RL1B120, PM100CL1B060, PM100RL1B060, PM150CL1B060, PM150RL1B060

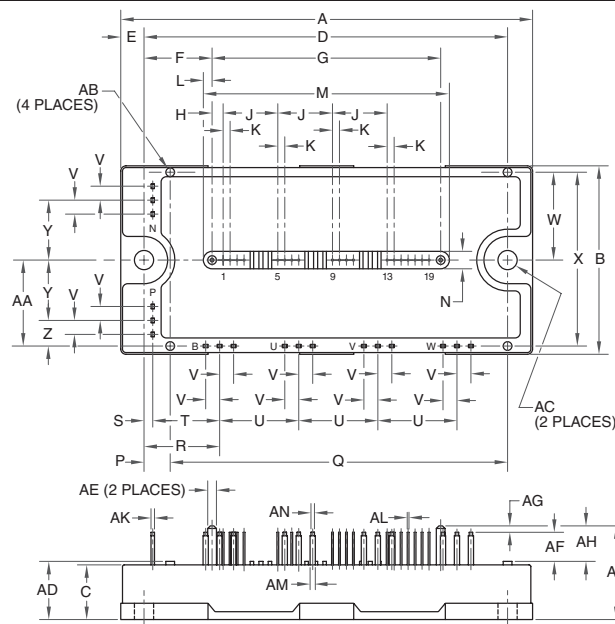

3

PM25RL1C120, PM50B4L1C060, PM50B5L1C060, PM50B6L1C060, PM50RL1C060, PM75B4L1C060, PM75B5L1C060, PM75B6L1C060

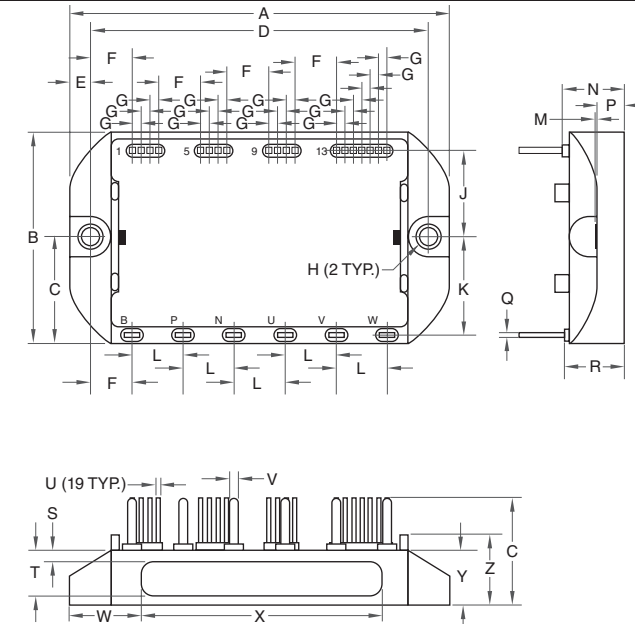

Dim.	Inches	Millimeters
A	4.72	120.0
B	2.17	55.0
C	0.63	16.0
D	4.17	106.0
E	0.28	7.0
F	0.78	19.75
G	2.62	66.5
H	0.13	3.25
J	0.63	16.0
K	0.08	2.0
L	0.10	2.5
M	2.81	71.5
N	0.20	5.0
P	0.43	11.0
Q	0.42	10.75
R	0.87	22.0

Dim.	Inches	Millimeters
S	0.46	11.75
T	0.59	15.0
U	0.91	23.0
V	0.57	14.5
W	1.26	32.0
X	1.22	31.0
Y	0.69	17.5
Z	1.14	29.0
AA	0.51	13.0
AB	M5 Metric	M5
AC	0.22 Dia.	5.5 Dia.
AD	0.28	7.0
AE	0.08	2.0
AF	0.02 Sq.	0.5 Sq.
AG	0.10 Dia.	2.5 Dia.

Dim.	Inches	Millimeters
A	4.72	120.0
B	2.17	55.0
C	0.63	16.0
D	4.17	106.0
E	0.28	7.0
F	0.78	19.75
G	2.62	66.5
H	0.13	3.25
J	0.63	16.0
K	0.08	2.0
L	0.10	2.5
M	2.81	71.5
N	0.20	5.0
P	0.31	7.75
Q	3.87	98.25
R	0.87	22.0
S	0.10	2.5
T	0.77	19.5
U	0.91	23.0

Dim.	Inches	Millimeters
V	0.16	4.0
W	1.01	25.75
X	2.00	50.75
Y	0.69	17.5
Z	0.30	7.5
AA	0.98	25.0
AB	0.10 Dia.	2.5 Dia.
AC	0.22 Dia.	5.5 Dia.
AD	0.67	17.0
AE	0.10 Dia.	2.5 Dia.
AF	0.33	8.5
AG	0.08	2.0
AH	0.41	10.5
AJ	1.08	27.5
AK	0.04	1.0
AL	0.02 Sq.	0.5 Sq.
AM	0.06	1.5
AN	0.04	1.0

Dim.	Inches	Millimeters
A	3.54	90.0
B	1.97	50.0
C	0.98	25.0
D	3.5	80.0
E	0.2	5.0
F	0.4	10.0
G	0.08	2.0
H	0.17 Dia.	4.3 Dia.
J	0.8	20.5
K	0.9	23.0
L	0.5	12.0
M	0.012	0.3

Dim.	Inches	Millimeters
N	0.58	14.6
P	0.26	6.7
Q	0.02	0.5
R	0.56	14.2
S	0.1±0.02	2.5±0.5
T	0.31	8.0
U	0.02 Sq.	0.5 Sq.
V	0.08	2.0
W	0.69±0.02	17.5±0.5
X	0.22	5.5
Y	0.52	13.0
Z	0.65	16.5

4

PM100CL1A120, PM100RL1A120, PM150CL1A120,
PM150RL1A120 PM200CL1A060, PM200RL1A060,
PM300CL1A060, PM300RL1A060,

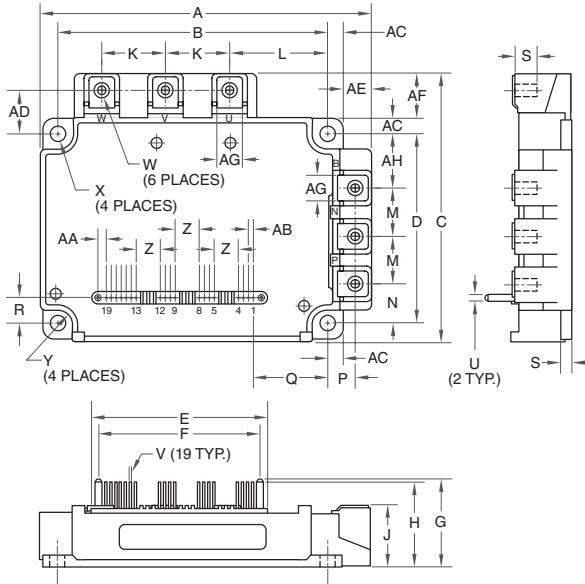

5

PM200CLA120, PM300CLA120, PM450CLA060,
PM450CLA120, PM600CLA060

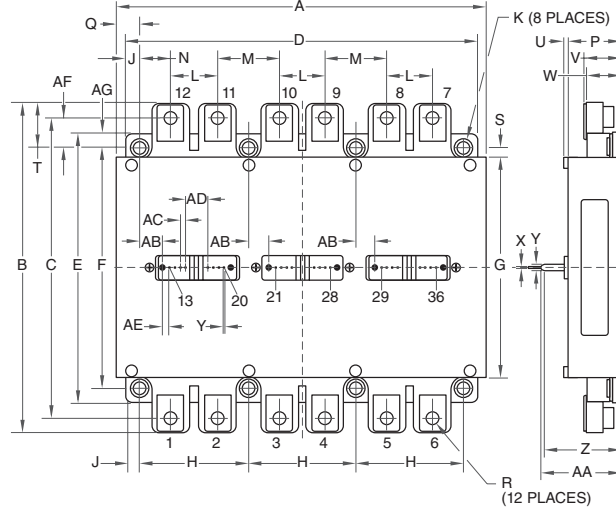

6

PM200DV1A120, PM300DV1A120, PM400DV1A060,
PM450DV1A120, PM600DV1A060,

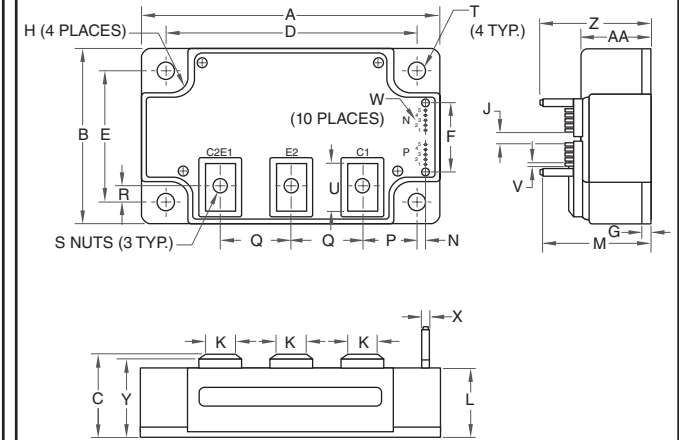

Dim.	Inches	Millimeters
A	5.31	135.0
B	4.33±0.02	110±0.5
C	4.33	110.0
D	3.07	78.0±0.5
E	2.81	71.5
F	2.62	66.5
G	1.37	34.7
H	1.32	33.6
J	0.95+0.04/-0.01	24.1+1.0/-0.5
K	1.02	26.0
L	1.59	40.5
M	0.79	20.0
N	0.65	16.5
P	0.43±0.01	11.0±0.3
Q	1.19	30.15
R	0.43	11.0

Dim.	Inches	Millimeters
S	0.51	13.0
T	0.16	4.0
U	0.1 Dia.	2.5 Dia.
V	0.02 Sq.	0.5 Sq.
W	M5 Metric	M5
X	0.22 Dia.	5.5 Dia.
Y	0.24 Rad.	6.0 Rad.
Z	0.39	10.0
AA	0.13	3.25
AB	0.08	2.0
AC	0.24	6.05
AD	0.71	18.0
AE	0.46	11.7
AF	0.74	18.7
AG	0.41	10.5
AH	0.85	21.5

Dim.	Inches	Millimeters
A	6.77	172.0
B	5.90	150.0
C	5.39	137.0
D	6.38	162.0
E	4.84	123.0
F	4.33	110.0
G	3.90	99.0
H	1.97	50.0
J	0.236	6.0
K	5.5 Metric	M5.5
L	0.866	22.0
M	1.10	28.0
N	0.55	14.0
P	0.945	24.0
Q	0.43	11.0
R	M6 Metric	M6

Dim.	Inches	Millimeters
S	0.217	5.5
T	0.79	20.0
U	0.08	2.0
V	0.67	17.0
W	0.62	15.8
X	0.025 Sq.	0.64 Sq.
Y	0.1 Dia.	2.5 Dia.
Z	1.40	35.5
AA	1.44	36.6
AB	0.36	9.08
AC	0.10	2.54
AD	0.40	10.16
AE	0.127	3.22
AF	0.53	13.5
AG	0.256	6.5

Dim.	Inches	Millimeters
A	4.72	120.0
B	2.76	70.0
C	1.14+0.04/-0.02	29.0+1.0/-0.5
D	4.17±0.01	106.0±0.3
E	2.20±0.01	56.0±0.3
F	1.52	38.5
G	0.16	4.0
H	0.26 Rad.	6.5 Rad.
J	0.40	10.16
K	0.55	14.0
L	1.02	26.0
M	1.53	39.0
N	0.12±0.02	3.0±0.5

Dim.	Inches	Millimeters
P	1.50	38.0
Q	0.98	25.0
R	0.37	9.3
S	M6 Metric	M6
T	0.26 Dia.	6.5 Dia.
U	0.72	18.3
V	0.10	2.54
W	0.025 Sq.	0.64 Sq.
X	0.14 Dia.	3.5 Dia.
Z	1.59	40.5
AA	1.14	29.0

DC-DC
ConvertersGate
DriversCustom
ModulesIGBT
Assemblies

Assemblies

Fast Recovery &
Rectifier Diode
ModulesThyristor &
Diode
ModulesDiscrete
RectifiersDiscrete
Thyristors

DIPIPM

IPMs

MOSFET
ModulesHybrid
& SiC
Modules

IGBTs

7 PM800DV1B060

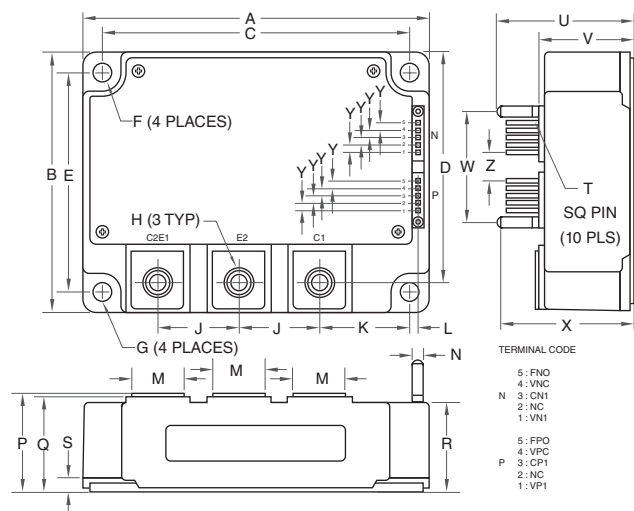

Dim.	Inches	Millimeters	Dim.	Inches	Millimeters
A	4.72	120.0	N	0.14 Dia.	3.5 Dia.
B	3.54	90.0	P	1.34+0.04/-0.02	34.0+1.0/-0.5
C	4.17±0.010	106.0±0.25	Q	1.29	32.8
D	2.87	73.0	R	1.22	31.0
E	2.99±0.010	76.0±0.25	S	0.16	4.0
F	0.26 Rad.	6.5 Rad.	T	0.025 Sq.	0.64 Sq.
G	0.26 Dia.	6.5 Dia.	U	1.79	45.5
H	M8 Metric	M8	V	1.34	34.0
J	1.10	28.0	W	1.52	38.5
K	1.22	31.0	X	1.73	44.0
L	0.12±0.02	3.0±0.5	Y	0.10	2.54
M	0.71	18.0	Z	0.40	10.16

DIIPM™

Applications Include:

- Servo / Motion Controls
- HVAC
- Home Appliances
- Pumps
- Low-capacity Industrial Inverters

Packages:

- Super Mini DIIPM
- Super Mini MOSFET DIIPM
- Mini DIIPM
- Large DIIPM

Circuit Configuration:

- 6-Pac
- PFC

Features:

- Gate Drive
- Gate Drive Undervoltage (UV) Lockout
- Short Circuit (SC) Protection

TABLE OF CONTENTS

Numbering System	E-2
Super Mini DIIPM Modules	E-2
Super Mini MOSFET DIIPM Modules	E-3
Mini DIIPM Modules	E-4
DIPPFC™ Modules	E-4
Large DIIPM Modules	E-5
Outline Drawings	E-6

DIIPM and DIPPFC are registered trademarks of Mitsubishi Electric Corp.

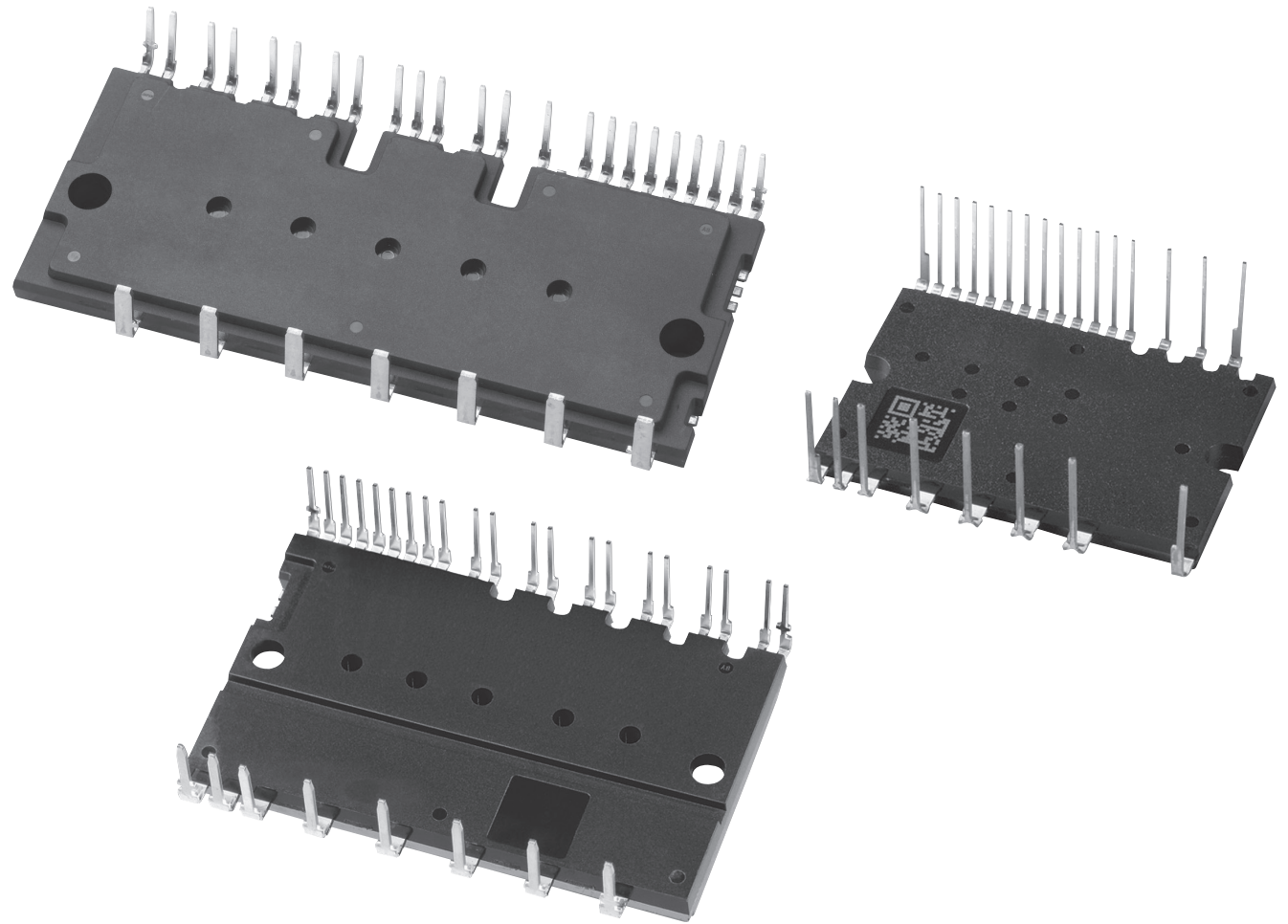

VOLTAGE: 500V TO 1200V
CURRENT: 3A TO 75A

DC-DC
Converters

Gate
Drivers

Custom
Modules

IGBT
Assemblies

Assemblies

Fast Recovery &
Rectifier Diode
Modules

Thyristor &
Diode
Modules

Discrete
Rectifiers

Discrete
Thyristors

DIIPM

IPMs

MOSFET
Modules

Hybrid
& SiC
Modules

IGBTs

Super Mini DIIPM 600V Modules - Version 6 Numbering System

(Refer to device datasheets at www.pwr.com for test conditions.)

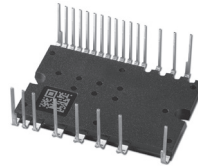

MAXIMUM RATINGS (IGBT Inverter Sector)					ELECTRICAL CHARACTERISTICS (IGBT Inverter Sector)					THERMAL CHARACTERISTICS		Weight Grams	Outline Drawing	
Type	V _{CES} Volts	I _C /I _{CP} Amperes	P _D Watts	V _{RMS} Isolation Volts	Typ. V _{CE(SAT)} Volts	V _{EC} Volts	I _{CES} mA	V _{CC(Prot)} Volts	t _{DEAD(Min)} usec	IGBT R _{th(j-c)} °C/W	Diode R _{th(j-c)} °C/W		Number	Page
PSS05S92F6-AG	600	5 / 10	20.0	1500*	1.50	1.70	1.0	400	1.0	5.0	5.7	8.5	1	E-6
PSS10S92F6-AG	600	10 / 20	21.3	1500*	1.75	2.50	1.0	400	1.0	4.7	5.4	8.5	1	E-6
PSS15S92F6-AG	600	15 / 30	27.0	1500*	1.75	2.50	1.0	400	1.0	3.7	4.5	8.5	1	E-6
PSS20S92F6-AG	600	20 / 40	33.3	1500*	1.65	2.50	1.0	400	1.0	3.0	3.9	8.5	1	E-6
PSS30S92F6-AG	600	30 / 60	47.6	1500*	1.65	2.30	1.0	400	2.0	2.1	3.0	8.5	1	E-6
PSS35S92F6-AG	600	35 / 70	66.6	1500*	1.40	1.80	1.0	400	2.0	1.5	2.8	8.5	1	E-6

* 2500V with convex heatsink

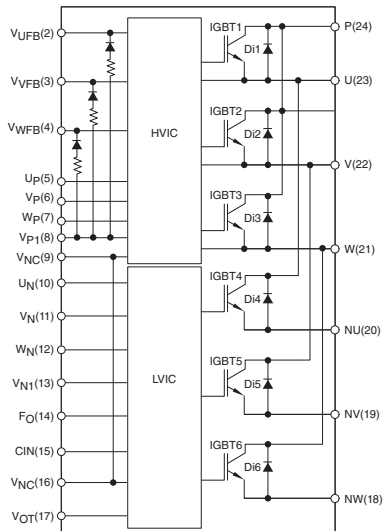

Version 4 Numbering System

PS21A79 is a DIIPM Version 4 transfer mold IPM rated at 600 Volts and 50 Amperes.

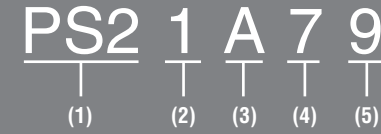

- (1) Device:
PS2 = Transfer Mold Type IPM
PS5 = DIPFPC
- (2) Voltage (V_{CES})
1 = 600V
2 = 1200V
- (3) Package Style
7 = Mini DIIPM Version 4
A = DIIPM Version 4
- (4) Factory Information
- (5) Current Rating (I_C)
1 = 3A
2 = 5A
3 = 10A
4 = 15A
5 = 20A
7 = 30A
8 = 35A
9 = 50A
A = 75A

Version 6 Numbering System

PSS15S92F6-AG is a Super Mini DIIPM Version 6 transfer mold IPM rated at 600 Volts and 15 Amperes.



- (1) Device:
PSF = Full SiC Chips
PSH = Si IGBT, SiC Diode
PSS = Si IGBT, Si Diode
PSM = Si MOSFET
- (2) Rated Current
- (3) Circuit
3-Phase (6-in-1)
C = Common Emitter
S = Open Emitter
H-Bridge (4-in-1)
B = Common Emitter
Y = Open Emitter
PFC
L = Interleaved
- (4) Package:
7 = Mini
9 = Super Mini
A = Large
- (5) Series
- (6) Built-in Functions
A = None
B = OT
C = VOT (Analog)
D = BSD
E = BSD, OT
F = BSD, VOT
- (7) V_{CES}, V_{DDS}
5 = 500V
6 = 600V
T = 1200V
- (8) Factory Options

Super Mini MOSFET DIIPM 500V Modules - Version 6 Numbering System

(Refer to device datasheets at www.pwr.com for test conditions.)

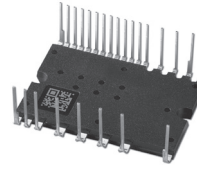

MAXIMUM RATINGS (MOSFET Inverter Sector)					ELECTRICAL CHARACTERISTICS (MOSFET Inverter Sector)					THERMAL CHARACTERISTICS MOSFET			
Type	V _{DSS} Volts	I _D /D _P Amperes	P _D Watts	V _{RMS} Isolation Volts	Typ. R _{DS(ON)} Ω	V _{SD} Volts	I _{DSS} mA	V _{DD} (PROT) Volts	t _{DEAD} (Min) usec	R _{th(j-c)} °C/W	Weight Grams	Outline Drawing Number	Page
PSM03S93E5-A	500	3 / 6	29.4	1500*	1.50	0.90	1.0	400	1.3	3.4	8.5	1	E-6
PSM05S93E5-A	500	5 / 10	44.6	1500*	0.60	0.90	1.0	400	1.3	2.8	8.5	1	E-6

* 2500V with convex heatsink

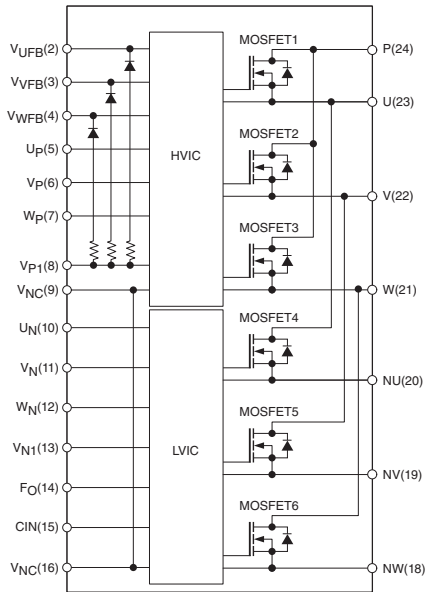

Mini DIIPM 600V Modules - Version 6 Numbering System
 (Refer to device datasheets at www.pwr.com for test conditions.)

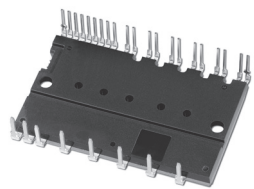

MAXIMUM RATINGS (IGBT Inverter Sector)					ELECTRICAL CHARACTERISTICS (IGBT Inverter Sector)					THERMAL CHARACTERISTICS		Weight Grams	Outline Drawing	
Type	V _{CES} Volts	I _{C/CP} Amperes	P _D Watts	V _{RMS} Isolation Volts	Typ. V _{CE(SAT)} Volts	V _{EC} Volts	I _{CES} mA	V _{CC(PROT)} Volts	t _{DEAD(Min)} usec	IGBT R _{th(j-c)} °C/W	Diode R _{th(j-c)} °C/W		Number	Page
PSS20S71F6	600	20 / 40	76.9	2500	1.40	1.50	1.0	400	1.5	1.3	3.0	21	2	E-6
PSS30S71F6	600	30 / 60	90.9	2500	1.40	1.50	1.0	400	1.5	1.1	2.8	21	2	E-6
PSS50S71F6	600	50 / 100	TBD	2500	TBD	TBD	1.0	400	1.5	TBD	TBD	21	2	E-6

DIPPFC 600V Modules - Version 4 Numbering System
 (Refer to device datasheets at www.pwr.com for test conditions.)

MAXIMUM RATINGS (MOSFET Inverter Sector)				ELECTRICAL CHARACTERISTICS (MOSFET Inverter Sector)				THERMAL CHARACTERISTICS		Weight Grams	Outline Drawing	
Type	V _{CES} Volts	I _{r(RMS)} Amperes	V _{RMS} Isolation Volts	Typ. V _{CE(SAT)} Volts	Typ. V _{EC(H)} Volts	Typ. V _{EC(L)} Volts	I _{CES} mA	IGBT R _{th(j-c)} °C/W	Diode R _{th(j-c)} °C/W		Number	Page
PS51787	600	20	2500	2.05	2.2	1.2	1.0	0.96	1.35	54	5	E-8
PS51789	600	20	2500	2.10	2.2	1.2	1.0	0.68	0.90	54	5	E-8

PSS20S71F6, PSS30S71F6, PSS50S71F6

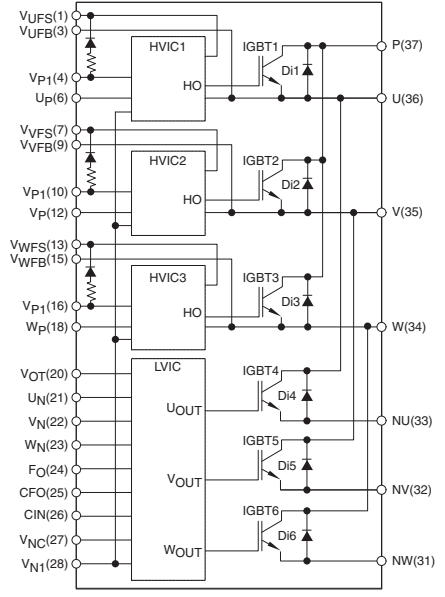

PS51787, PS51789

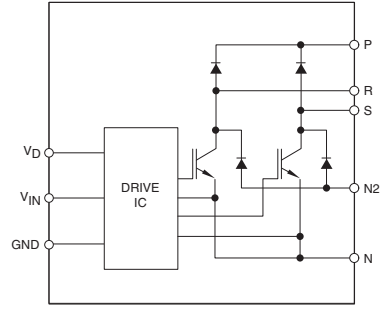

Large DIIPM 600V & 1200V Modules (Refer to device datasheets at www.pwr.com for test conditions.)

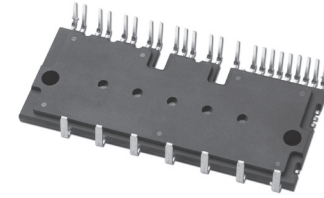

MAXIMUM RATINGS (IGBT Inverter Sector)					ELECTRICAL CHARACTERISTICS (IGBT Inverter Sector)					THERMAL CHARACTERISTICS		Weight Grams	Outline Drawing	
Type	V _{CE(S)} Volts	I _C /I _{CP} Amperes	P _D Watts	V _{RMS} Isolation Volts	Typ. V _{CE(SAT)} Volts	V _{EC} Volts	I _{CES} mA	V _{CC} (PROT) Volts	t _{DEAD} (Min) usec	IGBT R _{th(j-c)} °C/W	Diode R _{th(j-c)} °C/W		Number	Page
600V - Version 4 Numbering System														
PS21A79	600	50 / 100	142	2500	1.55	1.7	1.0	400	2.0	0.88	1.78	65	3	E-7
PS21A7A	600	75 / 150	162	2500	1.55	1.7	1.0	400	2.0	0.77	1.25	65	3	E-7
1200V - Version 6 Numbering System														
PSS05SA2FT	1200	5 / 10	TBD	2500	TBD	TBD	1.0	800	TBD	TBD	TBD	TBD	4	E-7
PSS10SA2FT	1200	10 / 20	TBD	2500	TBD	TBD	1.0	800	TBD	TBD	TBD	TBD	4	E-7
PSS15SA2FT	1200	15 / 30	TBD	2500	TBD	TBD	1.0	800	TBD	TBD	TBD	TBD	4	E-7
PSS25SA2FT	1200	25 / 50	TBD	2500	TBD	TBD	1.0	800	TBD	TBD	TBD	TBD	4	E-7
PSS35SA2FT	1200	35 / 70	TBD	2500	TBD	TBD	1.0	800	TBD	TBD	TBD	TBD	4	E-7
PSS50SA2FT	1200	50 / 100	TBD	2500	TBD	TBD	1.0	800	TBD	TBD	TBD	TBD	4	E-7

PS21A79, PS21A7A

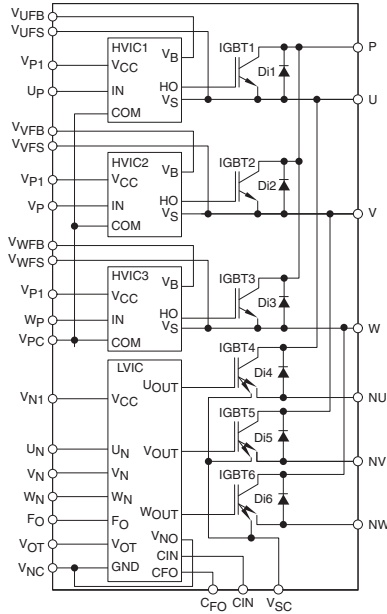

PSS05SA2FT, PSS10SA2FT, PSS15SA2FT, PSS25SA2FT, PSS35SA2FT, PSS50SA2FT

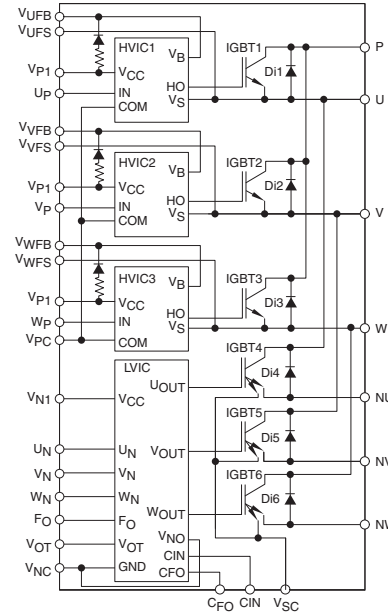

1

PSM03S93E5-A, PSM05S93E5-A,
PSS05S92F6-AG, PSS10S92F6-AG, PSS15S92F6-AG,
PSS20S92F6-AG, PSS30S92F6-AG, PSS35S92F6-AG

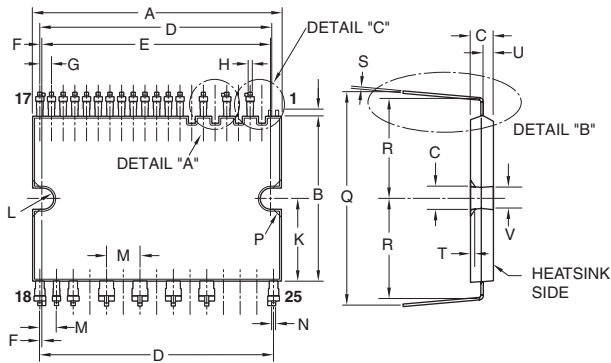

TERMINAL CODE

1-A NC(V _{NC})	13 V _{N1}
1-B NC(V _{P1})	14 F _O
2 V _{UFB}	15 C _{IN}
3 V _{VFB}	16 V _{NC} ¹
4 V _{WFB}	17 V _{OT} ²
5 U _P	18 N _W
6 V _P	19 N _V
7 V _{P1}	20 N _U
8 V _{P1}	21 W
9 V _{NC} ¹	22 V
10 U _N	23 U
11 V _N	24 P
12 W _N	25 N _C

¹ - Pin 9 & Pin 16 are connected inside the DIPIM, use either Pin 9 or Pin 16 for the ground connection and leave the other one open.

² - For MOSFET devices #17 is NC

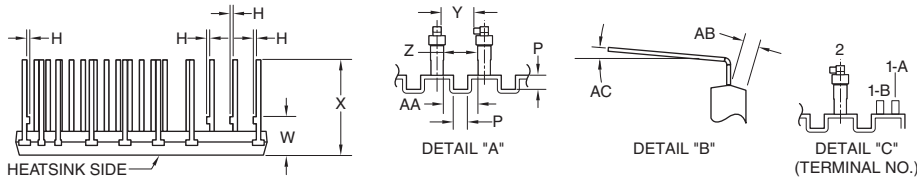

Dim.	Inches	Millimeters
A	1.50±0.02	38.0±0.5
B	0.94±0.02	24.0±0.5
C	0.14	3.5
D	1.40	35.56
E	0.07±0.008	35.0±0.2
F	0.011	0.28
G	0.07±0.008	1.778±0.2
H	0.02	0.5
J	0.04	1.0

Dim.	Inches	Millimeters
K	0.47	12.0
L	0.063 Rad.	1.6 Rad.
M	0.1±0.008	2.54±0.2
N	0.024	0.6
P	0.05	1.2
Q	1.16±0.02	29.4±0.5
R	0.57±0.02	14.4±0.5
S	0.016	0.4
T	0.031	0.8

Dim.	Inches	Millimeters
U	0.06±0.02	1.5±0.05
V	0.13	3.3
W	0.22±0.02	5.5±0.5
X	0.55±0.02	14.0±0.5
Y	0.098 Min.	2.5 Min.
Z	0.1046	2.656
AA	0.1085	2.756
AB	0.06 Min.	1.5 Min.
AC	0 ~ 5°	0 ~ 5°

2

PSS20S71F6, PSS30S71F6, PSS50S71F6

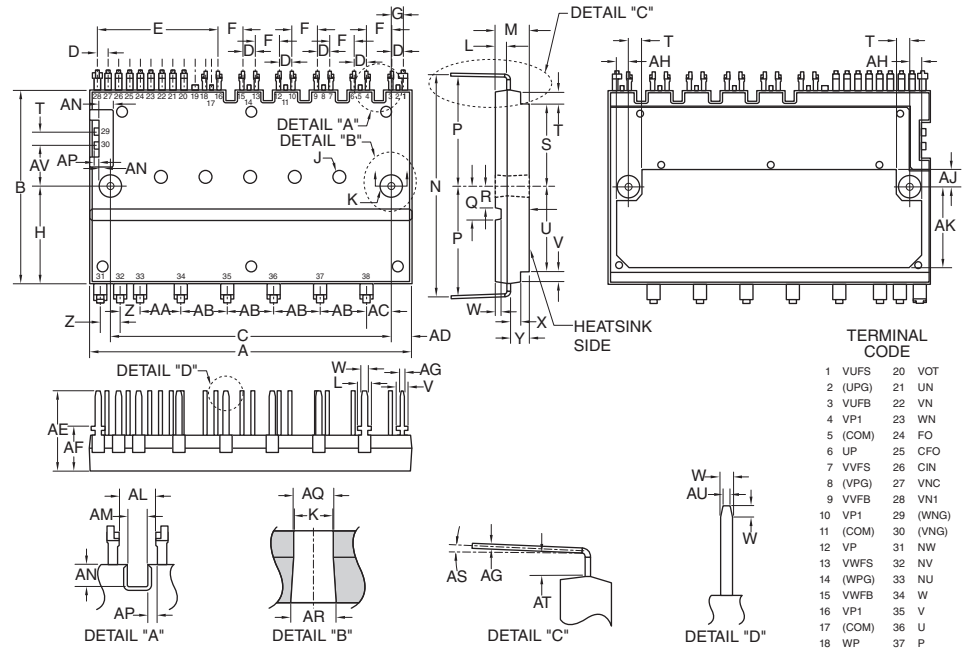

TERMINAL CODE

1 V _{UFS}	20 V _{OT}
2 (UPG)	21 U _N
3 V _{UFB}	22 V _N
4 V _{P1}	23 W _N
5 (COM)	24 F _O
6 U _P	25 C _{F_O}
7 V _{VFS}	26 C _{IN}
8 (VPG)	27 V _{NC}
9 V _{VFB}	28 V _{N1}
10 V _{P1}	29 (W _{NG})
11 (COM)	30 (V _{NG})
12 V _P	31 N _W
13 V _{VFS}	32 N _V
14 (WPG)	33 N _U
15 V _{WFB}	34 W
16 V _{P1}	35 V
17 (COM)	36 U
18 W _P	37 P
19 (UNG)	38 N _C

Dim.	Inches	Millimeters
A	2.07	52.5
B	1.22	31.0
C	1.81±0.008	46.0±0.2
D	0.07±0.008	1.78±0.2
E	0.77	19.58
F	0.17±0.008	4.32±0.2
G	0.08±0.019	2.04±0.3
H	0.61	15.5
J	0.09 Dia. x 0.1 Depth	2.2 Dia. x 2.6 Depth
K	0.13 Dia.	3.3 Dia.
L	0.08	2.0
M	0.22	5.6
N	1.41±0.02	35.9±0.5
P	0.69	17.7

Dim.	Inches	Millimeters
Q	0.216	5.5
R	0.14	3.5
S	0.503	12.78
T	0.09	2.2
U	0.53	13.5
V	0.06	1.5
W	0.04	1.0
X	0.06	1.55
Y	0.12	3.1±0.1
Z	0.13±0.019	3.3±0.3
AA	0.26±0.019	6.6±0.3
AB	0.3±0.019	7.62±0.3
AC	0.15±0.019	3.95±0.3
AD	0.13	3.25
AE	0.5	12.7

Dim.	Inches	Millimeters
AF	0.28	7.1
AG	0.02	0.5
AH	0.067	1.7
AJ	0.11	2.8
AK	0.51	13.0
AL	0.114	2.9
AM	0.063	1.6
AN	0.068	1.75
AP	0.03	0.75
AQ	0.14 Dia.	3.5 Dia.
AR	0.145 Dia.	3.7 Dia.
AS	0° ~ 5°	
AT	0.078	1.96
AU	0.023	0.6
AU	0.26	6.55

3 PS21A79, PS21A7A

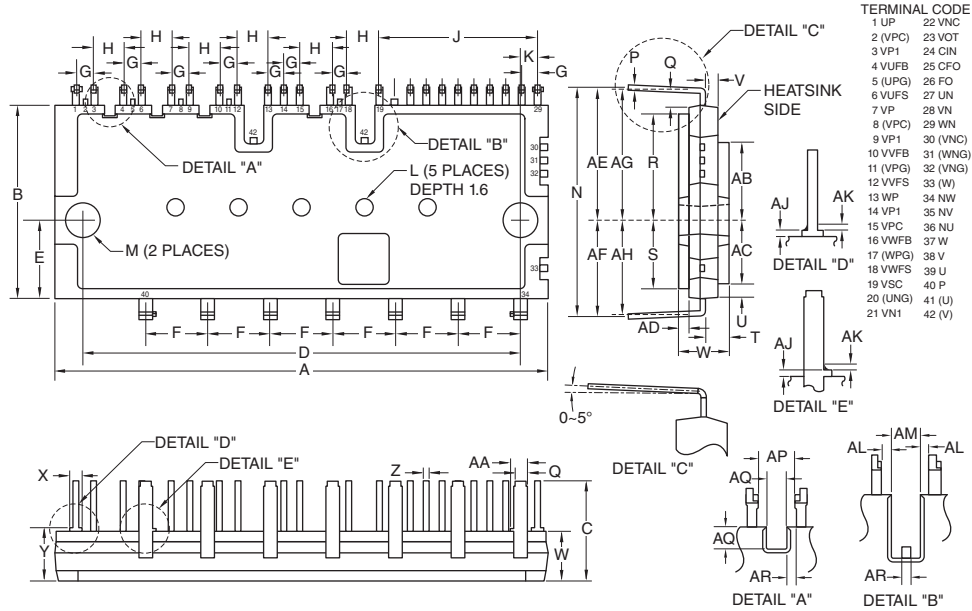

Dim.	Inches	Millimeters
A	3.11±0.02	79.0±0.5
B	1.22±0.02	31.0±0.5
C	0.63	16.0
D	2.76±0.01	70.0±0.3
E	0.5	12.7
F	0.39±0.01	10.0±0.3
G	0.1±0.01	2.54±0.3
H	0.2±0.01	5.08±0.3
J	1.0	25.4
K	0.11	2.8
L	0.12 Dia.	2.9 Dia.
M	0.18±0.01 Dia.	4.5±0.2 Dia.
N	1.42±0.02	36.2±0.5
P	0.03	0.7

Dim.	Inches	Millimeters
Q	0.08	2.0
R	0.66	16.73
S	0.44	11.13
T	0.15±0.04	3.8±1.0
U	0.082	2.1
V	0.086	2.2
W	0.31	8.0
X	0.07	1.8
Y	0.34	8.6
Z	0.03	0.8
AA	0.106	2.7
AB	0.48	12.33
AC	0.39	10.12
AD	0.068	1.75

Dim.	Inches	Millimeters
AE	0.82	20.9
AF	0.60	15.3
AG	0.81	20.64
AH	0.59	15.03
AJ	0.23	0.6
AK	0.02	0.5
AL	0.021	0.55
AM	0.11	2.9
AN	0.23	5.95
AP	0.14	3.52
AQ	0.063	1.6
AR	0.04	1.06

4 PSS05SA2FT, PSS10SA2FT, PSS15SA2FT, PSS25SA2FT, PSS35SA2FT, PSS50SA2FT

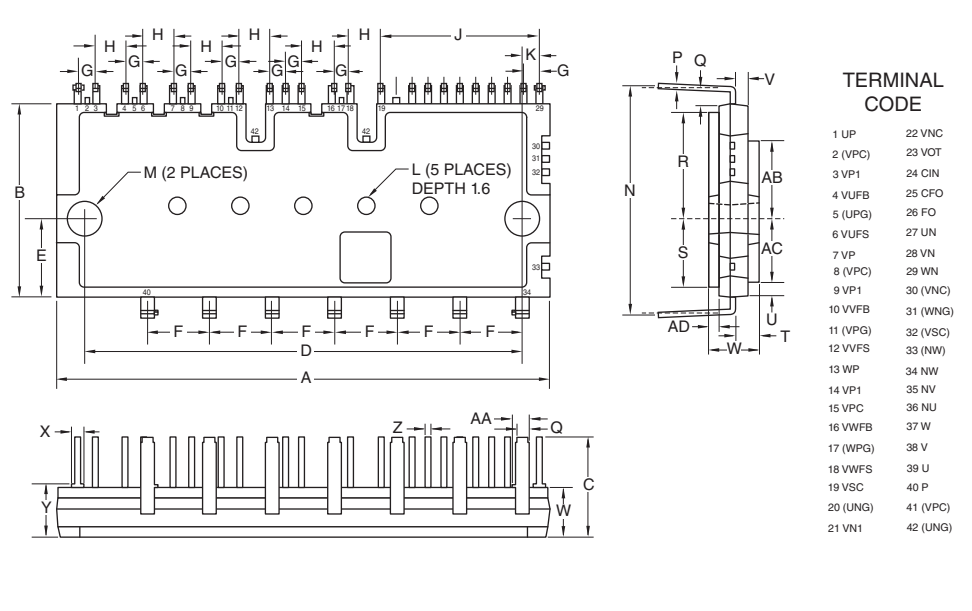

Dim.	Inches	Millimeters
A	3.11±0.02	79.0±0.5
B	1.22±0.02	31.0±0.5
C	0.63	16.0
D	2.76±0.01	70.0±0.3
E	0.5	12.7
F	0.39±0.01	10.0±0.3
G	0.1±0.01	2.54±0.3
H	0.2±0.01	5.08±0.3
J	1.0	25.4
K	0.11	2.8
L	0.12 Dia.	2.9 Dia.
M	0.18±0.01 Dia.	4.5±0.2 Dia.
N	1.42±0.02	36.2±0.5
P	0.03	0.7

Dim.	Inches	Millimeters
Q	0.08	2.0
R	0.66	16.73
S	0.44	11.13
T	0.15±0.04	3.8±1.0
U	0.082	2.1
V	0.086	2.2
W	0.31	8.0
X	0.07	1.8
Y	0.34	8.6
Z	0.03	0.8
AA	0.106	2.7
AB	0.48	12.33
AC	0.39	10.12
AD	0.068	1.75

5 PS51787, PS51789

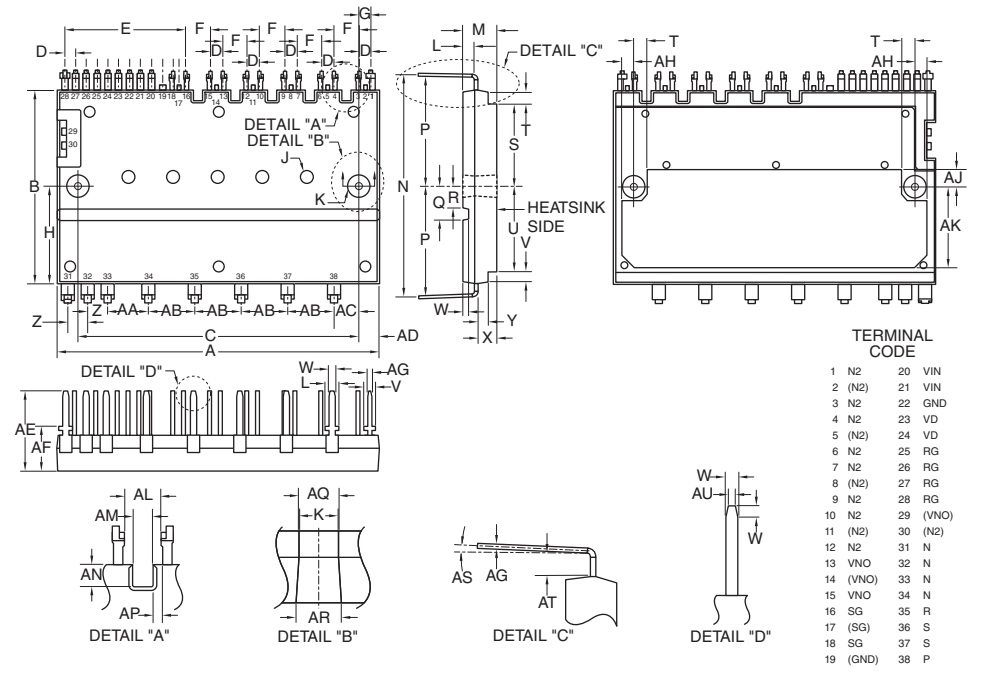

TERMINAL CODE

1	N2	20	VIN
2	(N2)	21	VIN
3	N2	22	GND
4	N2	23	VD
5	(N2)	24	VD
6	N2	25	RG
7	N2	26	RG
8	(N2)	27	RG
9	N2	28	RG
10	N2	29	(VNO)
11	(N2)	30	(N2)
12	N2	31	N
13	VNO	32	N
14	(VNO)	33	N
15	VNO	34	N
16	SG	35	R
17	(SG)	36	S
18	SG	37	S
19	(GND)	38	P

Dim.	Inches	Millimeters	Dim.	Inches	Millimeters	Dim.	Inches	Millimeters
A	2.07	52.5	Q	0.216	5.5	AF	0.28	7.1
B	1.22	31.0	R	0.14	3.5	AG	0.02	0.5
C	1.81±0.008	46.0±0.2	S	0.503	12.78	AH	0.067	1.7
D	0.07±0.008	1.78±0.2	T	0.09	2.2	AJ	0.11	2.8
E	0.77	19.58	U	0.53	13.5	AK	0.51	13.0
F	0.17±0.008	4.32±0.2	V	0.06	1.5	AL	0.114	2.9
G	0.08±0.019	2.04±0.3	W	0.04	1.0	AM	0.063	1.6
H	0.61	15.5	X	0.06	1.55	AN	0.068	1.75
J	0.09 Dia. x 0.1 Depth	2.2 Dia. x 2.6 Depth	Y	0.12	3.1±0.1	AP	0.03	0.75
K	0.13 Dia.	3.3 Dia.	Z	0.13±0.019	3.3±0.3	AQ	0.14 Dia.	3.5 Dia.
L	0.08	2.0	AA	0.26±0.019	6.6±0.3	AR	0.145 Dia.	3.7 Dia.
M	0.22	5.6	AB	0.3±0.019	7.62±0.3	AS	0° ~ 5°	
N	1.41±0.02	35.9±0.5	AC	0.15±0.019	3.95±0.3	AT	0.078	1.96
P	0.69	17.7	AD	0.13	3.25	AU	0.023	0.6
			AE	0.5	12.7			

DISCRETE THYRISTORS

Phase Control SCR / Inverter Grade SCR

Applications Include:

- Battery Chargers
- Flexible AC Transmissions
- HVDC
- Induction Heating
- Medical Equipment
- Medium Voltage Inverters
- Motor Controls
- Power Supplies
- Soft Starters
- Traction Inverters
- Transportation
- UPS
- VAR Generators
- Welding

Packages:

- Discrete Discs
- Discrete Studs

Features:

- Nickel Plating Finish
- Hermetic Encapsulation for Long-Term Reliability to 1×10^{-6} cc/He/sec

TABLE OF CONTENTS

Numbering System	F-2
Standard Leads.....	F-2
Phase Control SCRs.....	F-3
Inverter Grade SCRs.....	F-6
Outline Drawings.....	F-8

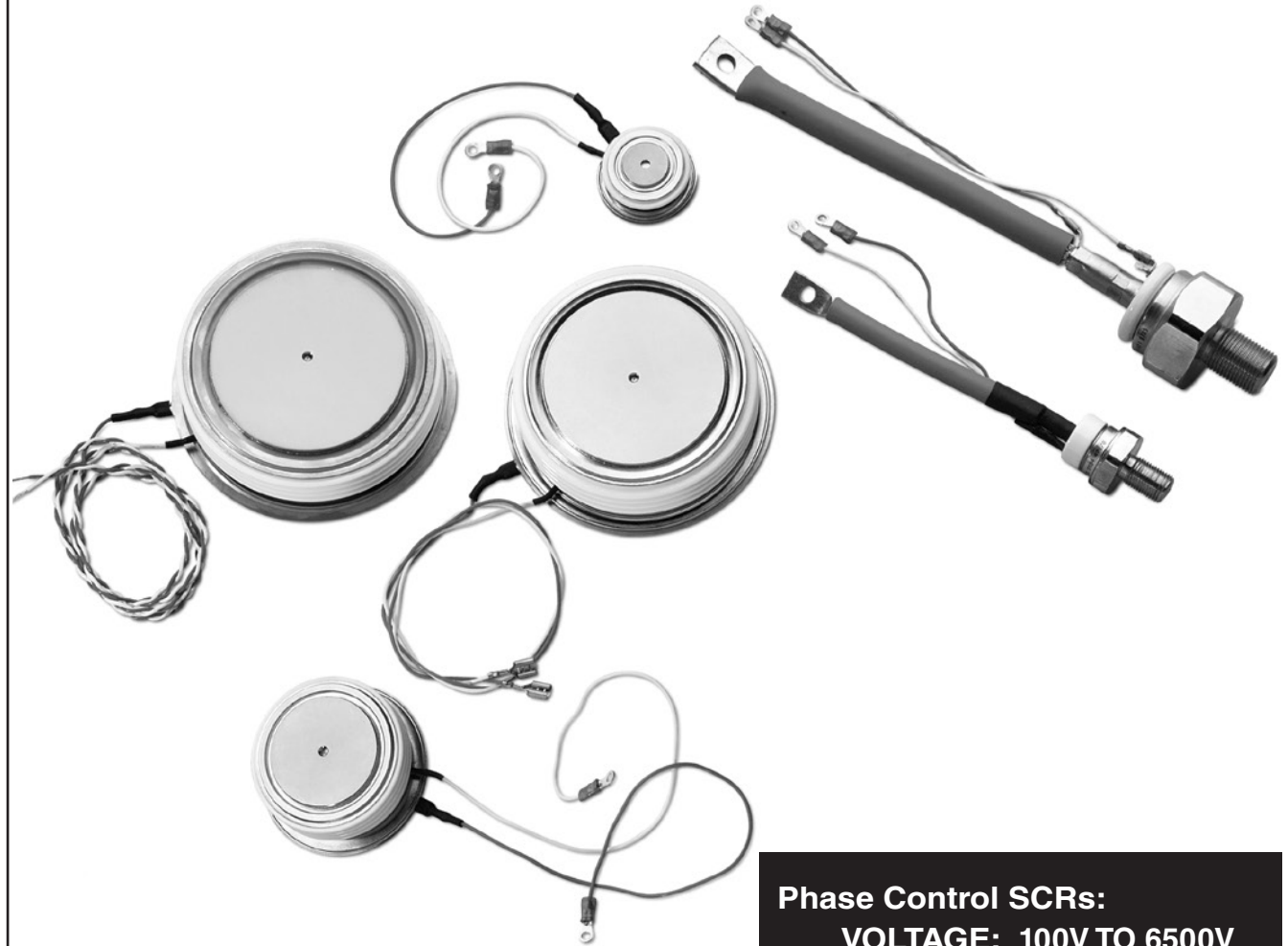

Phase Control SCRs:

VOLTAGE: 100V TO 6500V

CURRENT: 40A TO 5000A

Inverter Grade SCRs:

VOLTAGE: 200V TO 2000V

CURRENT: 40A TO 2100A

DC-DC
Converters

Gate Drivers
& IPM
Interface

Custom
Modules

IGBT
Assemblies

Assemblies

Fast Recovery
Diode Modules

Thyristor &
Diode
Modules

Discrete
Rectifiers

**Discrete
Thyristors**

DIPIPM

IPMs

MOSFET
Modules

Hybrid
& SiC
Modules

IGBTs

Numbering System

T7S0246504DN is a 650 Ampere, 2400 Volt, Phase Control SCR



- (1) Type Number
- (2) Voltage Rating (x 100)
- (3) Current Rating:
 T5 (x 1)
 T6, T7, T8 (x 10)
 T9, TA, TB, TC, TD (x 100)

(4) Turn-off Time (T_q) Codes for SCR Part Numbers

Code	Time (μsec)	Code	Time (μsec)
0	Phase Control	2	60
9	8	C	70
8	10	1	80
7	15	K	100
6	20	M	125
B	25	N	150
5	30	P	175
L	35	Q	200
4	40	R	250
3	50		

T627122064DN is a 200 Ampere, 1200 Volt, Inverter Grade SCR

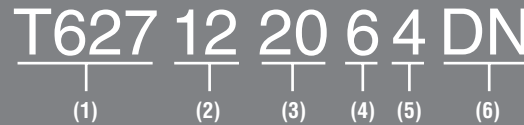

(5) Maximum Gate Current to Trigger (I_{gt}) Codes for SCR Part Numbers

Code	I _{gt} (mA)
7	70
K	75
6	80
5	100
F	120
4	150
G	180
3	200
H	250
2	300
1	500
X	Not Applicable

(6) Lead Code - Refer to Standard Lead Table

C712L is a 1000 Ampere, 2000 Volt, Inverter Grade SCR



- (1) Type Number
- (2) Voltage Code
 PB = 1200V
 PD = 1400V
 PM = 1600V
 PN = 1800V
 L = 2000V

Standard Leads

Device Type	Lead Code	Description
Disc		
Disc	DN	Gate leads: 8" with #6 ring terminals
Disc	DH	Gate leads: 12" with #6 ring terminals
Disc	HE	Gate leads: 20" with #6 ring terminals
Stud		
T5	AQ	Power Lead: 6.04" from seating plane to center of 0.266" diameter hole in terminal lug, Gate leads: 7.34" with #6 ring terminals
T6	BT	Power Lead: 7.85" from seating plane to center of 0.281" diameter hole in terminal lug, Gate leads: 7.86" with #6 ring terminals
T7	BY	Power Lead: 9.66" from seating plane to center of 0.343" diameter hole in terminal lug, Gate leads: 10.03" with #6 ring terminals (Note: High Voltage T7 studs with convoluted seal will have power lead 9.88" from seating plane to center of 0.343" diameter hole in terminal lug, Gate leads: 10.03" with #6 ring terminals)

Phase Control SCRs - Disc/Hockey Puk (Refer to device datasheets at www.pwr.com for test conditions.)

Type		V_{DRM} / V_{RRM} Volts ($V_{RSM} = V_{RRM} + 100V$)	$I_{T(av) / T_C}$ Amperes/°C (180° sin)	$I_{T(RMS)}$ Amperes (180° sin)	EUROPEAN		NORTH AMERICAN		V_{TM} / I_{TM} Volts/Amperes ($T_{j(max)}$)	V_{TO} Volts ($T_{j(max)}$)	R_T mΩ ($T_{j(max)}$)	di/dt Amperes/usec (Non-Repetitive)	T_q usec (Typical)	dV/dt Volts/usec	$R_{th(j-c)}$ °C/W	$R_{th(c-s)}$ °C/W	$T_{j(max)}$ °C	Outline Drawings		
					I_{TSM} Amperes (10ms, $T_{j(max)}$). No V_{RRM} Reapplied)	i^2t A ² sec (10ms, $T_{j(max)}$). No V_{RRM} Reapplied)	I_{TSM} Amperes (8.3ms, $T_{j(max)}$). 100% V_{RRM} Reapplied)	i^2t A ² sec (8.3ms, $T_{j(max)}$). 100% V_{RRM} Reapplied)										Number	Page	
Up to 1800V																				
T620--2004DN		200 – 1600	200 / 88	315	6,000	180,000	4,000	64,000	1.98 / 500	1.13	1.72	800	100	300	0.08	0.02	125	1	F-8	
T620--3004DN		200 – 1600	300 / 80	470	8,250	340,313	5,500	120,000	1.49 / 500	0.99	1.05	800	100	300	0.08	0.02	125	1	F-8	
T625--4004DN		200 – 1200	400 / 80	625	7,500	281,250	5,000	100,000	1.1 / 200	0.77	1.24	800	150	300	0.08	0.02	150	1	F-8	
T7H8--6504DN		200 – 1600	650 / 65	1,020	13,500	911,250	9,000	338,000	1.38 / 500	1.034	0.629	600	150	300	0.04	0.02	125	2	F-8	
T7M8--6504DN		200 – 1600	650 / 65	1,020	13,500	911,250	9,000	338,000	1.38 / 500	1.034	0.629	600	1500	300	0.04	0.02	125	3	F-8	
T7H8--7504DN		200 – 1600	750 / 62	1,180	15,750	1.2 x 10 ⁶	10,500	460,000	1.50 / 1000	0.972	0.482	600	150	300	0.04	0.02	125	2	F-8	
T7M8--7504DN		200 – 1600	750 / 62	1,180	15,750	1.2 x 10 ⁶	10,500	460,000	1.50 / 1000	0.972	0.482	600	1500	300	0.04	0.02	125	3	F-8	
T820--9004DH		200 – 1600	900 / 70	1,410	22,500	2.5 x 10 ⁶	15,000	935,000	1.20 / 1000	0.785	0.351	400	300	300	0.037	0.02	125	5	F-9	
T820--1404DH		400 – 800	1450 / 70	5,419	17,253	1.4 x 10 ⁶	12,200	620,000	1.20 / 1500 (25°C)	0.79	0.12	200	400	600	0.037	0.0085	140	5	F-9	
T9G0--1603DH		1200 – 1800	1660 / 70	2,600	27,400	3.75 x 10 ⁶	20,000	1.67 x 10 ⁶	1.25 / 1500 (25°C)	0.834	0.164	1,000	150	400	0.023	0.006	125	7	F-10	
T9S0--2003DH		1200 – 1800	2000 / 70	3,142	25,456	3.24 x 10 ⁶	18,500	1.44 x 10 ⁶	1.15 / 1500	0.755	0.226	200	400	1,000	0.015	0.0025	125	6	F-9	
TAS0--2603DH		1400 – 1800	2635 / 70	4,139	35,826	6.42 x 10 ⁶	26,174	2.85 x 10 ⁶	0.99 / 1500	0.735	0.16	300	550	800	0.01	0.003	125	8	F-10	
T9S0--2803DH		400 – 800	2850 / 70	4477	34,884	6.08 x 10 ⁶	25,400	2.71 x 10 ⁶	1.15 / 1500 (25°C)	0.722	0.0883	200	400	1000	0.015	0.0025	125	6	F-9	
TBK7--300HHE		200 – 600	3000 / 70	4,710	72,000	25.9 x 10 ⁶	48,000	9.6 x 10 ⁶	0.97 / 3000	0.692	0.087	600	400	300	0.012	0.002	125	10	F-11	
TBK5--3203DH		800 – 1600	3200 / 74	5,027	58,454	1.71 x 10 ⁶	42,700	7.60 x 10 ⁶	1.05 / 2000	0.826	0.107	200	400	1000	0.01	0.002	125	10	F-11	
T9S0--3403DH		400 – 800	3450 / 70	5,419	33,469	5.60 x 10 ⁶	24,450	2.49 x 10 ⁶	1.15 / 1500 (25°C)	0.722	0.0883	200	600	600	0.015	0.0025	125	6	F-9	
TBS7--350HHE		200 – 1600	3500 / 72	5,600	72,000	25.9 x 10 ⁶	48,000	9.6 x 10 ⁶	0.97 / 3000	0.692	0.087	600	400	300	0.010	0.002	125	11	F-11	
Up to 2400V																				
T720--3504DN		200 – 2400	350 / 77	550	10,500	551,250	7,000	205,000	1.61 / 500	1.040	1.09	600	150	300	0.06	0.02	125	5	F-9	
T720--4504DN		200 – 2400	450 / 65	700	12,600	793,800	8,400	295,000	1.25 / 300	0.93	0.90	600	150	300	0.06	0.02	125	5	F-9	
T720--5504DN		200 – 2400	550 / 65	850	15,000	1.1 x 10 ⁶	10,000	416,000	1.0 / 200	0.99	0.47	600	150	300	0.06	0.02	125	5	F-9	
T7S0--6504DN		1800 – 2400	650 / 70	1,020	13,500	911,250	9,000	338,000	1.38 / 500	1.00	0.701	600	150	300	0.035	0.02	125	4	F-9	
T7S0--7504DN		1800 – 2400	750 / 73	1,180	15,750	1.2 x 10 ⁶	10,500	460,000	1.50 / 1000	0.972	0.482	600	150	300	0.035	0.02	125	4	F-9	
T820--7504DH		200 – 2400	750 / 70	1,175	18,000	1.6 x 10 ⁶	12,000	600,000	1.52 / 1000	0.927	0.495	400	200	300	0.037	0.020	125	5	F-9	
T9G0--1003DH		200 – 2400	1000 / 82	1,590	25,500	3.2 x 10 ⁶	17,000	1.2 x 10 ⁶	1.0 / 300	0.904	0.491	600	250	1000	0.023	0.006	125	7	F-10	
T9G0--1203DH		200 – 2400	1200 / 85	1,880	40,500	8.2 x 10 ⁶	27,000	3.0 x 10 ⁶	0.97 / 1000	0.606	0.268	300	350	300	0.023	0.008	125	7	F-10	
TA20--1603DH		200 – 2200	1600 / 80	2,500	44,250	9.7 x 10 ⁶	29,500	3.63 x 10 ⁶	1.12 / 1000	0.891	0.215	400	250	300	0.015	0.007	125	9	F-10	
T9S0--1803DH		1600 – 2200	1800 / 70	2,827	19,422	1.89 x 10 ⁶	13,735	1.77 x 10 ⁶	1.38 / 1500	1.025	0.23	200	400	1000	0.015	0.0025	125	6	F-9	
TA20--1803DH		200 – 2200	1800 / 85	2,820	60,000	18.0 x 10 ⁶	40,000	6.67 x 10 ⁶	0.89 / 1000	0.719	0.167	400	250	300	0.015	0.007	125	9	F-10	
TBK7--250HHE		1200 – 2100	2500 / 72	3,925	67,500	22.7 x 10 ⁶	45,000	8.5 x 10 ⁶	1.35 / 2000	0.95	0.123	600	250	500	0.012	0.002	125	10	F-11	
TDS5--5003DH		1200 – 2000	5000 / 68	7,854	84,852	3.60 x 10 ⁷	62,000	1.6 x 10 ⁷	1.15 / 4000	0.85	0.0658	300	500	500	0.0065	0.0015	125	16	F-13	

Phase Control SCRs - Disc/Hockey Puk (Continued) (Refer to device datasheets at www.pwr.com for test conditions.)

 Type	V_{DRM} / V_{RRM} Volts ($V_{RSM} = V_{RRM} + 100V$)	$I_{T(av)TC}$ Amperes/°C (180° sin)	$I_T(RMS)$ Amperes (180° sin)	EUROPEAN		NORTH AMERICAN		V_{TM}/I_{TM} Volts/Amperes ($T_{j(max)}$)	V_{T0} Volts ($T_{j(max)}$)	R_T mΩ ($T_{j(max)}$)	di/dt Amperes/μsec (Non-Repetitive)	T_q μsec (Typical)	dV/dt Volts/μsec	$R_{th(j-c)}$ °C/W	$R_{th(c-s)}$ °C/W	$T_{j(max)}$ °C	Outline Drawings	
				I_{TSM} Amperes (10ms, $T_{j(max)}$), No V_{RRM} Reapplied)	i^2t A ² sec (10ms, $T_{j(max)}$), No V_{RRM} Reapplied)	I_{TSM} Amperes (8.3ms, $T_{j(max)}$), 100% V_{RRM} Reapplied)	i^2t A ² sec (8.3ms, $T_{j(max)}$), 100% V_{RRM} Reapplied)										Number	Page
Up to 4500V																		
T8K7--3503DH	3600 – 4500	350 / 76	550	8,250	340,313	5,500	100,000	3.50 / 1000	1.562	2.141	500	250	1000	0.040	0.020	125	5	F-9
T9K7--0802DH	3600 – 4500	800 / 79	1,250	13,500	911,250	9,000	337,500	1.79 / 1000	1.213	0.602	200	500	800	0.023	0.008	125	7	F-10
TAK7--1202DH	3600 – 4400	1200 / 82	1,700	60,000	18.0 x 10 ⁶	40,000	6.67 x 10 ⁶	1.90 / 1500	1.262	0.397	400	500	1000	0.015	0.007	125	9	F-10
TAS7--1603DH	3200 – 4400	1650 / 70	2,592	20,742	2.15 x 10 ⁶	15,154	956,845	2.00 / 1500	0.881	0.374	300	550	800	0.01	0.003	125	8	F-10
TBK7--1702HE	3600 – 4500	1650 / 70	2,590	39,000	7.6 x 10 ⁶	26,000	2.75 x 10 ⁶	1.85 / 2000	1.033	0.358	600	400	1000	0.012	0.002	125	10	F-11
TAK7--1803DH	2400 – 3200	1800 / 70	2,827	22,156	2.45 x 10 ⁶	16,180	1.09 x 10 ⁶	1.40 / 1500	0.881	0.374	300	550	800	0.15	0.007	125	9	F-10
TBKD--190HDH	3600 – 4500	1890 / 70	2,969	31,678	5.02 x 10 ⁶	23,000	2.23 x 10 ⁶	1.70 / 2000	1.13	0.275	200	600	1000	0.012	0.002	125	10	F-11
TC20--2402DH	3600 – 4400	2450 / 74	3,848	28,284	4.00 x 10 ⁶	20,664	1.78 x 10 ⁶	1.80 / 3000	0.99	0.271	300	500	400	0.009	0.003	125	13	F-12
TBS4--250HDH	3000 – 3600	2500 / 70	3,927	32,055	5.14 x 10 ⁶	23,400	2.29 x 10 ⁶	1.50 / 2000	1.026	0.233	200	600	1000	0.0085	0.002	125	11	F-11
TBSX33300HDH	3300	3000 / 70	4,712	62,750	1.97 x 10 ⁷	45,800	8.76 x 10 ⁶	1.27 / 2000	0.909	0.15	200	600	1000	0.0085	0.002	125	11	F-11
TCU4--320HDH	2400 – 2800	3200 / 70	5,027	72,000	2.59 x 10 ⁷	52,600	1.15 x 10 ⁷	1.45 / 3000	1.062	0.121	400	400	1000	0.008	0.002	125	12	F-11
TCU4--340HDH	2400 – 2800	3400 / 70	5,341	75,424	2.84 x 10 ⁷	55,000	1.27 x 10 ⁷	1.35 / 3000	0.978	0.112	400	400	1000	0.008	0.002	125	12	F-11
TDK4--3302DH	3600 – 4400	3300 / 72	5,184	47,140	1.11 x 10 ⁷	31,427	1.04 x 10 ⁷	1.60 / 3000	0.991	0.196	300	400	2000	0.005	0.001	125	15	F-12
TCS4--340HDH	1800 – 2800	3400 / 70	5,341	56,568	1.60 x 10 ⁷	37,712	1.50 x 10 ⁷	1.34 / 3000	0.915	0.14	600	400	1000	0.007	0.001	125	14	F-12
TDS4--3402DH	3000 – 3600	3475 / 70	5,459	67,200	2.26 x 10 ⁷	49,000	2.26 x 10 ⁷	1.50 / 4000	0.914	0.15	300	600	800	0.007	0.0015	125	16	F-13
Up to 6500V																		
T8K8--3203DH	6000 – 6500	325 / 75	511	4,243	9 x 10 ⁴	2,950	36,260	4.40 / 1000	1.17	3.26	200	450	1000	0.038	0.007	125	5	F-9
T9K8--0603DH	6000 – 6500	600 / 73	942	7,307	2.67 x 10 ⁵	5,040	105,840	3.70 / 1500	1.32	1.58	300	600	1000	0.023	0.006	125	7	F-10
TBK8--1203DH	6000 – 6500	1250 / 70	1,963	20,742	2.15 x 10 ⁶	14,300	852,042	2.70 / 2000	1.153	0.744	200	800	1000	0.011	0.001	125	10	F-11

Phase Control SCRs - Studs (Refer to device datasheets at www.pwr.com for test conditions.)

Type	V_{DRM} / V_{RRM} Volts ($V_{NSM} = V_{RRM} + 100V$)	$I_{T(av)}/T_C$ Amperes/°C (180° sin)	$I_T(RMS)$ Amperes (180° sin)	EUROPEAN		NORTH AMERICAN		V_{TM}/I_{TM} Volts/Amperes ($T_{j(max)}$)	V_{T0} Volts ($T_{j(max)}$)	R_T mΩ ($T_{j(max)}$)	di/dt Amperes/μsec (Non-Repetitive)	T_q μsec (Typical)	dV/dt Volts/μsec	$R_{th(j-c)}$ °C/W	$R_{th(c-s)}$ °C/W	$T_{j(max)}$ °C	Outline Drawings	
				I_{TSM} Amperes (10ms, $T_{j(max)}$), No V_{RRM} Reapplied)	i^2t A ² sec (10ms, $T_{j(max)}$), No V_{RRM} Reapplied)	I_{TSM} Amperes (8.3ms, $T_{j(max)}$), 100% V_{RRM} Reapplied)	i^2t A ² sec (8.3ms, $T_{j(max)}$), 100% V_{RRM} Reapplied)										Number	Page
Up to 1600V																		
T500--4004AQ	200 – 1600	40 / 97	63	1,800	16,200	1,200	6,000	2.02 / 100	0.91	11.85	800	100	300	0.28	0.12	125	17	F-13
T500--8004AQ	200 – 1600	80 / 75	125	2,700	36,450	1,800	13,500	1.43 / 100	0.99	3.57	800	100	300	0.28	0.12	125	17	F-13
T600--1504BT	200 – 1600	150 / 90	235	6,000	180,000	4,000	66,000	1.41 / 200	1.07	1.46	800	100	300	0.13	0.075	125	19	F-14
T650--1504BT	200 – 1600	150 / 90	235	6,000	180,000	4,000	66,000	1.41 / 200	1.07	1.46	800	100	300	0.13	0.075	125	18	F-13
T600--1804BT	200 – 1600	175 / 88	275	8,250	340,313	5,500	120,000	1.20 / 200	0.90	1.26	800	100	300	0.13	0.075	125	19	F-14
T650--1804BT	200 – 1600	175 / 88	275	8,250	340,313	5,500	120,000	1.20 / 200	0.90	1.26	800	100	300	0.13	0.075	125	18	F-13
T700--2504BY	200 – 1600	250 / 75	400	10,500	551,250	7,000	205,000	1.16 / 100	1.06	1.01	800	150	300	0.10	0.05	125	21	F-14
T750--2504BY	200 – 1600	250 / 75	400	10,500	551,250	7,000	205,000	1.16 / 100	1.06	1.01	800	150	300	0.10	0.05	125	20	F-14
Up to 2400V																		
T700--3004BY	200 – 2400	300 / 65	470	12,600	793,800	8,400	295,000	0.98 / 100	0.88	0.92	800	150	300	0.10	0.05	125	21	F-14
T750--3005BY	200 – 2400	300 / 65	470	12,600	793,800	8,400	295,000	0.98 / 100	0.88	0.92	800	150	300	0.10	0.05	125	20	F-14
T700--3504BY	200 – 2400	350 / 80	550	15,000	1.1 x 10 ⁶	10,000	416,000	0.98 / 200	0.83	0.61	800	150	300	0.10	0.05	125	21	F-14
T750--3504BY	200 – 2400	350 / 80	550	15,000	1.1 x 10 ⁶	10,000	416,000	0.98 / 200	0.83	0.61	800	150	300	0.10	0.05	125	20	F-14

Inverter Grade Disc/Hockey Puk SCRs (Refer to device datasheets at www.pwr.com for test conditions.)

Type	V_{DRM} / V_{RRM} Volts ($V_{RSM} = V_{RRM} + 100V$)	$I_{(av)}/T_C$ Amperes/°C (180° sin)	$I_{T(RMS)}$ Amperes (180° sin)	EUROPEAN		NORTH AMERICAN		V_{TM}/I_{TM} Volts/Amperes ($T_{j(max)}$)	V_{TO} Volts ($T_{j(max)}$)	R_T mΩ ($T_{j(max)}$)	di/dt Amperes/μsec (Non-Repetitive)	T_q μsec (Typical)	dV/dt Volts/μsec	$R_{th(j-c)}$ °C/W	$R_{th(c-s)}$ °C/W	$T_{j(max)}$ °C	Outline Drawings	
				I_{TSM} Amperes (10ms, $T_{j(max)}$), No V_{RRM} Reapplied)	i^2t A ² sec (10ms, $T_{j(max)}$), No V_{RRM} Reapplied)	i_{TSM} Amperes (8.3ms, $T_{j(max)}$), No V_{RRM} Reapplied)	i^2t A ² sec (8.3ms, $T_{j(max)}$), No V_{RRM} Reapplied)										Number	Page
Up to 1200V																		
T727--35*4DN	100 – 1200	350 / 70	550	10,500	551,250	7,000	205,000	1.70 / 600	1.27	0.71	800	15 – 60	300	0.06	0.02	125	5	F-9
T72H--35*4DN	100 – 1200	350 / 70	550	10,500	551,250	7,000	205,000	2.09 / 500	1.77	0.68	1200	10 – 50	300	0.06	0.02	125	5	F-9
T727--40*4DN	100 – 800	400 / 70	625	10,500	551,250	7,000	205,000	1.55 / 500	1.40	0.34	800	10 – 50	300	0.06	0.02	125	5	F-9
T72H--40*4DN	100 – 800	400 / 70	625	10,500	551,250	7,000	205,000	1.49 / 500	1.19	0.55	1200	10 – 20	300	0.06	0.02	125	5	F-9
T7SH--40*4DN	100 – 1200	400 / 70	700	12,000	720,000	8,000	267,000	2.11 / 500	1.76	0.73	1200	10 – 50	300	0.045	0.02	125	4	F-9
T727--48*4DN	100 – 800	475 / 70	750	12,000	720,000	8,000	265,000	1.37 / 500	1.35	0.44	800	15 – 50	300	0.06	0.02	125	5	F-9
T72H--48*4DN	100 – 800	475 / 70	750	12,000	720,000	8,000	265,000	1.37 / 500	1.14	0.44	1200	20 – 40	300	0.06	0.02	125	5	F-9
T7S7--50*4DN	100 – 1200	500 / 70	786	12,000	720,000	8,000	267,000	1.62 / 500	1.29	0.65	800	15 – 60	300	0.035	0.02	125	2	F-8
T7SH--50*4DN	100 – 800	500 / 70	780	12,750	812,813	8,500	301,000	1.44 / 500	1.18	0.43	1200	10 – 20	300	0.045	0.02	125	4	F-9
T7S7--55*4DN	100 – 800	550 / 70	864	12,750	812,813	8,500	301,000	1.53 / 500	1.36	0.34	800	10 – 50	300	0.035	0.02	125	2	F-8
T7SH--60*4DN	100 – 800	600 / 70	950	13,500	911,250	9,000	338,000	1.04 / 500	0.90	0.28	1200	20 – 40	300	0.045	0.02	125	4	F-9
T7S7--65*4DN	100 – 800	650 / 70	1,026	14,250	1.0 x 10 ⁶	9,500	376,000	1.36 / 500	1.15	0.40	800	10 – 50	300	0.035	0.02	125	2	F-8
Up to 1600V																		
T627--15*4DN	100 – 1600	150 / 70	235	5,250	137,813	3,500	50,000	1.64 / 100	1.41	1.80	800	10 – 50	300	0.08	0.02	125	1	F-8
T627--20*4DN	100 – 1600	200 / 70	315	6,000	180,000	4,000	65,000	1.48 / 100	1.27	1.50	800	10 – 50	300	0.08	0.02	125	1	F-8
T627--25*4DN	100 – 1600	250 / 70	400	6,750	227,813	4,500	84,000	1.38 / 100	1.22	1.12	800	10 – 50	300	0.08	0.02	125	1	F-8
T727--45*4DN	100 – 1600	450 / 70	700	12,000	720,000	8,000	265,000	1.42 / 500	1.14	0.57	800	15 – 60	300	0.06	0.02	125	5	F-9
T72H--45*4DN	100 – 1600	450 / 70	700	11,250	632,813	7,500	234,000	1.55 / 500	1.08	0.79	1200	15 – 50	300	0.06	0.02	125	5	F-9
T7SH--45*4DN	100 – 1600	450 / 70	700	12,750	812,813	8,500	301,000	1.80 / 800	1.05	0.96	1200	15 – 50	300	0.045	0.02	125	4	F-9
T7S7--60*4DN	100 – 1600	600 / 70	943	13,500	911,250	9,000	338,000	1.44 / 500	1.16	0.56	800	15 – 60	300	0.035	0.02	125	2	F-8
T82F--65*3DN	100 – 1400	650 / 70	1,000	12,750	812,813	8,500	300,000	1.75 / 1000	1.46	0.30	1000	10 – 50	400	0.037	0.02	125	5	F-9
T82F--75*3DN	100 – 1400	750 / 70	1,180	15,000	1.1 x 10 ⁶	10,000	416,000	1.52 / 1000	1.21	0.29	1200	25 – 60	400	0.037	0.02	125	5	F-9
T9GH--08*2DH	100 – 1600	800 / 70	1,250	15,000	1.1 x 10 ⁶	10,000	416,000	1.98 / 1000	1.58	0.41	1000	20 – 100	400	0.023	0.075	125	7	F-10
T9GH--09*2DH	100 – 1600	900 / 70	1,400	19,500	1.9 x 10 ⁶	13,000	700,000	1.73 / 1000	1.32	0.40	1000	20 – 100	400	0.023	0.075	125	7	F-10
T9GH--10*2DH	100 – 1600	1000 / 70	1,570	22,500	2.5 x 10 ⁶	15,000	937,000	1.70 / 1000	1.29	0.40	1000	20 – 60	400	0.023	0.075	125	7	F-10
T9GH--11*2DH	100 – 1600	1100 / 70	1,725	25,500	3.2 x 10 ⁶	17,000	1.2 x 10 ⁶	1.39 / 1000	1.12	0.25	1000	40 – 60	100	0.023	0.075	125	7	F-10
Up to 2000V																		
T7SH--36*4DN	1400 – 1800	360 / 70	565	9,000	405,000	6,000	297,000	2.19 / 500	1.81	0.81	800	40 – 60	300	0.045	0.02	125	4	F-9
T72H--42*4DN	100 – 1800	420 / 70	650	10,200	520,200	6,800	205,000	1.67 / 700	1.27	0.57	1200	15 – 100	300	0.06	0.02	125	5	F-9
T7SH--46*4DN	100 – 1800	460 / 70	720	10,200	520,200	6,800	301,000	1.47 / 500	1.22	0.58	800	15 – 70	300	0.045	0.02	125	4	F-9
C712	100 – 2000	1000 / 70	1,570	30,000	4.5 x 10 ⁶	20,000	1.6 x 10 ⁶	1.50 / 1000	1.13	0.35	800	55	500	0.023	0.075	125	7	F-10
C770	100 – 2000	2100 / 70	3,300	57,000	16.2 x 10 ⁶	38,000	6.0 x 10 ⁶	1.55 / 1000	1.27	0.26	800	80	500	0.012	0.002	125	10	F-11

Inverter Grade Stud SCRs (Refer to device datasheets at www.pwr.com for test conditions.)

Type	V_{DRM} / V_{RRM} Volts ($V_{RSM} = V_{RRM} + 100V$)	$I_{(av)} T_C$ Amperes/°C (180° sin)	$I_T(RMS)$ Amperes (180° sin)	EUROPEAN		NORTH AMERICAN		V_{TM}/T_M Volts/Amperes ($T_{j(max)}$)	V_{T0} Volts ($T_{j(max)}$)	R_T mΩ ($T_{j(max)}$)	di/dt Amperes/μsec (Non-Repetitive)	T_{θ} μsec (Typical)	dV/dt Volts/μsec	$R_{th(j-c)}$ °C/W	$R_{th(c-s)}$ °C/W	$T_{j(max)}$ °C	Outline Drawings	
				I_{TSM} Amperes (10ms, $T_{j(max)}$), No V_{RRM} Reapplied)	i^2t A ² sec (10ms, $T_{j(max)}$), No V_{RRM} Reapplied)	i_{TSM} Amperes (8.3ms, $T_{j(max)}$), No V_{RRM} Reapplied)	i^2t A ² sec (8.3ms, $T_{j(max)}$), No V_{RRM} Reapplied)										Number	Page
Up to 1200V																		
T607--13*4BT	100 – 1200	125 / 70	200	5,250	137,813	3,500	50,000	1.63 / 100	1.37	2.10	800	10 – 50	300	0.13	0.08	125	19	F-14
T707--25*4BY	100 – 1200	250 / 70	400	10,500	551,250	7,000	205,000	1.46 / 500	1.29	0.43	800	25 – 60	300	0.10	0.05	125	21	F-14
T707--28*4BY	100 – 1000	275 / 70	430	10,500	551,250	7,000	205,000	1.58 / 700	1.34	0.33	800	10 – 50	300	0.10	0.05	125	21	F-14
Up to 1600V																		
T507--40*4AQ	100 – 1600	40 / 70	63	1,500	11,250	1,000	4,000	2.36 / 100	1.00	14.81	800	10 – 50	200	0.28	0.12	125	17	F-13
T507--80*4AQ	100 – 1600	80 / 70	125	2,100	22,050	1,400	8,150	1.88 / 100	0.95	9.87	800	10 – 50	200	0.28	0.12	125	17	F-13
T607--15*4BT	100 – 1600	150 / 70	235	6,000	180,000	4,000	65,000	1.47 / 100	1.25	1.67	800	10 – 50	300	0.13	0.08	125	19	F-14
T607--18*4BT	100 – 1600	175 / 70	275	6,750	227,813	4,500	84,000	1.28 / 100	1.13	1.23	800	10 – 50	300	0.13	0.08	125	19	F-14
T707--30*4BY	100 – 1600	300 / 70	475	12,000	720,000	8,000	265,000	1.45 / 800	1.05	0.53	800	25 – 60	300	0.10	0.05	125	21	F-14
T707--33*4BY	100 – 800	325 / 70	500	12,000	720,000	8,000	265,000	1.52 / 1000	1.17	0.32	800	10 – 50	300	0.10	0.05	125	21	F-14

1 T620, T625, T627

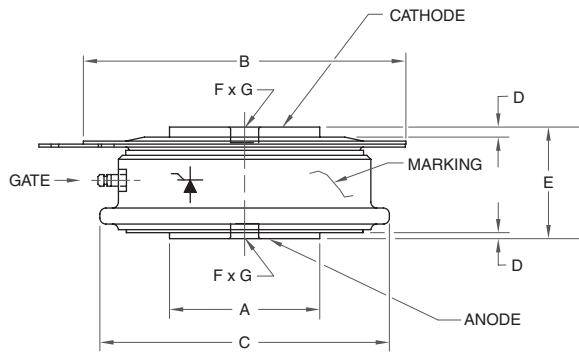

Dim.	Inches	Millimeters
A	0.752 Max.	19.1 Max.
B	1.6575 Dia.	42.1 Dia.
C	1.461 Dia.	37.1 Dia.
D	0.0197 Min.	0.5 Min.

2 T7H8, T7S7

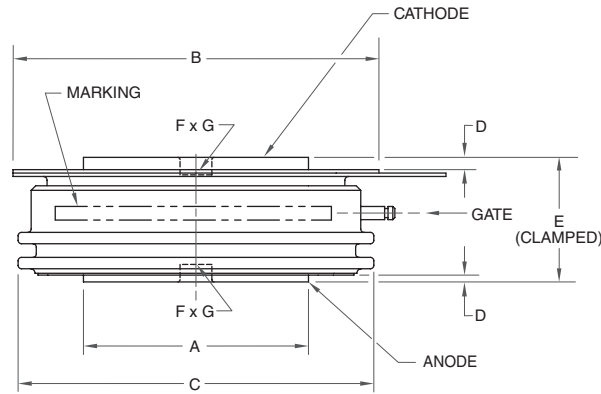

Dim.	Inches	Millimeters
A	0.996 Dia.	25.3 Dia.
B	1.6496 Dia.	41.9 Dia.
C	1.5866 Dia.	40.3 Dia.
D	0.028 Min.	0.7 Min.

3 T7M8

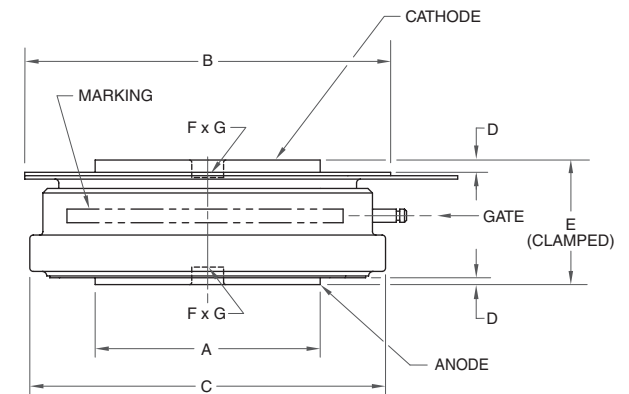

Dim.	Inches	Millimeters
A	0.996 Dia.	25.3 Dia.
B	1.6496 Dia.	41.9 Dia.
C	1.5866 Dia.	40.3 Dia.
D	0.028 Min.	0.7 Min.

Dim.	Inches	Millimeters
E	0.606 Max.	15.4 Max.
F	0.142 Dia.	3.6 Dia.
G	0.0787 Deep	2.0 Deep

4 T7SH, T7SO

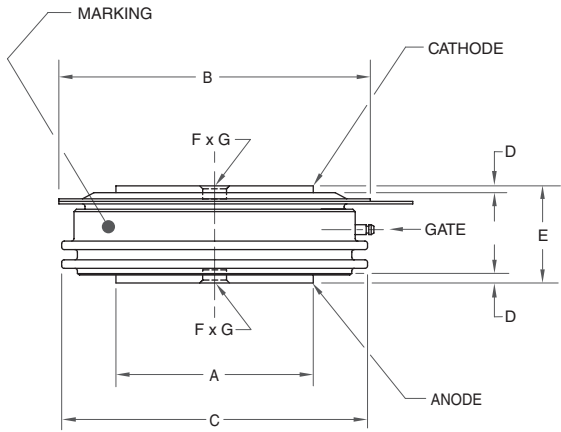

Dim.	Inches	Millimeters
A	1.180 Dia.	29.97 Dia.
B	1.90 Dia.	48.26 Dia.
C	1.850 Dia.	46.99 Dia.
D	0.025 Min.	0.64 Min.

Dim.	Inches	Millimeters
E	0.605 Max.	15.37 Max.
F	0.145 Dia.	3.68 Dia.
G	0.082 Deep	2.08 Deep

5 T720, T72H, T727, T8KC, T8K7, T82F, T820

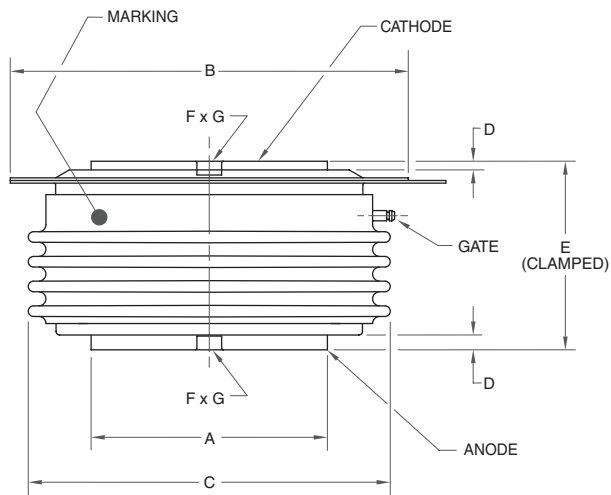

Dim.	Inches	Millimeters
A	1.34 Dia.	34.0 Dia.
B	2.28 Dia.	57.9 Dia.
C	2.05 Dia.	52.1 Dia.
D	0.03 Min.	0.76 Min.

Dim.	Inches	Millimeters
E	1.060 Max.	26.92 Max.
F	0.140 Dia.	3.56 Dia.
G	0.078 Deep	1.98 Deep

6 T9S0

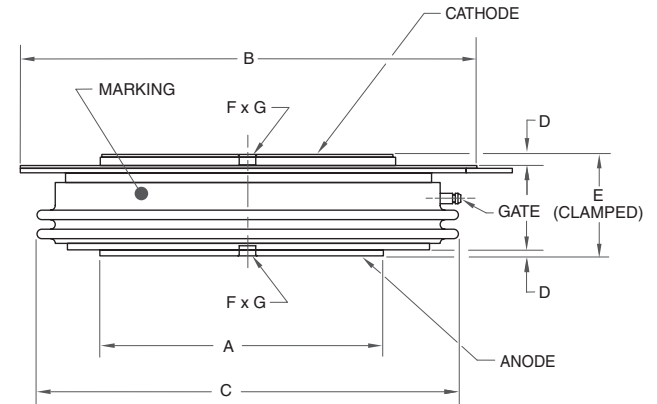

Dim.	Inches	Millimeters
A	1.85 Dia.	47.0 Dia.
B	2.91 Dia.	74.0 Dia.
C	2.64 Dia.	67.0 Dia.
D	0.028 Min.	0.7 Min.

Dim.	Inches	Millimeters
E	0.65 Max.	16.5 Max.
F	0.14 Dia.	3.5 Dia.
G	0.0787 Deep	2.0 Deep

7 C712, T9GH, T9G0, T9KC, T9K7

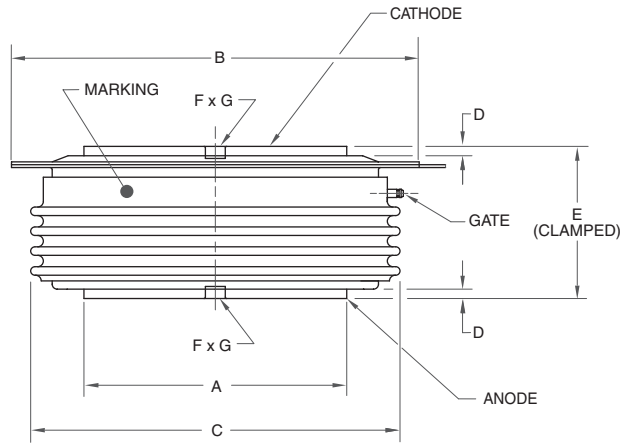

Dim.	Inches	Millimeters
A	1.858 Dia.	47.2 Dia.
B	2.902 Dia.	73.7 Dia.
C	2.642 Dia.	67.1 Dia.
D	0.028 Min.	0.7 Min.

Dim.	Inches	Millimeters
E	1.091 Max.	27.7 Max.
F	0.142 Dia.	3.6 Dia.
G	0.0787 Deep	2.0 Deep

8 TAS7, TAS0

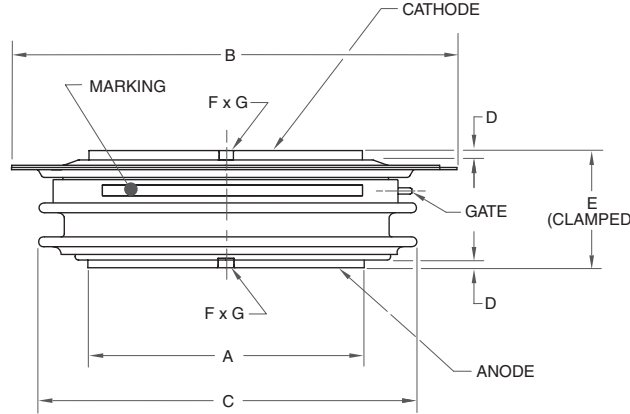

Dim.	Inches	Millimeters
A	2.480 Dia.	63.0 Dia.
B	3.937 Dia.	100.0 Dia.
C	3.551 Dia.	90.2 Dia.
D	0.028 Min.	0.7 Min.

Dim.	Inches	Millimeters
E	1.03 Max.	26.162 Max.
F	0.14 Dia.	3.556 Dia.
G	0.0787 Deep	2.0 Deep

9 TAK7, TA20

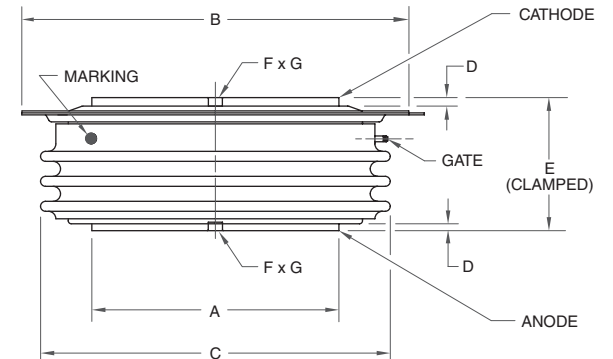

Dim.	Inches	Millimeters
A	2.480 Dia.	63.0 Dia.
B	3.937 Dia.	100.0 Dia.
C	3.551 Dia.	90.2 Dia.
D	0.028 Min.	0.7 Min.

Dim.	Inches	Millimeters
E	1.362 Max.	34.6 Max.
F	0.142 Dia.	3.6 Dia.
G	0.0787 Deep	2.0 Deep

10 C770, TBKC, TBKD, TBK5, TBK7

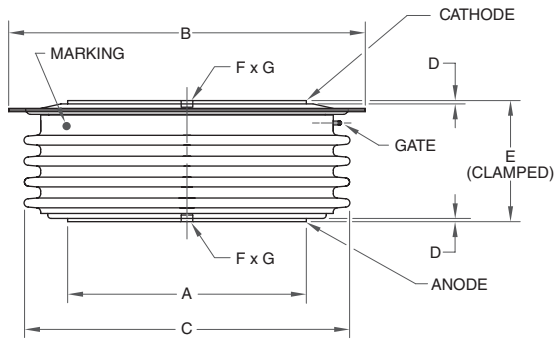

Dim.	Inches	Millimeters
A	2.882 Dia.	73.2 Dia.
B	4.36 Dia.	110.7 Dia.
C	3.961 Dia.	100.6 Dia.
D	0.028 Min.	0.7 Min.

Dim.	Inches	Millimeters
E	1.5 Max.	38.1 Max.
F	0.142 Dia.	3.6 Dia.
G	0.0787 Deep	2.0 Deep

11 TBS4, TBS7, TBSX

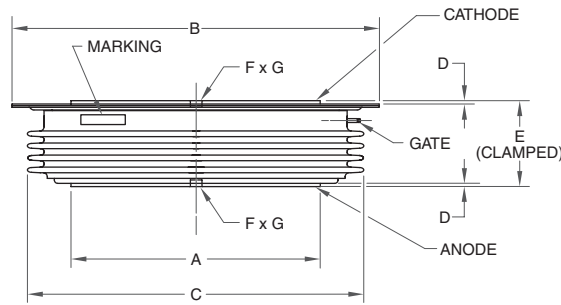

Dim.	Inches	Millimeters
A	2.88 Dia.	73.2 Dia.
B	4.36 Dia.	110.7 Dia.
C	3.95 Dia.	100.3 Dia.
D	0.03 Min.	0.76 Min.

Dim.	Inches	Millimeters
E	1.05 Max.	26.67 Max.
F	0.14 Dia.	3.56 Dia.
G	0.08 Deep	2.03 Deep

12 TCU4

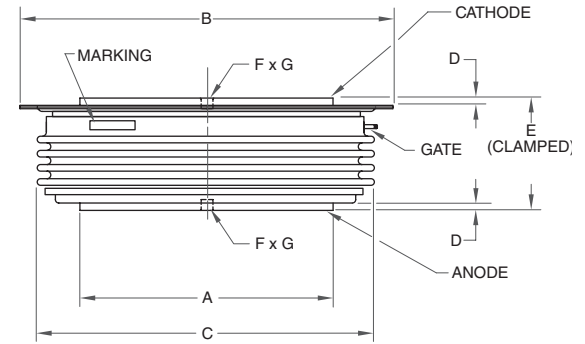

Dim.	Inches	Millimeters
A	3.11 Dia.	84.1 Dia.
B	4.72 Dia.	120.0 Dia.
C	4.37 Dia.	111.0 Dia.
D	0.028 Min.	0.7 Min.

Dim.	Inches	Millimeters
E	1.03 Max.	26.2 Max.
F	0.142 Dia.	3.6 Dia.
G	0.0787 Deep	2.0 Deep

13 TC20

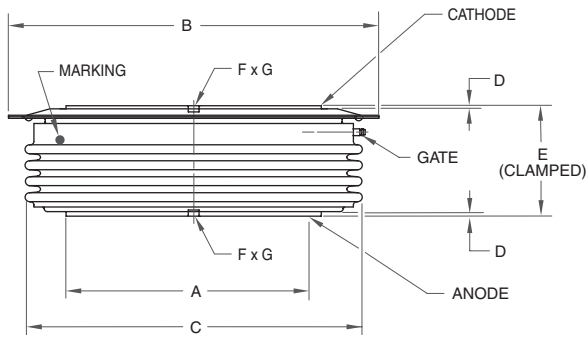

Dim.	Inches	Millimeters
A	3.11 Dia.	84.1 Dia.
B	4.8898 Dia.	124.2 Dia.
C	4.37 Dia.	111.0 Dia.
D	0.028 Min.	0.7 Min.

Dim.	Inches	Millimeters
E	1.5 Max.	38.1 Max.
F	0.142 Dia.	3.6 Dia.
G	0.0787 Deep	2.0 Deep

14 TCS4

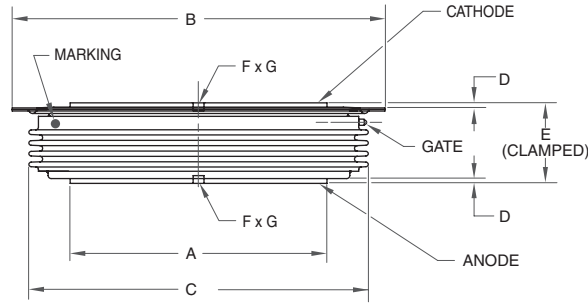

Dim.	Inches	Millimeters
A	3.311 Dia.	84.1 Dia.
B	4.889 Dia.	124.2 Dia.
C	4.370 Dia.	111.0 Dia.
D	0.028 Min.	0.7 Min.

Dim.	Inches	Millimeters
E	1.059 Max.	26.9 Max.
F	0.142 Dia.	3.6 Dia.
G	0.0787 Deep	2.0 Deep

15 TDK4

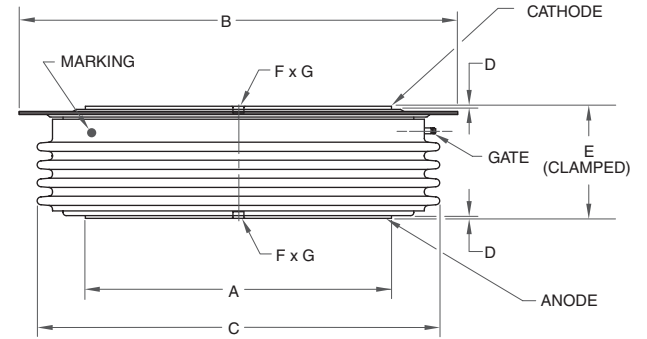

Dim.	Inches	Millimeters
A	3.913 Dia.	99.4 Dia.
B	5.661 Dia.	143.8 Dia.
C	5.181 Dia.	131.6 Dia.
D	0.028 Min.	0.7 Min.

Dim.	Inches	Millimeters
E	1.5 Max.	38.1 Max.
F	0.142 Dia.	3.6 Dia.
G	0.0787 Deep	2.0 Deep

16 TDS4, TDS5

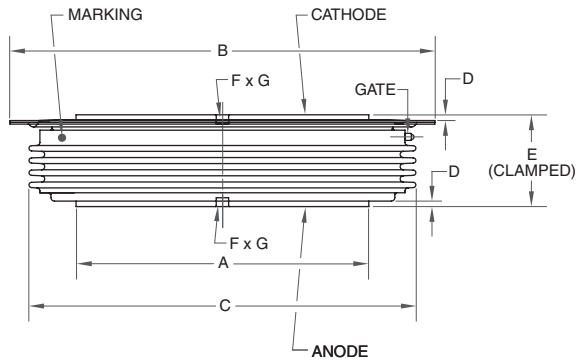

Dim.	Inches	Millimeters
A	3.913 Dia.	99.4 Dia.
B	5.661 Dia.	143.8 Dia.
C	5.181 Dia.	131.6 Dia.
D	0.028 Min.	0.7 Min.

Dim.	Inches	Millimeters
E	1.059 Max.	26.9 Max.
F	0.142 Dia.	3.6 Dia.
G	0.0787 Deep	2.0 Deep

17 T500, T507

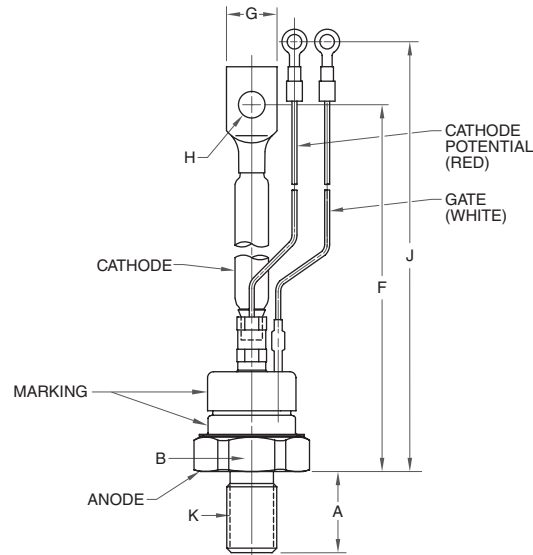

Dim.	Inches	Millimeters
A	0.815 Max.	20.7 Max.
B	1.059 Max.	26.9 Max.
F	6.240 Max.	158.5 Max.

Dim.	Inches	Millimeters
G	0.512 Max.	13.0 Max.
H	0.268 Dia.	6.8 Dia.
J	7.559 Max.	192.0 Max.
K	0.500-20 UNF-2A Thread	

18 T650

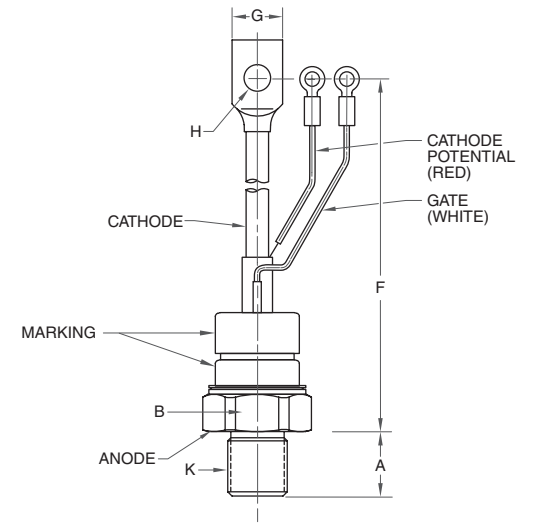

Dim.	Inches	Millimeters
A	0.822 Max.	20.88 Max.
B	1.248 Max.	31.78 Max.
F	8.03 Max.	203.96 Max.

Dim.	Inches	Millimeters
G	0.63 Max.	16.0 Max.
H	0.281 Dia.	7.14 Dia.
K		M20 x 1.5

19 T600, T607

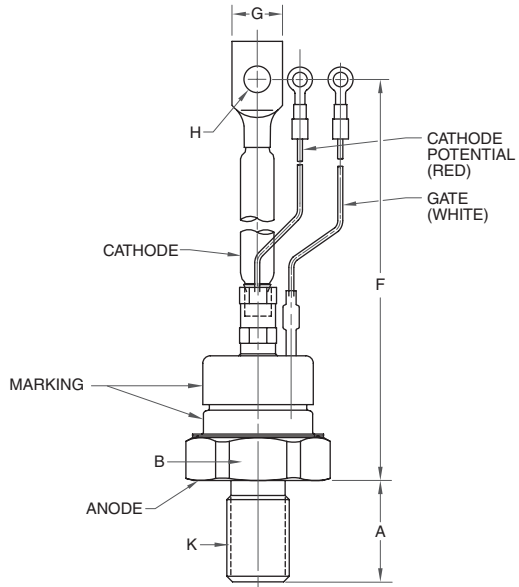

Dim.	Inches	Millimeters
A	1.063 Max.	27.0 Max.
B	1.252 Max.	31.8 Max.
	(Across Flats)	
F	8.032 Max.	204.0 Max.

Dim.	Inches	Millimeters
G	0.63 Max.	16.0 Max.
H	0.2795 Dia.	7.1 Dia.
K	0.75-16 UNF-2A Thread	

20 T750

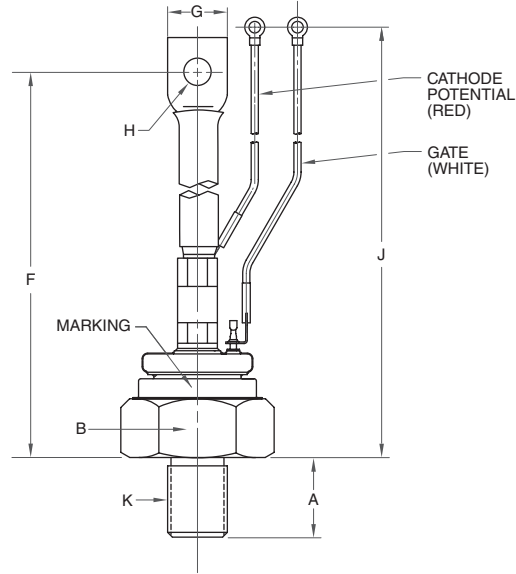

Dim.	Inches	Millimeters
A	1.08 Max.	27.4 Max.
B	1.748 Max.	44.4 Max.
	(Across Flats)	
F	9.78 Max.	248.4 Max.

Dim.	Inches	Millimeters
G	0.847 Max.	21.5 Max.
H	0.355 Dia.	9.0 Dia.
J	10.18 Max.	258.5 Max.
K	M24 x 1.5	

21 T700, T707

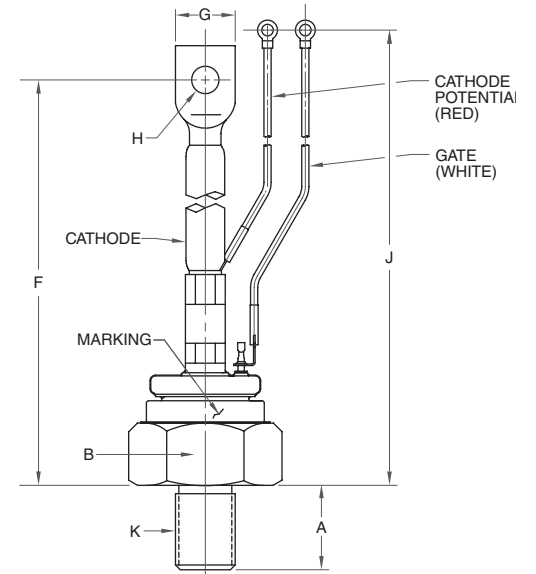

Dim.	Inches	Millimeters
A	1.083 Max.	27.5 Max.
B	1.750 Max.	44.45 Max.
	(Across Flats)	
F	9.784 Max.	248.5 Max.

Dim.	Inches	Millimeters
G	0.756 Max.	19.2 Max.
H	0.343 Dia.	8.7 Dia.
J	10.181 Max.	258.6 Max.
K	0.750-16 UNF-2A Thread	

DISCRETE RECTIFIERS

General Purpose Rectifiers

Applications Include:

- Battery Chargers
- Induction Heating/Melting
- Motor Controls
- Power Supplies
- Transportation
- Welding

Fast Recovery Rectifiers

Applications Include:

- Induction Heating
- Medical Equipment
- Motor Controls
- Transportation
- Welding

Packages:

- Discrete Discs
- Discrete Studs

Features:

- Nickel Plating Finish
- Hermetic Encapsulation for Long-Term Reliability to 1×10^{-6} cc/He/sec

TABLE OF CONTENTS

Numbering System	G-2
General Purpose Disc/Hockey Puk Diodes	G-3
General Purpose Welding Diodes	G-4
General Purpose Stud Diodes	G-5
Fast Recovery Diodes	G-6
Outline Drawings	G-7



General Purpose:

VOLTAGE: 100V TO 6500V
CURRENT: 100A TO 12,000A

Fast Recovery:

VOLTAGE: 200V TO 3600V
CURRENT: 125A TO 1500A

Numbering System

R5001210XXWA is a 100 Ampere, 1200 Volt,
General Purpose Diode (STUD)

R500 12 10 XX WA

(1) (2) (3) (4) (5)

R6031225HSYA is a 250 Ampere, 1200 Volt,
Fast Recovery Diode (STUD)

R603 12 25 HS YA

(1) (2) (3) (4) (5)

R6201250XXOO is a 500 Ampere, 1200 Volt,
General Purpose Diode (DISC)

R620 12 50 XX OO

(1) (2) (3) (4) (5)

R6221240HSOO is a 400 Ampere, 1200 Volt,
Fast Recovery Diode (DISC)

R622 12 40 HS OO

(1) (2) (3) (4) (5)

(1) Type Number	(4) Reverse Recovery Time				(5) Lead Code		
(2) Voltage Rating (x 100)	Code	Time (μsec)	Code	Time (μsec)	Device	Code	Description
(3) Current Rating: R5, R6 (x 10) R7, R8, R9, RA, RB (x 100)	XX	Standard Recovery	LS	0.7	R50* Stud	WA	Power Lead: 4.48" from seating plane to center of 0.281" diameter hole in terminal lug
	AS	5.0	MS	0.6			
	BS	4.0	NS	0.2	R60* Stud	YA	Power Lead: 5.44" from seating plane to center of 0.343" diameter hole in terminal lug
	CS	3.0	OS	4.5			
	DS	2.5	PS	0.5			
	ES	2.0	QS	0.4			
	FS	1.5	RS	0.3	R70* Stud	UA	Power Lead: 9.66" from seating plane to center of 0.343" diameter hole in terminal lug (Note: High voltage R7 studs with convoluted seal will be 9.96" from seating plane to center of 0.343" diameter hole in terminal lug)
	GS	1.25	TS	3.5			
	HS	1.0	US	2.75			
	IS	5.5	VS	2.25			
	JS	0.9	ZS	10.0			
	KS	0.8					

General Purpose Disc/Hockey Puk Diodes (Refer to device datasheets at www.pwr.com for test conditions.)

Type	 V_{RRM} Volts ($V_{RMS} = V_{RRM} + 100V$) $I_{F(av)/T_C}$ Amperes/°C (180° sin) $I_{F(RMS)}$ Amperes (180° sin)			EUROPEAN		NORTH AMERICAN		V_{FM}/I_{FM} Volts/Amperes ($T_j(max)$)	V_{TO} Volts ($T_j(max)$)	R_T mΩ ($T_j(max)$)	$R_{th(j-c)}$ °C/W	$R_{th(c-s)}$ °C/W	$T_j(max)$ °C	Outline Drawings	
				I_{FSM} Amperes (10ms, $T_j(max)$, No V_{RRM} Reapplied)	I^2t A ² sec (10ms, $T_j(max)$, No V_{RRM} Reapplied)	I_{FSM} Amperes (8.3ms, $T_j(max)$, 100% V_{RRM} Reapplied)	I^2t A ² sec (8.3ms, $T_j(max)$, 100% V_{RRM} Reapplied)							Number	Page
Up to 1200V															
RA20--48XX	200 – 1200	4800 / 98	7,535	73,500	27.0 x 10 ⁶	49,000	10.0 x 10 ⁶	0.71 / 1000	0.65128	0.06315	0.013	0.001	190	7	G-9
RBS8--70XX	200 – 600	7000 / 79	11,000	90,000	40.5 x 10 ⁶	60,000	1.5 x 10 ⁶	0.70 / 1000	0.64564	0.04421	0.0095	0.002	175	9	G-9
RDS8--10XX	200 – 1200	10,000 / 90	15,708	111,000	5.13 x 10 ⁷	120,000	6.00 x 10 ⁷	0.75 / 4000	0.642	2.28 x 10 ⁻⁴	0.0075	0.0015	175	12	G-10
Up to 2000V															
R7S0--08XX	200 – 1600	800 / 121	1,250	12,750	812,813	8,500	301,000	1.95 / 2000	0.91169	0.51788	0.035	0.02	175	2	G-7
R720--12XX	200 – 1600	1200 / 106	1,885	18,750	1.7 x 10 ⁶	12,500	650,700	0.91 / 1000	0.68	0.24	0.055	0.02	175 – 200	4	G-8
R7S0--12XX	200 – 1600	1200 / 86	1,875	13,500	911,250	9,000	337,500	1.25 / 2000	0.831	0.441	0.035	0.02	175	2	G-7
R7S0--16XX	200 – 1600	1600 / 98	2,500	21,000	2.2 x 10 ⁶	14,000	816,700	1.2 / 2000	0.62955	0.2929	0.035	0.02	200	2	G-7
R9G0--22XX	200 – 1600	2200 / 134	3,455	45,000	10.1 x 10 ⁶	30,000	3.7 x 10 ⁶	0.97 / 2000	0.79109	0.08773	0.020	0.0075	150	5	G-8
R9S0--30XX	600 – 1600	3000 / 115	4,710	45,000	10.1 x 10 ⁶	30,000	3.7 x 10 ⁶	1.10 / 1500	0.912	0.089	0.0145	0.006	175	6	G-8
RBK8--63XX	1200 – 1600	6300 / 100	9896	115,900	6.72 x 10 ⁷	84,600	2.99 x 10 ⁷	0.85 / 4000	0.688	0.0362	0.0115	0.002	190	10	G-10
RBS8--72XX	1200 – 1600	7200 / 84	11,310	115,900	6.72 x 10 ⁷	84,600	2.99 x 10 ⁷	0.90 / 4000	0.704	0.0479	0.0095	0.002	190	9	G-9
RCS8--80XX	200 – 1400	8000	12,566	TBD	TBD	TBD	TBD	TBD	TBD	TBD	TBD	TBD	175	11	G-10
Up to 2600V															
R620--30XX	200 – 2400	300 / 142	470	8,250	340,313	5,500	125,000	1.33 / 500	0.92	0.88	0.095	0.02	150 – 190	1	G-7
R620--40XX	200 – 2400	400 / 128	625	9,000	405,000	6,000	150,000	1.25 / 500	0.89	0.74	0.095	0.02	150 – 190	1	G-7
R620--50XX	200 – 2400	500 / 114	785	9,750	475,313	6,500	175,000	1.17 / 500	0.85	0.63	0.095	0.02	150 – 190	1	G-7
R7S0--08XX	1800 – 2400	800 / 121	1,250	12,750	812,813	8,500	301,000	1.95 / 2000	0.91169	0.51788	0.035	0.02	175	3	G-7
R720--09XX	200 – 2600	900 / 110	1,415	12,750	812,813	8,500	301,000	1.26 / 1000	0.84	0.42	0.055	0.02	150 – 200	4	G-8
R7S0--12XX	1800 – 2400	1200 / 86	1,875	13,500	911,250	9,000	337,500	1.25 / 2000	0.38717	0.4301	0.035	0.02	175	3	G-7
R820--16XX	200 – 2600	1600 / 82	2,513	12,950	6.99 x 10 ⁵	14,000	8.17 x 10 ⁵	1.06 / 1500	0.68	0.25	0.035	0.015	175	4	G-8
R9G0--18XX	200 – 2400	1800 / 110	2,825	32,250	5.2 x 10 ⁶	21,500	1.9 x 10 ⁶	1.25 / 2000	0.81366	0.2242	0.02	0.008	175	5	G-8
RA20--36XX	200 – 2400	3600 / 100	5,650	60,000	18.0 x 10 ⁶	40,000	6.67 x 10 ⁶	0.79 / 1000	0.66324	0.1134	0.013	0.007	175	7	G-9
RBK8--50XX	1800 – 2400	5000 / 90	7854	91,500	3.49 x 10 ⁷	66,800	1.86 x 10 ⁷	0.95 / 4000	0.661	0.0659	0.0115	0.002	175	10	G-10
RAS8--54XX	1600 – 2400	5450 / 90	8561	115,000	6.61 x 10 ⁷	84,000	2.94 x 10 ⁷	1.15 / 3000 ($T_j = 25°C$)	0.734	0.0665	0.011	0.002	175	8	G-9
RBS8--56XX	1800 – 2400	5680 / 90	8922	103,700	4.48 x 10 ⁷	75,700	2.39 x 10 ⁷	0.95 / 4000	0.661	0.0659	0.0095	0.002	175	9	G-9
RDS8--80XX	200 – 2500	8000 / 90	12,566	150,000	3.57 x 10 ⁷	100,000	4.17 x 10 ⁷	0.82 / 4000	0.654	3.82 x 10 ⁻²	0.007	0.001	175	12	G-10
Up to 3200V															
RBK8--40XX	200 – 3200	4000 / 82	6,280	75,000	28.1 x 10 ⁶	50,000	10.4 x 10 ⁶	0.78 / 1000	0.69989	0.09373	0.0115	0.002	160	10	G-10
RBS8--45XX	2200 – 3200	4500 / 94	7069	83,250	3.47 x 10 ⁷	60,800	1.54 x 10 ⁷	1.00 / 2000	0.786	0.0997	0.0095	0.002	175	9	G-9
RDK8--85XX	2400 – 3000	8500 / 90	13,352	92,500	4.28 x 10 ⁷	67,500	1.90 x 10 ⁷	0.82 / 4000	0.762	5.28 x 10 ⁻²	0.0063	0.001	160	13	G-11
RDS8--90XX	1400 – 3000	9000	14,137	TBD	TBD	TBD	TBD	TBD	TBD	TBD	0.0075	0.0015	175	12	G-10

General Purpose Disc/Hockey Puk Diodes (Refer to device datasheets at www.pwr.com for test conditions.)

Type	 V_{RRM} Volts ($V_{RMS} = V_{RRM} + 100V$)	$I_{F(av)/TC}$ Amperes/°C (180° sin)	$I_{F(RMS)}$ Amperes (180° sin)	EUROPEAN		NORTH AMERICAN		V_{FM}/I_{FM} Volts/Amperes ($T_j(max)$)	V_{TO} Volts ($T_j(max)$)	R_T mΩ ($T_j(max)$)	$R_{th(j-c)}$ °C/W	$R_{th(c-s)}$ °C/W	$T_{j(max)}$ °C	Outline Drawings		
				I_{FSM} Amperes (10ms, $T_{j(max)}$, No V_{RRM} Reapplied)	I^2t A ² sec (10ms, $T_{j(max)}$, No V_{RRM} Reapplied)	I_{FSM} Amperes (8.3ms, $T_{j(max)}$, 100% V_{RRM} Reapplied)	I^2t A ² sec (8.3ms, $T_{j(max)}$, 100% V_{RRM} Reapplied)							Number	Page	
Up to 6500V																
R720--06XX	200 – 4400	600 / 136	945	10,500	551,250	7,000	204,000	1.54 / 1000	0.92	0.61	0.055	0.02	150 – 200	4	G-8	
R8K8--06XX	6000 – 6500	600 / 100	942	7,300	2.66×10^5	5,300	1.19×10^5	1.80 / 800 ($T_j = 25^\circ C$)	0.77	1.08	0.035	0.015	150	4	G-8	
R820--07XX	4400 – 5200	690 / 100	1,084	6,938	2.41×10^5	7,500	2.34×10^5	1.94 / 1500	1.0	0.62	0.035	0.015	150	4	G-8	
R9G0--12XX	200 – 5400	1200 / 102	1,880	24,000	2.8×10^6	16,000	1.1×10^6	1.4 / 1000	1.07197	0.32357	0.020	0.008	150	5	G-8	
R9G0--14XX	6000 – 6500	1360 / 80	2,136	15,250	1.6×10^6	12,500	6.51×10^6	1.61 / 1500	0.793	0.521	0.20	0.0006	150	5	G-8	
RA20--20XX	200 – 5400	2000 / 99	3,140	36,000	6.4×10^6	24,000	2.4×10^6	1.39 / 2000	0.96347	0.20721	0.013	0.007	150	7	G-9	
RA20--25XX	200 – 4200	2500 / 100	3,920	42,000	8.8×10^6	28,000	3.2×10^6	0.87 / 1000	0.74116	0.1320	0.013	0.001	150	7	G-9	
RBK8--25XX	5600 – 6500	2500 / 85	3927	61,000	1.86×10^7	44,500	8.28×10^6	1.55 / 3000 ($T_j = 25^\circ C$)	0.79	0.238	0.0115	0.002	150	10	G-10	
RBT8--28XX	5600 – 6500	2850 / 85	4477	61,000	1.86×10^7	44,500	8.28×10^6	1.55 / 3000	0.79	0.238	0.0095	0.002	150	9	G-9	
RDK8--40XX	6000 – 6500	4000 / 68	6,283	55,000	1.28×10^7	60,000	1.50×10^7	1.65 / 4000	1.13	0.117×10^{-4}	0.0075	0.001	150	13	G-11	

General Purpose Welding Diodes (Refer to device datasheets at www.pwr.com for test conditions.)

Type	 V_{RRM} Volts ($V_{RMS} = V_{RRM} + 100V$)	$I_{F(av)/TC}$ Amperes/°C (180° sin)	$I_{F(RMS)}$ Amperes (180° sin)	EUROPEAN		NORTH AMERICAN		V_{FM}/I_{FM} Volts/Amperes ($T_j(max)$ @25°C)	V_{TO} Volts ($T_j(max)$)	R_T mΩ ($T_j(max)$)	$R_{th(j-c)}$ °C/W	$R_{th(c-s)}$ °C/W	$T_{j(max)}$ °C	Outline Drawings	
				I_{FSM} Amperes (10ms, $T_{j(max)}$, No V_{RRM} Reapplied)	I^2t A ² sec (10ms, $T_{j(max)}$, No V_{RRM} Reapplied)	I_{FSM} Amperes (8.3ms, $T_{j(max)}$, 100% V_{RRM} Reapplied)	I^2t A ² sec (8.3ms, $T_{j(max)}$, 100% V_{RRM} Reapplied)							Number	Page
R9XSMD0448XX	400	4800 / 84	7540	33,600	5.64×10^6	35,000	5.10×10^6	1.20 / 4000	0.701	0.053	0.009	0.005	175	20	G-13
R9XSMD0463XX	400	6300 / 40	9,896	33,600	5.64×10^6	35,000	5.10×10^6	1.10 / 4000	0.701	0.053	0.009	0.005	175	20	G-13
R9XSMD0475XX	400	7450 / 40	11,702	42,000	8.82×10^6	43,700	7.96×10^6	1.05 / 4000	0.720	0.0308	0.009	0.005	175	21	G-13
RAXMHC0412XX	400	12,000 / 79	18,850	57,300	1.64×10^7	60,000	1.50×10^7	0.95 / 4000	0.977	0.00915	0.005	0.003	175	22	G-14
RAS00412XX	400	12,000 / 68	18,850	57,300	1.64×10^7	60,000	1.50×10^7	1.00 / 4000	0.98	4.91×10^{-3}	0.008	0.004	175	8	G-9

General Purpose Stud Diodes (Refer to device datasheets at www.pwr.com for test conditions.)

Type		V_{RRM} Volts ($V_{RMS} = V_{RRM} + 100V$)	$I_{F(av)/T_C}$ Amperes/°C (180° sin)	$I_{F(RMS)}$ Amperes (180° sin)	EUROPEAN		NORTH AMERICAN		V_{FM}/I_{FM} Volts/Amperes ($T_j(max)$)	V_{T0} Volts ($T_j(max)$)	R_T mΩ ($T_j(max)$)	$R_{th(j-c)}$ °C/W	$R_{th(c-s)}$ °C/W	$T_j(max)$ °C	Outline Drawings	
					I_{FSM} Amperes (10ms, $T_j(max)$; No V_{RRM} Reapplied)	I^2t A ² sec (10ms, $T_j(max)$; No V_{RRM} Reapplied)	I_{FSM} Amperes (8.3ms, $T_j(max)$; 100% V_{RRM} Reapplied)	I^2t A ² sec (8.3ms, $T_j(max)$; 100% V_{RRM} Reapplied)							Number	Page
Up to 1600V																
R500--10XXWA, R501--10XXWA		200 – 1600	100 / 163	160	3,450	59,513	2,300	22,000	1.0 / 80	0.80	1.99	0.28	0.20	200	14	G-11
R500--15XXWA, R501--15XXWA		200 – 1600	150 / 147	236	4,500	101,250	3,000	37,500	1.0 / 100	0.85	1.08	0.28	0.20	200	14	G-11
R700--05XXUA, R701--05XXUA		200 – 1600	550 / 125	865	15,000	1.1×10^6	10,000	416,500	0.89 / 1000	0.65	0.25	0.12	0.04	200	17	G-12
R750--05XXUA, R751--05XXUA		200 – 1600	550 / 125	865	15,000	1.1×10^6	10,000	416,500	0.89 / 1000	0.65	0.25	0.12	0.04	200	19	G-13
Up to 2600V																
R600--20XXYA, R601--20XXYA		100 – 2600	200 / 140	315	8,250	340,313	5,500	125,000	1.32 / 500	0.84	0.94	0.18	0.10	150 – 190	15	G-11
R650--20XXYA, R651--20XXYA		100 – 2600	200 / 140	315	8,250	340,313	5,500	125,000	1.32 / 500	0.84	0.94	0.18	0.10	150 – 190	16	G-12
R600--25XXYA, R601--25XXYA		100 – 2600	250 / 130	400	9,000	405,000	6,000	150,000	1.24 / 500	0.88	0.72	0.18	0.10	150 – 190	15	G-11
R650--25XXYA, R651--25XXYA		100 – 2600	250 / 130	400	9,000	405,000	6,000	150,000	1.24 / 500	0.88	0.72	0.18	0.10	150 – 190	16	G-12
R600--30XXYA, R601--30XXYA		100 – 2600	300 / 123	470	9,750	475,313	6,500	175,000	1.17 / 500	0.92	0.53	0.18	0.10	150 – 190	15	G-11
R650--30XXYA, R651--30XXYA		100 – 2600	300 / 123	470	9,750	475,313	6,500	175,000	1.17 / 500	0.92	0.53	0.18	0.10	150 – 190	16	G-12
R700--04XXUA, R701--04XXUA		200 – 2600	450 / 100	700	12,750	812,813	8,500	266,000	1.25 / 1000	0.83	0.40	0.12	0.04	200	17	G-12
R750--04XXUA, R751--04XXUA		200 – 2600	450 / 100	700	12,750	812,813	8,500	266,000	1.25 / 1000	0.83	0.40	0.12	0.04	200	19	G-13
Up to 4500V																
R700--03XXUA, R701--03XXUA		200 – 4400	300 / 80	470	10,500	551,250	7,000	204,000	1.48 / 1000	0.92	0.55	0.12	0.04	200	17	G-12
R750--03XXUA, R751--03XXUA		200 – 4400	300 / 80	470	10,500	551,250	7,000	204,000	1.48 / 1000	0.92	0.55	0.12	0.04	200	19	G-13
R7F0--03XXUA, R7F1--03XXUA		200 – 4400	300 / 80	470	10,500	551,250	7,000	204,000	1.48 / 1000	0.92	0.55	0.12	0.04	200	18	G-12

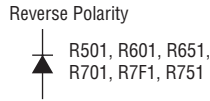



Fast Recovery Disc/Hockey Puk Diodes (Refer to device datasheets at www.pwr.com for test conditions.)

Type	V_{RRM} Volts ($V_{RMS} = V_{RRM} + 100V$)	$I_{F(av)/TC}$ Amperes/°C (180° sin)	$I_{F(RMS)}$ Amperes (180° sin)	EUROPEAN		NORTH AMERICAN		V_{FM}/I_{FM} Volts/Amperes ($T_j(max)$)	V_{T0} Volts ($T_j(max)$)	R_T mΩ ($T_j(max)$)	$R_{th(j-c)}$ °C/W	$R_{th(c-s)}$ °C/W	$T_j(max)$ °C	Outline Drawings	
				I_{FSM} Amperes (10ms, $T_j(max)$, No V_{RRM} Reapplied)	i^2t A ² sec (10ms, $T_j(max)$, No V_{RRM} Reapplied)	I_{FSM} Amperes (8.3ms, $T_j(max)$, No V_{RRM} Reapplied)	i^2t A ² sec (8.3ms, $T_j(max)$, No V_{RRM} Reapplied)							Number	Page
Up to 1600V															
R622--40*S00	200 – 1600	400 / 70	625	6,750	227,813	4,500	85,000	1.40 / 200	1.23	0.84	0.095	0.025	150	1	G-7
R622--55*S00	200 – 1600	550 / 70	860	9,000	405,000	6,000	150,000	1.29 / 700	0.97	0.44	0.095	0.025	150	1	G-7
R722--06*S00	200 – 1600	650 / 70	1000	11,250	632,813	7,500	234,000	1.51 / 400	1.12	0.67	0.055	0.020	150	4	G-8
R722--08*S00	200 – 1600	800 / 70	1,250	16,500	1.3 x 10 ⁶	11,000	504,000	1.22 / 400	1.08	0.36	0.055	0.020	150	4	G-8
R7S2--09*S00	200 – 1600	900 / 70	1,440	11,250	632,813	7,500	234,000	1.55 / 500	1.32	0.44	0.035	0.025	150	3	G-7
R7S2--10*S00	200 – 1600	1000 / 70	1,550	16,500	1,361,250	11,000	504,000	1.24 / 500	1.05	0.37	0.035	0.025	150	3	G-7
Up to 2600V															
R722--05*S00	200 – 2600	500 / 70	785	9,750	475,313	6,500	176,000	1.52 / 500	0.99	0.86	0.055	0.020	150	4	G-8
R722--07*S00	200 – 2600	700 / 70	1100	14,250	1.01 x 10 ⁶	9,500	376,000	1.0 / 300	0.87	0.57	0.055	0.020	150	4	G-8
R7S2--07*S00	200 – 2600	700 / 70	1100	9,750	475,313	6,500	176,000	1.42 / 400	1.10	0.72	0.035	0.025	150	3	G-7
R7S2--08*S00	200 – 2600	800 / 70	1,250	14,250	1.01 x 10 ⁶	9,500	376,000	1.17 / 500	0.86	0.55	0.035	0.025	150	3	G-7
Up to 3600V															
R9G2--12*S00	200 – 3600	1200 / 70	1,900	21,000	2.2 x 10 ⁶	14,000	820,000	1.95 / 1000	1.18	0.62	0.018	0.008	150	5	G-8
R9G2--15*S00	200 – 3600	1500 / 70	2,350	27,000	3.6 x 10 ⁶	18,000	1.35 x 10 ⁶	1.5 / 1000	1.04	0.39	0.018	0.008	150	5	G-8

Fast Recovery Stud Diodes (Refer to device datasheets at www.pwr.com for test conditions.)

Type	V_{RRM} Volts ($V_{RMS} = V_{RRM} + 100V$)	$I_{F(av)/TC}$ Amperes/°C (180° sin)	$I_{F(RMS)}$ Amperes (180° sin)	EUROPEAN		NORTH AMERICAN		V_{FM}/I_{FM} Volts/Amperes ($T_j(max)$)	V_{T0} Volts ($T_j(max)$)	R_T mΩ ($T_j(max)$)	$R_{th(j-c)}$ °C/W	$R_{th(c-s)}$ °C/W	$T_j(max)$ °C	Outline Drawings	
				I_{FSM} Amperes (10ms, $T_j(max)$, No V_{RRM} Reapplied)	i^2t A ² sec (10ms, $T_j(max)$, No V_{RRM} Reapplied)	I_{FSM} Amperes (8.3ms, $T_j(max)$, No V_{RRM} Reapplied)	i^2t A ² sec (8.3ms, $T_j(max)$, No V_{RRM} Reapplied)							Number	Page
Up to 1600V															
R502--13*SWA, R503--13*SWA	200 – 1400	125 / 70	195	3,750	70,313	2,500	26,000	1.84 / 200	1.17	3.09	0.28	0.12	150	14	G-11
R502--18*SWA, R503--18*SWA	200 – 1400	175 / 70	275	5,250	137,813	3,500	51,000	1.48 / 300	0.85	1.57	0.28	0.12	150	14	G-11
R602--25*SYA, R603--25*SYA	200 – 1600	250 / 70	400	6,750	227,813	4,500	85,000	1.39 / 200	1.20	0.86	0.17	0.10	150	15	G-11
R602--35*SYA, R603--35*SYA	200 – 1600	350 / 70	550	9,000	405,000	6,000	150,000	1.18 / 400	0.95	0.51	0.17	0.10	150	15	G-11

Forward Polarity
 R502, R602

Reverse Polarity
 R503, R603

1 R620, R622

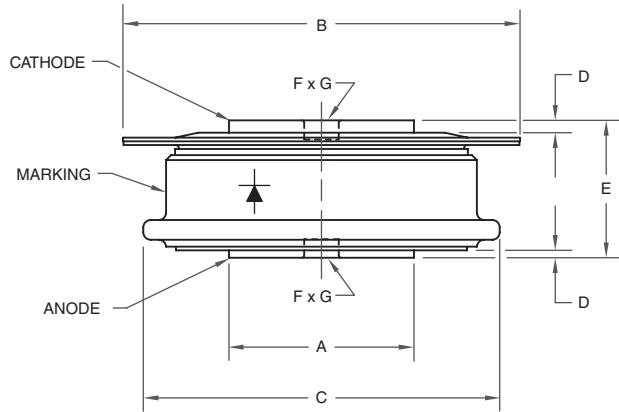

2 R7S0 ($\leq 1600V$)

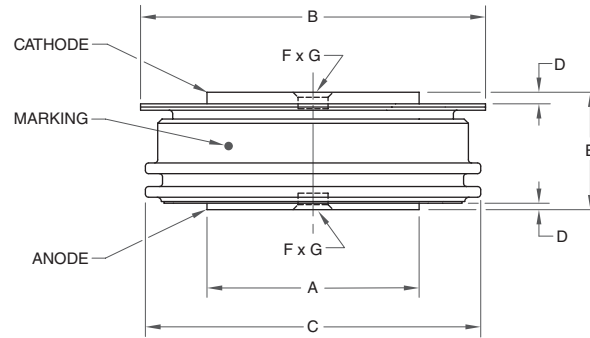

3 R7S0 ($\geq 1800V$), R7S2

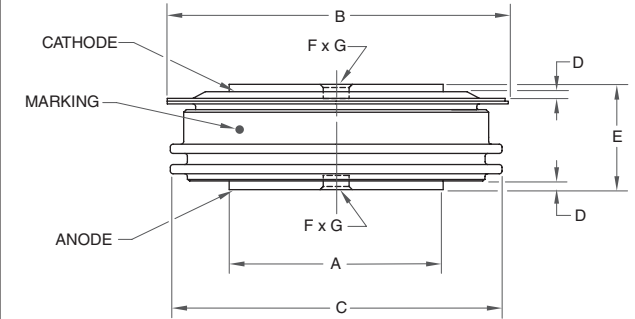

Dim.	Inches	Millimeters
A	0.752 Dia.	19.1 Dia.
B	1.658 Dia.	42.1 Dia.
C	1.461 Dia.	37.1 Dia.
D	0.0197 Min.	0.5 Min.

Dim.	Inches	Millimeters
E	0.567 Max.	14.4 Max.
F	0.142 Dia.	3.6 Dia.
G	0.0787 Deep	2.0 Deep

Dim.	Inches	Millimeters
A	0.995 Dia.	25.27 Dia.
B	1.650 Dia.	41.9 Dia.
C	1.585 Dia.	40.26 Dia.
D	0.040 Min.	1.01 Min.

Dim.	Inches	Millimeters
E	0.605 Max.	15.37 Max.
F	0.145 Dia.	3.68 Dia.
G	0.0787 Deep	2.0 Deep

Dim.	Inches	Millimeters
A	1.17 Dia.	29.7 Dia.
B	1.90 Dia.	48.3 Dia.
C	1.85 Dia.	47.0 Dia.
D	0.028 Min.	0.7 Min.

Dim.	Inches	Millimeters
E	0.606 Max.	15.4 Max.
F	0.142 Dia.	3.6 Dia.
G	0.0787 Deep	2.0 Deep

4 R720, R722, R820, R8K8

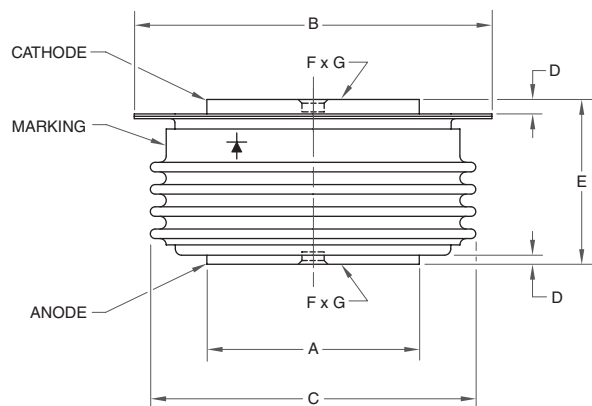

Dim.	Inches	Millimeters
A	1.343 Dia.	34.1 Dia.
B	2.299 Dia.	58.4 Dia.
C	2.091 Dia.	53.1 Dia.
D	0.028 Min.	0.7 Min.

5 R9G0, R9G2

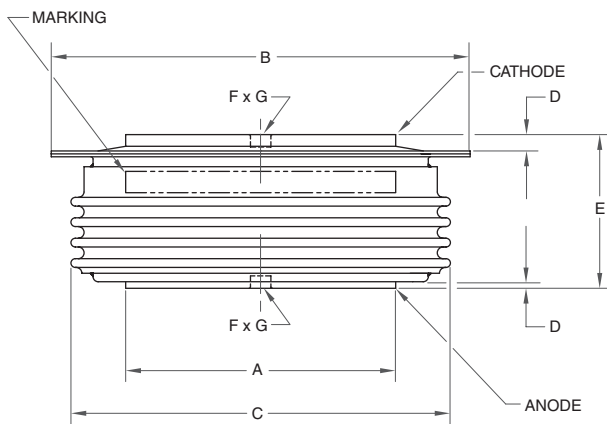

Dim.	Inches	Millimeters
A	1.858 Dia.	47.2 Dia.
B	2.8898 Dia.	73.4 Dia.
C	2.6496 Dia.	67.3 Dia.
D	0.028 Min.	0.7 Min.

6 R9S0

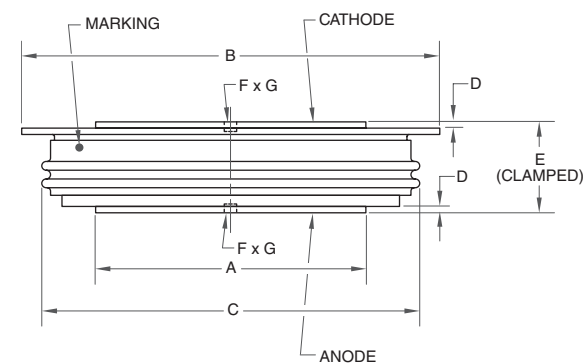

Dim.	Inches	Millimeters
A	1.85 Dia.	47.0 Dia.
B	2.913 Dia.	74.0 Dia.
C	2.638 Dia.	67 Dia.
D	0.028 Min.	0.7 Min.

7 RA20

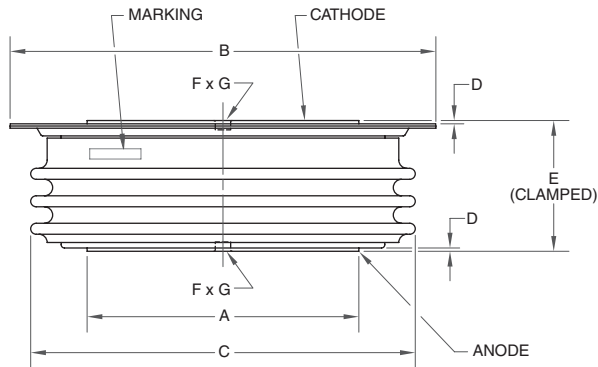

Dim.	Inches	Millimeters
A	2.469 Dia.	62.7 Dia.
B	3.909 Dia.	99.3 Dia.
C	3.543 Dia.	90.0 Dia.
D	0.028 Min.	0.7 Min.

Dim.	Inches	Millimeters
E	1.339 Max.	34.0 Max.
F	0.142 Dia.	3.6 Dia.
G	0.0787 Deep	2.0 Deep

8 RAS8, RAS00412XX

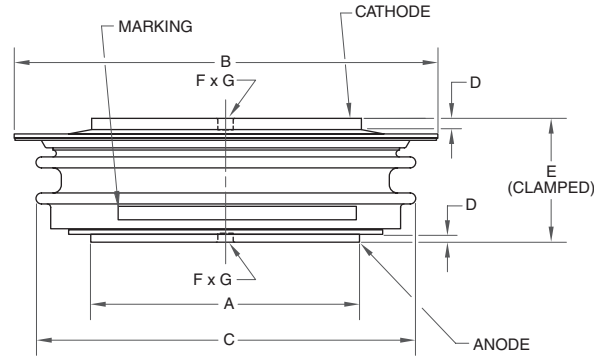

Dim.	Inches	Millimeters
A	2.48 Dia.	63.0 Dia.
B	3.93 Dia.	100.0 Dia.
C	3.543 Dia.	91.0 Dia.
D	0.028 Min.	0.7 Min.

Dim.	Inches	Millimeters
E	1.031 Max.	26.2 Max.
F	0.14 Dia.	3.5 Dia.
G	0.07 Deep	1.8 Deep

9 RBS8, RBT8

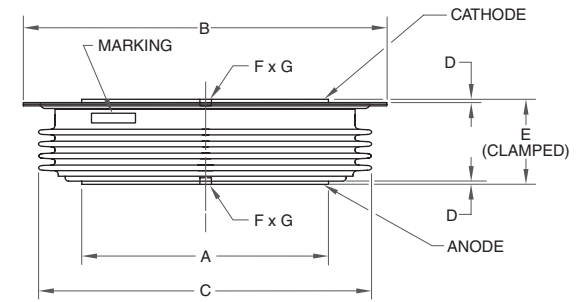

RBS8

Dim.	Inches	Millimeters
A	2.88 Dia.	73.2 Dia.
B	4.36 Dia.	110.7 Dia.
C	3.95 Dia.	100.3 Dia.
D	0.03 Min.	0.76 Min.

Dim.	Inches	Millimeters
E	1.08 Max.	27.4 Max.
F	0.142 Dia.	3.6 Dia.
G	0.0787 Deep	2.0 Deep

RBT8

Dim.	Inches	Millimeters
A	2.88 Dia.	73.2 Dia.
B	4.36 Dia.	110.7 Dia.
C	3.95 Dia.	100.3 Dia.
D	0.03 Min.	0.76 Min.

Dim.	Inches	Millimeters
E	1.04 Max.	26.5 Max.
F	0.142 Dia.	3.6 Dia.
G	0.0787 Deep	2.0 Deep

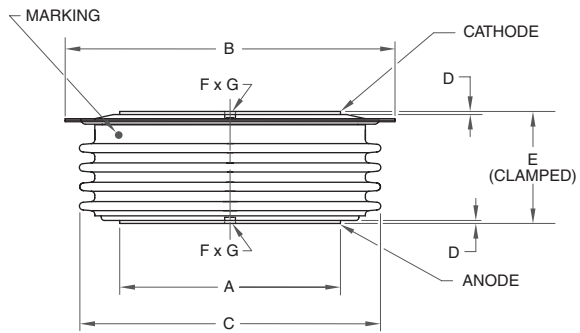
10 RBK8

Dim.	Inches	Millimeters
A	2.882 Dia.	73.2 Dia.
B	4.36 Dia.	110.7 Dia.
C	3.961 Dia.	100.6 Dia.
D	0.028 Min.	0.7 Min.

Dim.	Inches	Millimeters
E	1.5 Max.	38.1 Max.
F	0.142 Dia.	3.6 Dia.
G	0.0787 Deep	2.0 Deep

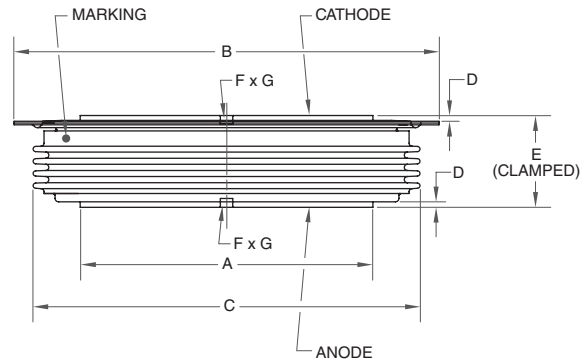
11 RCS8

Dim.	Inches	Millimeters
A	3.311 Dia.	84.1 Dia.
B	4.889 Dia.	124.2 Dia.
C	4.370 Dia.	111.0 Dia.
D	0.028 Min.	0.7 Min.

Dim.	Inches	Millimeters
E	1.059 Max.	26.9 Max.
F	0.142 Dia.	3.6 Dia.
G	0.0787 Deep	2.0 Deep

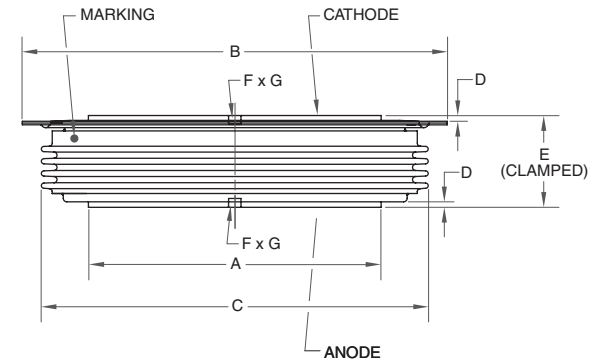
12 RDS8

Dim.	Inches	Millimeters
A	3.913 Dia.	99.4 Dia.
B	5.661 Dia.	143.8 Dia.
C	5.181 Dia.	131.6 Dia.
D	0.028 Min.	0.7 Min.

Dim.	Inches	Millimeters
E	1.059 Max.	26.9 Max.
F	0.142 Dia.	3.6 Dia.
G	0.0787 Deep	2.0 Deep

13 RDK8

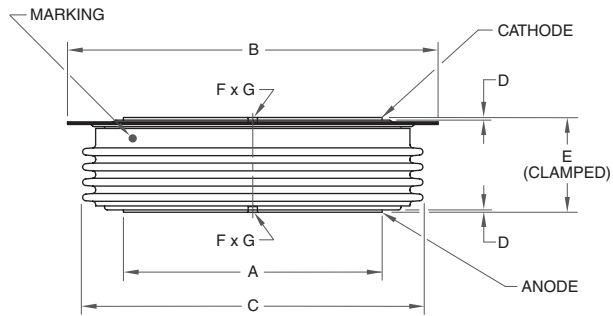

Dim.	Inches	Millimeters
A	3.913 Dia.	99.4 Dia.
B	5.661 Dia.	143.8 Dia.
C	5.181 Dia.	131.6 Dia.
D	0.028 Min.	0.7 Min.

Dim.	Inches	Millimeters
E	1.5 Max.	38.1 Max.
F	0.142 Dia.	3.6 Dia.
G	0.0787 Deep	2.0 Deep

14 R500, R501, R502, R503

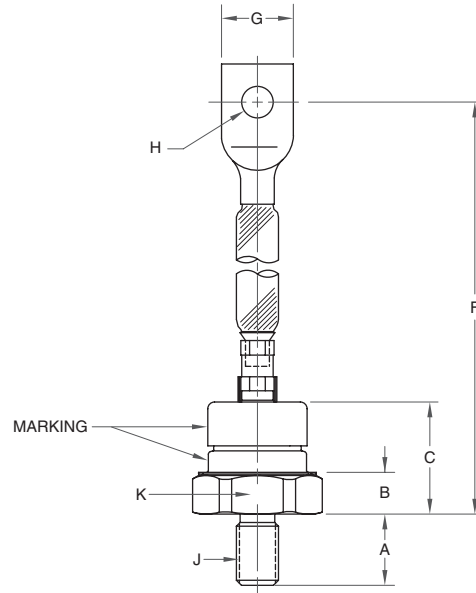

Dim.	Inches	Millimeters
A	0.626	15.9
B	0.358	9.1
C	0.980	24.9
F	4.606 Max.	117.0 Max.
G	0.654 Max.	16.6 Max.

Forward Polarity

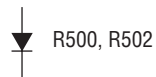

Reverse Polarity

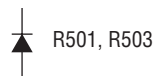

15 R600, R601, R602, R603

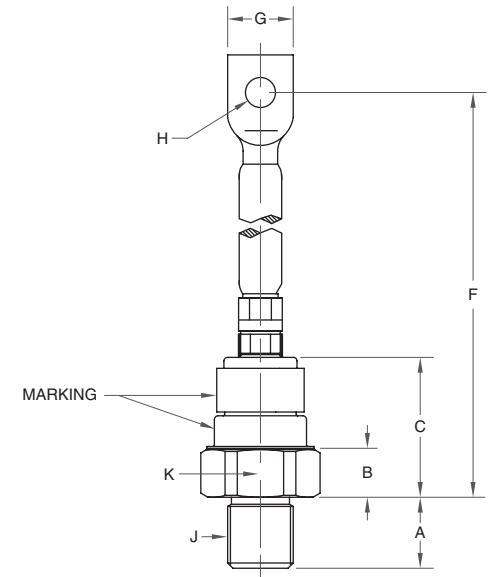

Dim.	Inches	Millimeters
A	0.811	20.6
B	0.559	14.2
C	1.598	40.6
F	5.563 Max.	141.3 Max.
G	0.752 Max.	19.1 Max.

Dim.	Inches	Millimeters
H	0.343 Dia.	8.7 Dia.
J	0.750-16 UNF-2A Thread	
K	1.244 Max.	31.6 Max.

Forward Polarity

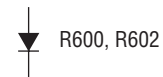

Reverse Polarity



16 R650

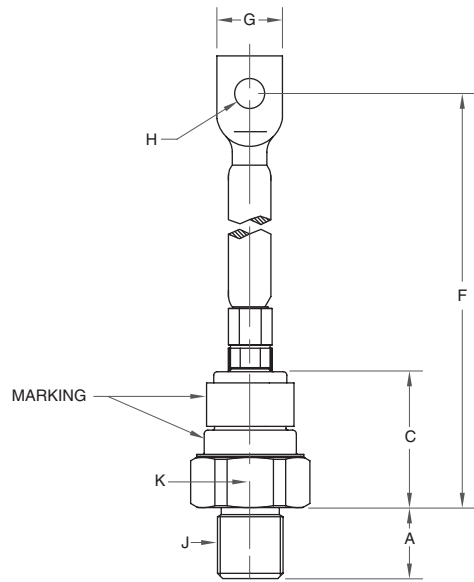

Dim.	Inches	Millimeters	Dim.	Inches	Millimeters
A	0.822	20.88	H	0.343 Dia.	8.72 Dia.
C	1.56	39.68	J	M20 x 1.5	
F	5.56 Max.	141.228 Max.	K	1.245 Max.	31.776 Max.
G	19.05 Max.	0.75 Max.		(Across Flats)	

Forward Polarity



R650

Reverse Polarity



R651

17 R700, R701

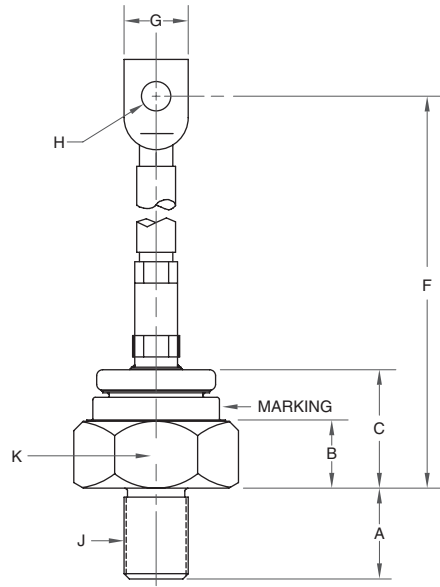

Dim.	Inches	Millimeters	Dim.	Inches	Millimeters
A	1.059	26.9	H	0.343 Dia.	8.7 Dia.
B	0.7795	19.8	J	0.750-16 UNF-2A Thread	
C	1.409	35.8	K	1.752 Max.	44.5 Max.
F	9.784 Max.	248.5 Max.		(Across Flats)	
G	0.752 Max.	19.1 Max.			

Forward Polarity



R700

Reverse Polarity



R701

18 R7F0, R7F1

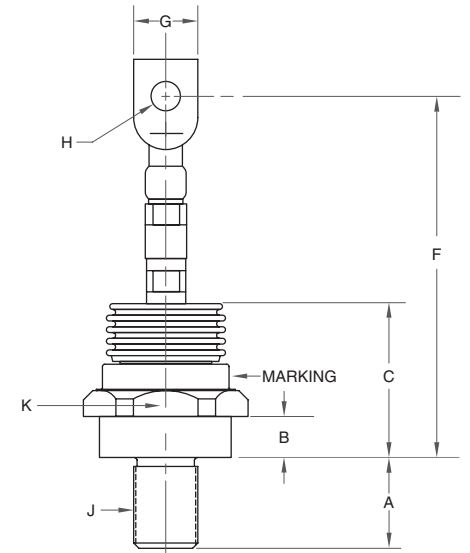

Dim.	Inches	Millimeters	Dim.	Inches	Millimeters
A	1.062	26.97	H	0.343 Dia.	8.73 Dia.
B	0.47	11.94	J	0.750-16 UNF-2A Thread	
C	1.81	45.97	K	1.750 Max.	44.45 Max.
F	4.25 Max.	107.95 Max.		(Across Flats)	
G	0.75 Max.	19.05 Max.			

Forward Polarity



R7F0

Reverse Polarity



R7F1

19 R750

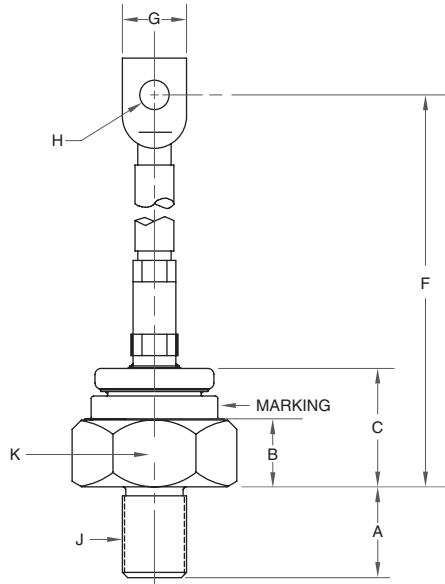

Dim.	Inches	Millimeters
A	1.06	20.9
B	0.75	19.0
C	1.46	37.0
F	9.78 Max.	248.4 Max.
G	0.740 Max.	21.5 Max.

Dim.	Inches	Millimeters
H	0.355 Dia.	9.0 Dia.
J		M24 x 1.5
K	1.755 Max.	44.6 Max.

(Across Flats)

20 R9XSMD0448XX, R9XSMD0463XX

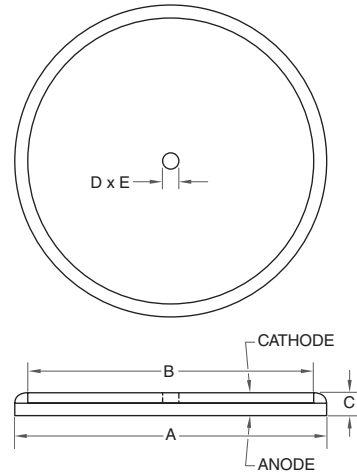

Dim.	Inches	Millimeters
A	1.97 Dia.	50.0 Dia.
B	1.7 Dia.	43.2 Dia.
C	0.20	5.0

Dim.	Inches	Millimeters
D	0.142 Dia.	3.6 Dia.
E	0.047 Deep	1.2 Deep

21 R9XSMD0475XX

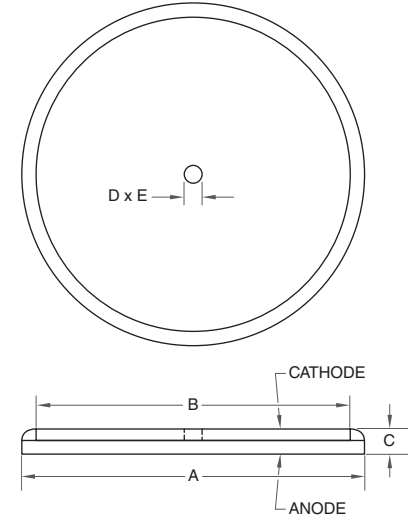

Dim.	Inches	Millimeters
A	2.20 Dia.	56.0 Dia.
B	1.937 Dia.	49.2 Dia.
C	0.2	5.0

Dim.	Inches	Millimeters
D	0.142 Dia.	3.6 Dia.
E	0.047 Deep	1.2 Deep

Forward Polarity



R750

Reverse Polarity



R751

22 RAXMHC0412XX

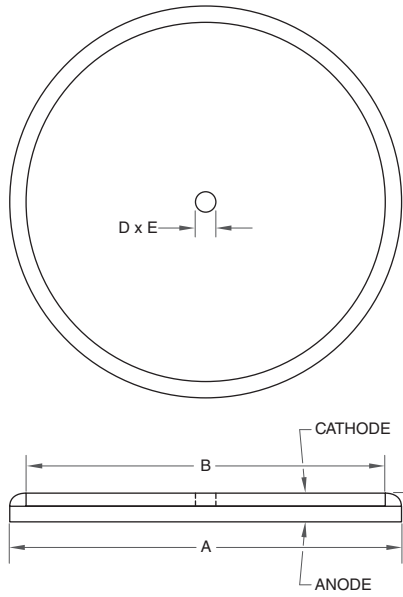

Dim.	Inches	Millimeters	Dim.	Inches	Millimeters
A	2.56 Dia.	65.0 Dia.	D	0.142 Dia.	3.6 Dia.
B	2.28 Dia.	58.0 Dia.	E	0.047 Deep	1.2 Deep
C	0.20	5.0			

THYRISTOR & DIODE MODULES

POW-R-BLOK™ Modules

Applications Include:

- Battery Chargers
- Induction Heating/Melting
- Medical Equipment
- Motor Controls
- Power Supplies
- UPS
- Welding

POW-R-BRIK™

Applications Include:

- AC Motor Starters
- DC Motor Controls
- Mining Power Centers
- Resistance Welding Controls
- Transportation

Circuit Configurations:

- Single
- Dual
- Split Dual
- Common Anode
- Common Cathode
- AC Switch

TABLE OF CONTENTS

Numbering System	H-2
Optional Cathode & Gate Lead Kits for POW-R-BLOK™ Modules	H-3
Optional Hardware for ND, NS, LD & LS POW-R-BLOK™ Modules	H-3
Diode Modules	H-4
Thyristor Modules	H-6
Thyristor / Diode Modules	H-9
Thyristor / Diodes (POW-R-BRIKs™)	H-10
Outline Drawings	H-11



POW-R-BLOK™ Modules
VOLTAGE: 600V TO 5000V
CURRENT: 90A TO 2500A

POW-R-BRIK™ Modules
VOLTAGE: 600V TO 5000V
CURRENT: 300A TO 1585A

Numbering System

Thyristor (SCR) and Diode Modules

CD431290B is a 90 Ampere, 1200 Volt, Dual Switch Module

CD 4 3 12 90 B
 (1) (2) (3) (4) (5) (6)

(1) Type Number:

CD, ND, LD, PD = Dual Switches
 CS, LS, PS = Single Switches
 PA = AC Switch
 CC = Common Cathode
 CN, LN = Common Anode

(2) Package Style

(3) Configuration:

1 = Diode
 2 = SCR / Diode
 3 = SCR
 7 = Diode / SCR

(4) Voltage Rating (x 100):

08 = 800V
 12 = 1200V
 16 = 1600V
 20 = 2000V
 24 = 2400V
 36 = 3600V
 40 = 4000V
 50 = 5000V

(5) Current Rating:

Device	Current
CD4	A2 = 25A
CS4	40 = 40A
CC4	50 = 50A
CN4	60 = 60A
	90 = 90A
	99 = 100A
CD6	x 10
CS6	Example:
ND	25 = 250A
LD	
LS	
PD	x 100
PA	Example:
	07 = 700A
PS	14 = 1400A
PS	15 = 1500A
PS	20 = 2000A
PS	25 = 2500A

(6) Suffix Identifier:

B, C or D

QRD6516001 is a 160 Ampere, 6500 Volt, Dual Switch Module

Q R D 65 16 001
 (1) (2) (3) (4) (5) (6)

(1) Product Line

(2) Type Number:
 R = Rectifier

(3) Package Style:
 D = Dual Switch

(4) Voltage Rating (x 100)

(5) Current (x 10)

(6) Serial Designation:
 001 = Special Designation

POW-R-BRIKs™

P3Z7ACT700W16 is a 1600 Volt, Dual SCR Module with Standard Thermistor

P3 Z 7 A CT7 00 W16
 (1) (2) (3) (4) (5) (6) (7)

(1) Type Number:

P1 = Dual Diode
 P2 = SCR / Diode
 P3 = Dual SCR
 P7 = Diode / SCR

(2), (3), (4) Package Style

(3) Indicates Size of the Block & Elements

(5) Element Code:

Refer to Product Datasheet for the Element Codes to Reference the Corresponding Disc Device for Additional Specifications

(6) Special Features:

00 = Module Includes Standard Thermistor
 XT = No Thermistor
 All Other Codes Denote Unique Customer Specifications

(7) Voltage Rating:

V04 = 400V
 V08 = 800V
 W12 = 1200V
 W16 = 1600V

Optional Cathode & Gate Lead Kits for POW-R-BLOK™ Modules

Type	Description	Lead Kit	Outline Drawings	
			Number	Page
CD42, CD47 (Half Control)	One red & one yellow lead per module	MR	14	H-15
CD43 (Full Control)	Two red & two yellow leads per module	MQ	14	H-15
CD63, LD43, ND43, PD43(Full Control)	Lead Set 1 & Lead Set 2 (one each/module)	NK	15	H-16
CD62, LD42, LS43, ND42(Half Control), PD47	Lead Set 1 (one/module)	NL	15	H-16
CD67, LD47, ND47, PD42, PS43 (Half Control)	Lead Set 2 (one/module)	NM	15	H-16

Optional Hardware for ND, NS, LD and LS POW-R-BLOK™ Modules

Type	Hardware Kit	Description
ND	87	Three M8 x 1.25 screws (16mm in length) with captive lock washer and flat washer
NS	86	Two M8 x 1.25 screws (16mm in length) with captive lock washer and flat washer
LD	50	Three M10 x 1.5 screws (20mm in length) and three 10mm lock washers
LS	49	Two M10 x 1.5 screws (20mm in length) and two 10mm lock washers

Diode Modules (Refer to device datasheets at www.pwrx.com for test conditions.)



Type	V _{DRM} / V _{RRM} Volts (V _{RSM} = V _{RRM} + 100V)	I _{F(av)} /T _C Amperes/°C (180° sin)	I _{F(RMS)} Amperes (180° sin)	EUROPEAN		NORTH AMERICAN		V _{FM} /I _{FM} Volts/Amperes (T _{j(max)})	V _{TO} Volts (T _{j(max)})	R _T mΩ (T _{j(max)})	R _{th(j-c)} °C/W	R _{th(c-s)} °C/W	T _{j(max)} °C	Outline Drawings	
				I _{FSM} Amperes (10ms, T _{j(max)} , No V _{RRM} Reapplied)	i ² t A ² sec (10ms, T _{j(max)} , No V _{RRM} Reapplied)	I _{FSM} Amperes (8.3ms, T _{j(max)} , 100% V _{RRM} Reapplied)	i ² t A ² sec (8.3ms, T _{j(max)} , 100% V _{RRM} Reapplied)							Number	Page
Single Diode Modules															
CS61--16C	800 – 1800	160 / 99	250	6,600	217,800	4,822	96,880	1.56 / 480 (25°C)	0.80	1.35	0.23	0.08	150	10	H-14
CS61--16C	2000 – 2500	160 / 95	250	6,600	217,800	4,822	96,880	1.66 / 480 (25°C)	0.80	1.45	0.23	0.08	150	10	H-14
CS61--16C	2600 – 3600	160 / 90	250	5,720	163,590	4,179	72,760	1.90 / 480 (25°C)	0.90	1.35	0.23	0.08	150	10	H-14
◆LS81--45	3200 – 4000	450 / 107	710	15,050	1.13 x 10 ⁶	11,000	504,000	1.90 / 1800 (150°C)	0.85	0.55	0.065	0.02	150	3	H-11
◆LS41--60	800 – 2400	600 / 106	950	31,500	4.9 x 10 ⁶	21,000	1.8 x 10 ⁶	1.16 / 1500	0.747	0.243	0.065	0.02	150	3	H-11
◆NS412426	800 – 2000	260 / 112	408	12,000	720,000	8,000	266,667	1.35 / 1500	0.764	0.360	0.07	0.03	150	5	H-12
PS415014	4500 – 5000	1400 / 91	2,200	32,700	7.19 x 10 ⁶	24,000	2.39 x 10 ⁶	1.30 / 3000	0.71	0.17	0.032	0.009	150	4	H-12
PS41--20	3600 – 4000	2000 / 99	3,140	60,690	18.4 x 10 ⁶	47,600	9.4 x 10 ⁶	1.2 / 3000 (150°C)	0.745	0.064	0.024	0.009	150	4	H-12
PS41--25	800 – 2400	2500 / 90	3,925	72,600	26.3 x 10 ⁶	53,000	11.7 x 10 ⁶	1.10 / 3000 (25°C)	0.681	0.051	0.024	0.009	150	4	H-12

◆For Optional Hardware go to Page H-3.

Single Diode Modules

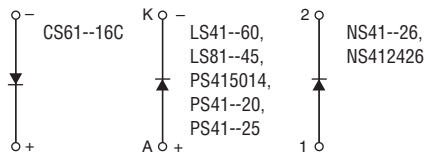

Diode Modules (Refer to device datasheets at www.pwr.com for test conditions.)



CD41--99C,
CD411699D



CD61--16C,
CD614020C



ND41



LD41,
LD81



PD41



QRD4518001,
QRD6516001

Type	V _{DRM} / V _{RRM} Volts (V _{RSM} = V _{RRM} + 100V)	I _{F(av)} /T _C Amperes/°C (180° sin)	I _{F(RMS)} Amperes (180° sin)	EUROPEAN		NORTH AMERICAN		V _{FM} /I _{FM} Volts/Amperes (T _{J(max)})	V _{TO} Volts (T _{J(max)})	R _T mΩ (T _{J(max)})	R _{th(j-c)} °C/W	R _{th(c-s)} °C/W	T _{J(max)} °C	Outline Drawings	
				I _{FSM} Amperes (10ms, T _{J(max)} , No V _{RRM} Reapplied)	i ² t A ² sec (10ms, T _{J(max)} , No V _{RRM} Reapplied)	I _{FSM} Amperes (8.3ms, T _{J(max)} , 100% V _{RRM} Reapplied)	i ² t A ² sec (8.3ms, T _{J(max)} , 100% V _{RRM} Reapplied)							Number	Page
Dual Diode Modules															
CD41--99C	800 – 1800	100 / 104	157	2,860	40,890	2,089	18,190	1.45 / 330 (25°C)	0.80	1.74	0.35	0.15	150	8	H-13
CD41--99C	2000 – 2500	100 / 101	157	2,860	40,890	2,089	18,190	1.65 / 330 (25°C)	0.85	1.88	0.35	0.15	150	8	H-13
CD411699D	1600	100 / 106	157	2,860	40,890	2,089	18,190	1.35 / 300 (25°C)	0.85	1.30	0.35	0.15	150	8	H-13
CD61--16C	800 – 1800	160 / 99	250	6,600	217,800	4,822	96,880	1.56 / 480 (25°C)	0.80	1.35	0.23	0.08	150	10	H-14
CD61--16C	2000 – 2500	160 / 95	250	6,600	217,800	4,822	96,880	1.66 / 480 (25°C)	0.80	1.45	0.23	0.08	150	10	H-14
CD61--16C	2600 – 3600	160 / 90	250	5,720	163,590	4,179	72,760	1.90 / 480 (25°C)	0.90	1.35	0.23	0.08	150	10	H-14
CD61--20C	3600 – 4000	200 / 100	314	7,500	281,000	—	—	1.69 / 440 (25°C)	0.95	1.40	0.5	0.04	150	10	H-14
QRD4518001	4500	180 / 95	282	5,215	151,000	3,860	140,000	1.35 / 180	0.27	5.216	0.099	0.018	150	16	H-16
QRD6516001	6500	160 / 100	251	TBD	TBD	TBD	TBD	1.25 / 160 (Typ.)	0.776	8.081	TBD	TBD	150	16	H-16
◆ND41--25	2600 – 3400	250 / 101	392	7,125	254,000	5,000	104,000	1.80 / 1500	1.095	0.48	0.07	0.14	150	5	H-12
◆ND41--26	800 – 2600	260 / 112	408	12,000	720,000	8,000	266,667	1.35 / 1500	0.764	0.360	0.07	0.03	150	5	H-12
◆ND41--32	800 – 2000	320 / 101	502	12,000	720,000	8,000	266,667	1.35 / 1500	0.764	0.360	0.07	0.03	150	5	H-12
◆ND41--35	800 – 1800	350 / 102	550	11,000	605,000	8,450	297,510	1.15 / 1500	0.654	0.320	0.07	0.03	150	5	H-12
◆LD81--45	3200 – 4000	450 / 107	710	15,050	1.13 x 10 ⁶	11,000	504,000	1.90 / 1800	0.85	0.55	0.0325	0.065	150	6	H-12
◆LD41--60	800 – 2600	600 / 106	950	31,500	4.9 x 10 ⁶	21,000	1.8 x 10 ⁶	1.16 / 1500	0.747	0.243	0.0325	0.01	150	6	H-12
PD41--10	3600 – 4000	1000 / 87	1570	35,700	—	28,000	3.6 x 10 ⁶	1.35 / 3000	0.741	0.132	0.029	0.009	150	4	H-12
PD41--11	800 – 2400	1100 / 87	1725	40,350	8.1 x 10 ⁶	29,500	3.26 x 10 ⁶	1.00 / 3000	0.869	0.237	0.029	0.009	150	4	H-12

◆For Optional Hardware go to Page H-3.

Dual Diode Modules

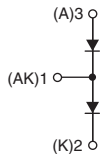

CD41--99C, CD41--99D, CD61--16C, CD614020C,
ND41--25, ND41--26, ND41--32, ND41--35,
LD41--60, LD81--45,
PD41--10, PD41--11

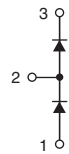

QRD4518001,
QRD6516001

Thyristor Modules

(Refer to device datasheets at www.pwr.com for test conditions.)

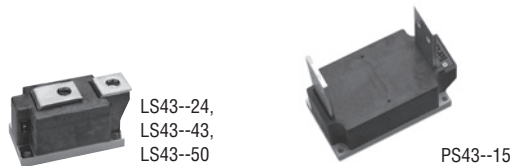

Type	V _{DRM} / V _{RRM} Volts (V _{RSM} = V _{RRM} + 100V)	I _{T(av)} /T _C Amperes/°C (180° sin)	I _{T(RMS)} Amperes (180° sin)	EUROPEAN		NORTH AMERICAN		V _{TM} /I _{TM} Volts/Amperes (T _{J(max)})	V _{TO} Volts (T _{J(max)})	R _T mΩ (T _{J(max)})	di/dt Amperes/μsec (Non-Repelitive)	dV/dt Volts/μsec	R _{th(j-c)} °C/W	R _{th(c-s)} °C/W	T _{J(max)} °C	Outline Drawings Number	Page
				I _{TSM} Amperes (10ms, T _{J(max)} , No V _{RRM} Reapplied)	i ² t A ² sec (10ms, T _{J(max)} , No V _{RRM} Reapplied)	I _{TSM} Amperes (8.3ms, T _{J(max)} , 100% V _{RRM} Reapplied)	i ² t A ² sec (8.3ms, T _{J(max)} , 100% V _{RRM} Reapplied)										
◆●LS43--24	3600 – 4000	240 / 74	377	7,525	236,000	5,500	126,000	3.5 / 1000 (25°C)	1.563	2.141	TBD	1000	0.065	0.02	125	3	H-11
◆●LS43--43	1800 – 2200	430 / 80	800	12,000	0.72 x 10 ⁶	12,000	0.82 x 10 ⁶	1.77 / 1500	0.88	0.66	200	1000	0.065	0.02	130	3	H-11
◆●LS43--50	600 – 1600	500 / 86	900	25,500	3.25 x 10 ⁶	17,000	1.20 x 10 ⁶	1.29 / 1500	0.81	0.32	200	1000	0.065	0.02	130	3	H-11
●PS43--15	600 – 1800	1500 / 86	2355	93,000	43.2 x 10 ⁶	68,000	19.3 x 10 ⁶	1.02 / 3000	0.691	0.102	400	200	0.024	0.009	125	4	H-12
●PS43--15	2000 – 2400	1500 / 76	2355	74,640	27.8 x 10 ⁶	54,570	12.4 x 10 ⁶	1.50 / 3000 (25°C)	0.849	0.130	400	300	0.024	0.009	125	4	H-12

◆ For Optional Hardware go to Page H-3.

● For Optional Cathode & Gate Lead Kits, go to page H-3.

Single Thyristor Modules

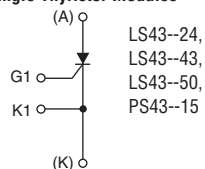

Thyristor Modules (Refer to device datasheets at www.pwr.com for test conditions.)

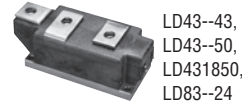

Type	V _{DRM} / V _{RRM} Volts (V _{RSM} = V _{RRM} + 100V)	I _{T(av)} /T _C Amperes/°C (180° sin)	I _{T(RMS)} Amperes (180° sin)	EUROPEAN		NORTH AMERICAN		V _{TM} /I _{TM} Volts/Amperes (T _{J(max)})	V _{T0} Volts (T _{J(max)})	R _T mΩ (T _{J(max)})	di/dt Amperes/μsec (Non-Repetitive)	dV/dt Volts/μsec	R _{th(j-c)} °C/W	R _{th(c-s)} °C/W	T _{J(max)} °C	Outline Drawings	
				I _{TSM} Amperes (10ms, T _{J(max)} , No V _{RRM} Reapplied)	i ² t A ² sec (10ms, T _{J(max)} , No V _{RRM} Reapplied)	I _{TSM} Amperes (8.3ms, T _{J(max)} , 100% V _{RRM} Reapplied)	i ² t A ² sec (8.3ms, T _{J(max)} , 100% V _{RRM} Reapplied)									Number	Page
●CD43--90B	800 – 1800	90 / 87	140	1,785	15,910	1,570	10,270	1.10 / 100	0.80	2.40	150	500	0.135	0.1	125	1	H-11
●CD43--90C	800 – 1800	90 / 85	141	2,200	24,200	1,600	10,760	1.70 / 270 (25°C)	0.80	3.01	TBD	800	0.28	0.15	125	9	H-14
●CD43--99C	1600 – 1800	100 / 88	157	2,640	34,800	1,930	15,500	1.83 / 270 (25°C)	0.80	3.01	TBD	800	0.25	0.15	125	9	H-14
●CD63--15B	800 – 1800	160 / 85	250	4,870	119,000	4,300	76,700	0.99 / 100	0.80	1.67	300	1000	0.08	0.05	125	2	H-11
●CD63--15C	800 – 1800	150 / 86	235	5,940	176,415	4,340	78,470	1.70 / 480 (25°C)	0.80	1.69	TBD	800	0.17	0.08	125	11	H-14
●CD63--15C	2000 – 2500	150 / 83	235	4,950	122,510	3,615	54,490	2.20 / 480 (25°C)	1.10	1.96	TBD	800	0.17	0.08	125	11	H-14
◆●ND43--21	600 – 2000	210 / 92	330	13,200	871,200	8,800	320,000	1.30 / 625	0.813	0.810	800	500	0.07	0.03	130	5	H-12
◆●LD83--24	3600 – 4000	240 / 74	377	7,525	236,000	5,500	126,000	3.5 / 1000 (25°C)	1.563	2.141	TBD	1000	0.0325	0.065	125	6	H-12
◆●ND43--25	600 – 1600	250 / 89	393	13,200	871,200	8,800	322,000	1.20 / 625	0.819	0.589	800	500	0.07	0.03	130	5	H-12
◆●ND43--25	1800 – 2000	250 / 84	393	13,200	871,200	8,800	322,000	1.36 / 625	0.877	0.731	800	500	0.07	0.03	130	5	H-12
◆●ND43--33	800 – 1600	330 / 71	520	11,850	702,000	8,800	322,667	1.3 / 625 (25°C)	0.819	0.59	800	500	0.07	0.03	130	5	H-12
◆●LD43--43	1800 – 2200	430 / 80	800	12,000	0.72 x 10 ⁶	12,000	0.82 x 10 ⁶	1.77 / 1500	0.88	0.66	200	1000	0.0325	0.01	130	6	H-12
◆●LD43--50	600 – 1600	500 / 86	900	25,500	3.25 x 10 ⁶	17,000	1.20 x 10 ⁶	1.29 / 1500	0.81	0.32	200	1000	0.0325	0.01	130	6	H-12
◆●LD431850	1800	500 / 84	900	25,500	3.25 x 10 ⁶	17,000	1.20 x 10 ⁶	1.4 / 1500	0.916	0.280	200	1000	0.0325	0.01	130	6	H-12
●PD43--06	2000 - 2400	600 / 81	942	40,350	8.14 x 10 ⁶	29,500	3.63 x 10 ⁶	1.60 / 3000	0.869	0.237	400	200	0.029	0.009	125	4	H-12
●PD43--07	600 - 1800	700 / 82	1100	54,750	14.9 x 10 ⁶	40,000	6.60 x 10 ⁶	1.30 / 3000	0.703	0.184	400	200	0.029	0.009	125	4	H-12

◆For Optional Hardware go to Page H-3.

●For Optional Cathode & Gate Lead Kits, go to page H-3.

Dual Thyristor Modules and AC Switches

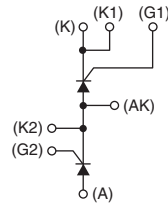

CD43--90B, CD43--90C, CD--99C,
CD63--15B, CD63--15C,
LD43--43, LD43--50, LD431850, LD83--24,
ND43--21, ND43--25, ND43--33,
PD43--06, PD43--07

Thyristor Modules

(Refer to device datasheets at www.pwr.com for test conditions.)



PA43--06,
PA43--07

Type	V _{DRM} / V _{RRM} Volts (V _{DRM} = V _{RRM} + 100V)	I _{T(av)} /T _C Amperes/°C (180° sin)	I _{T(RMS)} Amperes (180° sin)	EUROPEAN		NORTH AMERICAN		V _{FM} /I _{FM} Volts/Amperes (T _J = 25°C)	V _{TO} Volts (T _{J(max)})	R _T mΩ (T _{J(max)})	di/dt Amperes/μsec (Non-Repulsive)	dV/dt Volts/μsec	R _{th(j-c)} °C/W	R _{th(c-s)} °C/W	T _{J(max)} °C	Outline Drawings	
				I _{TSM} Amperes (10ms, T _{J(max)} , No V _{RRM} Reapplied)	i ² t A ² sec (10ms, T _{J(max)} , No V _{RRM} Reapplied)	I _{TSM} Amperes (8.3ms, T _{J(max)} , 100% V _{RRM} Reapplied)	i ² t A ² sec (8.3ms, T _{J(max)} , 100% V _{RRM} Reapplied)									Number	Page
AC Switches																	
●PA43--06	1300 - 2400	600 / 81	1330	40,350	8.14 x 10 ⁶	29,500	3.63 x 10 ⁶	1.75 / 3000	0.869	0.237	400	600	0.029	0.009	125	4	H-12
●PA43--07	600 - 1800	700 / 82	1550	54,750	14.9 x 10 ⁶	40,000	6.60 x 10 ⁶	1.30 / 3000	1.010	0.117	400	600	0.029	0.009	125	4	H-12

●For Optional Cathode & Gate Lead Kits, go to page H-3.

AC Switches

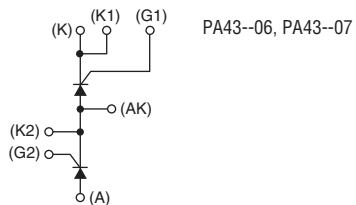

Thyristor / Diode Modules (Refer to device datasheets at www.pwr.x.com for test conditions.)



Type	V _{DRM} / V _{RRM} Volts (V _{RSM} = V _{RRM} + 100V)	I _{T(av)} /T _c Amperes/°C (180° sin)	I _{T(RMS)} Amperes (180° sin)	EUROPEAN		NORTH AMERICAN		V _{TM} /I _{TM} Volts/Amperes (T _{j(max)})	V _{T0} Volts (T _{j(max)})	R _T mΩ (T _{j(max)})	di/dt Amperes/μsec (Non-Repetitive)	dV/dt Volts/μsec	R _{th(j-c)} °C/W	R _{th(c-s)} °C/W	T _{j(max)} °C	Outline Drawings Number Page
				I _{TSM} Amperes (10ms, T _{j(max)} , No V _{RRM} Reapplied)	i ² t A ² sec (10ms, T _{j(max)} , No V _{RRM} Reapplied)	I _{TSM} Amperes (8.3ms, T _{j(max)} , 100% V _{RRM} Reapplied)	i ² t A ² sec (8.3ms, T _{j(max)} , 100% V _{RRM} Reapplied)									
●CD42--90B, CD47--90B	800 – 1800	90 / 87	140	1,785	15,910	1,570	10,270	1.10 / 100	0.80	2.40	150	500	0.135	0.1	125	1 H-11
●CD42--90C, CD47--90C	800 – 1800	90 / 85	141	2,200	24,200	1,600	10,760	1.70 / 270 (25°C)	0.80	3.01	TBD	800	0.28	0.15	125	12 H-15
●CD62--15B	800 – 1800	160 / 85	250	4,870	119,000	4,300	76,700	0.99 / 100 (25°C)	0.80	1.67	300	1000	0.08	0.05	125	2 H-11
●CD62--15C, CD67--15C	800 – 1800	150 / 86	235	5,940	176,415	4,340	78,470	1.70 / 480 (25°C)	0.80	1.69	TBD	800	0.17	0.08	125	13 H-15
●CD62--15C, CD67--15C	2000 – 2500	150 / 83	235	4,950	122,510	3,615	54,490	2.20 / 480 (25°C)	1.10	1.96	TBD	800	0.17	0.08	125	13 H-15
◆●ND42--21, ND47--21	600 – 2000	210 / 92	330	13,200	871,200	8,800	320,000	1.30 / 625	0.813	0.810	800	500	0.07	0.03	130	5 H-12
◆●ND42--25, ND47--25	600 – 1600	250 / 89	393	13,200	871,200	8,800	322,000	1.20 / 625	0.819	0.589	800	500	0.07	0.03	130	5 H-12
◆●ND421825, ND471825	1800	250 / 84	393	13,200	871,200	8,800	322,000	1.36 / 625	0.877	0.731	800	500	0.07	0.03	130	5 H-12
◆●LD42--43, LD47--43	1800 – 2200	510 / 70	800	12,000	0.72 x 10 ⁶	12,000	0.82 x 10 ⁶	1.77 / 1500	0.88	0.66	200	1000	0.0325	0.01	130	6 H-12
◆●LD42--50, LD47--50	600 – 1600	500 / 86	900	25,500	3.2 x 10 ⁶	17,000	1.20 x 10 ⁶	1.29 / 1500	0.81	0.32	200	1000	0.0325	0.01	130	6 H-12
◆●LD421850, LD471850	1800	500 / 84	900	25,500	3.2 x 10 ⁶	17,000	1.20 x 10 ⁶	1.36 / 1500	0.916	0.280	200	1000	0.0325	0.01	130	6 H-12
◆●LD82--24	3600 – 4000	240 / 74	377	7,525	236,000	5,500	126,000	3.5 / 1000 (25°C)	1.563	2.141	TBD	1000	0.0325	0.065	125	6 H-12
●PD42--07, PD47--07	600 – 1800	700 / 82	1100	60,000	18.0 x 10 ⁶	40,000	6.60 x 10 ⁶	1.30 / 3000	0.703	0.184	400	200	0.029	0.009	125	4 H-12
●PD42--06, PD47--06	2000 – 2400	600 / 81	942	44,250	9.7 x 10 ⁶	29,500	3.63 x 10 ⁶	1.60 / 3000	0.869	0.237	400	200	0.029	0.009	125	4 H-12

◆For Optional Hardware go to Page H-3.

●For Optional Cathode & Gate Lead Kits, go to page H-3.

Thyristor 1, Diode 2 Modules

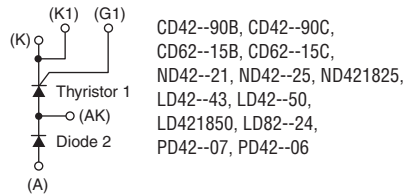

Diode 1, Thyristor 2 Modules

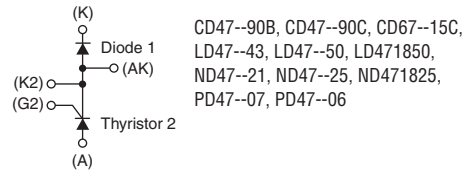

Thyristor / Diodes (POW-R-BRIKs™) (Refer to device datasheets at www.pwr.com for test conditions.)

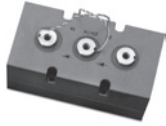

Type	V_{DRM} / V_{RRM} Volts ($V_{RSM} = V_{RRM} + 100V$)	$I_T(av)/T_c$ Amperes/°C ($180^\circ \sin$)	Maximim Power Dissipation (Watts)	E1 - I_{TSM}/I_{FSM} Amperes ($180^\circ \sin$)	E2 - I_{TSM}/I_{FSM} Amperes ($180^\circ \sin$)	Gate V_{gt} Volts	Gate I_{gt} mAmperes	di/dt Amperes/ μ sec (Non-Repettive)	dV/dt Volts/ μ sec	$R_{th(j-c)}$ °C/W (Per Module)	$R_{th(c-s)}$ °C/W (Per Module)	$R_{th(c-a)}$ °C/W (Per Module)	$T_{j(max)}$ °C	Outline Drawings Number Page
Diode / Diode Modules														
P1Z7AAR700W_	2200 – 3000	355 / 105	1125	7,000	7,000	—	—	—	—	0.04	0.010	0.10	150	7 H-13
P1Z8ABR800W_	1200 – 2200	435 / 105	1125	9,000	9,000	—	—	—	—	0.04	0.010	0.10	150	7 H-13
P1Z9AAR900W_	2200 – 3000	590 / 105	1500	16,000	16,000	—	—	—	—	0.03	0.008	0.08	150	7 H-13
P1Z9ACR900W_	800 - 1200	740 / 105	1500	30,000	30,000	—	—	—	—	0.03	0.008	0.08	150	7 H-13
P1Z9ADR900W_	600	800 / 110	1330	50,000	50,000	—	—	—	—	0.03	0.008	0.08	150	7 H-13
P1ZAADDA00W_	3600 - 5000	985 / 80	—	24,000	24,000	—	—	—	—	0.024	0.007	0.08	150	7 H-13
P1ZAABRA00W_	2200 - 3000	1270 / 80	—	—	—	—	—	—	—	0.03	0.008	0.08	150	7 H-13
P1ZAACRA00W_	1800 - 2200	1420 / 80	—	—	—	—	—	—	—	0.03	0.008	0.08	150	7 H-13
P1ZAADRA00W_	1200 - 1800	1585 / 80	—	—	—	—	—	—	—	0.03	0.008	0.08	150	7 H-13
Half Controlled SCR / Diode Modules														
P2Z7ABB700W_	1600 – 2200	380 / 85	1100	9,000	9,000	3	150	600	300	0.04	0.010	0.10	130	7 H-13
P2Z7ACB700W_	1200 – 1600	395 / 85	1100	10,000	14,000	3	150	600	300	0.04	0.010	0.10	130	7 H-13
P2Z9AAA900W_	2000 – 3000	430 / 85	1325	15,000	16,000	3	200	600	300	0.03	0.008	0.08	125	7 H-13
P2Z9ABA900W_	1600 - 2000	520 / 85	1465	17,000	16,000	3	200	600	300	0.03	0.008	0.08	130	7 H-13
P2Z9ACA900W_	1200 - 1600	590 / 85	1465	25,000	16,000	3	200	600	300	0.03	0.008	0.08	130	7 H-13
P2ZAABA00W_	1200 - 2200	880 / 80	—	—	—	3	200	400	300	0.03	0.008	0.08	125	7 H-13
Full Control SCR / SCR Modules														
P3Z8AAT800W_	2200 – 3000	300 / 85	1095	9,000	9,000	3	150	600	300	0.04	0.010	0.10	130	7 H-13
P3Z7ABT700W_	1600 – 2200	345 / 85	1095	9,000	9,000	3	150	600	300	0.04	0.010	0.10	130	7 H-13
P3Z9AAT900W_	2000 - 3000	355 / 85	1295	15,000	15,000	3	200	600	300	0.03	0.008	0.08	125	7 H-13
P3Z7ACT700W_	1200 – 1600	375 / 85	1095	10,000	10,000	3	150	600	300	0.04	0.010	0.10	130	7 H-13
P3Z8ABT800W_	1400 - 2200	390 / 85	1095	12,000	12,000	3	150	600	300	0.04	0.010	0.10	130	7 H-13
P3Z8ACT800W_	1200 - 1400	450 / 85	1095	15,000	15,000	3	150	600	300	0.04	0.010	0.10	130	7 H-13
P3Z9ABT900W_	1600 - 2000	470 / 85	1460	17,000	17,000	3	200	600	300	0.03	0.008	0.08	130	7 H-13
P3Z9ACT900W_	1200 - 1600	600 / 85	1460	25,000	25,000	3	200	600	300	0.03	0.008	0.08	130	7 H-13
P3ZAABA00W_	1200 - 2200	880 / 80	—	—	—	3	200	400	300	0.03	0.008	0.08	125	7 H-13
Half Controlled Diode / SCR Modules														
P7Z7ABB700W_	1600 – 2200	380 / 85	1100	9,000	9,000	3	150	600	300	0.04	0.010	0.10	130	7 H-13
P7Z7ABC700W_	1200 – 1600	395 / 85	1100	14,000	10,000	3	150	600	300	0.04	0.010	0.10	130	7 H-13
P7Z9AAA900W_	2000 – 3000	430 / 85	1325	16,000	15,000	3	200	600	300	0.03	0.008	0.08	125	7 H-13
P7Z9AAB900W_	1600 - 2000	520 / 85	1465	16,000	17,000	3	200	600	300	0.03	0.008	0.08	130	7 H-13
P7Z9AAC900W_	1200 - 1600	590 / 85	1465	16,000	25,000	3	200	600	300	0.03	0.008	0.08	130	7 H-13
P7ZAABA00W_	1200 - 2200	880 / 80	—	—	—	3	200	400	300	0.03	0.008	0.08	125	7 H-13

Diode / Diode

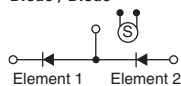

- P1Z7AAR700W_
- P1Z8ABR800W_
- P1Z9AAR900W_
- P1Z9ACR900W_
- P1Z9ADR900W_
- P1ZAADDA00W_
- P1ZAABRA00W_
- P1ZAACRA00W_
- P1ZAADRA00W_

SCR / Diode

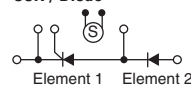

- P2Z7ABB700W_
- P2Z7ACB700W_
- P2Z9AAA900W_
- P2Z9ABA900W_
- P2Z9ACA900W_
- P2ZAABA00W_

SCR / SCR

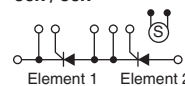

- P3Z7ABT700W_
- P3Z7ACT700W_
- P3Z8AAT800W_
- P3Z8ABT800W_
- P3Z8ACT800W_
- P3Z9AAT900W_
- P3Z9ABT900W_
- P3Z9ACT900W_
- P3ZAABA00W_

Diode / SCR



- P7Z7ABB700W_
- P7Z7ABC700W_
- P7Z9AAA900W_
- P7Z9AAB900W_
- P7Z9AAC900W_
- P7ZAABA00W_

1 CD42--90B, CD43--90B, CD47--90B

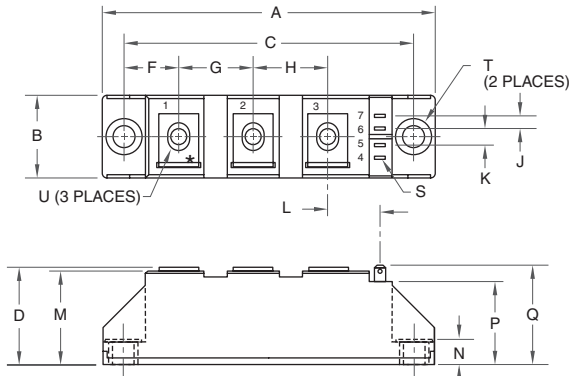

Dim.	Inches	Millimeters
A	3.66	93.0
B	0.79	20.0
C	3.15	80.0
D	1.18	30.0
F	0.61	15.5
G	0.79	20.0
H	0.79	20.0
J	0.16	4.0
K	0.22	5.7

Dim.	Inches	Millimeters
L	0.59	15.5
M	1.10	28.0
N	0.31	8.0
P	0.94	24.0
Q	1.16	29.4
S	0.11 x 0.03	2.8 x 0.8
T	0.25	6.4
U	M5 Metric	M5

2 CD61, CD62--16B, CD63--15B, CD67, CS61*

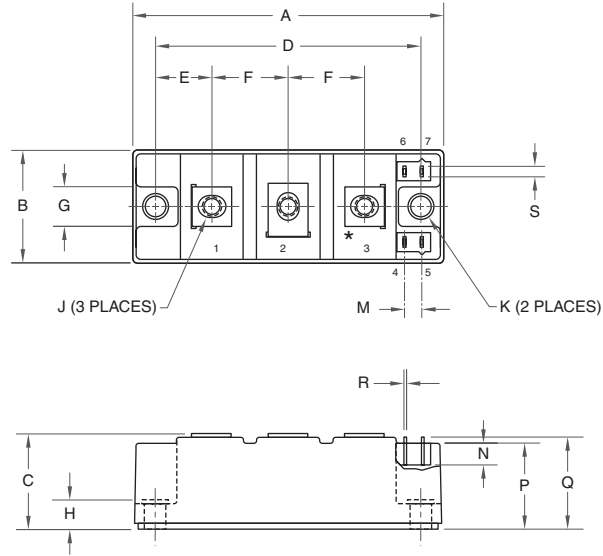

Dim.	Inches	Millimeters
A	3.70	94.0
B	1.34	34.0
C	1.18	30.0
D	3.15	80.0
E	0.67	17.0
F	0.91	23.0
G	0.51	13.0
H	0.35	8.3

Dim.	Inches	Millimeters
J	M6 Metric	M6
K	0.26	6.4
M	0.02	5.0*
N	0.28	6.0*
P	1.06	27.0*
Q	1.14	29.0*
R	0.03	0.8*
S	0.11	2.8*

*Does not apply to CD61--16B, and CS61--16B.

3 LS41, LS43, LS81, LS83

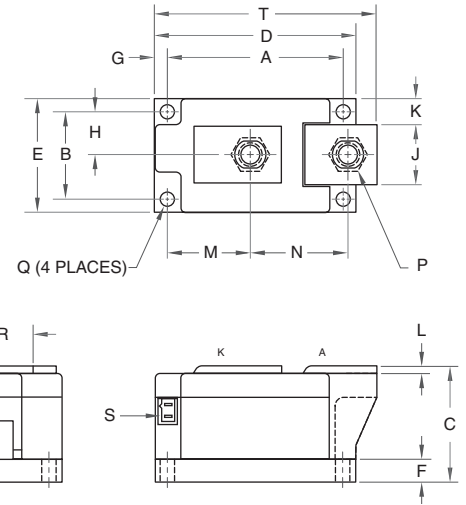

Dim.	Inches	Millimeters
A	3.15	80.0
B	1.50	38.0
C	2.05	52.1
D	3.62	92.0
E	1.97	50.0
F	0.39	9.9
G	0.24	6.1
H	0.75	19.0
J	0.99	25.1

Dim.	Inches	Millimeters
K	0.48	12.2
L	0.12	3.1
M	1.45	36.8
N	1.76	44.77
P	M10 Metric	M10
Q	9.25 Dia.	6.35 Dia.
S	0.110 x 0.032	2.5 x 0.8*
T	3.99	101.3

*Does not apply to LS41--60.

4 PA43, PD41, PD42, PD43, PD47, PS41, PS415014, PS43

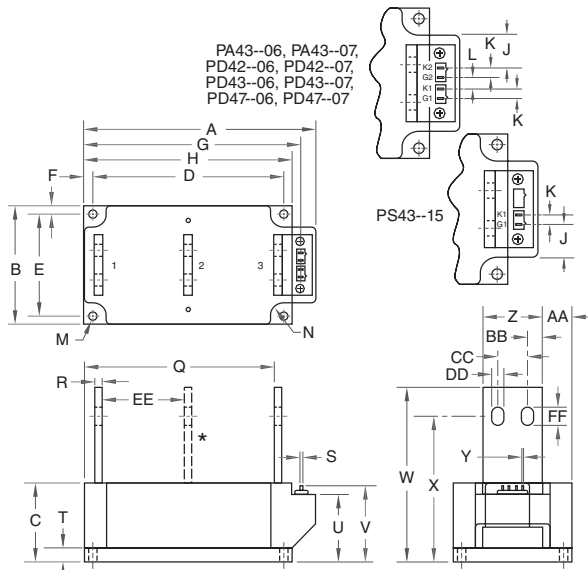

Dim.	Inches	Millimeters	Dim.	Inches	Millimeters
A	7.80	198.1	R	0.19	4.8
B	4.0	101.6	S	0.11	2.8*
C	2.68	68.1	T	0.48	12.2
D	6.44	163.6	U	2.28	58.0
E	3.44	87.4	V	2.54	64.5
F	0.28	7.1	W	4.93	125.2
G	7.31	185.7	X	3.81	96.8
H	7.0	177.8	Y	0.03	0.8*
J	1.65	42.0*	Z	2.0	50.8
K	0.21	5.3*	AA	1.0	25.4
L	0.28	7.1*	BB	0.5	12.7
M	0.281	7.1	CC	1.0	25.4
N	0.45	11.4	DD	0.406	10.3
P	0.54	13.7	EE	2.87	72.9*
Q	5.93	150.6	FF	0.66	16.8

*Does not apply to PD41--11, PS41--25.

5 ND41, ND42, ND43, ND47, NS41

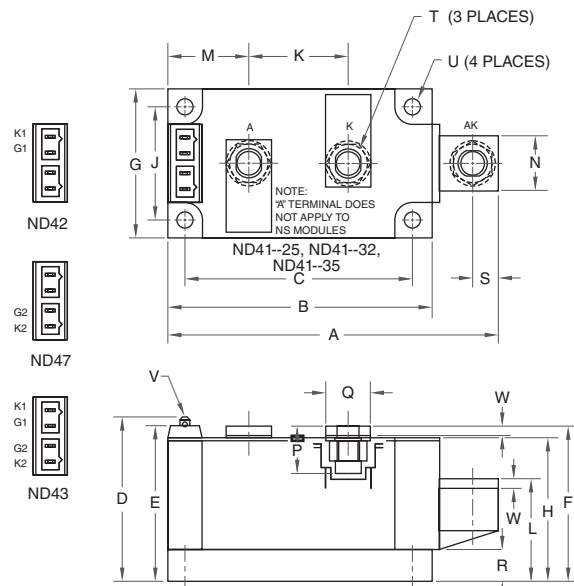

Dim.	Inches	Millimeters	Dim.	Inches	Millimeters
A	4.57	116.0	M	1.122	28.5
B	3.66	93.0	N	0.71	18.0
C	3.15	80.0	P	0.57	14.5
D	2.17	55.1	Q	0.625	15.9
E	2.06	52.3	R	0.394	10.0
F	2.07	52.0	S	0.35	8.9
G	1.97	50.0	T	M8 Metric	M8
H	1.90	48.3	U	0.25 Dia.	6.35 Dia.
J	1.50	38.1	V	0.110 x 0.032	2.8 x 0.8*
K	1.36	35.0	W	0.12	3.0
L	1.26	32.0			

*Does not apply to ND41--26, ND41--32, and ND41--35.

6 LD41, LD42, LD43, LD47, LD81, LD82, LD83

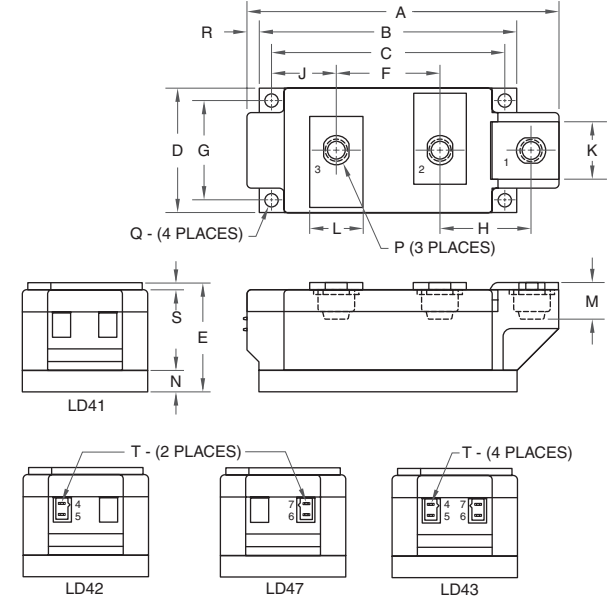

Dim.	Inches	Millimeters	Dim.	Inches	Millimeters
A	5.91	150.0	K	1.10	28.0
B	4.88	124.0	L	1.00	25.4
C	4.41	112.0	M	0.69	17.5
D	2.36	60.0	N	0.39	10.0
E	2.05	52.0	P	M10 Metric	M10
F	1.97	50.0	Q	0.26 Dia.	6.5 Dia.
G	1.89	48.0	R	0.24	6.0
H	1.73	44.0	S	0.12	3.0
J	1.22	31.0	T	0.110 x 0.32	2.5 x 0.8*

*Does not apply to LD41--60.

7 P1Z7, P1Z8, P1Z9, P1ZA, P2Z7, P2Z9, P2ZA, P3Z7, P3Z8, P3Z9, P3ZA, P7Z7, P7Z9, P7ZA

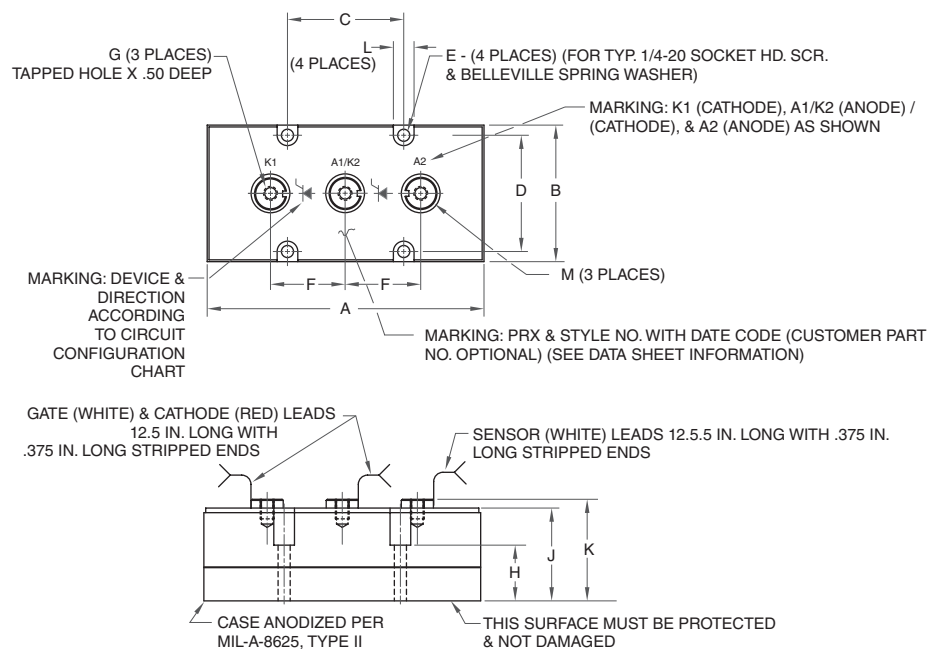

ZAA Modules

Dim.	Inches	Millimeters
A	8.5	215.9
B	4.33	109.98
C	3.15	80.01
D	3.78	96.01
E	0.328 Dia.	8.33 Dia.
F	2.34±0.03	59.4±0.8
G	7/16-14 UNC-2B	
H	2.14	54.36
J	3.15	80.01
K	3.38	85.85
L	0.56	14.22
M	1.12	28.45

Z7A / Z8A Modules

Dim.	Inches	Millimeters
A	6.30	153.16
B	3.03	76.96
C	3.15	80.01
D	2.47	62.73
E	0.328 Dia.	8.33 Dia.
F	1.83±0.03	46.48±0.8
G	5/16-18 UNC-2B	
H	1.27	32.25
J	2.09	53.08
K	2.25	57.15
L	0.58	14.22

Z9A Modules

Dim.	Inches	Millimeters
A	7.50	190.5
B	3.70	93.98
C	3.15	80.01
D	3.15	80.01
E	0.328 Dia.	8.33 Dia.
F	2.03±0.03	51.56±0.8
G	3/8-16 UNC-2B	
H	1.51	38.35
J	2.52	64.0
K	2.75	69.85
L	0.56	14.22

8 CD41--99C, CD41--99D, CD411699D

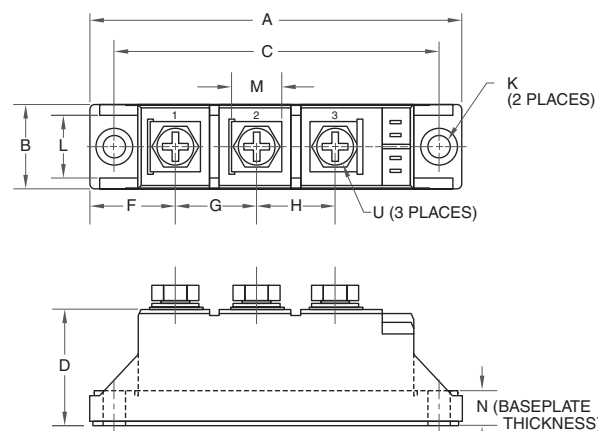

Dim.	Inches	Millimeters
A	3.62	92.0
B	0.83	21.0
C	3.15	80.0
D	1.18	30.0
F	0.83	21.0
G	0.79	20.0

Dim.	Inches	Millimeters
H	0.79	20.0
K	0.24 Dia.	6.2 Dia.
L	0.63	16.0
M	0.51	13.0
U	M5 Metric	M5

CD41--99C

Dim.	Inches	Millimeters
N	0.33	8.5

CD41--99D

Dim.	Inches	Millimeters
N	0.24	6.1

9 CD43--90C, CD43--99C

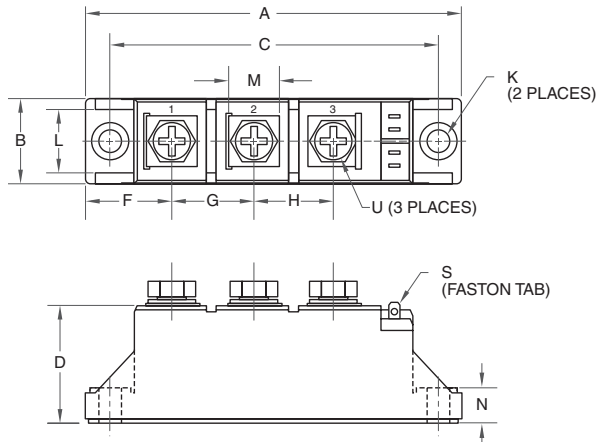

Dim.	Inches	Millimeters
A	3.62	92.0
B	0.83	21.0
C	3.15	80.0
D	1.18	30.0
F	0.83	21.0
G	0.79	20.0
H	0.79	20.0

Dim.	Inches	Millimeters
K	0.24	6.2
L	0.63	16.0
M	0.51	13.0
N	0.33	8.5
S	0.11 x 0.02	2.8 x 0.5
U	M5 Metric	M5

10 CD61--16C, CD61--20C, CS61--16C

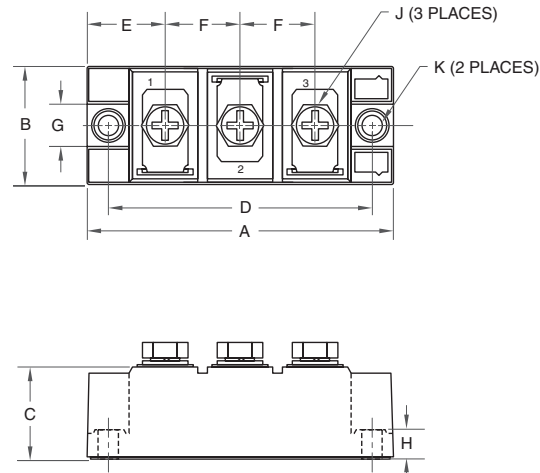

Dim.	Inches	Millimeters
A	3.70	94.0
B	1.34	34.0
C	1.15	29.2
D	3.15	80.0
E	0.94	24.0

Dim.	Inches	Millimeters
F	0.91	23.0
G	0.51	13.0
H	0.35	9.0
J	M6 Metric	M6
K	0.24 Dia.	6.2 Dia.

11 CD63--15C

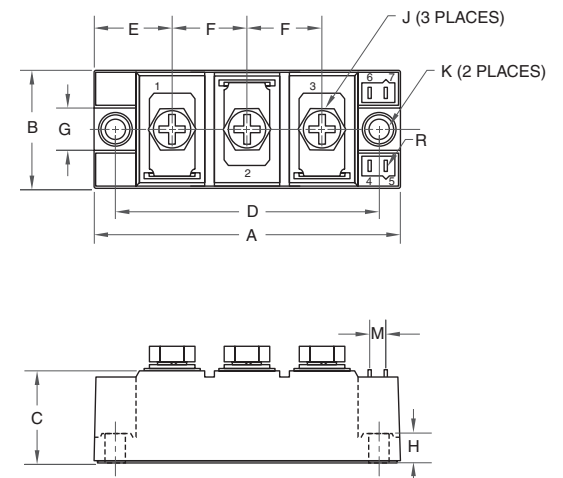

Dim.	Inches	Millimeters
A	3.70	94.0
B	1.34	34.0
C	1.15	29.2
D	3.15	80.0
E	0.94	24.0
F	0.91	23.0

Dim.	Inches	Millimeters
G	0.51	13.0
H	0.35	9.0
J	M6 Metric	M6
K	0.24 Dia.	6.2 Dia.
M	0.19	4.9
R	0.03 x 0.11	2.8 x 0.8

12 CD42--90C, CD47--90C

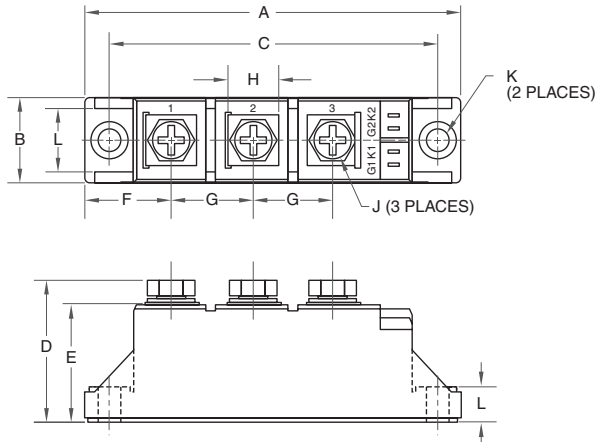

Dim.	Inches	Millimeters
A	3.62	92.0
B	0.83	21.0
C	3.15	80.0
D	1.38	35.0
E	1.18	30.0

Dim.	Inches	Millimeters
F	0.83	21.0
G	0.79	20.0
H	0.51	13.0
J	M5 Metric	M5
K	0.24 Dia.	6.2 Dia.

13 CD62--15C, CD67--15C

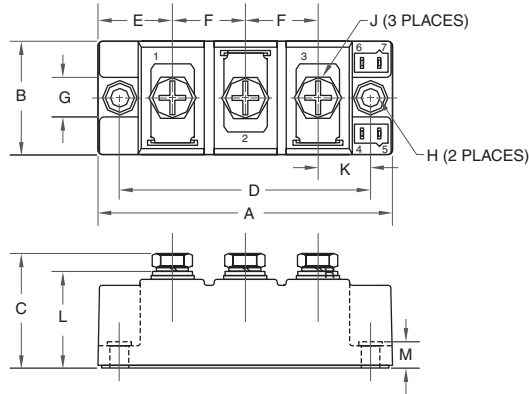

Dim.	Inches	Millimeters
A	3.70	94.0
B	1.34	34.0
C	1.42	36.0
D	3.15	80.0
E	0.94	24.0
F	0.91	23.0

Dim.	Inches	Millimeters
G	0.51	13.0
H	0.24 Dia.	6.2 Dia.
J	M6 Metric	M6
K	0.67	17.0
L	1.15	29.2
M	0.35	9.0

14 Lead Kits MR, MQ

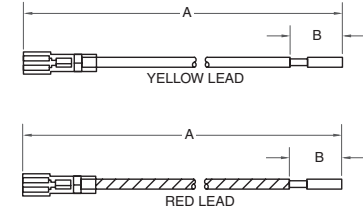

1. WIRE COMPOSITION:
AWG 22, TINNED COPPER STRAND WIRE WITH ETEF INSULATION RATED TO 125°C
2. LEAD COLOR:
RED (CATHODE) AND YELLOW (GATE), BOTH WITH INSULATED TERMINALS
3. RECEPTACLES:
FEMALE TERMINAL WITH NYLON INSULATOR THAT FITS .11 x .03 IN. BLADES

MQ KIT: TWO RED & TWO YELLOW LEADS / MODULE

MR KIT: ONE RED & ONE YELLOW LEAD / MODULE

Dim.	Inches	Millimeters
A	0.46	11.80
B	0.01	0.26

15 Lead Kits NK, NL, NM

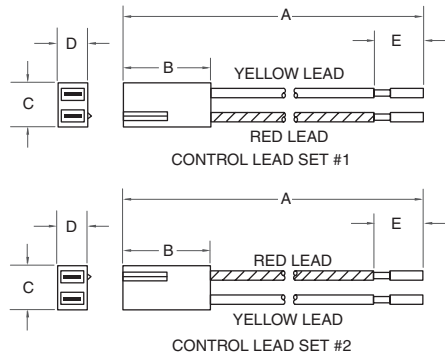

1. WIRE COMPOSITION:
AWG 22, TINNED COPPER STRAND WIRE WITH ETEF INSULATION RATED TO 125°C
2. LEAD COLOR:
RED (CATHODE) AND YELLOW (GATE). RED LEAD IS POSITIONED NEXT TO KEY ON BLACK POLARIZED HOUSING.
3. RECEPTACLES:
FEMALE TERMINAL WITH LOCKING TAB FITS .11 x .03 IN. BLADES

NK KIT: LEAD SET 1 & LEAD SET 2 - ONE EACH / MODULE

NL KIT: LEAD SET 1 - ONE / MODULE

NM KIT: LEAD SET 2 - ONE / MODULE

Dim.	Inches	Millimeters	Dim.	Inches	Millimeters
A	0.54	13.80	D	0.009	0.23
B	0.03	0.79	E	0.01	0.26
C	0.015	0.39			

16 QRD4518001, QRD6516001

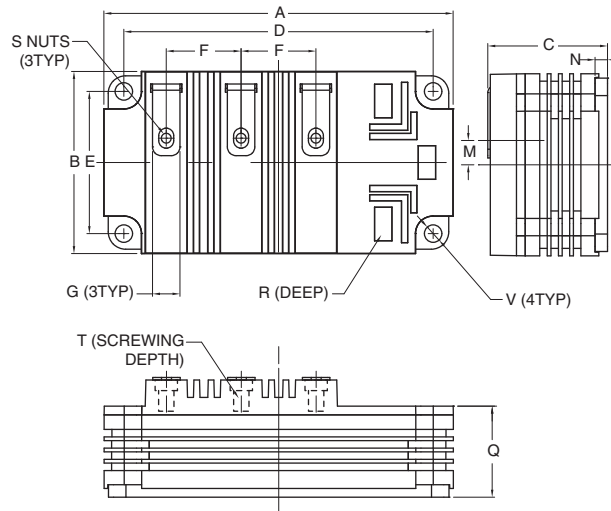

Dim.	Inches	Millimeters	Dim.	Inches	Millimeters
A	5.51	140.0	M	0.38	9.75
B	2.87	73.0	N	0.20	5.0
C	1.89	48.0	Q	1.44	36.5
D	4.88±0.01	124.0±0.25	R	0.16	4.0
E	2.24±0.01	57.0±0.25	S	M6 Metric	M6
F	1.18	30.0	T	0.63 Min.	16.0 Min.
G	0.43	11.0	V	0.28 Dia.	7.0 Dia.

FAST RECOVERY DIODE MODULES

Fast Recovery Modules

Applications Include:

- Motor Controls
- Power Supplies
- Switching Power Supplies
- Transportation
- Welding

Circuit Configurations:

- Single
- Dual
- Common Anode
- Common Cathode

TABLE OF CONTENTS

Numbering System	I-2
Single Fast Recovery Diodes	I-2
Dual Fast Recovery Diodes	I-4
Common Anode Fast Recovery Diodes	I-6
Common Cathode Fast Recovery Diodes	I-6
Outline Drawings	I-7

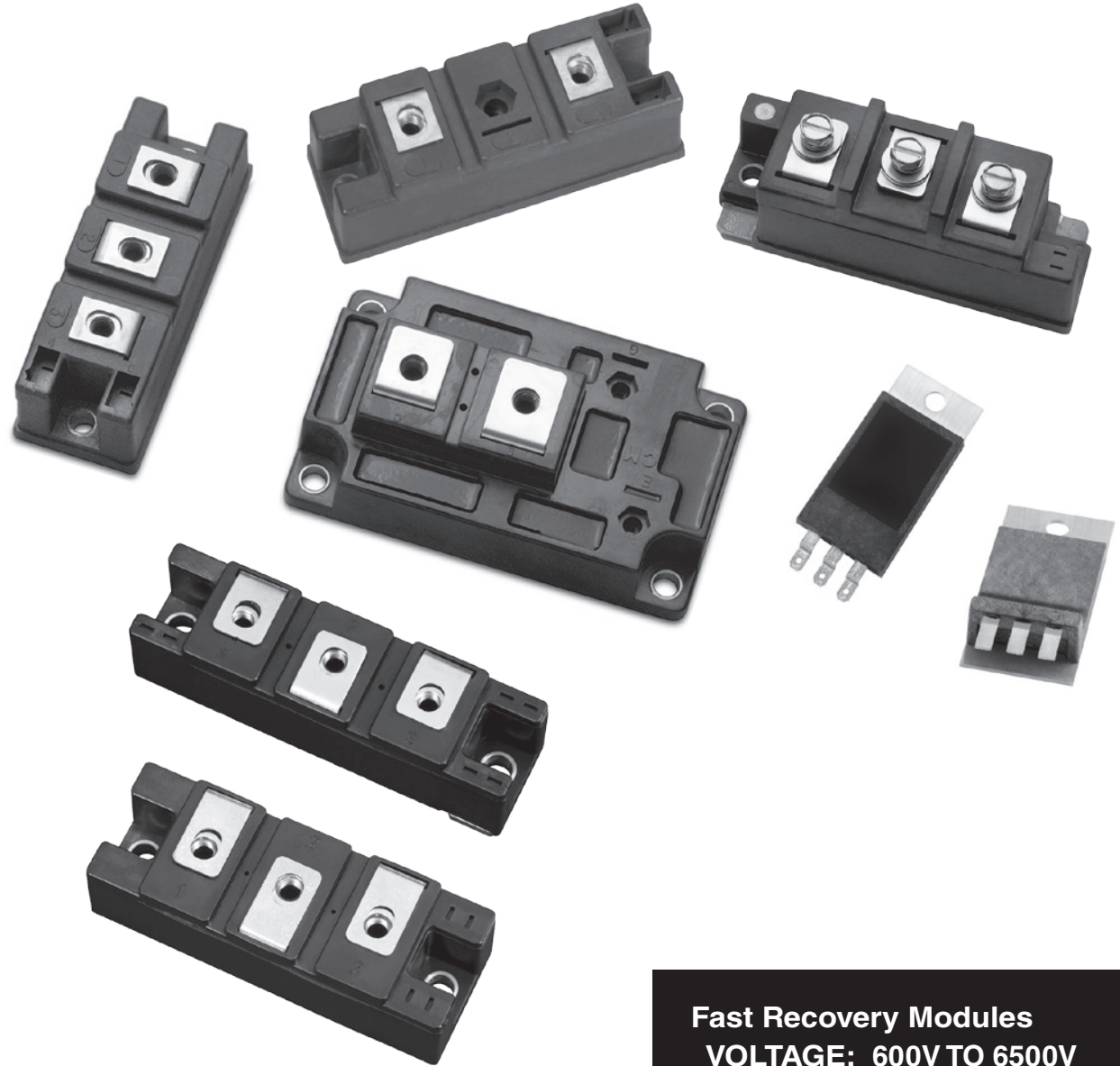

Fast Recovery Modules
VOLTAGE: 600V TO 6500V
CURRENT: 33A TO 1800A

Single Fast Recovery Diodes (Refer to device datasheets at www.pwr.com for test conditions.)



Type	V _{RRM} Volts (V _{RSM} = V _{RRM} + 100V)	I _{F(av)} /T _C Amperes/°C (180° sin)	NORTH AMERICAN		V _{FM} /I _{FM} Volts/Amperes (T _J = 25°C)	t _{rr}			R _{th(j-c)} °C/W	R _{th(c-s)} °C/W	T _{J(max)} °C	Weight	Outline Drawings	
			I _{FSM} Amperes (8.3ms, T _{J(max)} , 100% V _{RRM} Reapplied)	i ² t A ² sec (8.3ms, T _{J(max)} , 100% V _{RRM} Reapplied)		t _{rr} ns	at I _F Amperes	di/dt Amperes/μs					Number	Page
Single Fast Diodes														
QRS0620T30	600	66 / 80	1670	11,620	2.8 / 200	110	200	-400	0.35	0.04	150	220	5	I-8
QRS0640T30	600	128 / 80	2400	24,000	2.8 / 400	110	400	-800	0.18	0.04	150	220	5	I-8
QRS0660T30	600	194 / 80	3600	54,000	2.8 / 600	110	600	-1200	0.12	0.04	150	220	5	I-8
QRS0680T30	600	267 / 80	4800	96,000	2.8 / 800	110	800	-1600	0.09	0.04	150	220	5	I-8
QRS061K001	600	420 / 80	8350	290,000	2.8 / 1000	150	1000	-2000	0.07	0.04	150	400	10	I-10
QRS1220T30	1200	88 / 80	1670	11,620	3.5 / 200	250	200	-400	0.18	0.04	150	220	5	I-8
QRS1240T30	1200	180 / 80	3350	46,760	3.5 / 400	250	400	-800	0.09	0.04	150	220	5	I-8
QRS1260T30	1200	276 / 80	5000	104,100	3.5 / 600	250	600	-1200	0.06	0.04	150	220	5	I-8
QRS171D001	1700	700 / 80	2400	24,000	2.5 / 700	2000	1200	-2400	0.04	0.04	150	400	14	I-11
QRS4506001	4500	60 / 100	120	1900	5.6 / 60	230	67	-800	0.15	0.10	150	21	16	I-12
QRS4506002	4500	60 / 100	120	1900	5.6 / 60	230	67	-800	0.15	0.10	150	20	17	I-12
QRS6503002	6500	33 / 100	TBD	TBD	4.0 / 33	1000	33	-110	0.15	0.10	150	20	17	I-12
QRS6505002	6500	50 / 100	TBD	TBD	3.2 / 50	1700	50	-230	0.14	0.10	150	20	17	I-12

Single Fast Diodes

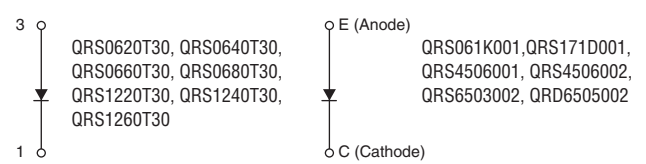

Numbering System

FAST RECOVERY DIODE MODULES

RM400HA-34S is a 400A, 1700V Single Switch Fast Recovery Diode Module

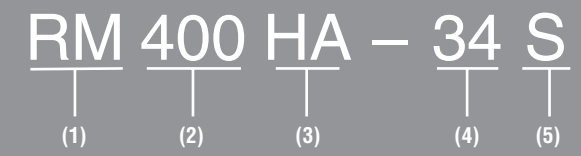

- (1) Type Number:
RM = Rectifier Module
- (2) Current Rating
- (3) Package Style:
DB = Dual, Standard Package
DG = Dual, High Isolation
DY = Dual Switch
HA = Single Switch
HC = Single, AISiC Baseplate
HE = Single, Small Package
- (4) Voltage Rating (x 50):
12 = 600V
24 = 1200V
34 = 1700V
66 = 3300V
90 = 4500V
130 = 6500V
- (5) Factory Designation

QRD0640R30 is a 600V, 400A Dual Switch RoHs Compliant Fast Recovery Module



- (1) Product Line
- (2) Type Number:
R = Rectifier
- (3) Package Style:
S = Single Switch
D = Dual Switch
C = Common Cathode
F = Common Anode
J = Inverse Configuration
- (4) Voltage Rating (x 100)
- (5) Current (x 10)
- (6) Serial Designation
R30 = 30mm Terminal Height, RoHS Compliant
T30 = 30mm Terminal Height, Not RoHS Compliant
001 = Special Designation

Single Fast Recovery Diodes (Refer to device datasheets at www.pwr.x.com for test conditions.)



RM400HA-34S

Type	V _{RRM} Volts (V _{RSM} = V _{RRM} + 100V)	I _{F(av)} /T _c Amperes/°C (180° sin)	EUROPEAN		NORTH AMERICAN		V _{FM} /I _{FM} Volts/Amperes (25°C)	R _{th(j-c)} °C/W	R _{th(c-s)} °C/W	T _{j(max)} °C	T _{rr} 150°C ns	T _{rr} 25°C ns	Outline Drawings		
			I _{FSM} Amperes (10ms, T _{j(max)} , No V _{RRM} Reapplied)	i ² t A ² sec (10ms, T _{j(max)} , No V _{RRM} Reapplied)	I _{FSM} Amperes (8.3ms, T _{j(max)} , 100% V _{RRM} Reapplied)	i ² t A ² sec (8.3ms, T _{j(max)} , 100% V _{RRM} Reapplied)							Number	Page	
Single Fast Diode															
RM400HA-34S	1700	400 / 90	—	—	8000	260,000	2.5 / 400	0.08	0.04	150	500	—	2	1-7	

Type	V _{RRM} Volts (V _{RSM} = V _{RRM} + 100V)	I _{F(av)} Amperes (180° sin)	NORTH AMERICAN		V _{FM} /I _{FM} Volts/Amperes (25°C)	R _{th(j-c)} °C/W	R _{th(c-s)} °C/W	T _{j(max)} °C	T _{rr} 150°C ns	T _{rr} 25°C ns	Outline Drawings	
			I _{FSM} Amperes (8.3ms, T _{j(max)} , 100% V _{RRM} Reapplied)	i ² t A ² sec (8.3ms, T _{j(max)} , 100% V _{RRM} Reapplied)							Number	Page
Single High Voltage Fast Diodes												
RM1800HE-34S	1700	1800	9600	384,000	2.9 / 1800	0.022	0.017	150	1800	—	3	1-7
RM1200HE-66S	3300	1200	9600	384,000	3.2 / 1200	0.02	0.015	150	1400 (at 125°C)	—	3	1-7
RM1500HE-66F	3300	1500	12000	598,000	2.6 / 1500	0.0145	0.015	150	900	—	18	1-12
RM600HE-90S	4500	600	4800	95,600	4.8 / 600	0.039	0.015	150	900 (at 125°C)	—	3	1-7
RM900HC-90S	4500	900	7200	216,000	4.8 / 900	0.021	0.016	150	1000 (at 125°C)	—	4	1-8

Single Fast Diodes

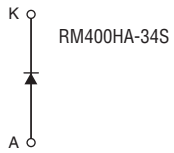

Single High Voltage Fast Diodes

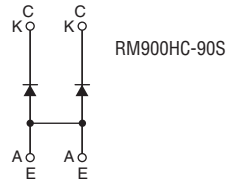
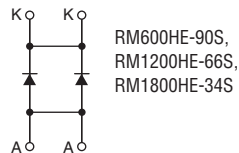
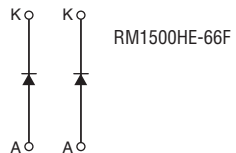

Dual Fast Recovery Diodes (Refer to device datasheets at www.pwr.com for test conditions.)



RM400DY-24S



QRD0620R30,
QRD1220R30



QRD0630R30,
QRD0640R30,
QRD1230R30,
QRD1240R30



QRD3310001,
QRD3310002,
QRD3310003,
QRD3310005

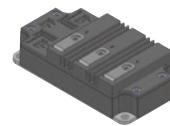

QRD3320004

Type	V _{RRM} Volts (V _{RSM} = V _{RRM} + 100V)	I _{F(av)} /T _c Amperes/°C (180° sin)	EUROPEAN		NORTH AMERICAN		V _{FM} /I _{FM} Volts/Amperes (25°C)	R _{th(j-c)} °C/W	R _{th(c-s)} °C/W	T _{j(max)} °C	T _{rr} 150°C ns	T _{rr} 25°C ns	Outline Drawings Number	Page
			I _{FSM} Amperes (10ms, T _{j(max)} , No V _{RRM} Reapplied)	i ² t A ² sec (10ms, T _{j(max)} , No V _{RRM} Reapplied)	I _{FSM} Amperes (8.3ms, T _{j(max)} , 100% V _{RRM} Reapplied)	i ² t A ² sec (8.3ms, T _{j(max)} , 100% V _{RRM} Reapplied)								
Dual Fast Recovery Diodes														
RM400DY-24S	1200	400	—	—	2000	16,600	2.6 / 400	—	0.018	150	290 (@125°C)	250	12	I-10
Dual High Voltage Fast Recovery Diodes														
RM1200DB-34S	1700	1200	—	42,700	—	180,300	2.1 / 1200	0.02	0.024	150	850 (@125°C)	—	13	I-11
RM400DY-66S	3300	400	3200	96,000	—	42,700	4.29 / 400	0.072	0.036	150	—	1200	6	I-8
RM600DY-66S	3300	600	4800	—	6400	96,000	4.55 / 600	0.048	0.024 Typ.	150	—	1200	6	I-8
RM1000DC-66F	3300	1000	—	—	20,800	440	2.2 / 1000	0.024	—	150	850	550	11	I-10
RM1200DB-66S	3300	1200	—	—	9600	384,000	2.8 / 1200	0.018	0.016	150	—	750	4	I-8
RM1500DC-66F	3300	1500	—	—	14,000	980,000	2.2 / 3000	0.016	0.0175	150	850	550	11	I-10
RM900DB-90S	4500	900	—	—	9.4	170,000	4.0 / 900	0.02	0.016	150	—	900	4	I-8

Type	V _{RRM} Volts (V _{RSM} = V _{RRM} + 100V)	I _{dc} /T _c Amperes/°C (180° sin)	NORTH AMERICAN		V _{FM} /I _{FM} Volts/Amperes (T _j = 25°C)	t _{rr}			R _{th(j-c)} °C/W	R _{th(c-s)} °C/W	T _{j(max)} °C	Weight	Outline Drawings Number	Page
			I _{FSM} Amperes (8.3ms, T _{j(max)} , 100% V _{RRM} Reapplied)	i ² t A ² sec (8.3ms, T _{j(max)} , 100% V _{RRM} Reapplied)		t _{rr} ns	at I _f Amperes	di/dt Amperes/μs						
Dual Fast Recovery Diodes														
QRD0620R30	600	140 / 80	TBD	TBD	2.3 / 150	120	100	TBD	0.205	0.2	150	150	1	I-7
QRD0630R30	600	210 / 80	TBD	TBD	2.2 / 150	120	150	TBD	0.137	0.2	150	180	8	I-9
QRD0640R30	600	280 / 80	TBD	TBD	2.2 / 200	120	200	TBD	0.103	0.2	150	180	8	I-9
QRD1220R30	1200	140 / 80	1700	12,000	3.2 / 100	150	100	TBD	0.15	0.2	150	150	1	I-7
QRD1230R30	1200	210 / 80	2550	27,000	3.2 / 150	150	150	TBD	0.1	0.2	150	180	8	I-9
QRD1240R30	1200	280 / 80	3400	48,000	3.2 / 200	150	200	TBD	0.075	0.2	150	180	8	I-9
QRD3310001	3300	86 / 80	TBD	TBD	4.3 / 100	1200	100	-200	0.12	0.05	150	250	9	I-9
QRD3310002	3300	60 / 80	TBD	TBD	4.3 / 100	1200	100	-200	0.2	0.05	150	250	9	I-9
QRD3310003*	3300	86 / 80	TBD	TBD	4.3 / 100	1200	100	-200	0.12	0.005	150	250	9	I-9
QRD3310005	3300	86 / 80	TBD	TBD	4.3 / 100	1200	100	-200	0.12	0.05	150	250	9	I-9
QRD3320004	3300	260 / 80	1900	TBD	3.0 / 200	500	165	TBD	0.096	0.018	150	800	15	I-11

*RoHS Compliant

Dual Fast Recovery Diodes

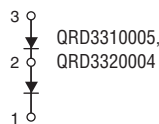
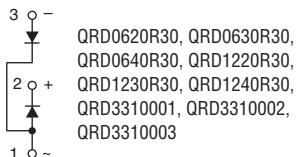
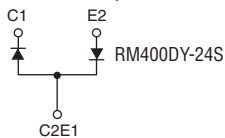

Dual High Voltage Fast Recovery Diodes

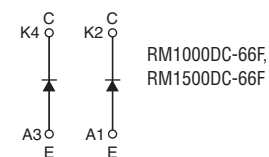
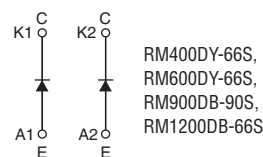
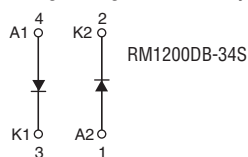

Dual Fast Recovery Diodes (Refer to device datasheets at www.pwr.x.com for test conditions.)



QRJ0620R30,
QRJ1220R30



QRJ0630R30,
QRJ0640R30,
QRJ1230R30,
QRJ1240R30

Type	V _{RRM} Volts (V _{RSM} = V _{RRM} + 100V)	I _{DC} /T _C Amperes/°C (180° sin)	NORTH AMERICAN		V _F M/I _F M Volts/Amperes (T _J = 25°C)	t _{rr}			R _{th(j-c)} °C/W	R _{th(c-s)} °C/W	T _{j(max)} °C	Weight	Outline Drawings	
			I _{FSM} Amperes (8.3ms, T _{j(max)} , 100% V _{RRM} Reapplied)	i ² t A ² sec (8.3ms, T _{j(max)} , 100% V _{RRM} Reapplied)		t _{rr} ns	at I _F Amperes	di/dt Amperes/μs					Number	Page
QRJ0620R30	600	140 / 80	TBD	TBD	2.3 / 150	120	100	TBD	0.205	0.2	150	150	1	I-7
QRJ0630R30	600	210 / 80	TBD	TBD	2.2 / 150	120	150	TBD	0.137	0.2	150	180	8	I-9
QRJ0640R30	600	280 / 80	TBD	TBD	2.2 / 200	120	200	TBD	0.103	0.2	150	180	8	I-9
QRJ1220R30	1200	140 / 80	1700	12,000	3.2 / 100	150	100	TBD	0.15	0.2	150	150	1	I-7
QRJ1230R30	1200	210 / 80	2550	27,000	3.2 / 150	150	150	TBD	0.1	0.2	150	180	8	I-9
QRJ1240R30	1200	280 / 80	3400	48,000	3.2 / 200	150	200	TBD	0.075	0.2	150	180	8	I-9

Type	V _{RRM} Volts (V _{RSM} = V _{RRM} + 100V)	I _{F(av)} Amperes (180° sin)	NORTH AMERICAN		V _F M/I _F M Volts/Amperes (25°C)	R _{th(j-c)} °C/W	R _{th(c-s)} °C/W	T _{j(max)} °C	T _{rr} 125°C ns	T _{rr} 25°C ns	Outline Drawings	
			I _{FSM} Amperes (8.3ms, T _{j(max)} , 100% V _{RRM} Reapplied)	i ² t A ² sec (8.3ms, T _{j(max)} , 100% V _{RRM} Reapplied)							Number	Page
RM400DG-66S	3300	400	3200	42,700	2.8 / 400	0.054	0.048	150	1,000	—	7	I-9
RM1200DG-66S	3300	1200	9600	384,000	2.8 / 1200	0.018	0.016	150	1,000	—	7	I-9
RM300DG-90S	4500	300	2400	24,000	4.8 / 300	0.066	0.048	150	1,000	700	7	I-9
RM400DG-90F	4500	400	3400	58,000	2.55 / 400	0.0585	0.048	150	900	700	7	I-9
RM800DG-90F	4500	800	6500	211,000	2.55 / 800	0.030	0.024	150	900	700	7	I-9
RM1200DG-90F	4500	1200	9800	480,000	2.55 / 1200	0.020	0.016	150	900	700	7	I-9
RM200DG-130S	6500	200	1600	11,000	4.0 / 200	0.066	0.048	150	1,000	—	7	I-9
RM250DG-130F	6500	250	2350	28,000	3.3 / 500	0.075	0.048	150	600	500	7	I-9
RM600DG-130S	6500	600	4800	96,000	4.0 / 600	0.022	0.016	150	1,000	1,000	7	I-9

Dual Fast Recovery Diodes - Inverse Configuration

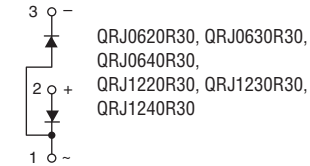

Dual High Isolation High Voltage Fast Recovery Diodes

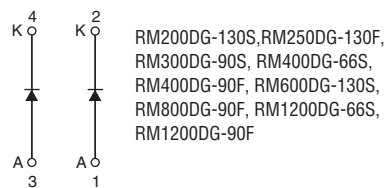

Common Anode Fast Recovery Diodes (Refer to device datasheets at www.pwr.com for test conditions.)



QRC0620R30, QRC1220R30,
QRF0620R30, QRF1220R30



QRC0630R30, QRF0630R30,
QRC0640R30, QRF0640R30,
QRC1230R30, QRF1230R30,
QRC1240R30, QRF1240R30



QRC3310001,
QRC3310002

Type	V _{RRM} Volts (V _{RSM} = V _{RRM} + 100V)	I _{dc} /T _c Amperes/°C (180° sin)	NORTH AMERICAN		V _{FM} /I _{FM} Volts/Amperes (T _j = 25°C)	t _{rr}			R _{th(j-c)} °C/W	R _{th(c-s)} °C/W	T _{j(max)} °C	Weight	Outline Drawings	
			I _{FSM} Amperes (8.3ms, T _{j(max)} , 100% V _{RRM} Reapplied)	i ² t A ² sec (8.3ms, T _{j(max)} , 100% V _{RRM} Reapplied)		t _{rr} ns	at I _f Amperes	di/dt Amperes/μs					Number	Page
QRF0620R30	600	140 / 80	TBD	TBD	2.3 / 150	120	100	TBD	0.205	0.2	150	150	1	I-7
QRF0630R30	600	210 / 80	TBD	TBD	2.2 / 150	120	150	TBD	0.137	0.2	150	180	8	I-9
QRF0640R30	600	280 / 80	TBD	TBD	2.2 / 200	120	200	TBD	0.103	0.2	150	180	8	I-9
QRF1220R30	1200	140 / 80	1700	12,000	3.2 / 100	150	100	TBD	0.15	0.2	150	150	1	I-7
QRF1230R30	1200	210 / 80	2550	27,000	3.2 / 150	150	150	TBD	0.1	0.2	150	180	8	I-9
QRF1240R40	1200	280 / 80	3400	48,000	3.2 / 200	150	200	TBD	0.075	0.02	150	180	8	I-9

Common Cathode Fast Recovery Diodes (Refer to device datasheets at www.pwr.com for test conditions.)

Type	V _{RRM} Volts (V _{RSM} = V _{RRM} + 100V)	I _{dc} /T _c Amperes/°C (180° sin)	NORTH AMERICAN		V _{FM} /I _{FM} Volts/Amperes (T _j = 25°C)	t _{rr}			R _{th(j-c)} °C/W	R _{th(c-s)} °C/W	T _{j(max)} °C	Weight	Outline Drawings	
			I _{FSM} Amperes (8.3ms, T _{j(max)} , 100% V _{RRM} Reapplied)	i ² t A ² sec (8.3ms, T _{j(max)} , 100% V _{RRM} Reapplied)		t _{rr} ns	at I _f Amperes	di/dt Amperes/μs					Number	Page
QRC0620R30	600	140 / 80	TBD	TBD	2.3 / 150	120	100	TBD	0.205	0.2	150	150	1	I-7
QRC0630R30	600	210 / 80	TBD	TBD	2.2 / 150	120	150	TBD	0.137	0.2	150	180	8	I-9
QRC0640R30	600	280 / 80	TBD	TBD	2.2 / 200	120	200	TBD	0.103	0.2	150	180	8	I-9
QRC1220R30	1200	140 / 80	1700	12,000	3.2 / 100	150	100	TBD	0.15	0.2	150	150	1	I-7
QRC1230R30	1200	210 / 80	2550	27,000	3.2 / 150	150	150	TBD	0.1	0.2	150	180	8	I-9
QRC1240R30	1200	280 / 80	3400	48,000	3.2 / 200	150	200	TBD	0.075	0.2	150	180	8	I-9
QRC3310001	3300	86 / 80	TBD	TBD	4.3 / 100	1200	100	-200	0.12	0.05	150	250	9	I-9
QRC3310002	3300	86 / 80	TBD	TBD	4.3 / 100	1200	100	-200	0.2	0.05	150	250	9	I-9

Common Anode Fast Recovery Diodes

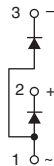

QRF0620R30, QRF0630R30,
QRF0640R30,
QRF1220R30, QRF1230R30,
QRF1240R40

Common Cathode Fast Recovery Diodes



QRC0620R30, QRC0630R30,
QRC0640R30,
QRC1220R30, QRC1230R30,
QRC1240R30
QRC3310001, QRC3310002

1 QR_0620R30, QR_1220R30

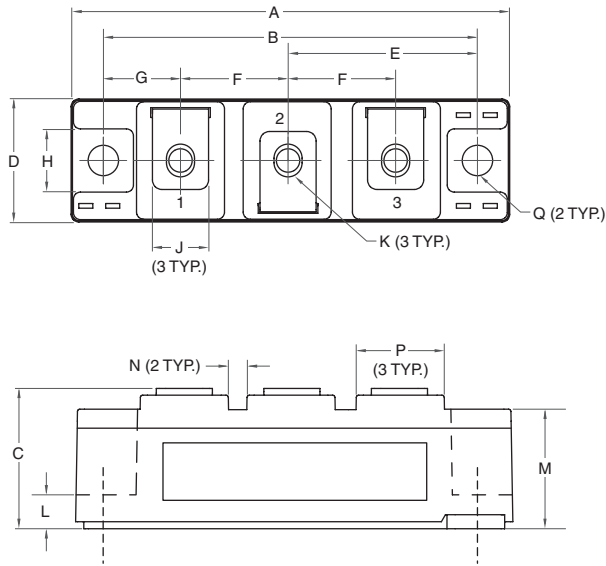

Dim.	Inches	Millimeters
A	3.68	93.5
B	3.150±0.01	80.0±0.25
C	1.18	30.0
D	1.02	26.0
E	1.59	40.5
F	0.90	23.0
G	0.65	16.5
H	0.51	13.0

Dim.	Inches	Millimeters
J	0.47	12.0
K	M5 Metric	M5
L	0.30	7.5
M	1.0	25.4
N	0.16	4.0
P	0.75	19.0
Q	0.256 Dia.	6.5 Dia.

2 RM400HA-34S

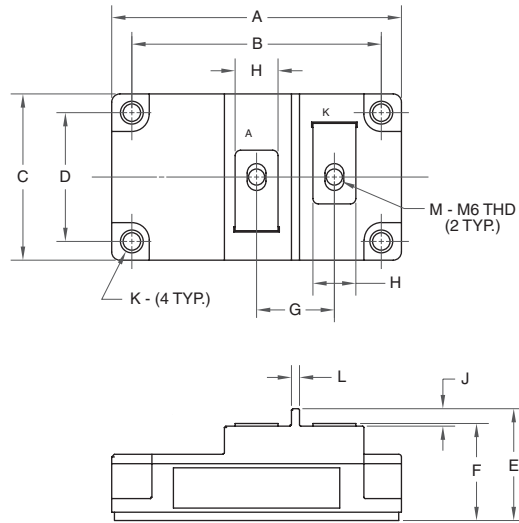

Dim.	Inches	Millimeters
A	4.25 Max.	108.0 Max.
B	3.661±0.012	93.0±0.3
C	2.44 Max.	62.0 Max.
D	1.89±0.012	48.0±0.3
E	1.63 Max.	41.5 Max.
F	1.42 Max.	36.0 Max.

Dim.	Inches	Millimeters
G	1.14	29.0
H	0.63	16.0
J	0.26	6.5
K	0.256 Dia.	6.5 Dia.
L	0.12	3.0
M	M6 Metric	M6

3 RM600HE-90S, RM1200HE-66S, RM1800HE-34S

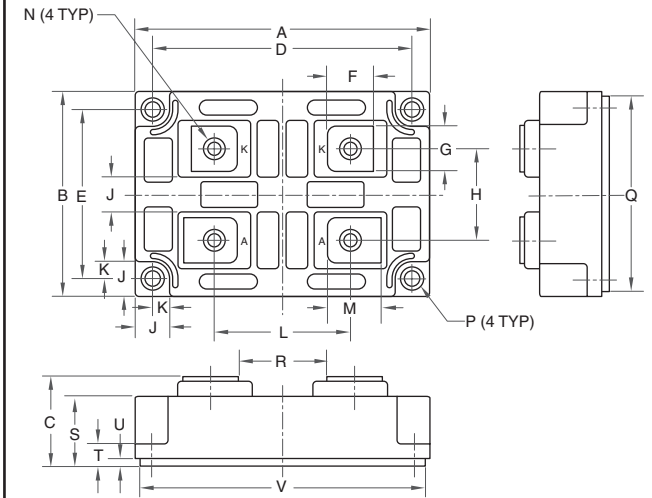

Dim.	Inches	Millimeters
A	5.12+0.04/-0.0	130.0+1.0/-0.0
B	3.54±0.04	90.0±1.0
C	1.50+0.04/-0.0	38.0+1.0/-0.0
D	4.49±0.012	114.0±0.3
E	2.91±0.012	74.0±0.3
F	0.81	20.5
G	0.79	20.0
H	1.57±0.2	40.0±0.5
J	0.59	15.0
K	0.28	7.0

Dim.	Inches	Millimeters
L	2.4±0.2	61.5±0.5
M	0.94	24.0
N	M8 Metric	M8
P	0.26 Dia.	6.5 Dia.
Q	3.37	85.5
R	1.56	39.5
S	1.17	29.7
T	0.37	9.3
U	0.12	3.0
V	4.94	125.5

4 RM900DB-90S, RM900HC-90S, RM1200DB-66S

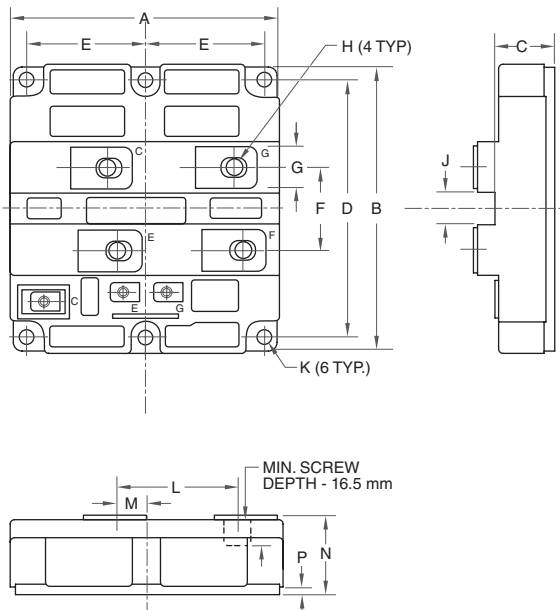

Dim.	Inches	Millimeters
A	5.12	130.0
B	5.51	140.0
C	1.16	29.5
D	4.88±0.01	124.0±0.25
E	2.24±0.01	57.0±0.25
F	1.57	40.0
G	0.79	20.0
H	M8 Metric	M8

Dim.	Inches	Millimeters
J	0.59	15.0
K	0.28 Dia.	7.0 Dia.
L	2.4	61.5
M	0.71	18.0
N	1.5+0.04/-0.0	38.0+1/0/-0.0
P	0.2	5.0

5 QRS0620T30, QRS0640T30, QRS0660T30, QRS0680T30, QRS1220T30, QRS1240T30, QRS1260T30

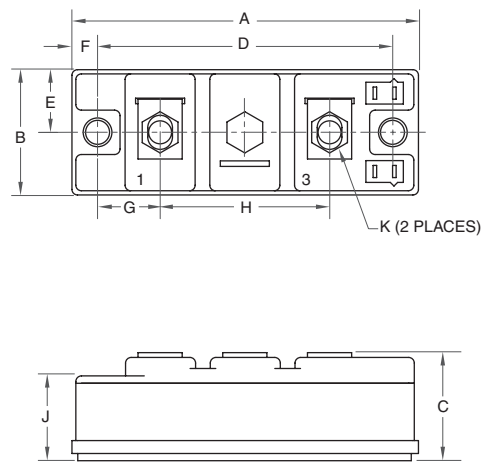

Dim.	Inches	Millimeters
A	3.70	94.0
B	1.34	34.0
C	1.18	30.0
D	3.15	80.0
E	0.67	17.0

Dim.	Inches	Millimeters
F	0.28	6.99
G	0.67	17.1
H	1.81	46.0
J	0.91	23.0
K	M6 x 1.0 Metric	M6 x 1.0

6 RM400DY-66S, RM600DY-66S

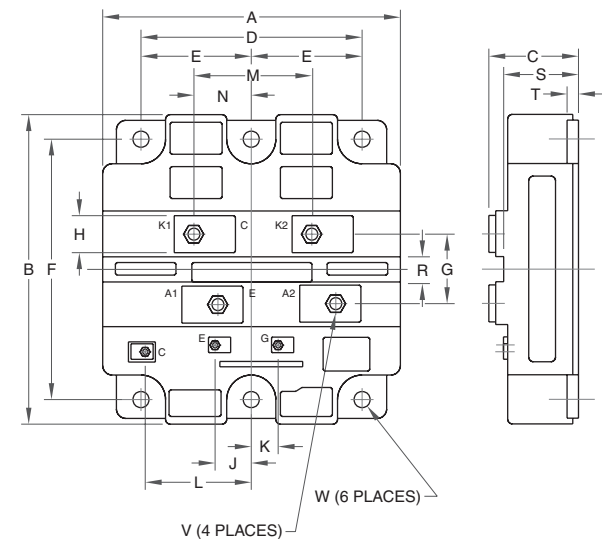

Dim.	Inches	Millimeters
A	5.12	130.0
B	5.51	140.0
C	1.50+0.8/-0.0	38.0+2.0/-0.0
D	4.49	114.0
E	2.24±0.01	57.0±0.25
F	4.88±0.01	124.0±0.25
G	1.58	40.0
H	0.79	20.0

Dim.	Inches	Millimeters
M	2.42	61.5
N	0.71	18.0
R	0.59	15.0
S	1.18	30.0
T	0.20	5.0
V	M8 Metric	M8
W	0.28 Dia.	7.0 Dia.

7

RM200DG-130S, RM250DG-130F, RM300DG-90S,
RM400DG-66S, RM400DG-90F, RM600DG-130S,
RM800DG-90F, RM1200DG-66S, RM1200DG-90F

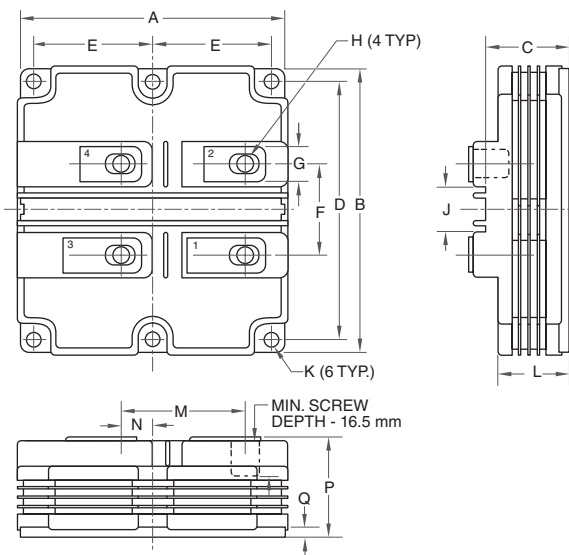

Dim.	Inches	Millimeters
A	5.12±0.2	130.0±0.5
B	5.51±0.2	140.0±0.5
C	1.59±0.2	40.4±0.5
D	4.88±0.01	124.0±0.25
E	2.24±0.01	57.0±0.25
F	1.73±0.2	44.0±0.5
G	0.67±0.004	17.0±0.1
H	M8 Metric	M8

Dim.	Inches	Millimeters
J	0.87±0.012	22.0±0.3
K	0.28 Dia.	7.0 Dia.
L	1.35±0.2	34.4±0.5
M	2.41±0.2	61.2±0.5
N	0.65±0.2	16.5±0.5
P	1.89+0.04/-0.0	48.0+1/0/-0.0
Q	0.2±0.006	5.0±0.15

8

QR_0630R30, QR_0640R30,
QR_1230R30, QR_1240R30

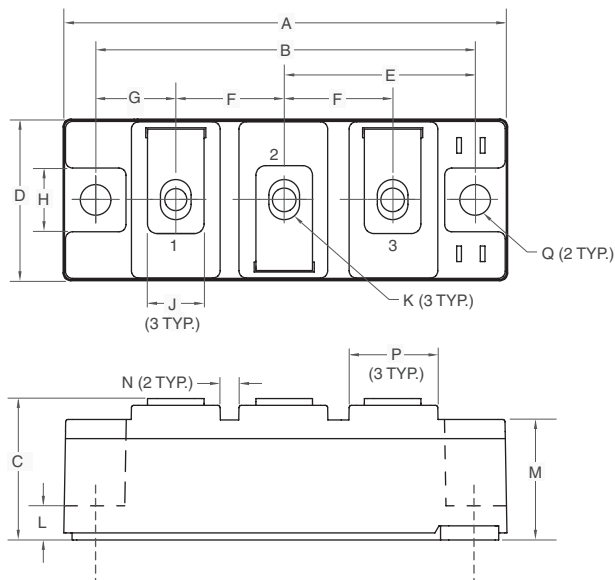

Dim.	Inches	Millimeters
A	3.70	94.0
B	3.150±0.01	80.0±0.25
C	1.18	30.0
D	1.34	34.0
E	1.57	40.0
F	0.90	23.0
G	0.67	17.0
H	0.51	13.0

Dim.	Inches	Millimeters
J	0.47	12.0
K	M6 Metric	M6
L	0.30	7.5
M	1.0	25.4
N	0.16	4.0
P	0.75	19.0
Q	0.256 Dia.	6.5 Dia.

9

QRC3310001, QRC3310002,
QRD3310001, QRD3310002,
QRD3310003, QRD3310005

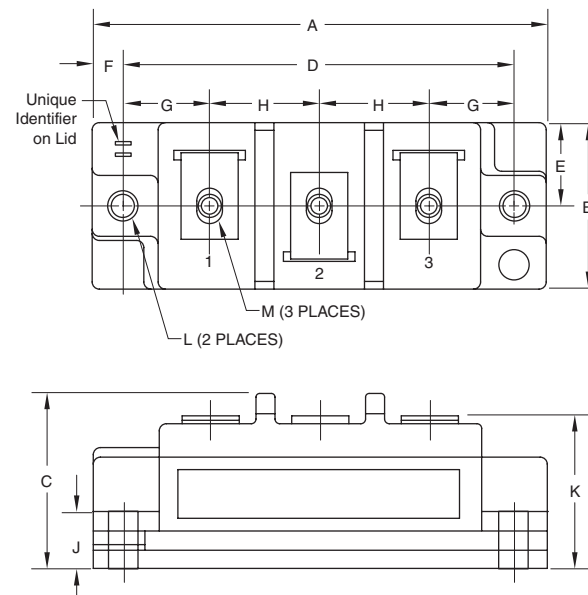

Dim.	Inches	Millimeters
A	3.70	94.0
B	1.34	34.0
C	1.40	35.6
D	3.15	80.0
E	0.67	17.0
F	0.28	6.99

Dim.	Inches	Millimeters
G	0.67	17.1
H	0.91	23.0
J	0.36	9.0
K	1.18	30.0
L	0.216	5.5
M	#10-32	#10-32

DC-DC
ConvertersGate Drivers
& IPM
InterfaceCustom
ModulesIGBT
Assemblies

Assemblies

Fast Recovery
Diode ModulesThyristor &
Diode
ModulesDiscrete
RectifiersDiscrete
Thyristors

DIPIPM

IPMs

MOSFET
ModulesHybrid
& SiC
Modules

IGBTs

10 QRS061K001

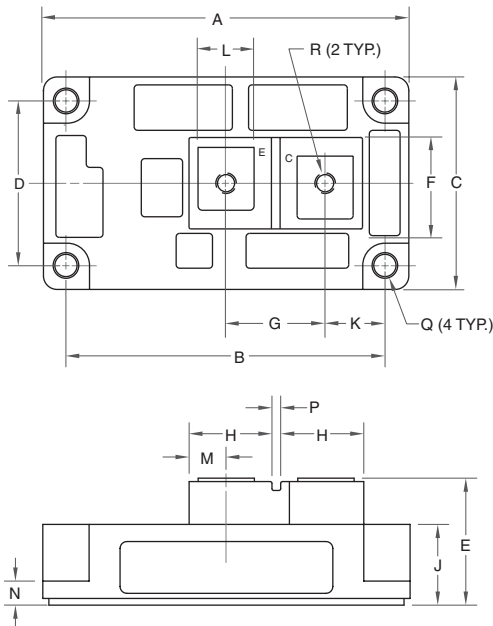

Dim.	Inches	Millimeters	Dim.	Inches	Millimeters
A	4.21	107.0	J	0.93	23.5
B	3.661±0.01	93.0±0.25	K	0.69	17.5
C	2.44	62.0	L	0.63	16.0
D	1.89±0.01	48.0±0.25	M	0.43	11.0
E	1.42 Max.	36.0 Max.	N	0.28	7.0
F	1.18	30.0	P	0.12	3.0
G	1.14	29.0	Q	0.26 Dia.	6.5 Dia.
H	0.94	24.0	R	M6 Metric	M6

11 RM1000DC-66F, RM1500DC-66F

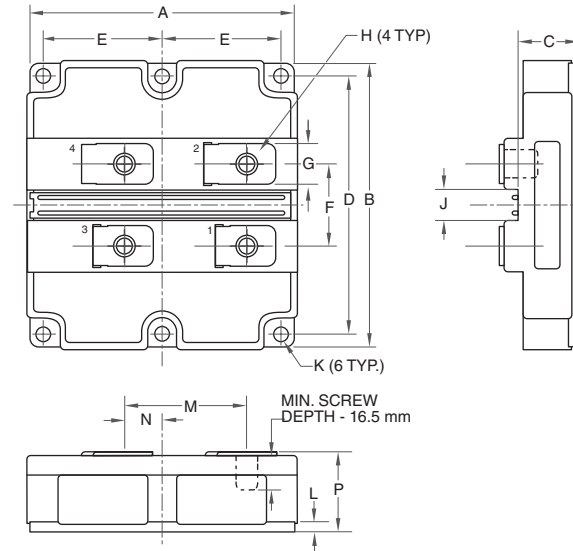

Dim.	Inches	Millimeters	Dim.	Inches	Millimeters
A	5.12±0.02	130.0±0.5	H	M8 Metric	M8
B	5.51±0.02	140.0±0.5	J	0.59±0.012	15.0±0.3
C	1.16±0.02	29.5±0.5	K	0.28 Dia.	7.0 Dia.
D	4.88±0.009	124.0±0.25	L	0.2±0.008	5.0±0.2
E	2.24±0.009	57.0±0.25	M	2.42±0.012	61.5±0.3
F	1.57±0.012	40.0±0.3	N	0.71±0.012	18.0±0.3
G	0.79+0.039/-0.008	20.0+1.0/-0.2	P	1.5+0.04/-0.0	38.0+1.0/-0.0

12 RM400DY-24S

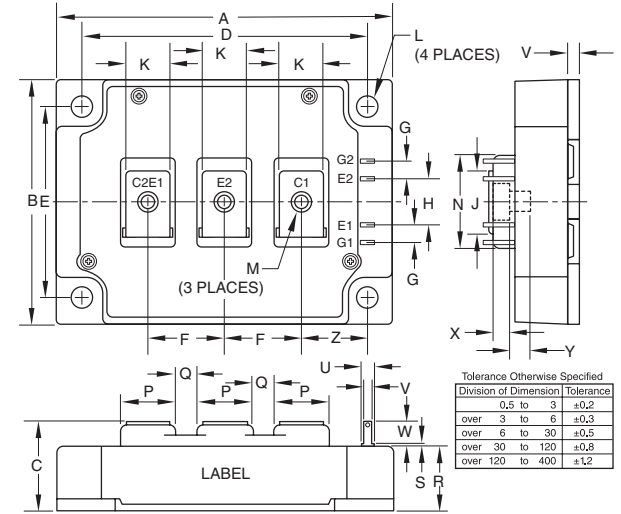

Dim.	Inches	Millimeters	Dim.	Inches	Millimeters
A	4.33	110.0	N	1.18	30.0
B	3.15	80.0	P	0.71	18.0
C	1.14+0.04/-0.02	29.0+1.0/-0.5	Q	0.28	7.0
D	3.66±0.01	93.0±0.25	R	0.83	21.2
E	2.44±0.01	62.0±0.25	S	0.33	8.5
F	0.98	25.0	T	0.0157	0.4
G	0.24	6.0	U	0.110	2.8
H	0.59	15.0	V	0.16	4.0
J	0.81	20.5	W	0.30	7.5
K	0.55	14.0	X	0.21	5.3
L	0.26 Dia.	Dia. 6.5	Y	0.47	12.0
M	M6 Metric	M6	Z	0.85	21.5

13 RM1200DB-34S

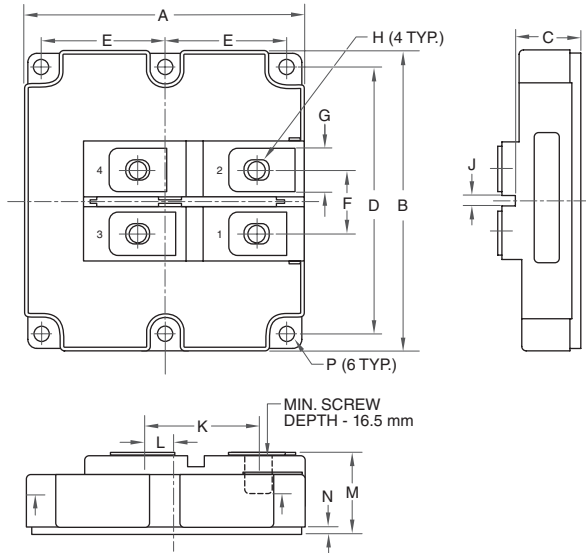

Dim.	Inches	Millimeters
A	5.12±0.02	130.0±0.5
B	5.51±0.02	140.0±0.5
C	1.16±0.02	29.5±0.5
D	4.88±0.009	124.0±0.25
E	2.24±0.009	57.0±0.25
F	1.18±0.008	30.0±0.2
G	0.79±0.004	20.0±0.1

Dim.	Inches	Millimeters
H	M8 Metric	M8
J	0.20±0.008	5.0±0.2
K	2.17±0.012	55.2±0.3
L	0.467±0.008	11.85±0.2
M	1.50+0.039/-0.0	38.0+1.0/-0.0
N	0.2±0.008	5.0±0.2
P	0.28 Dia.	7.0 Dia.

14 QRS1450001, QRS171D001

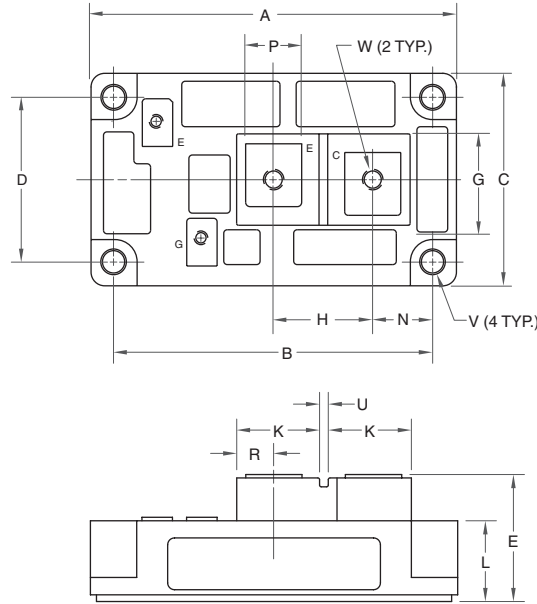

Dim.	Inches	Millimeters
A	4.21	107.0
B	3.661±0.01	93.0±0.25
C	2.44	62.0
D	1.89±0.01	48.0±0.25
E	1.42 Max.	36.0 Max.
G	1.18	30.0
H	1.14	29.0
K	0.94	24.0

Dim.	Inches	Millimeters
L	0.93	23.5
N	0.69	17.5
P	0.63	16.0
R	0.43	11.0
T	0.28	7.0
U	0.12	3.0
V	0.26 Dia.	6.6 Dia.
W	M6 Metric	M6

15 QRD3320004

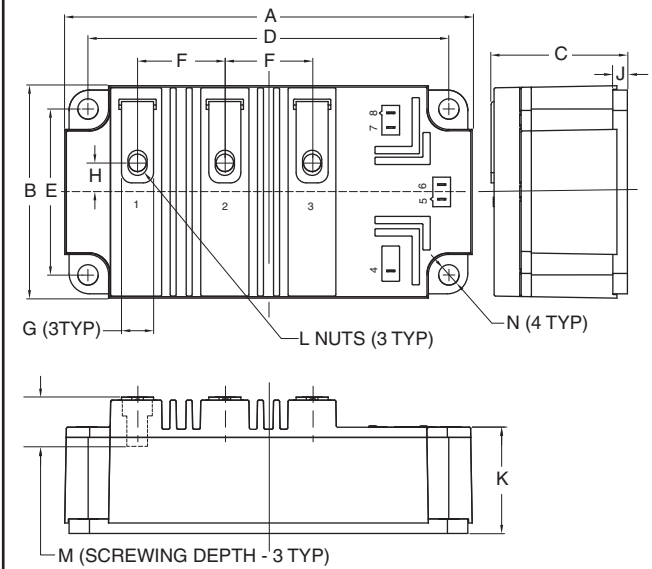

Dim.	Inches	Millimeters
A	5.51	140.0
B	2.87	73.0
C	1.50	38.0
D	4.88±0.01	124.0±0.25
E	2.24±0.01	57.0±0.25
F	1.18	30.0
G	0.43	11.0

Dim.	Inches	Millimeters
H	0.38	9.75
J	0.20	5.0
K	1.04	26.5
L	M5 Metric	M5
M	0.63 Min.	16.0 Min.
N	0.28 Dia.	7.0 Dia.

16 QRS4506001

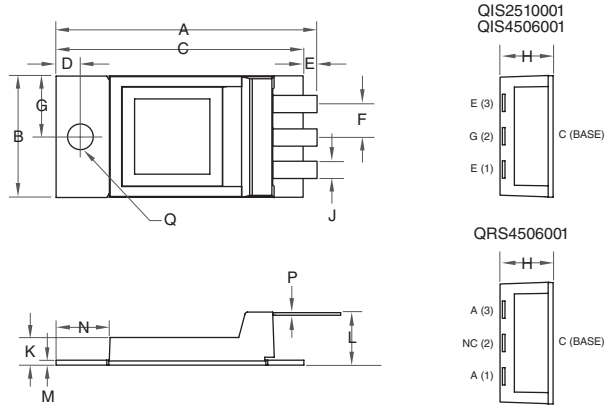

Dim.	Inches	Millimeters
A	2.31	53.6
B	0.98	25.0
C	2.01	51.0
D	0.2	5.0
E	0.1	2.5
F	0.27	6.9
G	0.49	12.5
H	0.46 Max.	11.8 Max.

Dim.	Inches	Millimeters
J	0.14	3.6
K	0.22	5.7
L	0.43	10.8
M	0.04	1.0
N	0.43	10.9
P	0.02	0.5
Q	0.21 Dia.	5.3 Dia.

17 QRS4506002, QRS6503002, QRS6505002

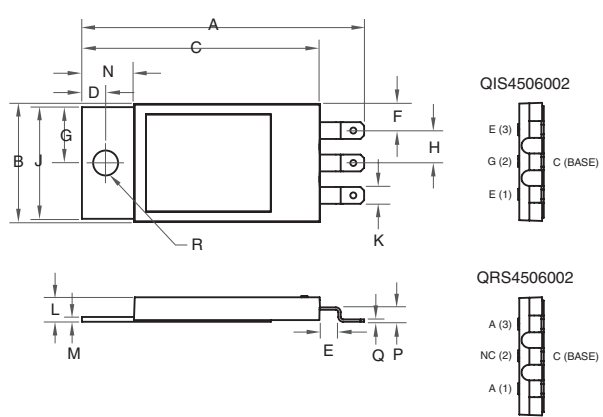

Dim.	Inches	Millimeters
A	2.35	59.7
B	0.98	25.0
C	1.98	50.3
D	0.197	5.0
E	0.22	5.5
F	0.22	5.6
G	0.465	11.8
H	0.27	6.9

Dim.	Inches	Millimeters
J	0.93	23.6
K	0.14	3.6
L	0.20	5.2
M	0.40	1.0
N	0.43	11.0
P	0.20	0.5
Q	0.12	3.0
R	0.208 Dia.	5.3 Dia.

18 RM1500HE-66F

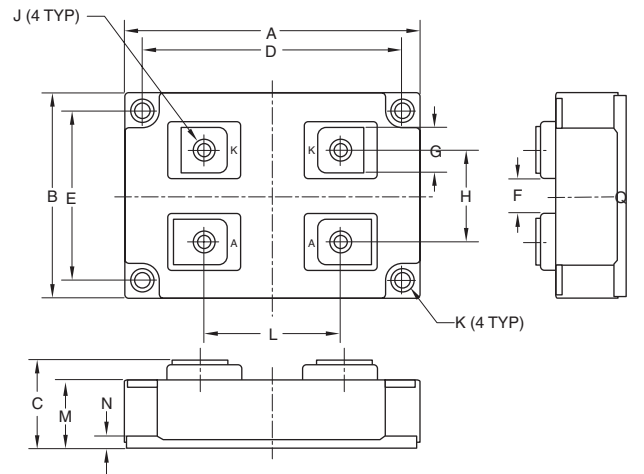

Dim.	Inches	Millimeters
A	5.12±0.02	130.0±0.5
B	3.54±0.02	90.0±0.5
C	1.50+0.04/-0.0	38.0+1.0/-0.0
D	4.49±0.01	114.0±0.25
E	2.91±0.01	74.0±0.25
F	0.59±0.012	15.0±0.3
G	0.79+0.04/-0.008	20.0+1.0/-0.2

Dim.	Inches	Millimeters
H	1.57±0.2	40.0±0.5
J	M8 Metric	M8
K	0.28 Dia.	7.0 Dia.
L	2.4±0.2	61.5±0.5
M	1.17±0.02	29.7±0.5
N	0.2±0.008	5.0±0.2

ASSEMBLIES

Air Cooled / Liquid Cooled / Integrated Power Structures

Powerex has developed a wide line-up of standard air or liquid cooled rectifier / thyristor assemblies in all common circuit configurations utilizing either discrete disc or isolated baseplate power semiconductors. A range of standard extrusions or chill blocks and clamps are used to produce a comprehensive range of assemblies from 100 to 6000A DC output in air cooled and 400 to 15000A DC output when liquid cooled.

When standard assemblies are not sufficient, the Powerex engineering team will design and manufacture power semiconductor assemblies to specific application requirements. These engineered solutions provide the optimum solution to electrical, thermal or mechanical challenges.

Applications Include:

- Battery Chargers
- Induction Heating/Melting
- Motor Controls
- Motor Starters
- Power Supplies
- Transportation
- UPS
- Welding

Circuit Configurations:

- Single
- Half-Bridge
- AC Switch
- Common Cathode/Common Anode
- Single-Phase Bridge
- Three-Phase Bridge

Options Available in Engineered Assemblies:

- Bus Bars
- Fans
- Fuses
- Gate Drive
- Insulators
- Terminal Blocks
- Thermal Sensors
- Snubbers (R-C Transient Suppressors)

TABLE OF CONTENTS

PA Assembly Overview	J-2
PD Assembly Overview	J-3
Three-Phase AC Switch	J-4
Three-Phase DC Rectifier	J-6
Three-Phase Half Controlled Rectifier	J-8
Three-Phase Full Controlled Rectifier	J-10
Outline Drawings	J-12
Medium Voltage Assemblies	J-17

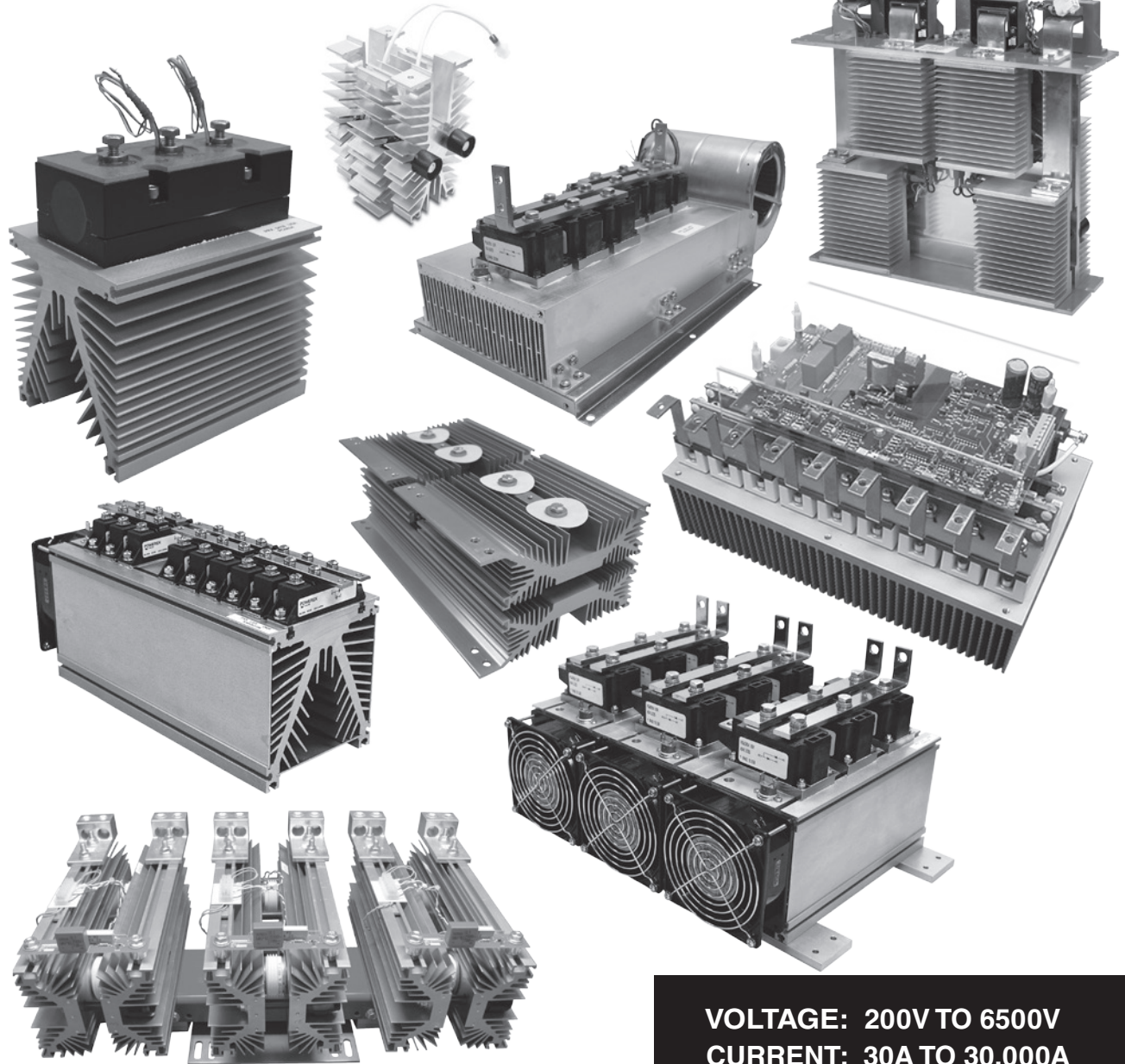

VOLTAGE: 200V TO 6500V
CURRENT: 30A TO 30,000A

PA Assembly Overview

Powerex assemblies with the PA prefix are available in two varieties. PAA assemblies are disc-based assemblies and PAB assemblies are module-based assemblies.

Fans are not included as part of the standard assembly.

If your application requirements do not allow the selection of a standard assembly, as listed on pages J-4 through J-5, then to determine the proper assembly for your application, the following information is needed:

(1) Choose the Circuit Type:

Single-Phase AC Switch

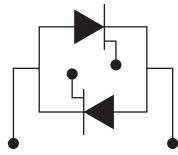

Three-Phase AC Switch

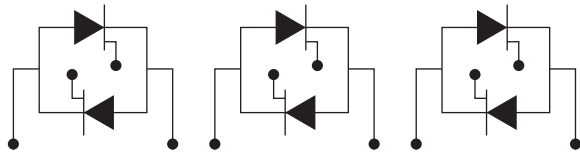

(2) Electrical Parameters:

- Maximum Continuous Output Current (Amps) _____
Maximum Overload
 - Output DC Current (Amps) _____
 - Overload Duration (Sec) _____
- Input Voltage (Volts) _____
(VAC-RMS for Single Phase, VAC-RMS line-to-line for Three-Phase)
- Line Frequency: 50 Hertz or 60 Hertz Other _____ Hz

(3) Environmental Parameters:

- Maximum Ambient Temperature (°C) _____
- Humidity (0-95% Non-Condensing): _____
- Maximum Altitude (feet above sea level): _____ ft

Please email this information to our IPP Department at ipp@pwr.com.

A Powerex engineer will review the information and contact you to discuss your assembly needs.

PA Numbering System

PAA6T6200620 is a 600 Volt disc based, Three-Phase AC Assembly.

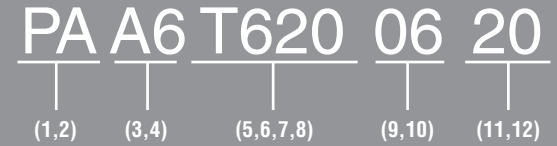

(1,2) Circuit Code:

Rectifier	SCR	Half-Control	Full-Control
-----------	-----	--------------	--------------

PA (AC Switch)

Powerex supplies the sink jumper (AC connection) on the PA air cooled assembly types only.



(3,4) Sink Code: Customer Specific

(5,6,7,8) Device Code: Application Specific

(9,10) Voltage Code:

- 02 = 200
- 04 = 400
- 06 = 600
- 08 = 800
- 10 = 1000
- 12 = 1200
- 14 = 1400
- 16 = 1600
- 18 = 1800
- 20 = 2000
- 22 = 2200
- 24 = 2400
- 26 = 2600
- 28 = 2800
- 30 = 3000

(11,12) Current Code: Device Specific

PD Assembly Overview

Powerex assemblies with the PD prefix are available in two varieties. PDA assemblies are disc-based assemblies and PDB assemblies are module-based assemblies.

Fans are not included as part of the standard assembly.

If your application requirements do not allow the selection of a standard assembly, as listed on pages J-6 through J-11, then to determine the proper assembly for your application, the following information is needed:

(1) Choose the Circuit Type:

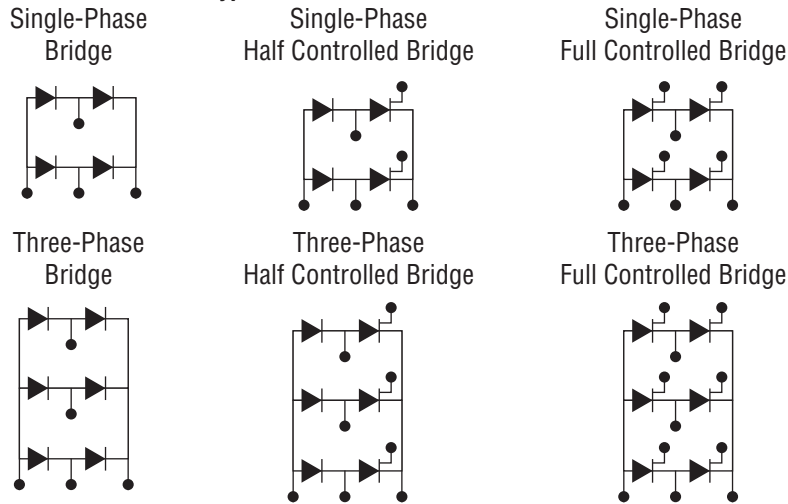

(2) Electrical Parameters:

- Maximum Continuous Output Current (Amps) _____
Maximum Overload
 - Output DC Current (Amps) _____
 - Overload Duration (Sec) _____
- Input Voltage (Volts) _____
(VAC-RMS for Single Phase, VAC-RMS line-to-line for Three-Phase)
- Line Frequency: 50 Hertz or 60 Hertz Other _____ Hz

(3) Environmental Parameters:

- Maximum Ambient Temperature (°C) _____
- Humidity (0-95% Non-Condensing): _____
- Maximum Altitude (feet above sea level): _____ ft

Please email this information to our IPP Department at ipp@pwr.com. A Powerex engineer will review the information and contact you to discuss your assembly needs.

PD Numbering System

PDA9T9R9 22 10 is a 2200 Volt, Air Cooled Doubler Assembly.



(1,2) Circuit Code:

Rectifier SCR Half-Control Full-Control

PC (Positive Centertap – Common Cathode Connection)



(3,4) Sink Code: Customer Specific

PD (Doubler Assemblies)

Remember to check the number of assemblies required for your circuit configuration.



(5,6,7,8) Device Code: Application Specific

PN (Negative Centertap – Common Anode Connection)



(9,10) Voltage Code:

- 02 = 200
- 04 = 400
- 06 = 600
- 08 = 800
- 10 = 1000
- 12 = 1200
- 14 = 1400
- 16 = 1600
- 18 = 1800
- 20 = 2000
- 22 = 2200
- 24 = 2400
- 26 = 2600
- 28 = 2800
- 30 = 3000

PP (Parallel Connection)

Connections available as Special Purpose Assemblies with selected device matching negotiated with Powerex application engineers.



PR (Single Assemblies)

Remember to check the number of assemblies required for your circuit configuration.



PS (Series Connection)

Connections available as Special Purpose Assemblies with the following options: device selection and matching; chill blocks and fittings (targets); disc clamp designs with additional spring deflection and additional voltage capabilities, corona (CIV, CEV) and Hipot testing, balancing capacitors, resistors.



(11,12) Current Code: Device Specific

PT (Single Assemblies)

Remember to check the number of assemblies required for your circuit configuration.



Three-Phase AC Switch

Discs, Hockey Puks

Part Number	Voltage	Output Current A _{RMS} Amperes	Package Size (inches)	Quantity Required for 3-Phase Circuit	Ambient Temperature (°C)	Inlet Air Velocity (LFM)	Approximate Weight		Outline Drawings	
							(lbs)	(kgs)	Number	Page
PAA6T6200620*	600	400	13.125 x 5.75 x 5.75	3	50	1000	12.8	5.8	1	J-12
PAA6T6201220*	1200	400	13.125 x 5.75 x 5.75	3	50	1000	12.8	5.8	1	J-12
PAA6T6201620*	1600	400	13.125 x 5.75 x 5.75	3	50	1000	12.8	5.8	1	J-12
PAA7T7200645*	600	600	13.125 x 5.625 x 6.25	3	50	1000	13.7	6.2	2	J-12
PAA7T7201245*	1200	600	13.125 x 5.625 x 6.25	3	50	1000	13.7	6.2	2	J-12
PAA7T7201645*	1600	600	13.125 x 5.625 x 6.25	3	50	1000	13.7	6.2	2	J-12
PAA7T7200655*	600	700	13.125 x 5.625 x 6.25	3	50	1000	13.7	6.2	2	J-12
PAA7T7201255*	1200	700	13.125 x 5.625 x 6.25	3	50	1000	13.7	6.2	2	J-12
PAA7T7201655*	1600	700	13.125 x 5.625 x 6.25	3	50	1000	13.7	6.2	2	J-12
PAA7T7S00675*	600	800	13.125 x 5.625 x 5.80	3	50	1000	12.8	5.8	3	J-13
PAA7T7S01275*	1200	800	13.125 x 5.625 x 5.80	3	50	1000	12.8	5.8	3	J-13
PAA7T7S01675*	1600	800	13.125 x 5.625 x 5.80	3	50	1000	12.8	5.8	3	J-13
PAA9T9G00610*	600	1350	17.125 x 9.938 x 6.44	3	50	1000	45.0	20.4	4	J-13
PAA9T9G01210*	1200	1350	17.125 x 9.938 x 6.44	3	50	1000	45.0	20.4	4	J-13
PAA9T9G01610*	1600	1350	17.125 x 9.938 x 6.44	3	50	1000	45.0	20.4	4	J-13
PAA9T9G00612*	600	1700	17.125 x 9.938 x 6.44	3	50	1000	45.0	20.4	4	J-13
PAA9T9G01212*	1200	1700	17.125 x 9.938 x 6.44	3	50	1000	45.0	20.4	4	J-13
PAA9T9G01612*	1600	1700	17.125 x 9.938 x 6.44	3	50	1000	45.0	20.4	4	J-13
PAAATA200616*	600	2100	21.12 x 12.69 x 7.84	3	50	1000	86.4	39.2	5	J-14
PAAATA201216*	1200	2100	21.12 x 12.69 x 7.84	3	50	1000	86.4	39.2	5	J-14
PAAATA201616*	1600	2100	21.12 x 12.69 x 7.84	3	50	1000	86.4	39.2	5	J-14
PAAATA200618*	600	2500	21.12 x 12.69 x 7.84	3	50	1000	86.4	39.2	5	J-14
PAAATA201218*	1200	2500	21.12 x 12.69 x 7.84	3	50	1000	86.4	39.2	5	J-14
PAAATA201618*	1600	2500	21.12 x 12.69 x 7.84	3	50	1000	86.4	39.2	5	J-14

*Part number represents a single-phase assembly, you will need three assemblies to complete a three-phase circuit.

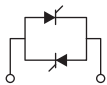

Single-Phase Assembly –
(3 Required for Three-Phase Circuit)

Three-Phase AC Switch

Isolated Modules

Part Number	Voltage	Output Current A _{rms} Amperes	Package Size (inches)	Quantity Required for 3-Phase Circuit	Ambient Temperature (°C)	Inlet Air Velocity (LFM)	Approximate Weight		Outline Drawings	
							(lbs)	(kgs)	Number	Page
PAB1CD430890	800	100	6.00 x 4.92 x 7.00	1	50	800	6.8	3.1	6	J-14
PAB1CD431290	1200	100	6.00 x 4.92 x 7.00	1	50	800	6.8	3.1	6	J-14
PAB1CD431690	1600	100	6.00 x 4.92 x 7.00	1	50	800	6.8	3.1	6	J-14
PAB2CD630815	800	150	9.00 x 4.92 x 7.00	1	50	800	11.0	5.0	8	J-15
PAB2CD631215	1200	150	9.00 x 4.92 x 7.00	1	50	800	11.0	5.0	8	J-15
PAB2CD631615	1600	150	9.00 x 4.92 x 7.00	1	50	800	11.0	5.0	8	J-15
PAB3ND430825	800	200	12.00 x 4.92 x 8.00	1	50	800	18.75	8.5	10	J-16
PAB3ND431225	1200	200	12.00 x 4.92 x 8.00	1	50	800	18.75	8.5	10	J-16
PAB3ND431625	1600	200	12.00 x 4.92 x 8.00	1	50	800	18.75	8.5	10	J-16
PAB2LD430850*	800	300	9.00 x 4.92 x 8.00	3	50	800	12.5	5.6	12	J-16
PAB2LD431250*	1200	300	9.00 x 4.92 x 8.00	3	50	800	12.5	5.6	12	J-16
PAB2LD431650*	1600	300	9.00 x 4.92 x 8.00	3	50	800	12.5	5.6	12	J-16

*Part number represents a single-phase assembly, you will need three assemblies to complete a three-phase circuit.

PAB1CD430890, PAB1CD431290, PAB1CD431690,
PAB2CD630815, PAB2CD631215, PAB2CD631615,
PAB3ND430825, PAB3ND431225, PAB3ND431625

PAB2LD430850, PAB2LD431250, PAB2LD431650

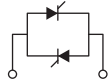
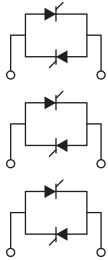

Single-Phase Assembly –
(3 Required for Three-Phase Circuit)

Three-Phase DC Rectifier Discs, Hockey Pucks

Part Number	Voltage	Output Current Apc Amperes	Package Size (inches)	Quantity Required for 3-Phase Circuit	Ambient Temperature (°C)	Inlet Air Velocity (LFM)	Approximate Weight		Outline Drawings	
							(lbs)	(kgs)	Number	Page
PDA6R6200630*	600	850	13.125 x 5.75 x 5.75	3	50	1000	12.8	5.8	1	J-12
PDA6R6201230*	1200	850	13.125 x 5.75 x 5.75	3	50	1000	12.8	5.8	1	J-12
PDA6R6201630*	1600	850	13.125 x 5.75 x 5.75	3	50	1000	12.8	5.8	1	J-12
PDA7R7S00608*	600	1200	13.125 x 5.625 x 5.80	3	50	1000	12.8	5.8	3	J-13
PDA7R7S01208*	1200	1200	13.125 x 5.625 x 5.80	3	50	1000	12.8	5.8	3	J-13
PDA7R7S01608*	1600	1200	13.125 x 5.625 x 5.80	3	50	1000	12.8	5.8	3	J-13
PDA7R7S00612*	600	1650	13.125 x 5.625 x 5.80	3	50	1000	12.8	5.8	3	J-13
PDA7R7S01212*	1200	1650	13.125 x 5.625 x 5.80	3	50	1000	12.8	5.8	3	J-13
PDA7R7S01612*	1600	1650	13.125 x 5.625 x 5.80	3	50	1000	12.8	5.8	3	J-13
PDA7R7S00616*	600	2450	13.125 x 5.625 x 5.80	3	50	1000	12.8	5.8	3	J-13
PDA7R7S01216*	1200	2450	13.125 x 5.625 x 5.80	3	50	1000	12.8	5.8	3	J-13
PDA7R7S01616*	1600	2450	13.125 x 5.625 x 5.80	3	50	1000	12.8	5.8	3	J-13
PDA9R9G00612*	600	2700	17.125 x 9.938 x 6.44	3	50	1000	45.0	20.4	4	J-13
PDA9R9G01212*	1200	2700	17.125 x 9.938 x 6.44	3	50	1000	45.0	20.4	4	J-13
PDA9R9G01612*	1600	2700	17.125 x 9.938 x 6.44	3	50	1000	45.0	20.4	4	J-13
PDA9R9G00618*	600	3300	17.125 x 9.938 x 6.44	3	50	1000	45.0	20.4	4	J-13
PDA9R9G01218*	1200	3300	17.125 x 9.938 x 6.44	3	50	1000	45.0	20.4	4	J-13
PDA9R9G01618*	1600	3300	17.125 x 9.938 x 6.44	3	50	1000	45.0	20.4	4	J-13
PDA9R9G00622*	600	4500	17.125 x 9.938 x 6.44	3	50	1000	45.0	20.4	4	J-13
PDA9R9G01222*	1200	4500	17.125 x 9.938 x 6.44	3	50	1000	45.0	20.4	4	J-13
PDA9R9G01622*	1600	4500	17.125 x 9.938 x 6.44	3	50	1000	45.0	20.4	4	J-13
PDAARA200636*	600	5800	21.12 x 12.69 x 7.84	3	50	1000	86.4	39.2	5	J-14
PDAARA201236*	1200	5800	21.12 x 12.69 x 7.84	3	50	1000	86.4	39.2	5	J-14
PDAARA201636*	1600	5800	21.12 x 12.69 x 7.84	3	50	1000	86.4	39.2	5	J-14

*Part number represents a single-phase assembly, you will need three assemblies to complete a three-phase circuit.

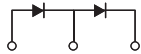

Single-Phase Assembly –
(3 Required for Three-Phase Circuit)

Three-Phase DC Rectifier Isolated Modules

Part Number	Voltage	Output Current A _{DC} Amperes	Package Size (inches)	Quantity Required for 3-Phase Circuit	Ambient Temperature (°C)	Inlet Air Velocity (LFM)	Approximate Weight		Outline Drawings	
							(lbs)	(kgs)	Number	Page
PDB1CD410899	800	150	6.00 x 4.92 x 7.00	1	50	800	6.8	3.1	7	J-15
PDB1CD411299	1200	150	6.00 x 4.92 x 7.00	1	50	800	6.8	3.1	7	J-15
PDB1CD411699	1600	150	6.00 x 4.92 x 7.00	1	50	800	6.8	3.1	7	J-15
PDB2CD610816	800	200	9.00 x 4.92 x 7.00	1	50	800	11.0	5.0	9	J-15
PDB2CD611216	1200	200	9.00 x 4.92 x 7.00	1	50	800	11.0	5.0	9	J-15
PDB2CD611616	1600	200	9.00 x 4.92 x 7.00	1	50	800	11.0	5.0	9	J-15
PDB3ND410826	800	300	15.00 x 4.92 x 8.00	1	50	800	18.75	8.5	11	J-16
PDB3ND411226	1200	300	15.00 x 4.92 x 8.00	1	50	800	18.75	8.5	11	J-16
PDB3ND411626	1600	300	15.00 x 4.92 x 8.00	1	50	800	18.75	8.5	11	J-16
PDB2LD410860*	800	450	9.00 x 4.92 x 8.00	3	50	800	12.5	5.6	12	J-16
PDB2LD411260*	1200	450	9.00 x 4.92 x 8.00	3	50	800	12.5	5.6	12	J-16
PDB2LD411660*	1600	450	9.00 x 4.92 x 8.00	3	50	800	12.5	5.6	12	J-16

*Part number represents a single-phase assembly, you will need three assemblies to complete a three-phase circuit.

PDB1CD410899, PDB1CD411299, PDB1CD411699,
PDB2CD610816, PDB2CD611216, PDB2CD611616,
PDB3ND410826, PDB3ND411226, PDB3ND411626

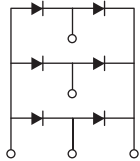

PDB2LD410860, PDB2LD411260, PDB2LD411660



Three-Phase Half Controlled Rectifier Discs, Hockey Puks

Part Number	Voltage	Output Current Apc Amperes	Package Size (inches)	Quantity Required for 3-Phase Circuit	Ambient Temperature (°C)	Inlet Air Velocity (LFM)	Approximate Weight		Outline Drawings	
							(lbs)	(kgs)	Number	Page
PDA6T6R60620*	600	500	13.125 x 5.75 x 5.75	3	50	1000	12.8	5.8	1	J-12
PDA6T6R61220*	1200	500	13.125 x 5.75 x 5.75	3	50	1000	12.8	5.8	1	J-12
PDA6T6R61620*	1600	500	13.125 x 5.75 x 5.75	3	50	1000	12.8	5.8	1	J-12
PDA6T6R60630*	600	600	13.125 x 5.75 x 5.75	3	50	1000	12.8	5.8	1	J-12
PDA6T6R61230*	1200	600	13.125 x 5.75 x 5.75	3	50	1000	12.8	5.8	1	J-12
PDA6T6R61630*	1600	600	13.125 x 5.75 x 5.75	3	50	1000	12.8	5.8	1	J-12
PDA7T7R70645*	600	800	13.125 x 5.625 x 6.25	3	50	1000	13.7	6.2	2	J-12
PDA7T7R71245*	1200	800	13.125 x 5.625 x 6.25	3	50	1000	13.7	6.2	2	J-12
PDA7T7R71645*	1600	800	13.125 x 5.625 x 6.25	3	50	1000	13.7	6.2	2	J-12
PDA7TSRS0665*	600	950	13.125 x 5.625 x 5.80	3	50	1000	12.8	5.8	3	J-13
PDA7TSRS1265*	1200	950	13.125 x 5.625 x 5.80	3	50	1000	12.8	5.8	3	J-13
PDA7TSRS1665*	1600	950	13.125 x 5.625 x 5.80	3	50	1000	12.8	5.8	3	J-13
PDA7TSRS0675*	600	1000	13.125 x 5.625 x 5.80	3	50	1000	12.8	5.8	3	J-13
PDA7TSRS1275*	1200	1000	13.125 x 5.625 x 5.80	3	50	1000	12.8	5.8	3	J-13
PDA7TSRS1675*	1600	1000	13.125 x 5.625 x 5.80	3	50	1000	12.8	5.8	3	J-13
PDA9T9R90610*	600	1750	17.125 x 9.938 x 6.44	3	50	1000	45.0	20.4	4	J-13
PDA9T9R91210*	1200	1750	17.125 x 9.938 x 6.44	3	50	1000	45.0	20.4	4	J-13
PDA9T9R91610*	1600	1750	17.125 x 9.938 x 6.44	3	50	1000	45.0	20.4	4	J-13
PDA9T9R90612*	600	2200	17.125 x 9.938 x 6.44	3	50	1000	45.0	20.4	4	J-13
PDA9T9R91212*	1200	2200	17.125 x 9.938 x 6.44	3	50	1000	45.0	20.4	4	J-13
PDA9T9R91612*	1600	2200	17.125 x 9.938 x 6.44	3	50	1000	45.0	20.4	4	J-13
PDAATARA0618*	600	3300	21.12 x 12.69 x 7.84	3	50	1000	86.4	39.2	5	J-14
PDAATARA1218*	1200	3300	21.12 x 12.69 x 7.84	3	50	1000	86.4	39.2	5	J-14
PDAATARA1618*	1600	3300	21.12 x 12.69 x 7.84	3	50	1000	86.4	39.2	5	J-14

*Part number represents a single-phase assembly, you will need three assemblies to complete a three-phase circuit.

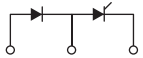

Single-Phase Assembly –
(3 Required for Three-Phase Circuit)

Three-Phase Half Controlled Rectifier Isolated Modules

Part Number	Voltage	Output Current A _{DC} Amperes	Package Size (inches)	Quantity Required for 3-Phase Circuit	Ambient Temperature (°C)	Inlet Air Velocity (LFM)	Approximate Weight		Outline Drawings	
							(lbs)	(kgs)	Number	Page
PDB1CD420890	800	150	6.00 x 4.92 x 7.00	1	50	800	6.8	3.1	7	J-15
PDB1CD421290	1200	150	6.00 x 4.92 x 7.00	1	50	800	6.8	3.1	7	J-15
PDB1CD421690	1600	150	6.00 x 4.92 x 7.00	1	50	800	6.8	3.1	7	J-15
PDB2CD620815	800	200	9.00 x 4.92 x 7.00	1	50	800	11.0	5.0	9	J-15
PDB2CD621215	1200	200	9.00 x 4.92 x 7.00	1	50	800	11.0	5.0	9	J-15
PDB2CD621615	1600	200	9.00 x 4.92 x 7.00	1	50	800	11.0	5.0	9	J-15
PDB3ND420825	800	300	15.00 x 4.92 x 8.00	1	50	800	18.75	8.5	11	J-16
PDB3ND421225	1200	300	15.00 x 4.92 x 8.00	1	50	800	18.75	8.5	11	J-16
PDB3ND421625	1600	300	15.00 x 4.92 x 8.00	1	50	800	18.75	8.5	11	J-16
PDB2LD420850*	800	450	9.00 x 4.92 x 8.00	3	50	800	12.5	5.6	12	J-16
PDB2LD421250*	1200	450	9.00 x 4.92 x 8.00	3	50	800	12.5	5.6	12	J-16
PDB2LD421650*	1600	450	9.00 x 4.92 x 8.00	3	50	800	12.5	5.6	12	J-16

*Part number represents a single-phase assembly, you will need three assemblies to complete a three-phase circuit.

PDB1CD420890, PDB1CD421290, PDB1CD421690,
PDB2CD620815, PDB2CD621215, PDB2CD621615,
PDB3ND420825, PDB3ND421225, PDB3ND421625

PDB2LD420850, PDB2LD421250, PDB2LD421650

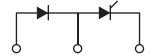
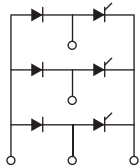

Single-Phase Assembly –
(3 Required for Three-Phase Circuit)

Three-Phase Full Controlled Rectifier Discs, Hockey Puks

Part Number	Voltage	Output Current Apc Amperes	Package Size (inches)	Quantity Required for 3-Phase Circuit	Ambient Temperature (°C)	Inlet Air Velocity (LFM)	Approximate Weight		Outline Drawings	
							(lbs)	(kgs)	Number	Page
PDA6T6200620*	600	500	13.125 x 5.75 x 5.75	3	50	1000	12.8	5.8	1	J-12
PDA6T6201220*	1200	500	13.125 x 5.75 x 5.75	3	50	1000	12.8	5.8	1	J-12
PDA6T6201620*	1600	500	13.125 x 5.75 x 5.75	3	50	1000	12.8	5.8	1	J-12
PDA6T6200630*	600	600	13.125 x 5.75 x 5.75	3	50	1000	12.8	5.8	1	J-12
PDA6T6201230*	1200	600	13.125 x 5.75 x 5.75	3	50	1000	12.8	5.8	1	J-12
PDA6T6201630*	1600	600	13.125 x 5.75 x 5.75	3	50	1000	12.8	5.8	1	J-12
PDA7T7200645*	600	800	13.125 x 5.625 x 6.25	3	50	1000	13.7	6.2	2	J-12
PDA7T7201245*	1200	800	13.125 x 5.625 x 6.25	3	50	1000	13.7	6.2	2	J-12
PDA7T7201645*	1600	800	13.125 x 5.625 x 6.25	3	50	1000	13.7	6.2	2	J-12
PDA7T7S00665*	600	950	13.125 x 5.625 x 5.80	3	50	1000	12.8	5.8	3	J-13
PDA7T7S01265*	1200	950	13.125 x 5.625 x 5.80	3	50	1000	12.8	5.8	3	J-13
PDA7T7S01665*	1600	950	13.125 x 5.625 x 5.80	3	50	1000	12.8	5.8	3	J-13
PDA7T7S00675*	600	1000	13.125 x 5.625 x 5.80	3	50	1000	12.8	5.8	3	J-13
PDA7T7S01275*	1200	1000	13.125 x 5.625 x 5.80	3	50	1000	12.8	5.8	3	J-13
PDA7T7S01675*	1600	1000	13.125 x 5.625 x 5.80	3	50	1000	12.8	5.8	3	J-13
PDA9T9G00610*	600	1750	17.125 x 9.938 x 6.44	3	50	1000	45.0	20.4	4	J-13
PDA9T9G01210*	1200	1750	17.125 x 9.938 x 6.44	3	50	1000	45.0	20.4	4	J-13
PDA9T9G01610*	1600	1750	17.125 x 9.938 x 6.44	3	50	1000	45.0	20.4	4	J-13
PDA9T9G00612*	600	2200	17.125 x 9.938 x 6.44	3	50	1000	45.0	20.4	4	J-13
PDA9T9G01212*	1200	2200	17.125 x 9.938 x 6.44	3	50	1000	45.0	20.4	4	J-13
PDA9T9G01612*	1600	2200	17.125 x 9.938 x 6.44	3	50	1000	45.0	20.4	4	J-13
PDAATA200618*	600	3300	21.12 x 12.69 x 7.84	3	50	1000	86.4	39.2	5	J-14
PDAATA201218*	1200	3300	21.12 x 12.69 x 7.84	3	50	1000	86.4	39.2	5	J-14
PDAATA201618*	1600	3300	21.12 x 12.69 x 7.84	3	50	1000	86.4	39.2	5	J-14

*Part number represents a single-phase assembly, you will need three assemblies to complete a three-phase circuit.

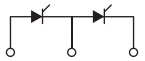

Single-Phase Assembly –
(3 Required for Three-Phase Circuit)

Three-Phase Full Controlled Rectifier Isolated Modules

Part Number	Voltage	Output Current A _{DC} Amperes	Package Size (inches)	Quantity Required for 3-Phase Circuit	Ambient Temperature (°C)	Inlet Air Velocity (LFM)	Approximate Weight		Outline Drawings	
							(lbs)	(kgs)	Number	Page
PDB1CD430890	800	150	6.00 x 4.92 x 7.00	1	50	800	6.8	3.1	7	J-15
PDB1CD431290	1200	150	6.00 x 4.92 x 7.00	1	50	800	6.8	3.1	7	J-15
PDB1CD431690	1600	150	6.00 x 4.92 x 7.00	1	50	800	6.8	3.1	7	J-15
PDB2CD630815	800	200	9.00 x 4.92 x 7.00	1	50	800	11.0	5.0	9	J-15
PDB2CD631215	1200	200	9.00 x 4.92 x 7.00	1	50	800	11.0	5.0	9	J-15
PDB2CD631615	1600	200	9.00 x 4.92 x 7.00	1	50	800	11.0	5.0	9	J-15
PDB3ND430625	600	300	15.00 x 4.92 x 8.00	1	50	800	18.75	8.5	11	J-16
PDB3ND431225	1200	300	15.00 x 4.92 x 8.00	1	50	800	18.75	8.5	11	J-16
PDB3ND431625	1600	300	15.00 x 4.92 x 8.00	1	50	800	18.75	8.5	11	J-16
PDB2LD430850*	800	450	9.00 x 4.92 x 8.00	3	50	800	12.5	5.6	12	J-16
PDB2LD431250*	1200	450	9.00 x 4.92 x 8.00	3	50	800	12.5	5.6	12	J-16
PDB2LD431650*	1600	450	9.00 x 4.92 x 8.00	3	50	800	12.5	5.6	12	J-16

*Part number represents a single-phase assembly, you will need three assemblies to complete a three-phase circuit.

PDB1CD430890, PDB1CD431290, PDB1CD431690,
PDB2CD630815, PDB2CD631215, PDB2CD631615,
PDB3ND430625, PDB3ND431225, PDB3ND431625

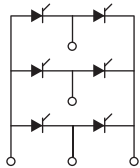

PDB2LD430850, PDB2LD431250, PDB2LD431650

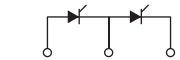

Single-Phase Assembly –
(3 Required for Three-Phase Circuit)

1 PAA6T6200620, PAA6T6201220, PAA6T6201620, PDA6R6200630, PDA6R6201230, PDA6R6201630, PDA6T6200620, PDA6T6200630, PDA6T6201220, PDA6T6201230, PDA6T6201620, PDA6T6201630, PDA6T6R60620, PDA6T6R60630, PDA6T6R61220, PDA6T6R61230, PDA6T6R61620, PDA6T6R61630

2 PAA7T7200645, PAA7T7200655, PAA7T7201245, PAA7T7201255, PAA7T7201645, PAA7T7201655, PDA7T7200645, PDA7T7201245, PDA7T7201645, PDA7T7R70645, PDA7T7R71245, PDA7T7R71645

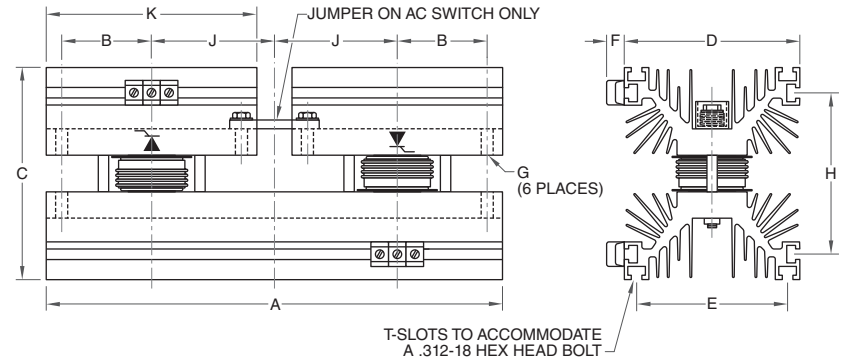
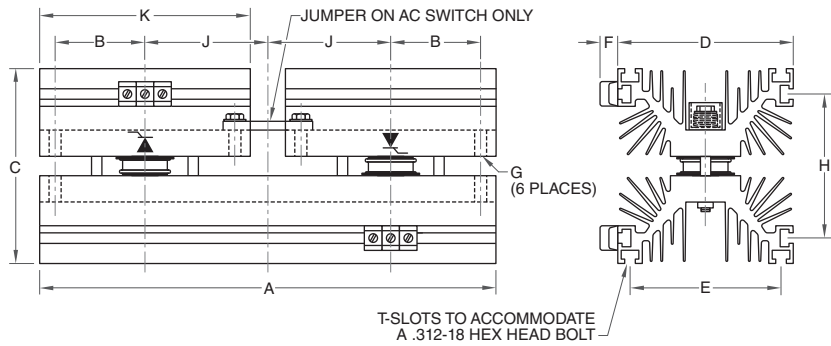

Dim.	Inches	Millimeters
A	13.06 Max.	331.72 Max.
B	2.56	65.0
C	5.60 Max.	142.24 Max.
D	5.06 Max.	128.52 Max.
E	4.25 Ref.	107.9 Ref.
F	0.5 Ref.	12.7 Ref.
G	0.344 Dia.	8.75 Dia.
H	4.10 Ref.	104.14 Ref.
J	3.5 Ref.	88.9 Ref.
K	6.0 Ref.	152.4 Ref.

Dim.	Inches	Millimeters
A	13.06 Max.	331.72 Max.
B	2.56	65.0
C	6.06 Max.	153.92 Max.
D	5.06 Max.	128.52 Max.
E	4.25 Ref.	107.9 Ref.
F	0.5 Ref.	12.7 Ref.
G	0.344 Dia.	8.75 Dia.
H	4.59 Ref.	116.58 Ref.
J	3.5 Ref.	88.9 Ref.
K	6.0 Ref.	152.4 Ref.

3

PAA7T7S00675, PAA7T7S01275, PAA7T7S01675, PDA7R7S00608, PDA7R7S00612, PDA7R7S00616, PDA7R7S01208, PDA7R7S01212, PDA7R7S01216, PDA7R7S01608, PDA7R7S01612, PDA7R7S01616, PDA7TSRS0665, PDA7TSRS0675, PDA7TSRS1265, PDA7TSRS1275, PDA7TSRS1665, PDA7TSRS1675, PDA7T7S00665, PDA7T7S00675, PDA7T7S01265, PDA7T7S01275, PDA7T7S01665, PDA7T7S01675

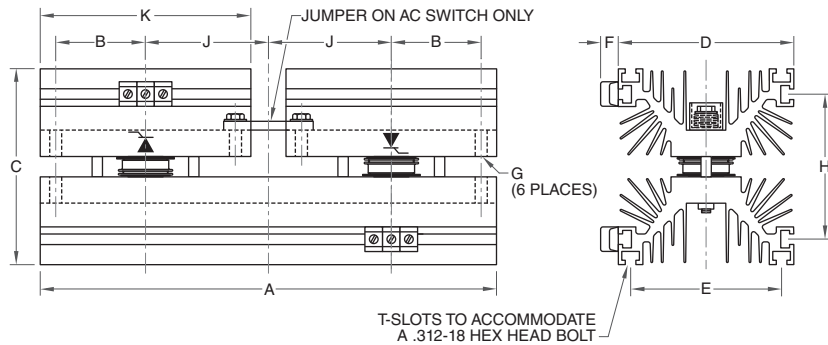

Dim.	Inches	Millimeters
A	13.06 Max.	331.72 Max.
B	2.56	65.0
C	5.64 Max.	143.26 Max.
D	5.06 Max.	128.52 Max.
E	4.25 Ref.	107.9 Ref.
F	0.5 Ref.	12.7 Ref.
G	0.344 Dia.	8.75 Dia.
H	4.13 Ref.	104.9 Ref.
J	3.5 Ref.	88.9 Ref.
K	6.0 Ref.	152.4 Ref.

4

PAA9T9G00610, PAA9T9G00612, PAA9T9G01210, PAA9T9G01212, PAA9T9G01610, PAA9T9G01612, PDA9R9G00612, PDA9R9G00618, PDA9R9G00622, PDA9R9G01212, PDA9R9G01218, PDA9R9G01222, PDA9R9G01612, PDA9R9G01618, PDA9R9G01622, PDA9T9G00610, PDA9T9G00612, PDA9T9G01210, PDA9T9G01212, PDA9T9G01610, PDA9T9G01612, PDA9T9R90610, PDA9T9R90612, PDA9T9R91210, PDA9T9R91212, PDA9T9R91610, PDA9T9R91612

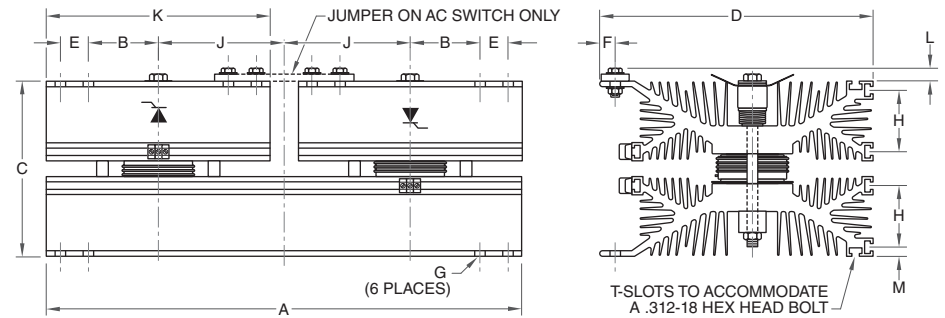

Dim.	Inches	Millimeters
A	17.06 Max.	433.32 Max.
B	2.5	63.5
C	6.3 Max.	160.02 Max.
D	9.86 Max.	250.95 Max.
E	1.0	25.4
F	0.75 Ref.	19.05 Ref.
G	0.375 Dia.	9.525 Dia.
H	2.16 Ref.	54.86 Ref.
J	4.5 Ref.	114.3 Ref.
K	8.0 Ref.	203.2 Ref.
L	0.5 Max.	12.7 Max.
M	0.33 Ref.	8.38 Ref.

5 PAAATA200616, PAAATA200618, PAAATA201216, PAAATA201218, PAAATA201616, PAAATA201618, PDAARA200636, PDAARA201236, PDAARA201636, PDAATARA0618, PDAATARA1218, PDAATARA1618, PDAATA200618, PDAATA201218, PDAATA201618

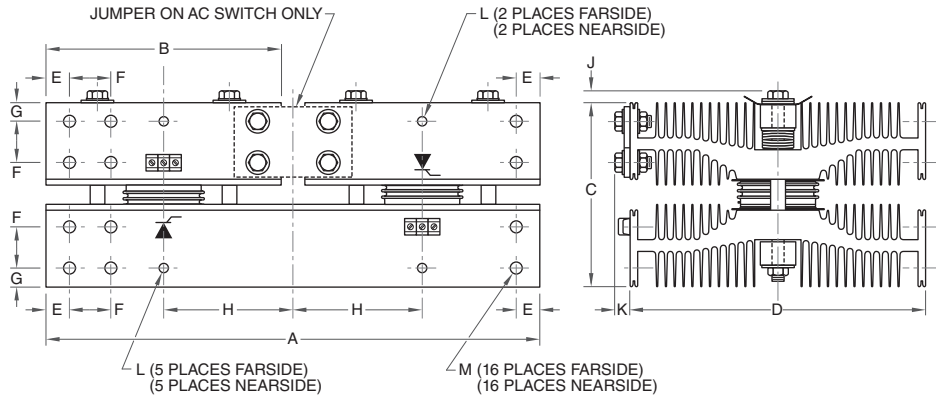

Dim.	Inches	Millimeters
A	21.06 Max.	534.92 Max.
B	10.0 Ref.	254.0 Ref.
C	7.89 Max.	200.4 Max.
D	12.69 Max.	322.33 Max.
E	1.0	25.4
F	1.75	44.45
G	0.81	20.57
H	5.50	139.7
J	0.58 Ref.	14.73 Ref.
K	0.65 Ref.	16.51 Ref.

6 PAB1CD430890, PAB1CD431290, PAB1CD431690

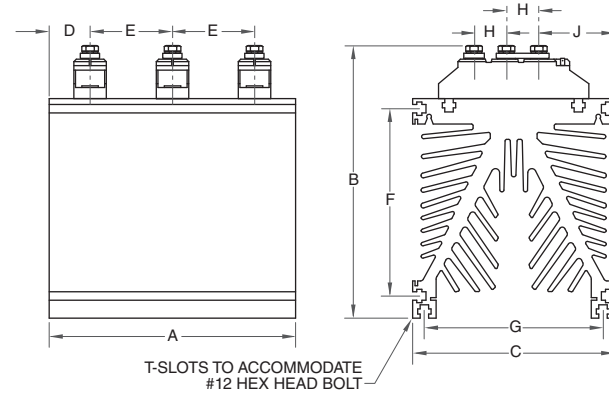

Dim.	Inches	Millimeters
A	6.0	152.5
B	7.0 Max.	177.83 Max.
C	4.92 Max.	125.0 Max.
D	1.0	25.4
E	2.0	50.8
F	4.53	115.06
G	4.33	109.98
H	0.79	20.07
J	1.5	31.1

7

PDB1CD410899, PDB1CD411299, PDB1CD411699,
PDB1CD420890, PDB1CD421290, PDB1CD421690,
PDB1CD430890, PDB1CD431290, PDB1CD431690

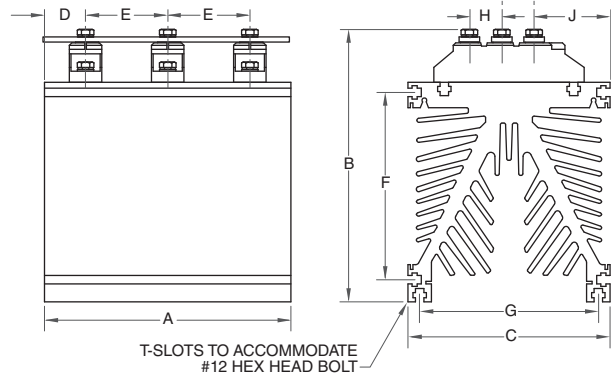

Dim.	Inches	Millimeters
A	6.0	152.5
B	7.0 Max.	177.83 Max.
C	4.92 Max.	125.0 Max.
D	1.0	25.4
E	2.0	50.8
F	4.53	115.06
G	4.33	109.98
H	0.79	20.07
J	1.5	31.1

8

PAB2CD630815, PAB2CD631215, PAB2CD631615

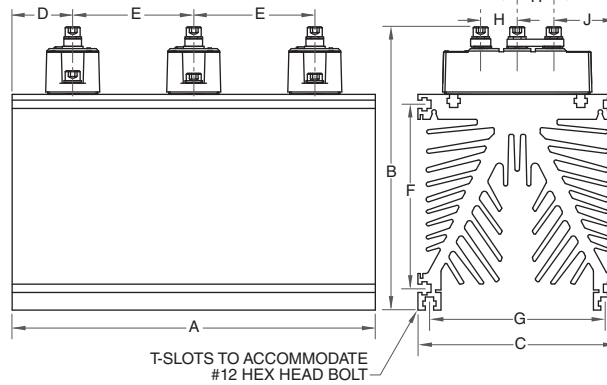

Dim.	Inches	Millimeters
A	9.0	228.6
B	7.0 Max.	177.83 Max.
C	4.92 Max.	125.0 Max.
D	1.5	31.1
E	3.0	76.2
F	4.53	115.06
G	4.33	109.98
H	0.91	23.11
J	1.56	39.62

9

PDB2CD610816, PDB2CD611216, PDB2CD611616,
PDB2CD620815, PDB2CD621215, PDB2CD621615,
PDB2CD630815, PDB2CD631215, PDB2CD631615

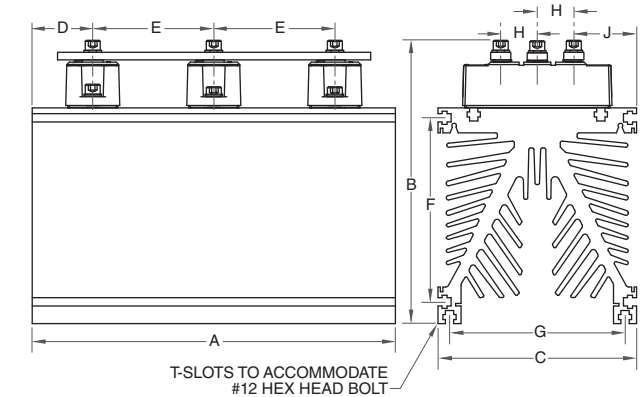

Dim.	Inches	Millimeters
A	9.0	228.6
B	7.0 Max.	177.83 Max.
C	4.92 Max.	125.0 Max.
D	1.5	31.1
E	3.0	76.2
F	4.53	115.06
G	4.33	109.98
H	0.91	23.11
J	1.56	39.62

DC-DC
ConvertersGate Drivers
& IPM
InterfaceCustom
ModulesIGBT
Assemblies**Assemblies**Fast Recovery
Diode ModulesThyristor &
Diode
ModulesDiscrete
RectifiersDiscrete
Thyristors

DIPIPM

IPMs

MOSFET
ModulesHybrid
& SiC
Modules

IGBTs

10 PAB3ND430825, PAB3ND431225, PAB3ND431625

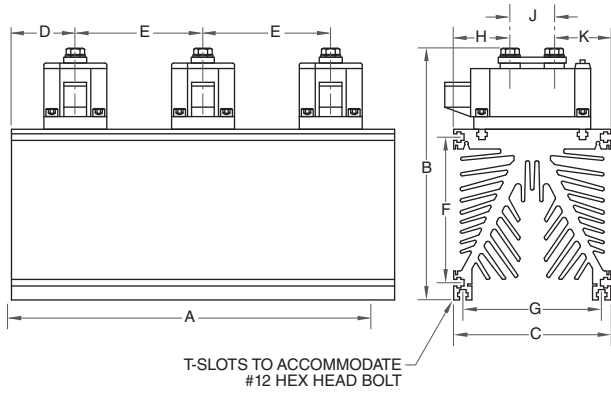

Dim.	Inches	Millimeters
A	12.0	304.8
B	8.0 Max.	203.2 Max.
C	4.92 Max.	125.0 Max.
D	2.0	50.8
E	4.0	101.6
F	4.53	115.06
G	4.33	109.98
H	1.7	43.18
J	1.38	35.05
K	1.77	44.96

11 PDB3ND410826, PDB3ND411226, PDB3ND411626,
PDB3ND420825, PDB3ND421225, PDB3ND421625,
PDB3ND430625, PDB3ND431225, PDB3ND431625

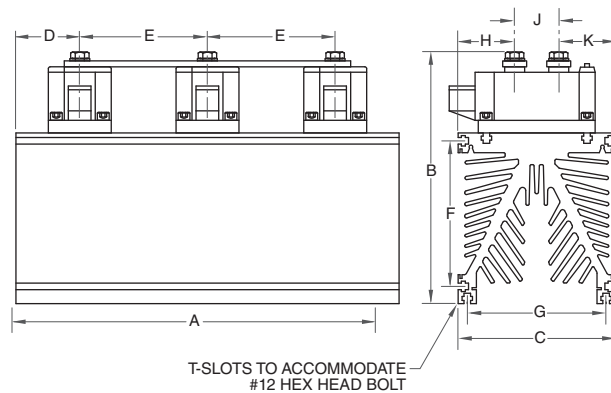

Dim.	Inches	Millimeters
A	12.0	304.8
B	8.0 Max.	203.2 Max.
C	4.92 Max.	125.0 Max.
D	2.0	50.8
E	4.0	101.6
F	4.53	115.06
G	4.33	109.98
H	1.7	43.18
J	1.38	35.05
K	1.77	44.96

12 PAB2LD430850, PAB2LD431250, PAB2LD431650,
PDB2LD410860, PDB2LD411260, PDB2LD411660,
PDB2LD420850, PDB2LD421250, PDB2LD421650,
PDB2LD430850, PDB2LD431250, PDB2LD431650

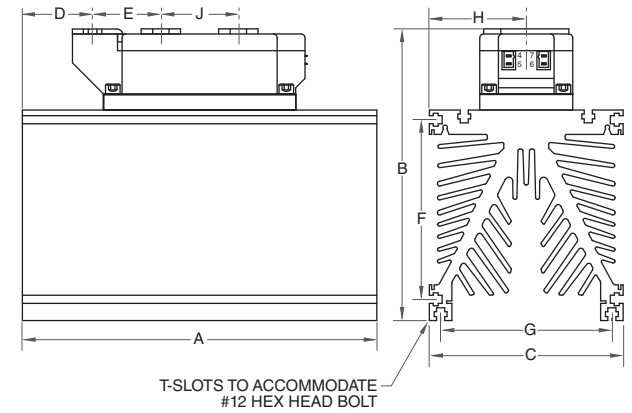

Dim.	Inches	Millimeters
A	9.0	228.6
B	8.0 Max.	203.2 Max.
C	4.92 Max.	125.0 Max.
D	1.78	45.21
E	1.73	43.94
F	4.53	115.06
G	4.33	109.98
H	2.46	62.48
J	1.97	50.04

MEDIUM VOLTAGE SCR & RECTIFIER ASSEMBLIES

Powerex is your source for Medium Voltage SCR and rectifier assemblies in a wide range of ratings and configurations.

Applications Include:

- Motor Controls - Medium Voltage Converters
 - SCR power bridges for solid state starters
 - SCR based input rectifiers
 - Crowbar systems for motor drives
- Wind Power (Alternative Energy)
 - Converters available as diodes or SCRs
 - static var compensation
- Resistance Heating
- Inductive Heating - Input Rectifiers
- Load Commutated Inverter Power Section for Retrofits
- Uninterruptible Power Supplies - SCR Transfer Switches and Input Rectifiers
- Mining - SCR Power Bridges, Solid State Starters and Input Rectifiers
- Power Distribution - SCR Based Switches
- Thyristor Controlled Reactors

Powerex complements its rectifier products with IGBT assemblies for inverters, converters, choppers, and full or half wave bridge units. These assemblies can also be combined to provide a system-wide solution.

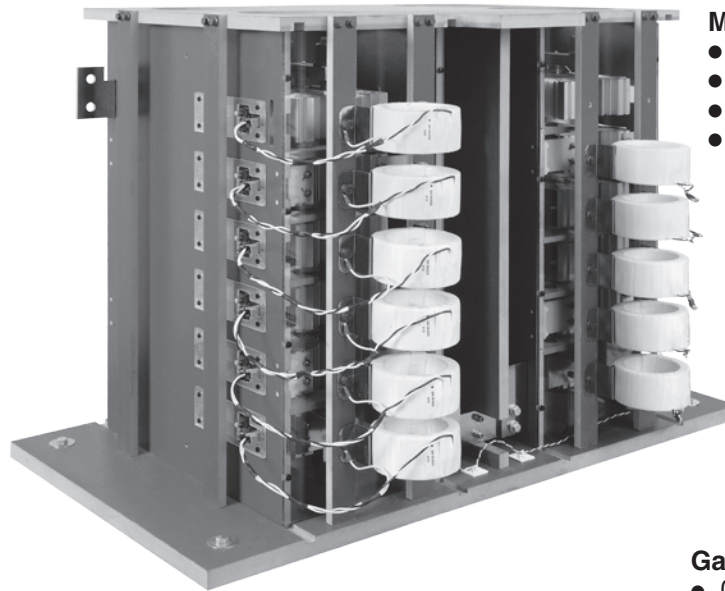

MV SCR Power Stack

- 5MW, 24kV SCR based power section
- Designed for low partial discharge (low corona)
- Scalable to other voltage and current ratings
- Air cooled, modular design



Gate Power Supply

- Current loop supplies power to all the SCR levels
- Provides excellent voltage isolation between SCRs and controls and also provides high BIL capability

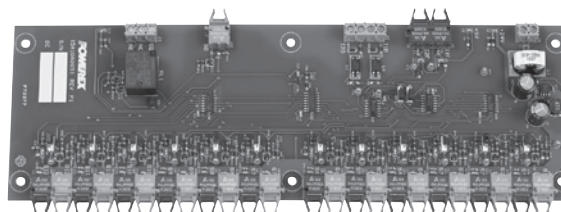

Fiber Optic Fan Out Board

- Receives SCR gate commands from external controller
- Fans out command to multiple level of SCRs
- Receives and processes feedback from gate boards

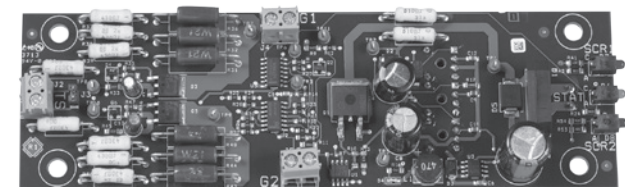

MV Fiber Optic SCR Gate Drive Board

- Receives and conditions power from an isolated loop power supply current transformer, allowing for high voltage isolation
- Provides fiber optic triggering of gates
- Provides fiber optic status feedback for temperature and power supply health monitoring

How to Select the Proper Assembly for Your Needs

Areas to consider when selecting the proper assembly.

Application: _____

Type of Circuit:

Single-Phase Bridge

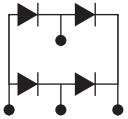

Single-Phase Half Controlled Bridge

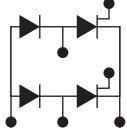

Single-Phase Full Controlled Bridge

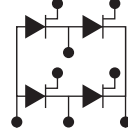

Three-Phase Bridge

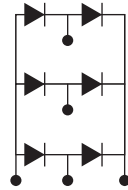

Three-Phase Half Controlled Bridge

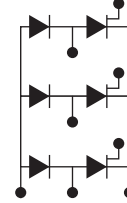

Three-Phase Full Controlled Bridge

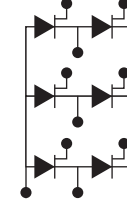

Power Topology: _____

Electrical parameters:

- Source MVA: _____
- Maximum Continuous Output Current (Amps): _____
- Maximum Overload:
 - Output DC Current (Amps): _____
 - Overload Duration (Sec): _____
- Input Voltage (Volts) _____
(VAC-RMS for Single Phase, VAC-RMS line-to-line for Three-Phase)
- Line Frequency:
 - 50 Hertz or 60 Hertz Other _____ Hz
- Distance to Source: _____
- Distance to Load: _____

Environmental Parameters:

- Maximum Ambient Temperature (°C): _____
- Humidity (0-95% Non-Condensing): _____
- Maximum Altitude (Feet Above Sea Level): _____ ft

Please email this information to our IPP Department at ipp@pwr.com.
A Powerex engineer will review the information and contact you to discuss your assembly needs.

IGBT ASSEMBLIES

A leading supplier of IGBTs and other high power semiconductor applications, Powerex also produces POW-R-PAKs™, configurable IGBT power assemblies.

POW-R-PAK-GenII™

Powerex part numbers beginning with the prefix “NX” denote a GenII version of POW-R-PAK, which are recommended for new designs.

Applications Include:

- Distributed Power Generation
- Energy Storage
- Industrial Power Supplies
- Motor Drives
- Power Quality

Basic Circuit Configurations:

- Chopper
- Half-Bridge
- H-Bridge
- Three-Phase Bridge

Additional Available Options:

- Application Specific
- Blower/Fan
- Capacitor Banks

Note: Custom IGBT Assemblies Also Available

TABLE OF CONTENTS

Numbering System	K-2
600V & 1200V 3-Phase Assemblies	K-4
600V & 1200V H-Bridge Assemblies	K-5
Outline Drawings	K-6

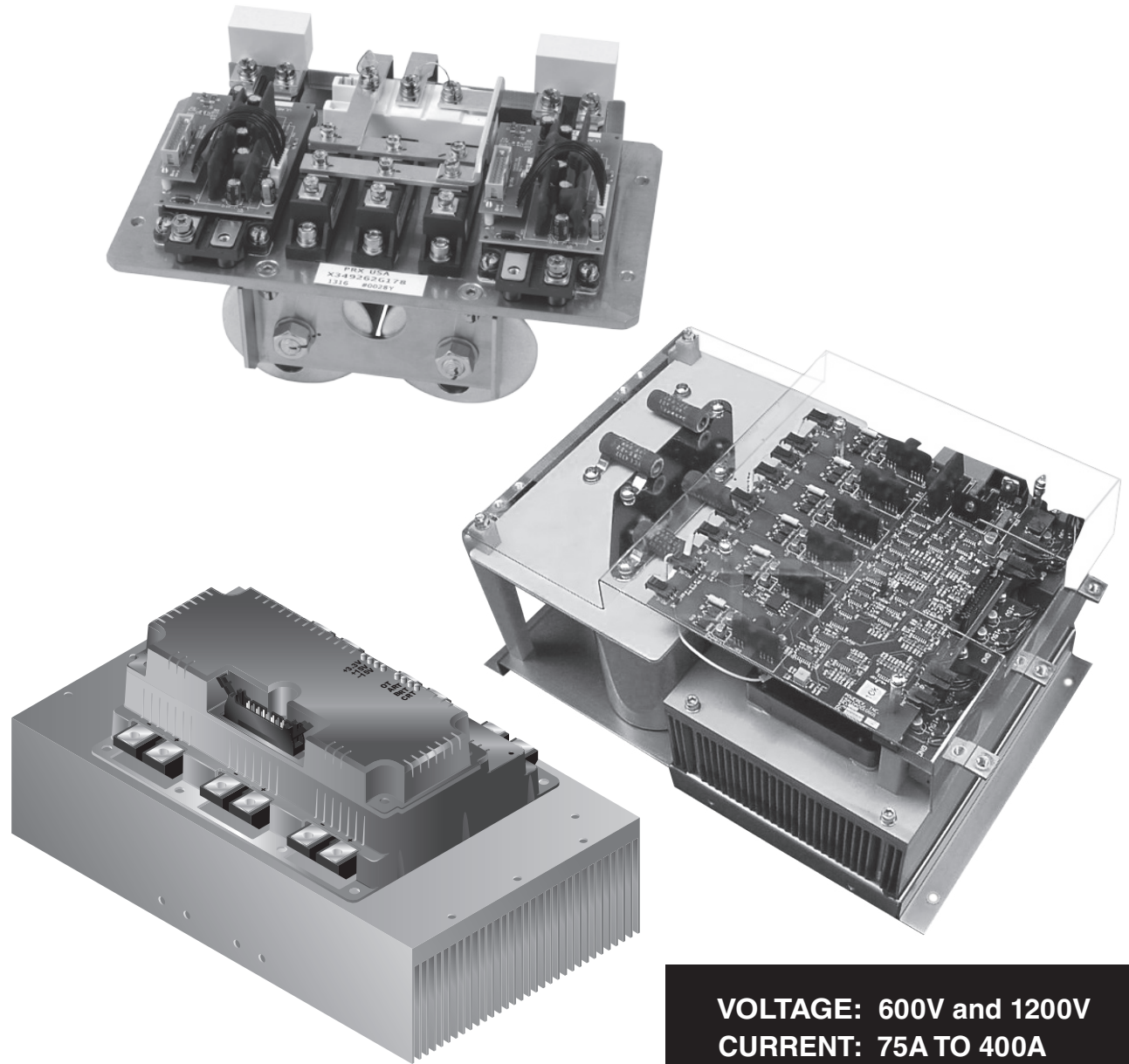

VOLTAGE: 600V and 1200V
CURRENT: 75A TO 400A

IGBT NX Series IGBT Assembly Overview

To help determine the proper IGBT assembly for your application, the following information is needed.

(1) Type NX Series IGBTs:

Air Cooled – Is a fan required?

Liquid Cooled – Type of liquid cooling: water or glycol.

(2) Power:

Single-Phase

Input (VDC) _____

Output Freq. _____

Output (VAC) _____

Output Current (AAC) _____

Three-Phase

Input (VDC) _____

Output Freq. _____

Output (VAC) _____

Output Current (AAC) _____

(3) Ambient Temperature (°C)

(4) Switching Frequency (kHz)

(5) Circuit Configuration:

Chopper H-Bridge

Half-Bridge Three-Phase Bridge

(6) Options:

Blower / Fan

Electrolytic Capacitors at 50 µfd/Amp

Film Capacitors at 20 µfd/Amp

No Cap Bank

Application Specific

(7) Assembly:

Prototype

Production - Estimated Annual Volume

Please email this information to our IPP Department at ipp@pwr.com.

A Powerex engineer will review the information and contact you to discuss your assembly needs.

NX Numbering System*

NXD1K2A200A50-XX is a 200KVA IGBT air cooled half-bridge assembly using IGBTs rated at 1200 Volts AC.

NX D 1K2 A 200 A 50 – XX

(1) (2) (3)(4)(5) (6) (7)(8)(9) (10) (11)(12) (13)(14)

(1) Type:

NX = NX Series IPP Assembly

(7)(8)(9) KVA Rating

001 to 999

1K0 to 9K2

(2) Circuit Configuration:

H = Single Brake

D = Half-Bridge

B = H-Bridge

T = Three-Phase Bridge

R = Three-Phase + Brake

E = Chopper

i.e. 200 = 200KVA

i.e. 1K2 = 1200KVA

(10) Thermal Management

A = Air Cooled

W = Liquid Cooled

(3)(4)(5) Voltage

001 to 999

1K0 to 9K9

i.e. 600 = 600V

i.e. 1K2 = 1200V

i.e. 1K7 = 1700V

(11)(12) Ambient Temperature

STD 40°C

Options 50°C

>50°C Consult Factory

(13)(14) Options

01 to 99

(6) Voltage Type

A = AC (Active Front End)

D = DC

*Powerex is in the process of launching Gen II POW-R-PAK™ IGBT Assemblies. Powerex part numbers beginning with the prefix "NX" denote a Gen II version of POW-R-PAK, which are recommended for new designs.

IGBT PP Series IGBT Assembly Overview

To help determine the proper IGBT assembly for your application, the following information is needed.

(1) Type PP Series IGBTs:

Air Cooled – Is a fan required?

Liquid Cooled – Type of liquid cooling: water or glycol.

(2) Power:

Single-Phase

Input (VDC) _____

Output Freq. _____

Output (VAC) _____

Output Current (AAC) _____

Three-Phase

Input (VDC) _____

Output Freq. _____

Output (VAC) _____

Output Current (AAC) _____

(3) Ambient Temperature (°C)

(4) Switching Frequency (kHz)

(5) Circuit Configuration:

Chopper H-Bridge

Half-Bridge Three-Phase Bridge

(6) Options:

Blower / Fan

Electrolytic Capacitors at 50 µfd/Amp

Film Capacitors at 20 µfd/Amp

Application Specific

(7) Assembly:

Prototype

Production - Estimated Annual Volume

Please email this information to our IPP Department at ipp@pwr.com.

A Powerex engineer will review the information and contact you to discuss your assembly needs.

PP Numbering System

PP400B060-ND is a 400A IGBT H-Bridge assembly using IGBTs rated at 600 Volts AC.

PP 400 B 060 – ND

(1) (2) (3) (4) (5)

(1) Type:

PP = PP Series IPP Assembly

(4) Voltage

060 = 600V

120 = 1200V

(2) Amperes

(5) Factory Designation

(3) Circuit Configuration:

B = H-Bridge

T = 3-Phase

600V and 1200V 3-Phase IGBT Assemblies,

(Refer to device datasheets at www.pwr.com for test conditions.)

MAXIMUM RATINGS (IGBT Inverter Sector)				ELECTRICAL CHARACTERISTICS (IGBT Part)									THERMAL CHARACTERISTICS			Outline Drawings	
Type	V _{CE(S)} Volts	I _C Amperes	V _{RMS} Isolation Volts	Typ. V _{CE(SAT)} Volts	V _{EC} Volts	I _{CE(S)} mA	V _{CC(Prot)} Volts	Inductive Load Switching Times				R _{th(c-f)} °C/W	IGBT R _{th(j-c)} °C/W	DIODES R _{th(j-c)} °C/W	Weight lbs		
								t _{d(on)} Ns	t _r Ns	t _{d(off)} Ns	t _{f(off)} Ns						
PP75T120-ND	1200	75	2500	2.4	3.8	1.0	900	100	50	400	300	0.19	0.22	0.29	24.4	1	K-6
PP150T120-ND	1200	150	2500	2.1	3.8	1.0	900	130	100	450	350	0.022	0.13	0.23	24.4	1	K-6
PP200T060-ND	600	200	2500	1.7	2.6	1.0	900	120	120	300	300	0.07	0.13	0.24	24.4	1	K-6
PP200T120-ND	1200	200	2500	3.0	3.8	1.0	900	130	100	450	350	0.022	0.093	0.17	24.4	1	K-6
PP300T060-ND	600	300	2500	3.0	3.8	1.0	400	550	190	600	350	0.02	0.066	0.12	24.4	1	K-6
PP300T120-ND	1200	300	2500	2.4	3.2	1.0	800	300	80	500	300	0.02	0.05	0.08	33.7	2	K-6

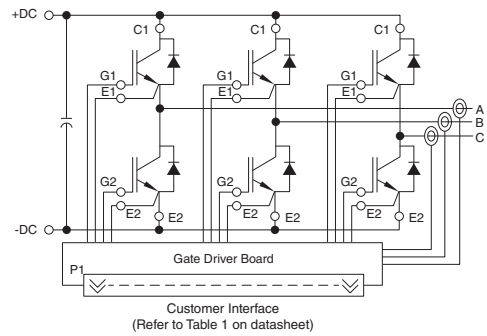

600V and 1200V H-Bridge IGBT Assemblies,

(Refer to device datasheets at www.pwr.com for test conditions.)

MAXIMUM RATINGS (IGBT Inverter Sector)				ELECTRICAL CHARACTERISTICS (IGBT Part)									THERMAL CHARACTERISTICS			Outline Drawings	
Type	V _{CE(S)} Volts	I _C Amperes	V _{RMS} Isolation Volts	Typ. V _{CE(SAT)} Volts	V _{EC} Volts	I _{CES} mA	V _{CC(Prot)} Volts	Inductive Load Switching Times				R _{th(c-f)} °C/W	IGBT R _{th(j-c)} °C/W	DIODES R _{th(j-c)} °C/W	Weight lbs		
								t _{d(on)} Ns	t _r Ns	t _{d(off)} Ns	t _{f(off)} Ns						
PP100B120-ND	1200	100	2500	2.1	3.8	1.0	900	100	70	400	350	0.022	0.19	0.34	23	3	K-6
PP150B120-ND	1200	150	2500	2.1	3.8	1.0	900	120	120	300	300	0.022	0.13	0.23	23	3	K-6
PP200B120-ND	1200	200	2500	3.0	3.8	1.0	900	130	100	450	350	0.022	0.093	0.17	23	3	K-6
PP400B060-ND	600	400	2500	3.0	3.8	1.0	400	550	180	600	350	0.02	0.046	0.085	32	4	K-7

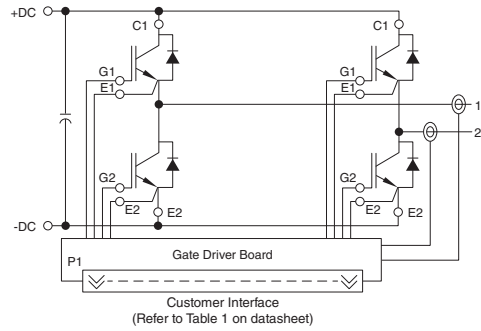

1 PP75T120-ND, PP150T120-ND, PP200T060-ND,
PP200T120-ND, PP300T060-ND

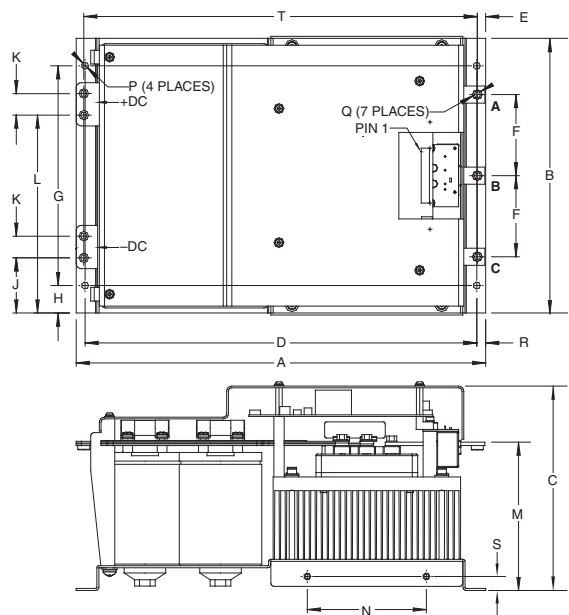

2 PP300T120-ND

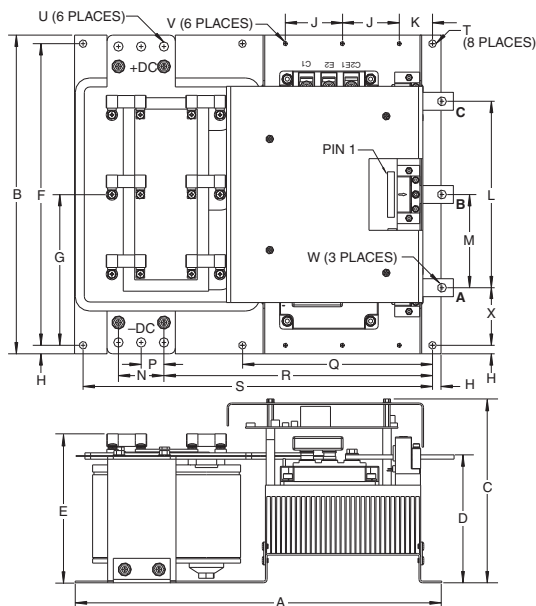

3 PP100B120-ND, PP150B120-ND, PP200B120-ND

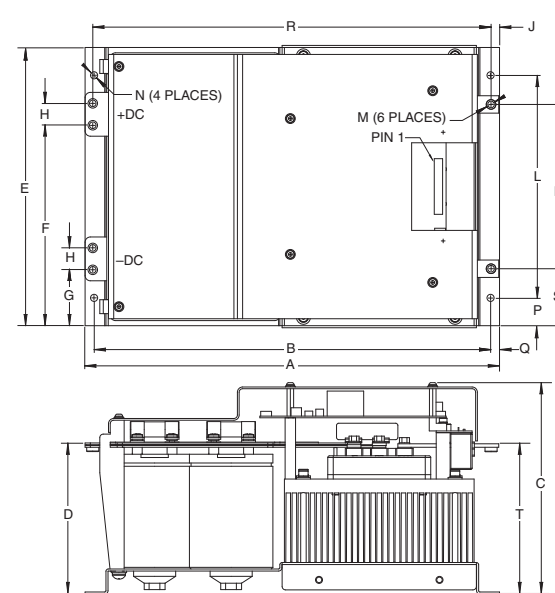

Dim.	Inches	Millimeters
A	14.9	378.4
B	10.15	257.8
C	7.4	193.0
D	14.25	362.0
E	0.3	7.7
F	2.95	75.0
G	8.0	203.2
H	1.0	25.4
J	2.01	51.0

Dim.	Inches	Millimeters
K	0.79	20.0
L	7.20	183.0
M	5.4	137.2
N	4.33	110.0
P	0.256 Dia.	6.5 Dia.
Q	M6 Metric	M6
R	0.32	8.2
S	0.51	12.9
T	14.32	363.6

Dim.	Inches	Millimeters
A	16.1	408.9
B	14.0	355.6
C	8.1	205.1
D	5.62	142.7
E	6.54	166.1
F	13.25	336.6
G	6.63	168.3
H	0.38	9.5
J	2.5	63.5
K	1.46	37.1
L	8.19	208.0

Dim.	Inches	Millimeters
M	4.09	104.0
N	2.0	50.8
P	1.0	25.4
Q	8.35	212.09
R	11.8	299.7
S	15.35	389.9
T	0.335 Dia.	8.5 Dia.
U	0.413 Dia.	10.5 Dia.
V	M5 Metric	M5
W	0.394 Dia.	10.0 Dia.
X	2.53	64.3

Dim.	Inches	Millimeters
A	14.9	378.4
B	14.25	362.0
C	7.6	193.0
D	5.43	138.0
E	10.15	257.8
F	7.2	183.0
G	2.01	51.0
H	0.79	20.0
J	0.3	7.7

Dim.	Inches	Millimeters
K	5.91	150.0
L	8.0	203.2
M	M6 Metric	M6
N	0.256 Dia.	6.5 Dia.
P	1.0	25.4
Q	0.32	8.2
R	14.32	363.6
S	2.05	52.0
T	5.4	137.1

4 PP400B060-ND

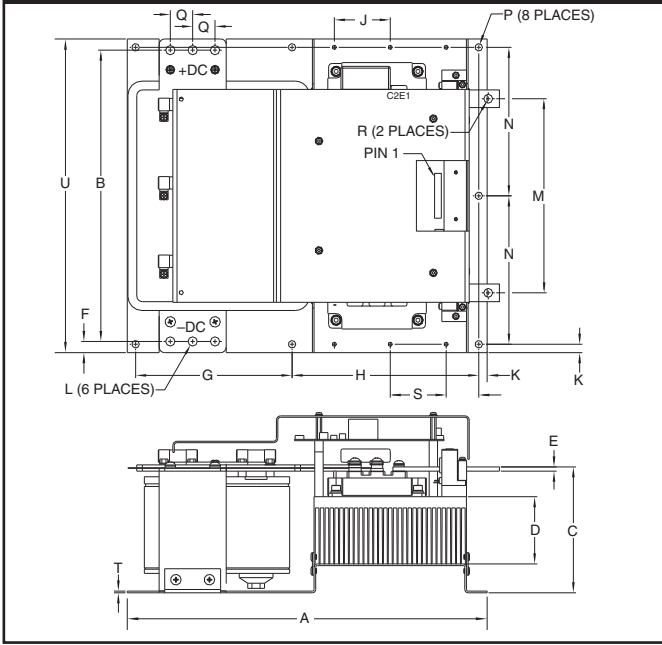

Dim.	Inches	Millimeters	Dim.	Inches	Millimeters
A	16.1	408.9	L	0.41 Dia.	10.5 Dia.
B	13.0	330.2	M	8.66	220.0
C	5.62	142.6	N	6.63	168.3
D	3.0	76.2	P	0.33 Dia.	8.5 Dia.
E	0.19	4.8	Q	1.0	25.4
F	0.5	12.7	R	0.39 Dia.	10.0 Dia.
G	7.0	177.8	S	1.46	37.1
H	8.35	212.1	T	0.07	1.9
J	2.5	63.5	U	14.0	355.6
K	0.38	9.5			

CUSTOM MODULES (Commercial / Moisture Resistant / Hermetic)

Capabilities:

Customers looking for application specific custom power modules benefit from Powerex's years of experience in chip manufacturing and design / engineering. Powerex custom power modules employ performance proven features. Soldered-down and wire bonding fabrication and compression bonded encapsulation (CBE) of SCR / Diode elements offer increased switching speeds, lower losses, more efficient cooling and higher power handling capabilities.

Reliability / Qualification Testing:

Reliability and qualification testing can be performed in accordance to military specifications, including Group A, B and C and specific customer requirements.

Features:

- Different Circuit Configurations (i.e. Common Emitter, Chopper)
- Different Termination Styles (i.e. Thicker Bus Bars, D-sub Connectors, Press On Pins, etc.)
- Extended Temperature Range, -55°C to 200°C
- Hermetic Modules
- High Voltage Isolation
- Integrated Heatsinks – Both Air and Liquid Cooled by Eliminating the Baseplate
- Larger Free-wheel Diodes
- Low Module Weight
- Moisture Resistance
- Over-current Shutdown
- Package Height, Width and Length
- Temperature and Current Sense

Substrates:

- Alumina
- Aluminum Nitride
- BeO
- IMS

Die Technology:

- Diode
- FR Diode
- GTO
- HVIGBT
- IGBT
- MOSFET
- SCR
- SiC Diode
- SiC MOSFET

Packages:

- Custom Development for Both Plastic and Hermetic Packages
- Picture Frame
- Standard IGBT Cases

For more information:

visit: <http://www.pwrx.com/summary/custom-power-modules.aspx>

email: globalsales@pwrx.com

phone: 724-925-7272, Option 3 (Applications Engineering Assistance)

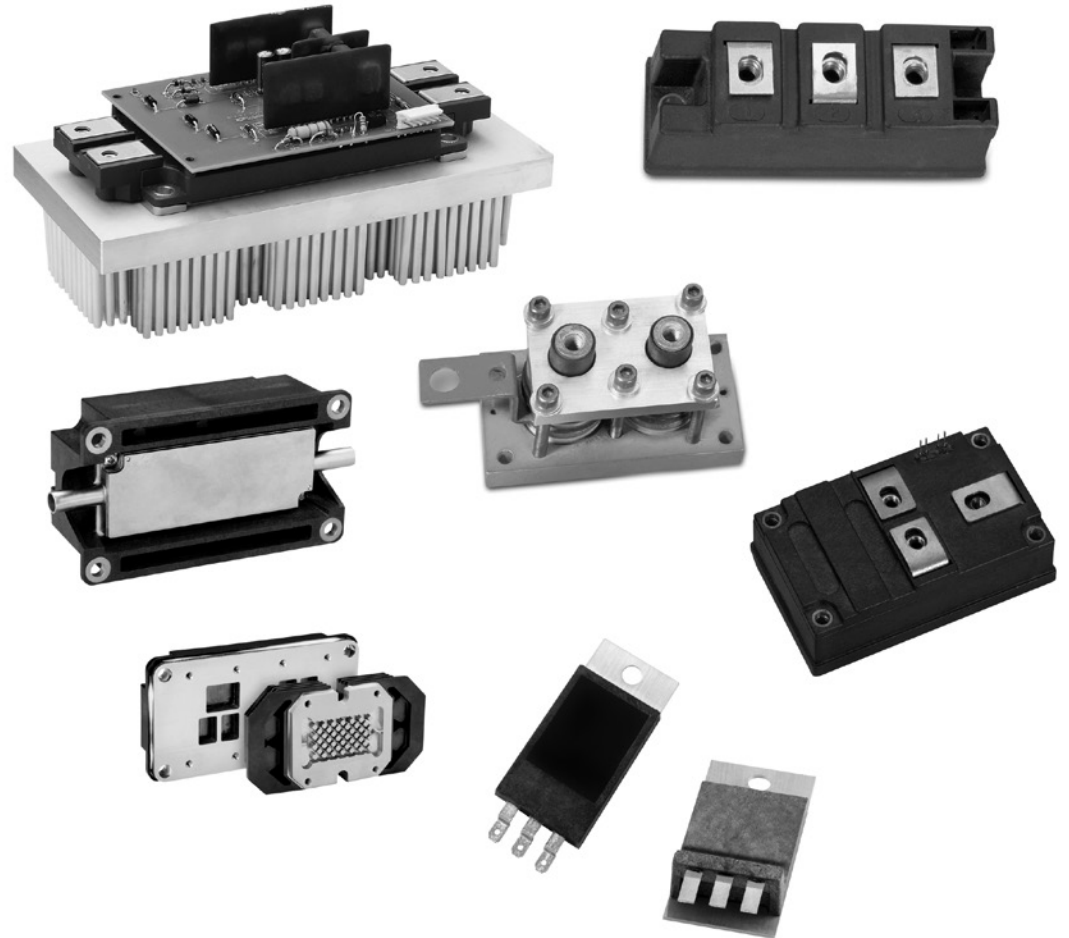

VOLTAGE: 30V TO 15,000V
CURRENT: 50A TO 1600A

DC-DC
Converters

Gate Drivers
& IPM
Interface

**Custom
Modules**

IGBT
Assemblies

Assemblies

Fast Recovery
Diode Modules

Thyristor &
Diode
Modules

Discrete
Rectifiers

Discrete
Thyristors

DIPIPM

IPMs

MOSFET
Modules

Hybrid
& SiC
Modules

IGBTs

GATE DRIVERS & IPM INTERFACE

Applications Include:

- IGBT Gate Driver Development Kit
- TRIAC Trigger
- IPM Interface

Packages:

- DIP
- PCB
- SIP
- SMT/SOP
- TO-92S

TABLE OF CONTENTS

IGBT Gate Drivers	M-2
IGBT Gate Driver Development Kits	M-4
IPM Interface Board	M-4
Silicon Bilateral Switch	M-4
Outline Drawings	M-5

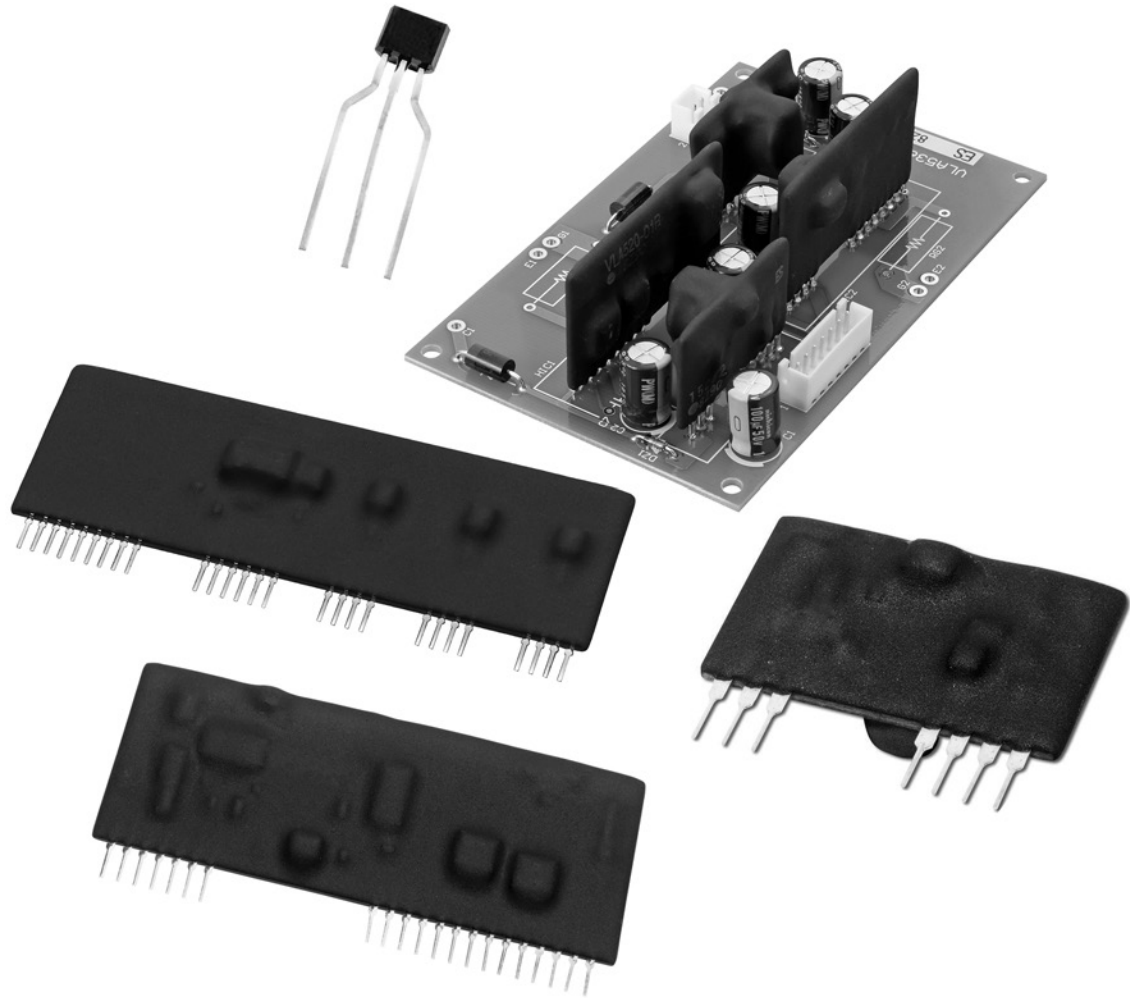

DC-DC
Converters

**Gate Drivers
& IPM
Interface**

Custom
Modules

IGBT
Assemblies

Assemblies

Fast Recovery
Diode Modules

Thyristor &
Diode
Modules

Discrete
Rectifiers

Discrete
Thyristors

DIPIM

IPMs

MOSFET
Modules

Hybrid
& SiC
Modules

IGBTs

IGBT Gate Drivers, (Refer to device datasheets at www.pwr.com for test conditions.)

Type	Integral DC-to-DC Converter	Short-circuit Protection	Soft Shutdown	Input Voltage (Volts)	Output Voltage (Volts)	Output Current (Amperes)	Usable Range	Optimum Range	Outline Drawings Number	Page
M57962K	No	V _{CE} Desaturation	Yes			±5	600V, 600A, 1200V 600A, 1700V, 400A	1700V, 400A	10	M-8
M57159L	No	V _{CE} Desaturation	Yes				600V, 150A 1200V, 75A	600V, 75A 1200V, 50A	1	M-5
VLA500-01	Yes	V _{CE} Desaturation	Yes – Adjustable	15V	+15V/-8V	±12	600V, 800A 1200V, 1400A	600V, 800A 1200V, 1400A	5	M-6
VLA500K-01R	Yes	V _{CE} Desaturation	Yes Adjustable	15V	+15V/-8V	±12	1700V, 2400A	1700V, 2400A	6	M-6
VLA502-01	Yes	V _{CE} Desaturation	Yes – Adjustable	15V	+15V/-8V	±12	600V and 1200V High Frequency NFH-series Modules		5	M-6
VLA503-01	No	V _{CE} Desaturation	Yes			±5	600V, 600A 1200V, 600A	600V, 400A 1200V, 200A	2	M-5
VLA504-01	No	V _{CE} Desaturation	Yes			±3	600V, 400A 1200V, 200A	600V, 100A 1200V, 50A	2	M-5
VLA507-01	No	None	No			±3	600V, 200A 1200V, 150A	600V, 200A 1200V, 150A	3	M-5
VLA513-01	No	None	No			±5	600V, 600A 1200V, 400A	600V, 600A 1200V, 400A	4	M-6
VLA536-01R	Yes	V _{CE} Desaturation	Yes	15V	+15V/-8V	±5	All 600V and 1200V NX-Series Dual Modules	600V, 600A 1200V, 450A	8	M-7
VLA552-01R	Yes	V _{CE} Desaturation	Yes – Adjustable	15V	+15V/-8V	±24	1200V, 2500A 1700V, 1800A	All MPD and New MPD Modules 1200V, 2500A 1700V, 1800A	9	M-7
VLA553-01R	Yes	V _{CE} Desaturation	Yes – Adjustable	15V	+15V/-8V	±24	1200V, 2500A 1700V, 1800A	All MPD and New MPD Modules 1200V, 2500A 1700V, 1800A	11	M-8
VLA553-02R	Yes	V _{CE} Desaturation	Yes – Adjustable	15V	+15V/-8V	±24	1200V, 2500A 1700V, 1800A	All MPD and New MPD Modules 1200V, 2500A 1700V, 1800A	11	M-8
VLA567-01R	Yes	V _{CE} Desaturation	Yes – Adjustable	15V	+15V/-8V	±8	600V, 1000A 1200V, 1000A	600V, 1000A 1200V, 1000A	12	M-8

VLA500-01, VLA500K-01R

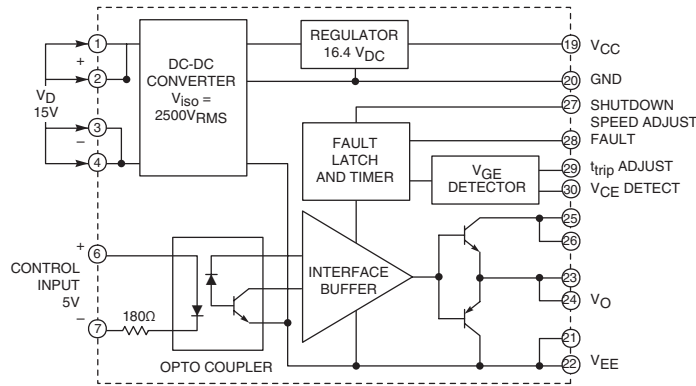

VLA502-01

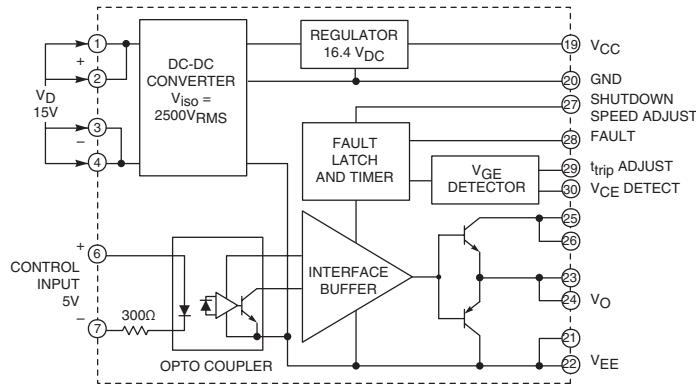

VLA552-01R

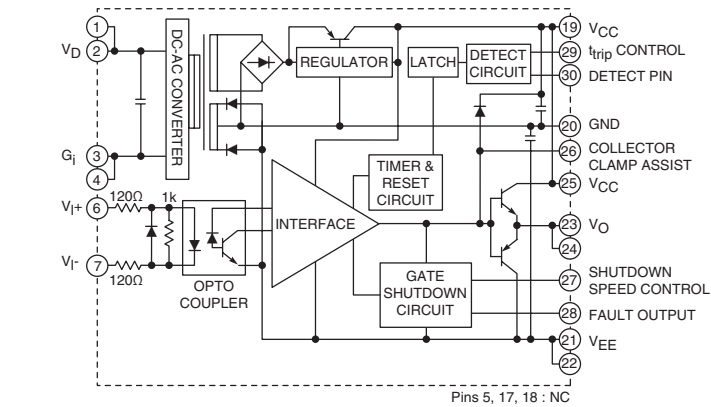

M57159L, M57962K, VLA503-01, VLA504-01

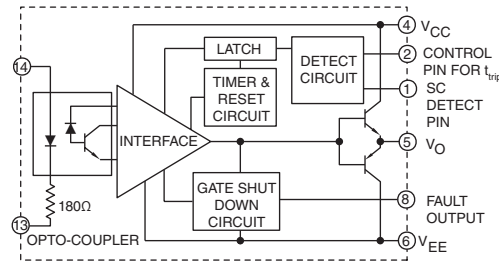

VLA507-01, VLA513-01

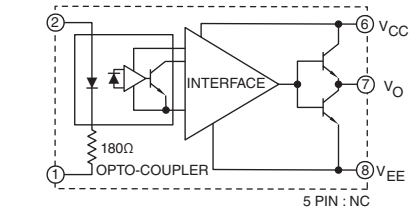

VLA536-01R

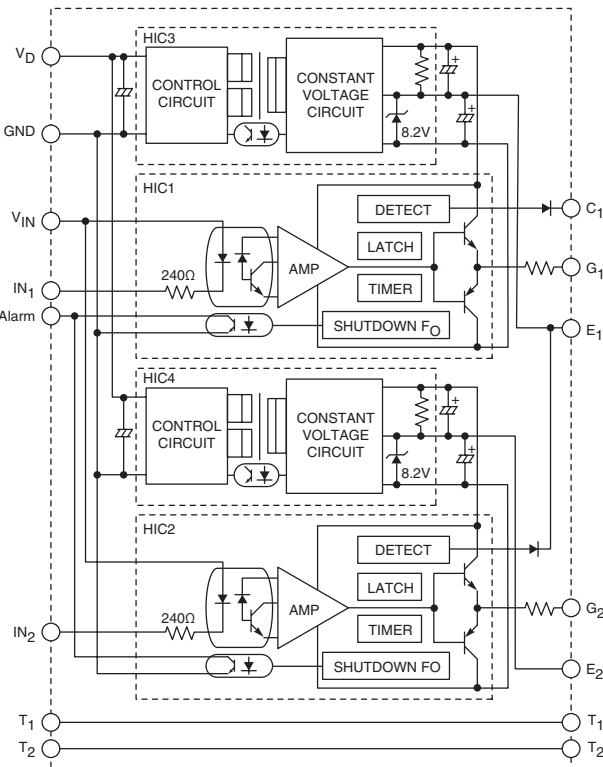

VLA553-01R, VLA553-02R

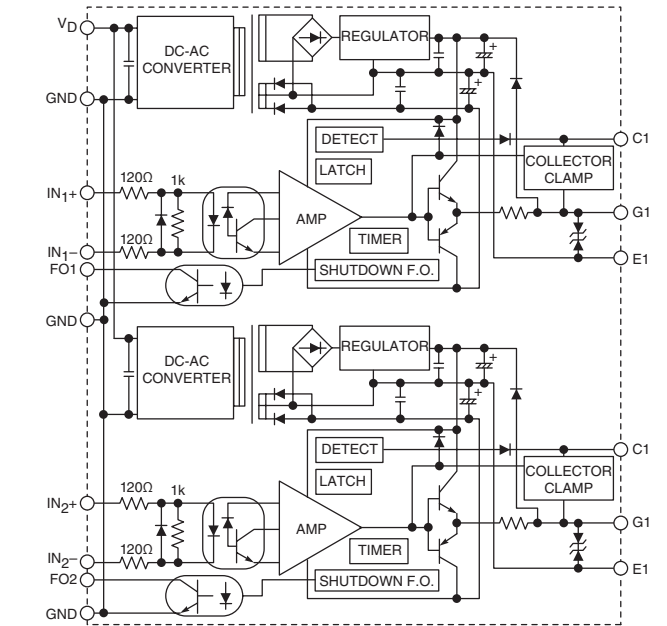

VLA567-01R

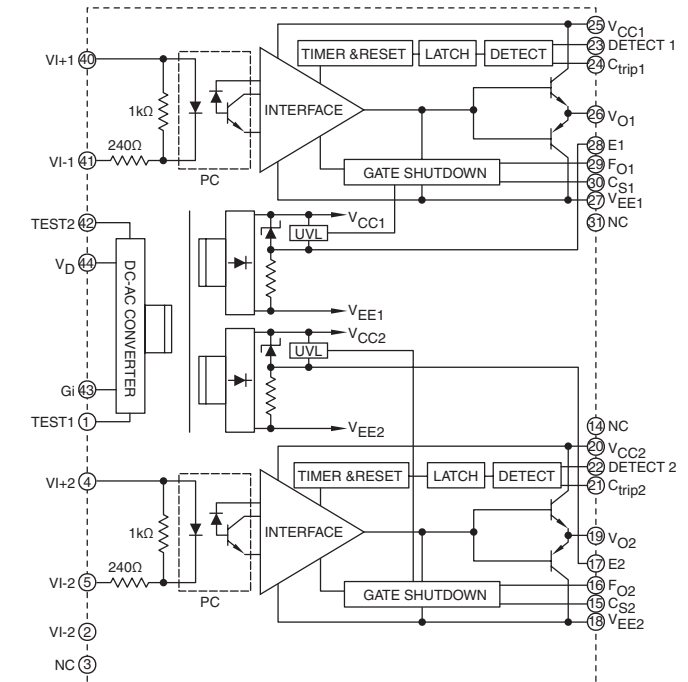

IGBT Gate Driver Development Kits

Part Number	Prototype Board*	Gate Driver Part Number*	Peak Drive Current Amperes	Minimum RG Ω	Desaturation Detection	Typical Module Rating Amperes	Recommended DC-to-DC Converter*
BG2B-1515	BG2B	M57159L-01	± 1.5	4.2	Yes	Up to 100A	VLA106-15242 (For 15VDC Input)
BG2B-3015	BG2B	VLA504-01	± 3.0	3.0	Yes	Up to 200A	
BG2B-5015	BG2B	VLA503-01	± 5.0	2.0	Yes	Up to 600A	VLA106-24242 (For 24VDC Input)
BG2C-3015	BG2C	VLA507	± 3.0	3.9	No	Up to 200A	
BG2C-5015	BG2C	VLA513	± 5.0	2.0	No	Up to 600A	
BG2A-NF	BG2A	VLA500-01	± 12.0	1.0	Yes	Up to 1400A	Included in Gate Driver
BG2A-NFH	BG2A	VLA502-01	± 12.0	1.0	Yes	Up to 600A NFH Series Devices	
BG2A-K	BG2A	VLA500K	± 12.0	1.0	Yes	1700V Up to 1000A	Included in Gate Driver
BG2D-5015	BG2D	VLA503-01	± 5.0	2.0	Yes	Up to 450A NX Series Duals	VLA106-15242
BG2E	BG2E	VLA500-01	± 12.0	1.0	Yes	Up to 1000A NXL Series Duals	Included in Gate Driver
BG2G-8015	BG2G	VLA567-01R	± 8.0	2.0	Yes	Up to 1000A	Included in Gate Driver

*Driver board come with parts noted here and are not assembled.

Silicon Bilateral Switch,

(Refer to device datasheet at www.pwr.com for test conditions.)

ELECTRICAL CHARACTERISTICS										Outline Drawings	
Type	I_T mA	I_G Amperes	V_S VS	P_T mW	I_S μA	I_H mA	V_T Volts	I_{GT} μA	V_{GT} μA	Number	Page
BS08D-T112	175	5	8	450	200	1.5	1.4	10	200	7	M-7

IPM Interface Board

Part Number	Prototype Board	Typical Module Rating Amperes	Recommended DC-to-DC Converter*
BP2B-V	BP2B-V	Up to 800A V1-Series IPM	VLA106-15151

1 M57159L

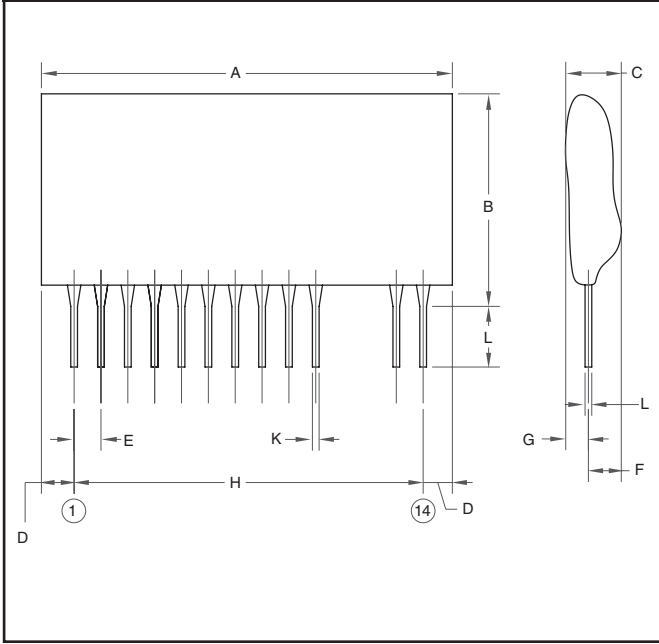

Dim.	Inches	Millimeters
A	1.70 Max.	43.0 Max.
B	0.87 Max.	22.0 Max.
C	0.43 Max.	11.0 Max.
D	0.22 Max.	5.5 Max.
E	0.10	2.54
F	0.34 Max.	8.5 Max.

2 VLA503-01, VLA504-01

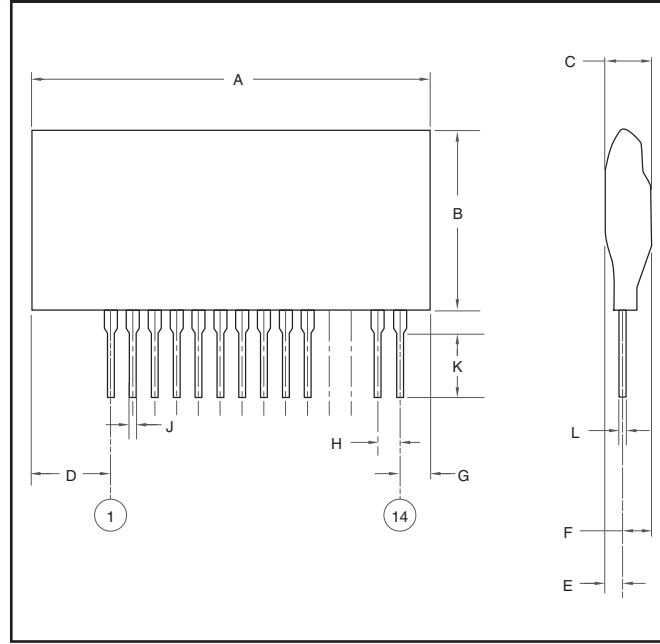

Dim.	Inches	Millimeters
A	2.0 Max.	51.0 Max.
B	1.02 Max.	26.0 Max.
C	0.4 Max.	10.0 Max.
D	0.45 Max.	11.5 Max.
E	0.12 Max.	3.0 Max.
F	0.3 Max.	7.5 Max.

3 VLA507-01

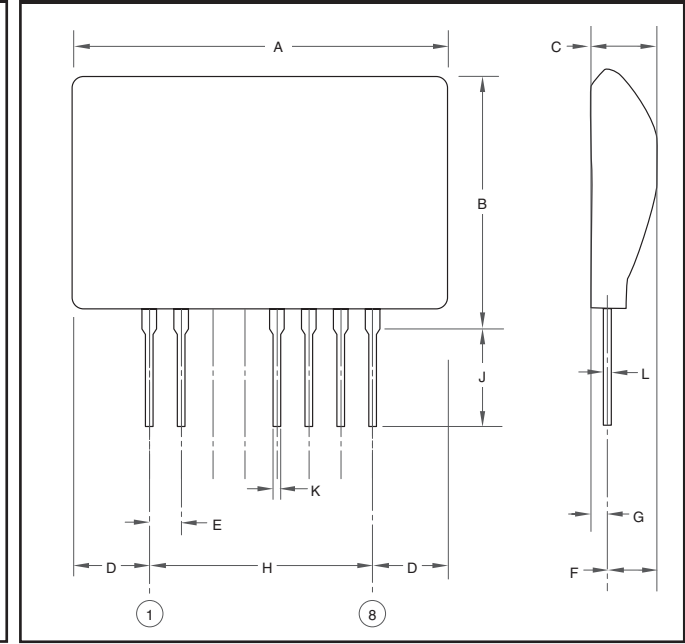

Dim.	Inches	Millimeters	Dim.	Inches	Millimeters
A	1.18 Max.	30.0 Max.	G	0.08 Max.	2.0 Max.
B	0.79 Max.	20.0 Max.	H	0.70	17.78
C	0.28 Max.	7.0 Max.	J	0.18±0.06	4.5±1.5
D	0.24 Max.	6.0 Max.	K	0.02	0.5
E	0.10	2.54	L	0.01	0.25
F	0.216 Max.	5.5 Max.			

4 VLA513-01

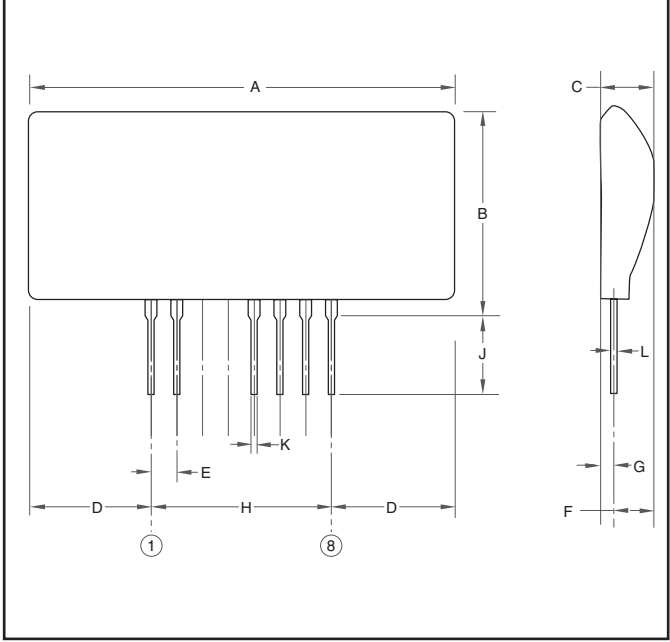

Dim.	Inches	Millimeters
A	1.85 Max.	47.0 Max.
B	1.063 Max.	27.0 Max.
C	0.28 Max.	7.0 Max.
D	0.59 Max.	15.0 Max.
E	0.10	2.54
F	0.216 Max.	5.5 Max.

Dim.	Inches	Millimeters
G	0.08 Max.	2.0 Max.
H	0.70	17.78
J	0.18±0.06	4.5±1.5
K	0.03	0.75
L	0.02	0.5

5 VLA500-01, VLA502-01

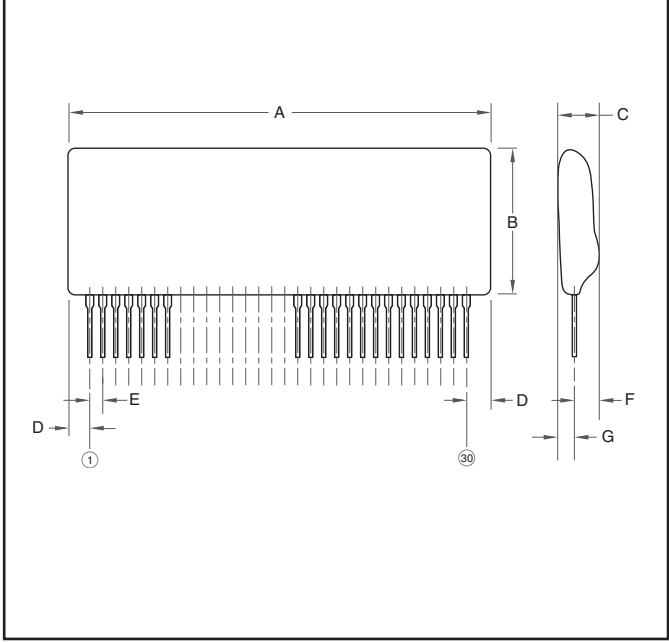

Dim.	Inches	Millimeters
A	3.27 Max.	83.0 Max.
B	1.30 Max.	33.0 Max.
C	0.61 Max.	15.5 Max.
D	0.20 Max.	5.0 Max.

Dim.	Inches	Millimeters
E	0.10	2.54
F	0.45 Max.	11.5 Max.
G	0.18 Max.	4.6 Max.

6 VLA500K-01R

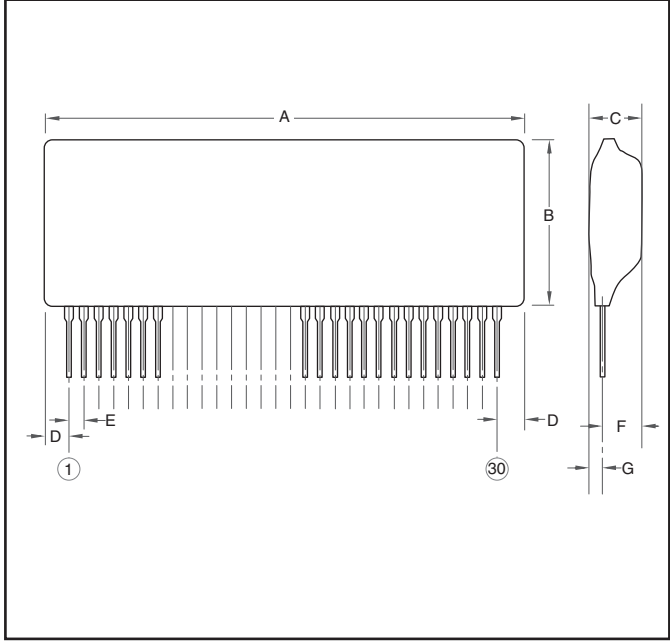

Dim.	Inches	Millimeters
A	3.27 Max.	83.0 Max.
B	1.30 Max.	33.0 Max.
C	0.67 Max.	17.0 Max.
D	0.20 Max.	5.0 Max.

Dim.	Inches	Millimeters
E	0.10	2.54
F	0.45 Max.	11.5 Max.
G	0.24 Max.	6.0 Max.

7 BS08D-T112

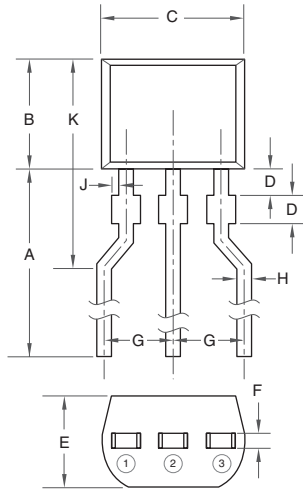

Dim.	Inches	Millimeters
A	0.55 Min.	14.0 Min.
B	0.12 Max.	3.0 Max.
C	0.16	4.0
D	0.39	1.0
E	0.098 Max.	2.5 Max.

Dim.	Inches	Millimeters
F	0.016	0.4
G	0.10	2.5
H	0.018	0.45
J	0.004	0.1
K	0.29 Max.	7.5 Max.

8 VLA536-01R

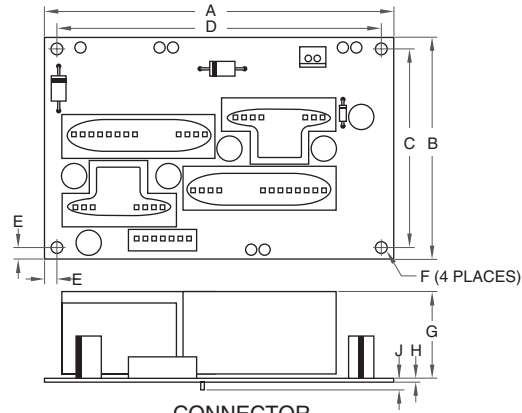

CONNECTOR

Pin	CN1	CN2
1	V _D	T ₁
2	GND	T ₂
3	NC	
4	Alarm	
5	IN ₁	
6	IN ₂	
7	V _{IN}	

Dim.	Inches	Millimeters
A	3.97±0.04	101.0±1.0
B	2.52±0.02	64.0±0.5
C	2.26	57.5
D	3.75	94.5
E	0.13	3.25

Dim.	Inches	Millimeters
F	0.12 Dia.	3.0 Dia.
G	1.14 Max.	29.0 Max.
H	0.06	1.6
J	0.12 Max.	3.0 Max.

9 VLA539-01R, VLA552-01R

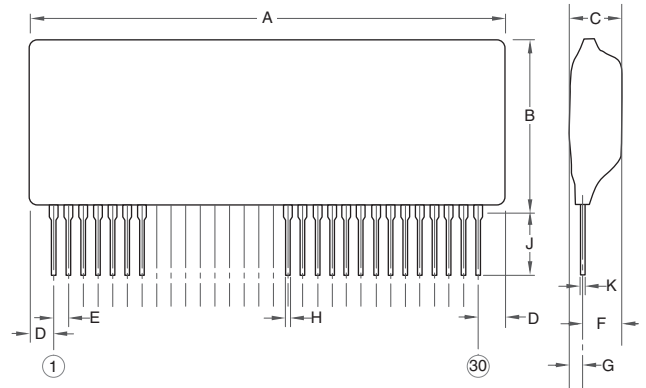

Dim.	Inches	Millimeters
A	3.46 Max.	88.0 Max.
B	1.65 Max.	42.0 Max.
C	0.67 Max.	17.0 Max.
D	0.31 Max.	8.0 Max.
E	0.1	2.54

Dim.	Inches	Millimeters
F	0.45 Max.	11.5 Max.
G	0.23 Max.	6.0 Max.
H	0.03±0.004	0.75±0.1
J	0.14±0.04	3.5±1.0
K	0.027 Max.	0.7 Max.

10 M57962K

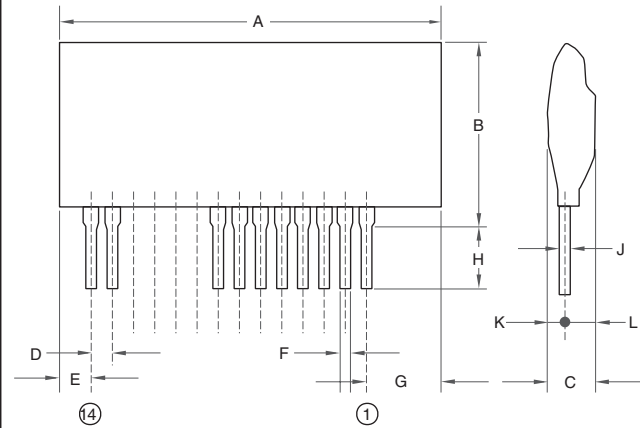

Dim.	Inches	Millimeters
A	2.0 Max.	51.0 Max.
B	1.06 Max.	27.0 Max.
C	0.4 Max.	10.0 Max.
D	0.10	2.54
E	0.26 Max.	6.5 Max.
F	0.02+0.006/-0.004	0.5+0.15/-0.1

Dim.	Inches	Millimeters
G	0.5 Max.	12.5 Max.
H	0.18±0.06	4.5±1.5
J	0.01+0.008/-0.004	0.25+0.2/-0.1
K	0.12 Max.	3.0 Max.
L	0.3 Max.	7.5 Max.

11 VLA553-01R, VLA553-02R

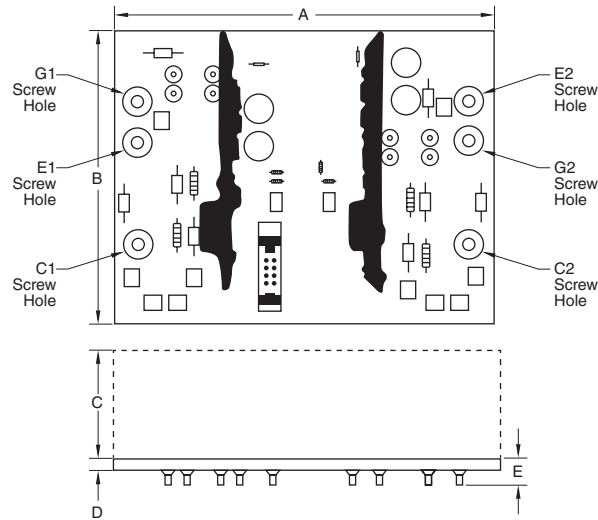

Dim.	Inches	Millimeters
A	5.63	143.0
B	4.33	110.0
C	1.69 Max.	43.0 Max.

Dim.	Inches	Millimeters
D	0.063	1.6
E	0.12 Max.	3.0 Max.

12 VLA567-01R

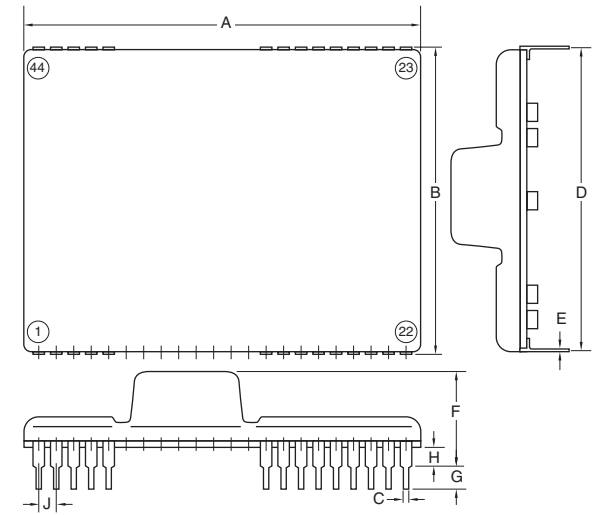

Dim.	Inches	Millimeters
A	2.44 Max.	62.0 Max.
B	1.89 Max.	48.0 Max.
C	0.02±0.0039	0.5±0.1
D	1.8	45.72
E	0.01+0.0067/-0.0039	0.27+0.17/-0.1

Dim.	Inches	Millimeters
F	0.67 Max.	17.0 Max.
G	0.177±0.06	4.5±1.5
H	0.14	3.5
J	0.1	2.54

DC-DC CONVERTERS

Applications Include:

- Industrial Power Conversions
- Isolated Power for IPMs

Packages:

- Dual-In-Line
- Prototype IPM Development Kit
- SIP

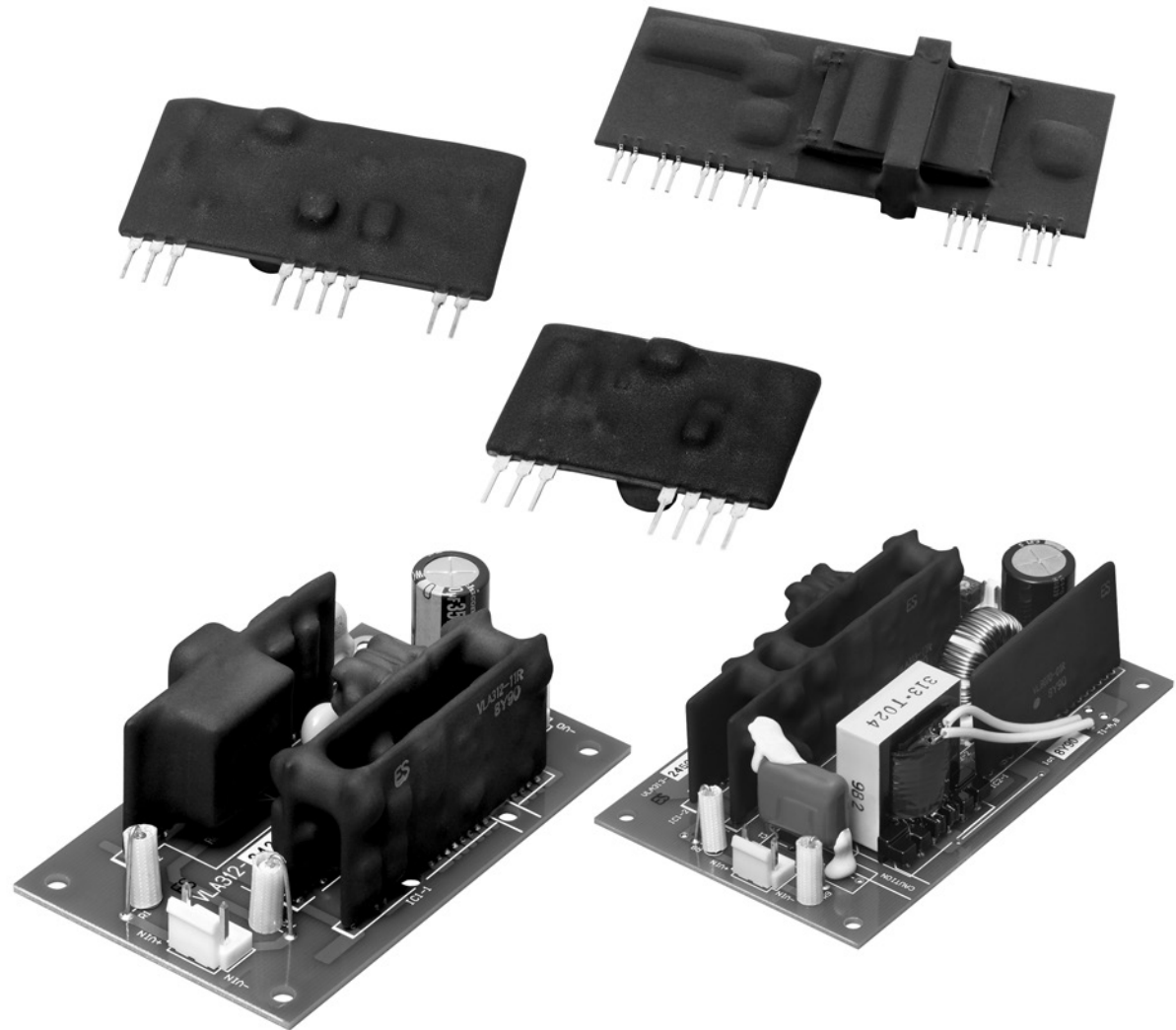

TABLE OF CONTENTS

DC-to-DC Converter Modules	N-2
Prototype IPM Interface Boards	N-3
Outline Drawings	N-4

DC-DC
Converters

Gate Drivers
& IPM
Interface

Custom
Modules

IGBT
Assemblies

Assemblies

Fast Recovery
Diode Modules

Thyristor &
Diode
Modules

Discrete
Rectifiers

Discrete
Thyristors

DIPIPM

IPMs

MOSFET
Modules

Hybrid
& SiC
Modules

IGBTs

DC-to-DC Converter Modules for Gate Drive and IPM Control Power

Type	Isolated	Isolated Voltage V_{RMS} (Volts)	Input (V_{DC})	Output(s) (Volts A ma)	Power Watts	Primary Application	Outline Drawings	
							Number	Page
M57140-01	Yes	Primary to Secondary = 2500V Secondary to Secondary = 1500V	18-22	4 x 15V	3.0	Isolated Power for IPM Modules	1	N-4
M57182N-315	No	Step Down Converter	140-380	15V	3.0	DIP Control Power	2	N-4
M57184N-715B	No	Step Down Converter	140-380	5, 15V	6.25	DIP Control Power	3	N-4
VLA106-15151	Yes	Primary to Secondary = 2500V	12-18	15V	1.5	Isolated Power for IPM Modules	4	N-5
VLA106-15242	Yes	Primary to Secondary = 2500V	12-18	18V	1.5	Isolated Power for Hybrid Gate Drivers	4	N-5
VLA106-24151	Yes	Primary to Secondary = 2500V	21.6 - 26.4	15V	2.4	Isolated Power for IPM Modules	4	N-5
VLA106-24154	Yes	Primary to Secondary = 2500V	21.6 - 26.4	15V	2.4	Isolated Power for IPM Modules	5	N-5
VLA106-24242	Yes	Primary to Secondary = 2500V	21.6 - 26.4	24V	4.5	Isolated Power for Hybrid Gate Drivers	4	N-5
VLA107-644R	Yes	Primary to Secondary = 2500V	12-24	4x15V	7.2	Isolated Power for IPM Modules	7	N-6
VLA107-677R	Yes	Primary to Secondary = 2500V	12-24	4x15V	11.5	Isolated Power for IPM Modules	7	N-6
VLA312-2425	Yes	Primary to Secondary = 2500V	475 - 850	24V	25.2	Pre-regulator for 460VAC Industrial Controls	8	N-6
VLA313-2450A	Yes	Primary to Secondary = 2500V	400 - 900	24V	50.4	Pre-regulator for 460VAC Industrial Controls	6	N-5

VLA106-15151, VLA106-24151, VLA106-24154

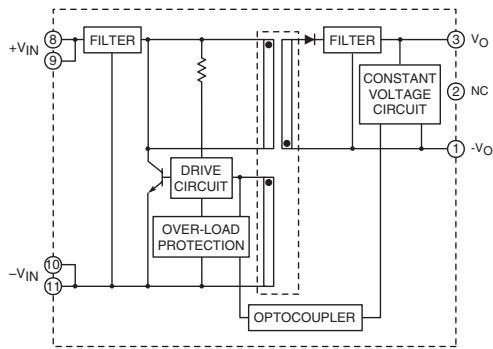

VLA312-2425, VLA313-2450A

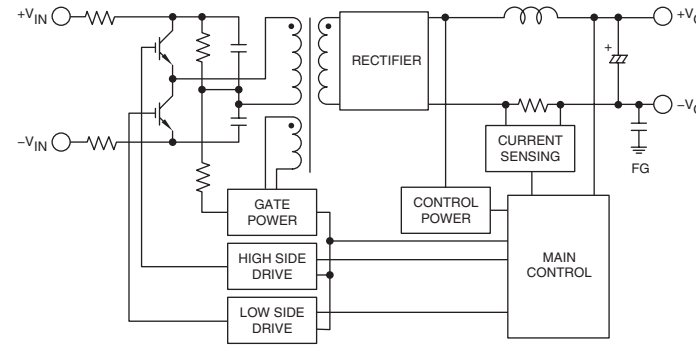

VLA106-15242, VLA106-24242

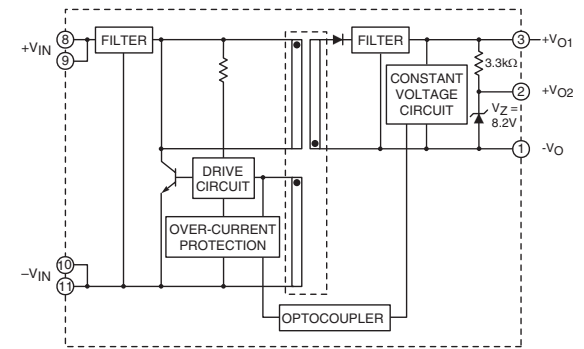

VLA107-644R, VLA107-677R

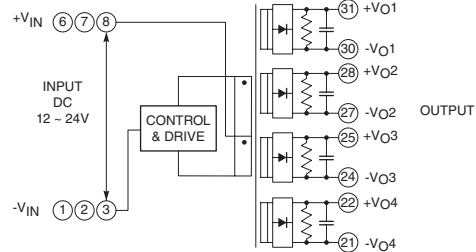

M57140-01

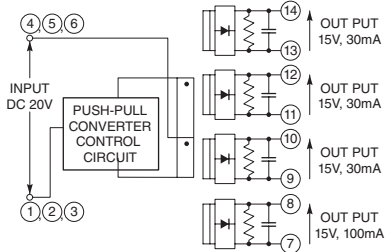

M57184N-715B

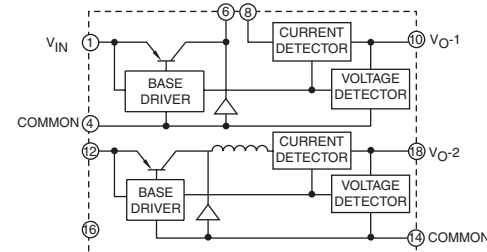

M57182N-315

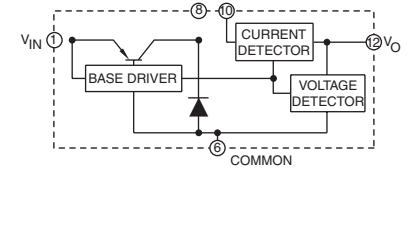

Prototype IPM Interface Boards

Part Number	L-Series IPM Part Number	Voltage Volts	Current Amperes	Package	Recommended DC-to-DC Converter*
BP7A-LS**	PM50(#L1(*)060	600	50	A or B	VLA106-24151 x 4pc.
BP7B-LS	PM75(#L1(*)060	600	75	C	VLA106-24151 x 3pc.
	PM100(#L1(*)060	600	100		
	PM150(#L1(*)060	600	150		
BP7A-LB**	PM200(#L1(*)060	600	200	C	VLA106-24151 x 3pc.
BP7B-LB	PM300(#L1(*)060	600	300	D	VLA106-24154 x 1pc.
BP6A-L	PM450CLA060	600	450	D	VLA106-24151 x 6pc.
	PM600CLA060	600	600		

Part Number	L-Series IPM Part Number	Voltage Volts	Current Amperes	Package	Recommended DC-to-DC Converter*
BP7A-LS**	PM25(#L1(*)120	1200	25	A or B	VLA106-24151 x 4pc.
BP7B-LS	PM50(#L1(*)120	1200	50	C	VLA106-24151 x 3pc.
	PM75(#L1(*)120	1200	75		
BP7A-LB**	PM100(#L1A120	1200	100	C	VLA106-24151 x 3pc.
BP7B-LB	PM150(#L1A060	1200	150	D	VLA106-24154 x 1pc.
BP6A-L	PM200CLA120	1200	200	D	VLA106-24151 x 6pc.
	PM300CLA120	1200	300		
	PM450CLA120	1200	450		

*Interface board come with parts noted here and are not assembled.

**For 3.3V Logic

1 M57140-01

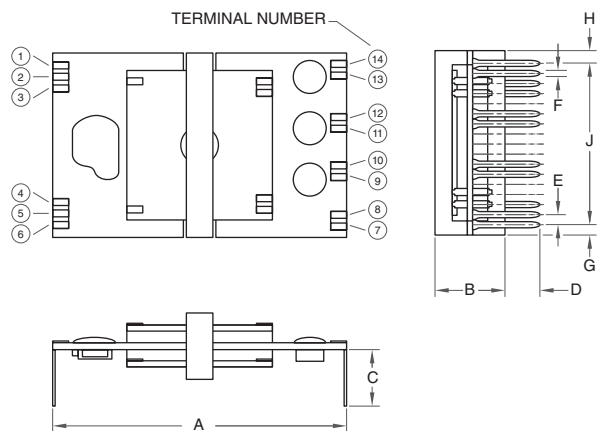

Dim.	Inches	Millimeters
A	2.03	51.5
B	0.71	18.0
C	0.39±0.06	12.5±1.5
D	0.18±0.06	4.5±1.5
E	0.07	1.8

Dim.	Inches	Millimeters
F	0.02	0.55
G	0.08	2.1
H	0.08	2.1
J	1.13	28.8

2 M57182N-315

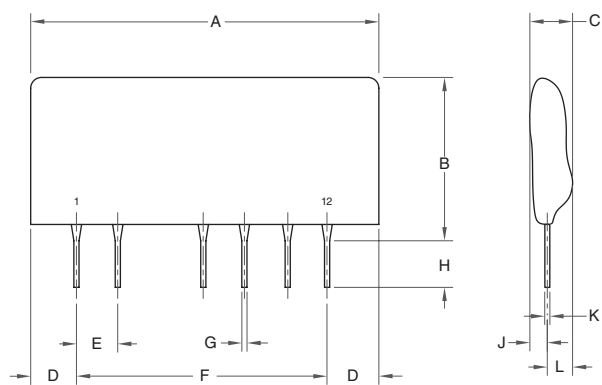

Dim.	Inches	Millimeters
A	1.38 Max.	35.0 Max.
B	0.79 Max.	20.0 Max.
C	0.34 Max.	8.5 Max.
D	0.14 Max.	3.5 Max.
E	0.02	5.08
F	1.10	27.94

Dim.	Inches	Millimeters
G	0.02	0.55±0.1
H	0.18±0.6	4.5±1.5
J	0.15 Max.	3.8 Max.
K	0.01±0.008	0.35±0.02
L	0.20 Max.	5.0 Max.

3 M57184N-715B

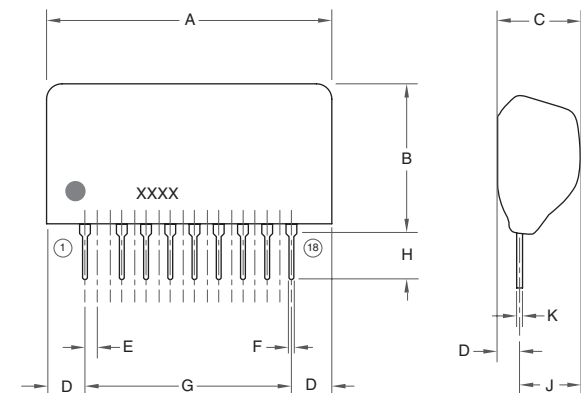

Dim.	Inches	Millimeters
A	2.05 Max.	52.0 Max.
B	0.95 Max.	24.0 Max.
C	0.47 Max.	12.0 Max.
D	0.18 Max.	4.5 Max.
E	0.01	2.54

Dim.	Inches	Millimeters
F	0.02±0.004	0.55±0.1
G	1.70	43.18
H	0.16±0.4	4.0±1.0
J	0.3 Max.	7.5 Max.
K	0.01±0.008	0.35±0.2

4 VLA106-15151, VLA106-15242,
VLA106-24151, VLA106-24242

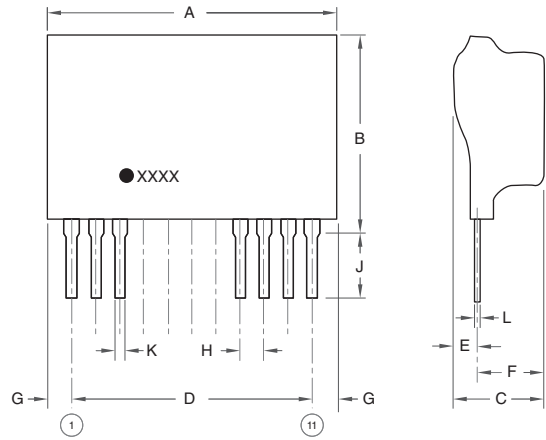

Dim.	Inches	Millimeters
A	1.3	33.0
B	0.945	24.0
C	0.71	18.0
D	1.0	25.4
E	0.22	5.5
F	0.53	13.5

Dim.	Inches	Millimeters
G	0.18	4.5
H	0.10	2.54
J	0.18±0.06	4.5±1.5
K	0.02+0.004/-0.002	0.5+0.1/-0.05
L	0.01+0.01/-0.002	0.25+0.2/-0.05

Note: All dimensions listed are maximums except D.

5 VLA106-24154

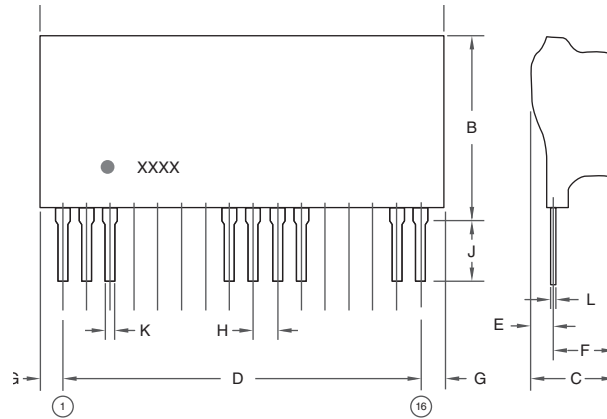

Dim.	Inches	Millimeters
A	1.87	47.5
B	0.945	24.0
C	0.71	18.0
D	1.60	40.64
E	0.22	5.5
F	0.53	13.5

Note: All dimensions listed are maximums except D.

Dim.	Inches	Millimeters
G	0.18	4.5
H	0.10	2.54
J	0.18±0.06	4.5±1.5
K	0.02+0.004/-0.002	0.5+0.1/-0.05
L	0.01+0.01/-0.002	0.25+0.2/-0.05

6 VLA313-2450A

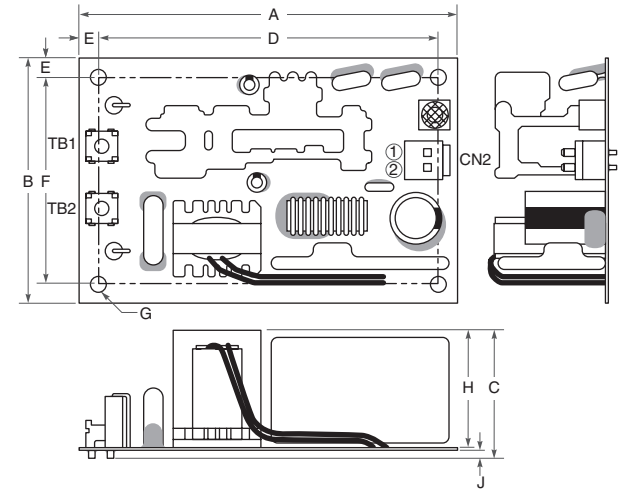

CONNECTOR

Parts No.	Polarity
TB1 (OT-047 M3, OSADA)	+VIN
TB2 (OT-047 M3, OSADA)	-VIN
CN2 (B2P-VH, JST)	① +VO ② -VO

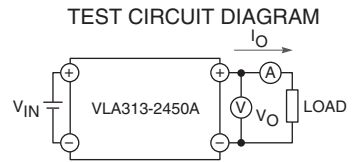

Dim.	Inches	Millimeters
A	4.53±0.012	115.0±0.3
B	2.76±0.012	70.0±0.3
C	1.42 Max.	36.0 Max.
D	4.13±0.012	105.0±0.3
E	0.2	5.0

Dim.	Inches	Millimeters
F	2.36±0.012	60.0±0.3
G	0.14 Dia.	3.5 Dia.
H	1.26 Max.	32.0 Max.
J	0.12 Max.	3.0 Max.

7 VLA107-644R, VLA107-677R

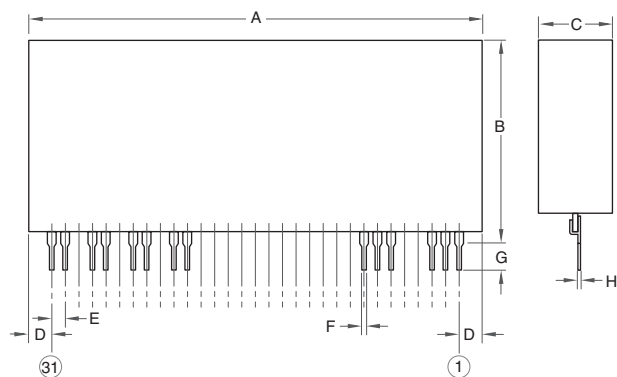

Dim.	Inches	Millimeters
A	3.42 Max.	87.0 Max.
B	1.53 Max.	39.0 Max.
C	0.55 Max.	14.0 Max.
D	0.21 Max.	5.5 Max.

Dim.	Inches	Millimeters
E	0.1	2.54
F	0.03±0.004	0.75±0.1
G	0.18±0.6	4.5±1.5
H	0.01+0.008/-0.004	0.5+0.2/-0.1

8 VLA312-2425

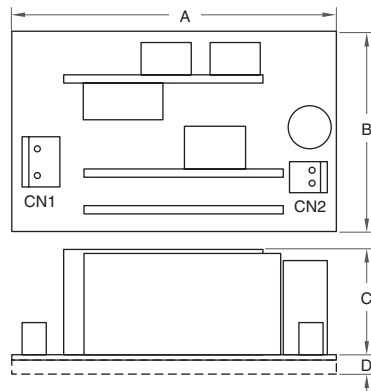

CONNECTOR

Parts No.	CN1 B2P3-VH, JST	CN2 B2P-VH, JST
Polarity (Pin 1)	-V _{IN}	+V _O
Polarity (Pin 2)	-	-V _O
Polarity (Pin 3)	+V _{IN}	-

TEST CIRCUIT DIAGRAM

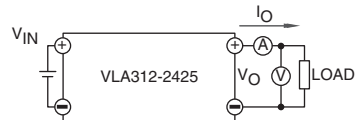

Dim.	Inches	Millimeters
A	3.54	90.0
B	2.16	55.0
C	1.38	35.0
D	0.20	5.0