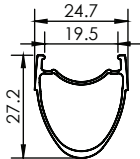
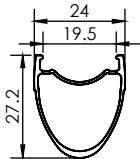
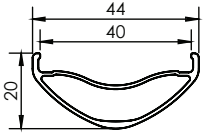
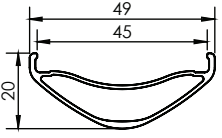

MY2016 AFTERMARKET RIM PROGRAM

ROAD 700c

MODEL:	R90 SL	R90 SL DISC
		
HOLE COUNT:	24/28/32	28/32
BRAKE:	RIM	DISC
TUBELESS READY:	YES	YES
SEAM:	WELDED	WELDED
MAX TENSION:	1200 N / 122 KgF	1200 N / 122 KgF
USE:	ROAD / CX / GRAVEL	ROAD / CX / GRAVEL
ETRTO:	622x19.5c	622x19.5c
WEIGHT:	455 +/-5%	445 +/-5%
ERD:	580++	580++

PLUS 27.5" / 29"

MODEL:	ARC 40	ARC 45
		
HOLE COUNT:	32	32
BRAKE:	DISC	DISC
TUBELESS READY:	YES	YES
SEAM:	WELDED	WELDED
MAX TENSION:	1200 N / 122 KgF	1200 N / 122 KgF
USE:	XC / TRAIL / AM	XC / TRAIL / AM
ETRTO:	584x40c / 622x40c	584x45c / 622x45c
WEIGHT:	596 +/-5% 633 +/-5%	650 +/-5% 690 +/-5%
ERD:	558++ / 596++	558++ / 596++

MOUNTAIN 27.5" / 29"

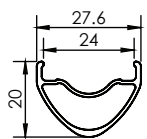
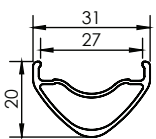
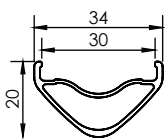
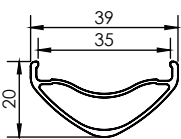
MODEL:	ARC 24	ARC 27	ARC 30	ARC 35
				
HOLE COUNT:	32	32	32	32
BRAKE:	DISC	DISC	DISC	DISC
TUBELESS READY:	YES	YES	YES	YES
SEAM:	WELDED	WELDED	WELDED	WELDED
MAX TENSION:	1200 N / 122 KgF	1200 N / 122 KgF	1200 N / 122 KgF	1200 N / 122 KgF
USE:	XC / TRAIL	TRAIL / AM	TRAIL / AM / ENDURO	TRAIL / AM / ENDURO
ETRTO:	584x24c / 622x24c	584x27c / 622x27c	584x30c / 622x30c	584x35c / 622x35c
WEIGHT:	425g +/-5% / 455 +/-5%	475 +/-5% / 515 +/-5%	490 +/-5% / 535 +/-5%	540 +/-5% / 578 +/-5%
ERD:	558++ / 596++	558++ / 596++	558++ / 596++	558++ / 596++