

Model # HLSS16R

16 Gallon Stainless Steel

COMBINATION RECYCLE / TRASH STEP CAN with AbsorbX® Odor Control

Offer quick and effective separation of trash and recyclables in stores, offices, lobbies, kitchens, cafeterias, and more, with the HLS Commercial® **Combination Trash Can and Recycle Bin**. The elegant, durable stainless steel complements any décor, while the slim design saves space. Color-coded, removable inner buckets and dual AbsorbX Odor Filters make it perfect for busy venues.



FEATURES

- ✓ SILENT AND GENTLE LID CLOSURE
- ✓ 2 COMPARTMENTS (8 GALLON/EA) FOR EASY SEPARATION OF RECYCLABLES
- ✓ 2 REMOVABLE COLOR-CODED INNER BUCKETS FOR CLEAR SEPARATION OF TRASH AND RECYCLING
- ✓ DOUBLE REPLACEABLE ODOR FILTERS ABSORB TRASH AND RECYCLING ODORS
- ✓ EFFICIENT, SPACE-SAVING DESIGN FOR A PERFECT FIT AGAINST THE WALL
- ✓ SIDE HANDLES FOR EASY TRANSPORTATION
- ✓ FINGERPRINT-PROOF AND SMUDGE-RESISTANT STAINLESS STEEL



For product details and pricing:



1-650-535-4378



hlscommercial.com

SPECIFICATIONS

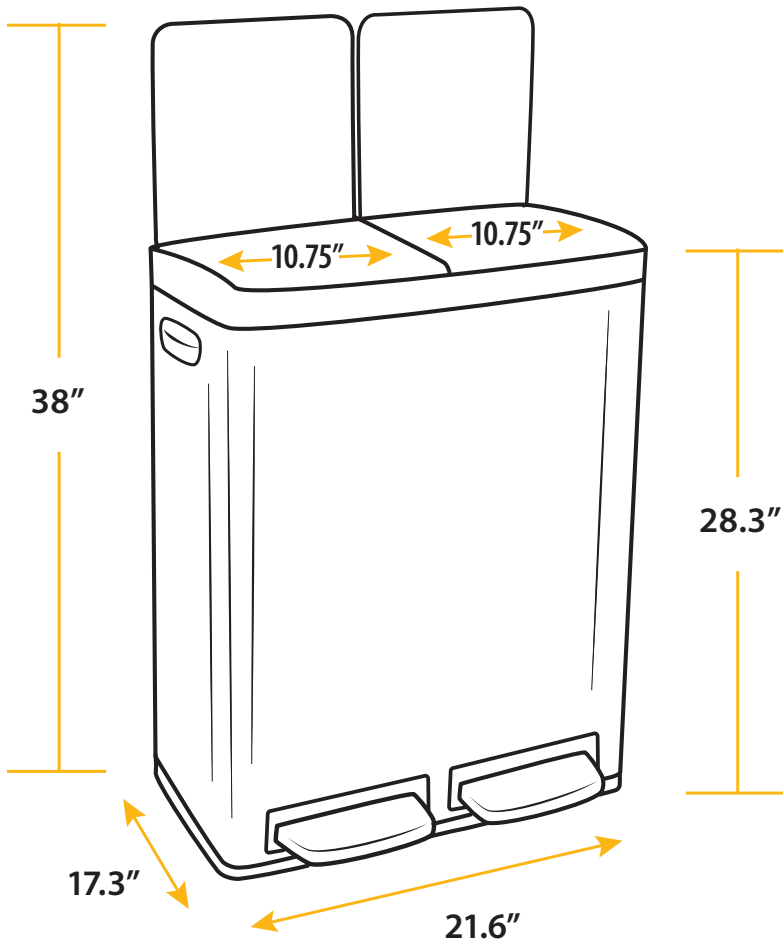

Dual AbsorbX® Replaceable Odor Filters



Model: HLSS16R

Dimensions: 17.3" L x 21.6" W x 28.3" H

Package Dimensions: 17.6" L x 21.6" W x 28.7" H

Product Weight: 19.6 lbs.

Package Weight: 24.6 lbs.

Capacity: 16 Gallons (60.5 Liters)

Material: Stainless Steel