

**Model # HLS18WRSL**

# 18 Gallon Stainless Steel

## **WINGS LID SENSOR TRASH CAN with AbsorbX® Odor Control**

Eliminate exposure to the illness-causing bacteria that live on trash can surfaces with this rectangular sensor operated trash can. Enhanced infrared sensor technology allows for hands-free lid open and close, promoting a healthier environment. The odor filter compartment houses the easy to replace AbsorbX® odor filter to absorb and neutralize trash odors. The large, 18 gallon capacity easily accommodates a day's worth of trash. It's perfect for high-traffic venues that require quick and easy disposal.



### **FEATURES**

- ✓ **NO-TOUCH LID OPERATION FOR ENHANCED HYGIENE**
- ✓ **DURABLE MATERIAL/CONSTRUCTION; EASY TO SERVICE**
- ✓ **WIDE OPENING ACCOMMODATES LARGE AND BULKY ITEMS**
- ✓ **REPLACEABLE ODOR FILTER ABSORBS TRASH ODORS**
- ✓ **SLIM AND SPACE-SAVING DESIGN**
- ✓ **TRASH BAG RETAINER RING KEEPS BAG IN PLACE AND OUT OF VIEW**
- ✓ **STAINLESS STEEL FINISH IS SMUDGE-RESISTANT AND EASY TO CLEAN**



For product details and pricing:



1-650-535-4378



[hlscommercial.com](http://hlscommercial.com)

# SPECIFICATIONS

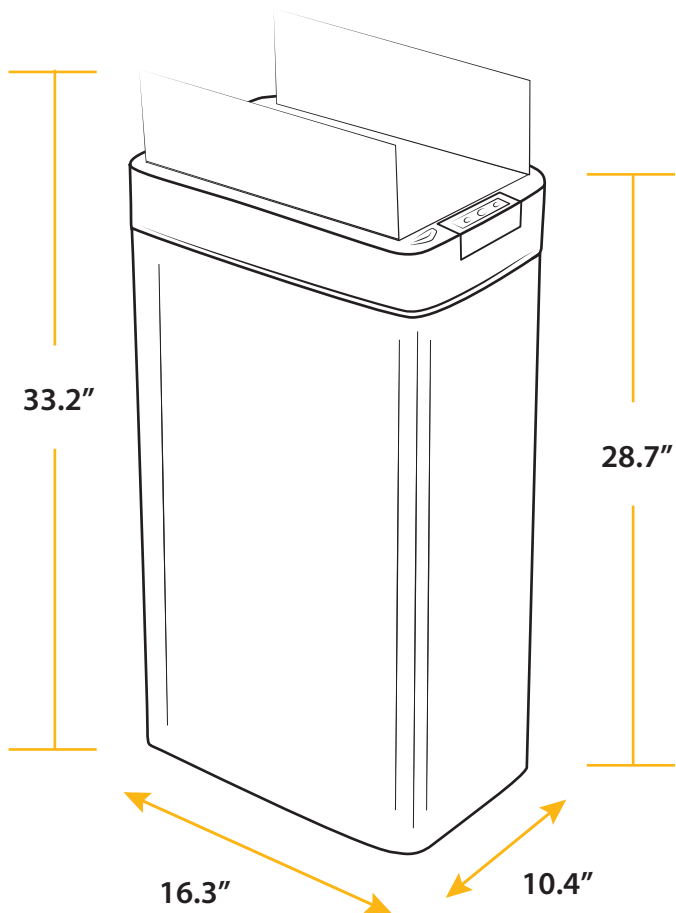

AbsorbX® Replaceable Odor Filter

**Model:** HLS18WRSL

**Dimensions:** 16.3" L x 10.4" W x 28.7" H

**Package Dimensions:** 17.9" L x 12.2" W x 31.5" H

**Product Weight:** 9.9 lbs.

**Package Weight:** 14.1 lbs.

**Capacity:** 18 Gallons (68 Liters)

**Material:** Stainless Steel / ABS Plastic (Top)