

18/23 Gallon Stainless Steel

ROUND SENSOR TRASH CAN with AbsorbX® Odor Control and Wheels

Eliminate exposure to the illness-causing bacteria that live on trash can surfaces with this rectangular sensor operated trash can. Enhanced infrared sensor technology allows for hands-free lid open and close, promoting a healthier environment. The dual odor filter compartments house the easy to replace AbsorbX® odor filters to absorb and neutralize trash odors. The bin has four removable wheels at the base, making it easy to transport. The brushed stainless steel can body finish is smudge-resistant, easy to clean, and complements any décor.



HLS18RC

HLS23RC

FEATURES

- ✓ NO-TOUCH LID OPERATION FOR ENHANCED HYGIENE
- ✓ WIDE OPENING ACCOMMODATES LARGE AND BULKY ITEMS
- ✓ DUAL ODOR FILTERS ABSORB TRASH ODORS
- ✓ TRASH BAG RETAINER RING KEEPS BAG IN PLACE AND OUT OF VIEW
- ✓ STAINLESS STEEL IS FINGERPRINT-PROOF AND EASY TO CLEAN



For product details and pricing:



1-650-535-4378



hlscommercial.com

SPECIFICATIONS

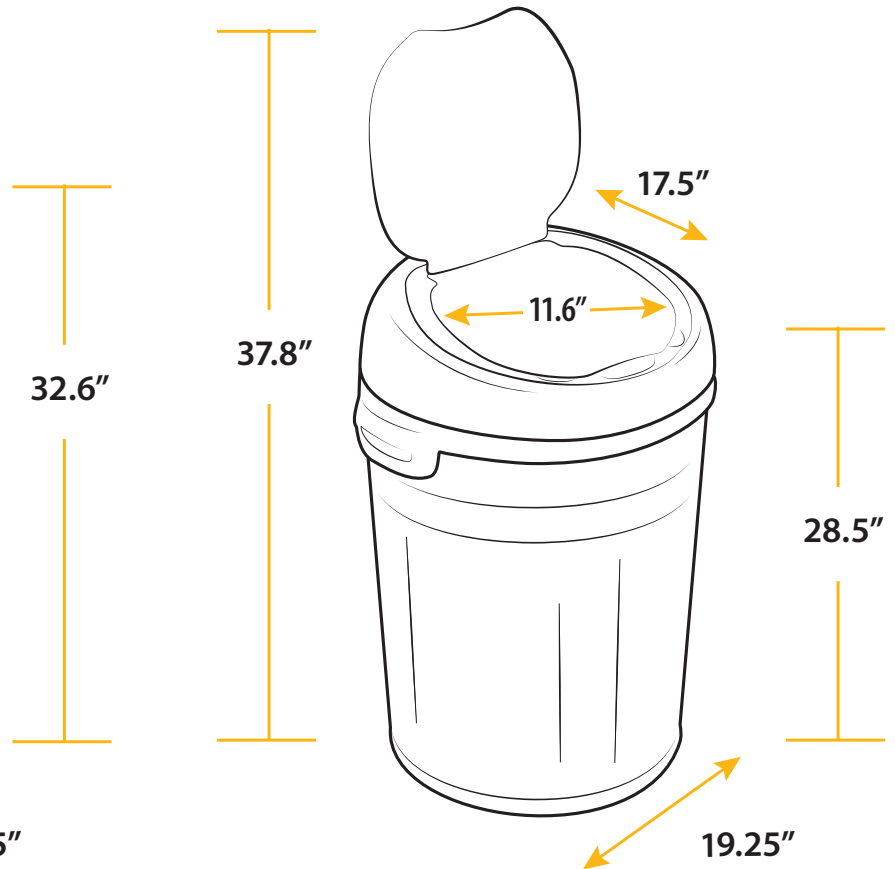
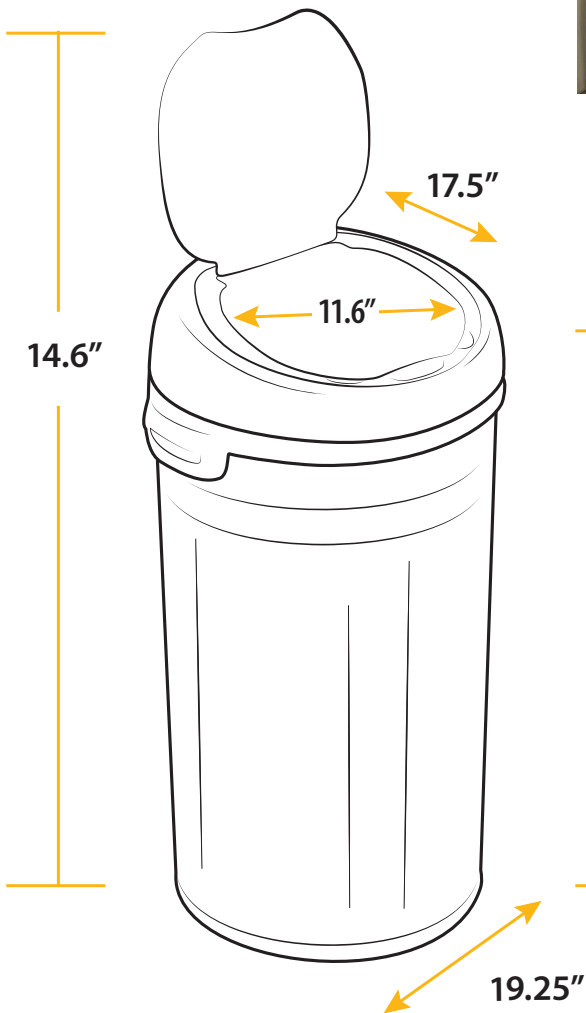

Model: HLS18RC

Dimensions:
19.25" L x 17.5" W x 28.5" H

Package Dimensions:
18" L x 18" W x 29" H

Product Weight: 12.2 lbs.

Package Weight: 17 lbs.

Capacity:
18 Gallons (68 Liters)

Material: Stainless Steel

Model: HLS23RC

Dimensions:
19.25" L x 17.5" W x 32.6" H

Package Dimensions:
18" L x 18" W x 33" H

Product Weight: 14 lbs.

Package Weight: 18 lbs.

Capacity:
23 Gallons (87 Liters)

Material: Stainless Steel