

Model # HLS16DCSS

16 Gallon Stainless Steel

COMBINATION RECYCLE/TRASH SENSOR CAN with Dual Compartments and Wheels

Make it easy to separate recycling and trash quickly and cleanly in high-traffic venues like cafeterias, lobbies, kitchens, stores, and more. It has two 8 gallon separated compartments with independent sensor lids. There are two removable inner buckets for easy disposal. The bin has four removable wheels at the base, making it easy to transport. The brushed stainless steel can body is smudge-resistant, easy to clean, and complements any décor. The ABS plastic top is durable and attractive..



FEATURES

- ✓ NO-TOUCH LID OPERATION FOR ENHANCED HYGIENE
- ✓ 2 COMPARTMENTS (8 GALLON/EA) FOR EASY SEPARATION OF WASTE
- ✓ REMOVABLE INNER BUCKETS WITH HANDLES FOR EASY EMPTYING
- ✓ TRASH BAG RETAINER RINGS KEEP BAGS IN PLACE AND OUT OF VIEW
- ✓ 4 REMOVABLE CASTER WHEELS FOR EASY MOBILITY
- ✓ FINGERPRINT-PROOF AND SMUDGE-RESISTANT STAINLESS STEEL



For product details and pricing:

☎ 1-650-535-4378 🌐 hlscommercial.com

SPECIFICATIONS

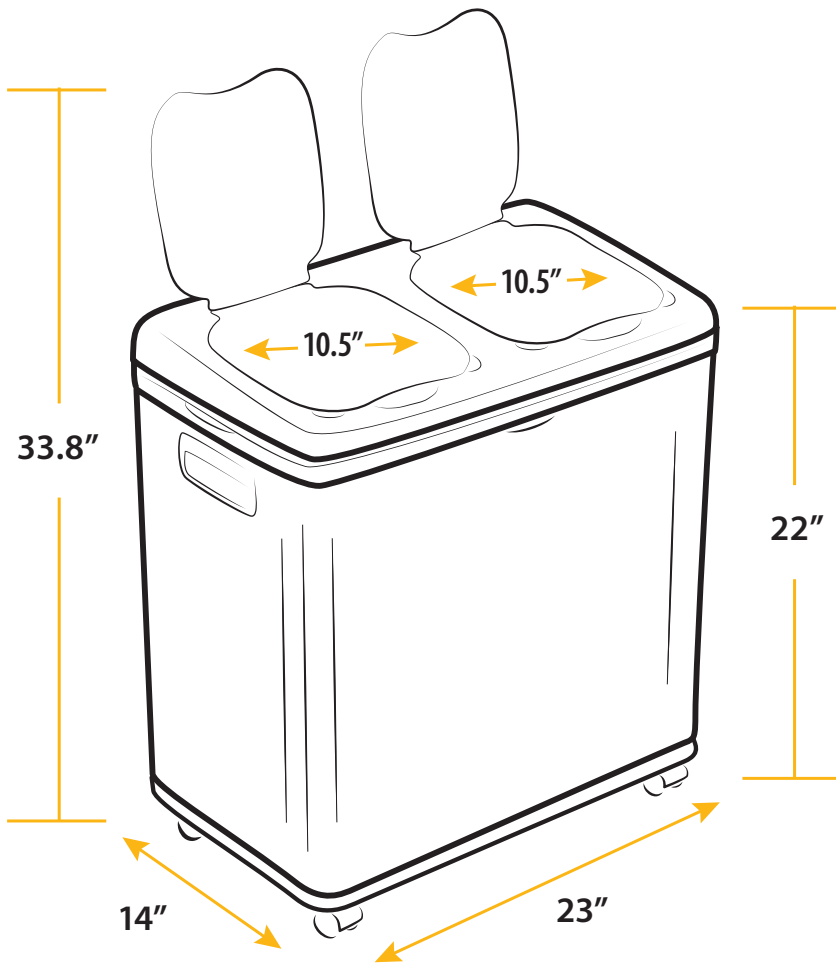

Model: HLS16DCSS

Dimensions: 14" L x 23" W x 22" H

Package Dimensions: 16" L x 24" W x 24" H

Product Weight: 18.2 lbs.

Package Weight: 23 lbs.

Capacity: 16 Gallons (60.5 Liters)

Material: Stainless Steel / ABS Plastic (Top)