

13/18 Gallon Stainless Steel

STEP CAN WITH AIRSTEP TECHNOLOGY AND ABSORBX® ODOR CONTROL

13 / 18 Gallon Step Trash Can with AirStep™ Technology is the most sophisticated step trash can ever made. From its low-effort, ergonomic step-activated open to its gentle, silent close, this trash can offers the most reliable and consistently pleasant available in a step trash can. The pedal has been designed to perform perfectly for over 200,000 steps; that's years of rigorous, daily use! Designed for maximum space efficiency, it provides 25% more capacity than comparably sized trash cans.



HLS13SS

HLS18SS

FEATURES

- ✓ **LARGE 13 AND 18 GALLON CAPACITY**
- ✓ **ERGONOMICALLY DESIGNED PEDAL REQUIRES MINIMAL FORCE**
- ✓ **SILENT AND GENTLE LID CLOSE**
- ✓ **BACK HANDLE FOR EASY TRANSPORTATION**
- ✓ **EFFICIENT, SPACE-SAVING DESIGN**
- ✓ **VINYL TRIM BASE TO PROTECT FLOOR SURFACE**
- ✓ **FINGERPRINT-PROOF AND SMUDGE-RESISTANT STAINLESS STEEL**



For product details and pricing:



1-650-535-4378



hlscommercial.com

SPECIFICATIONS

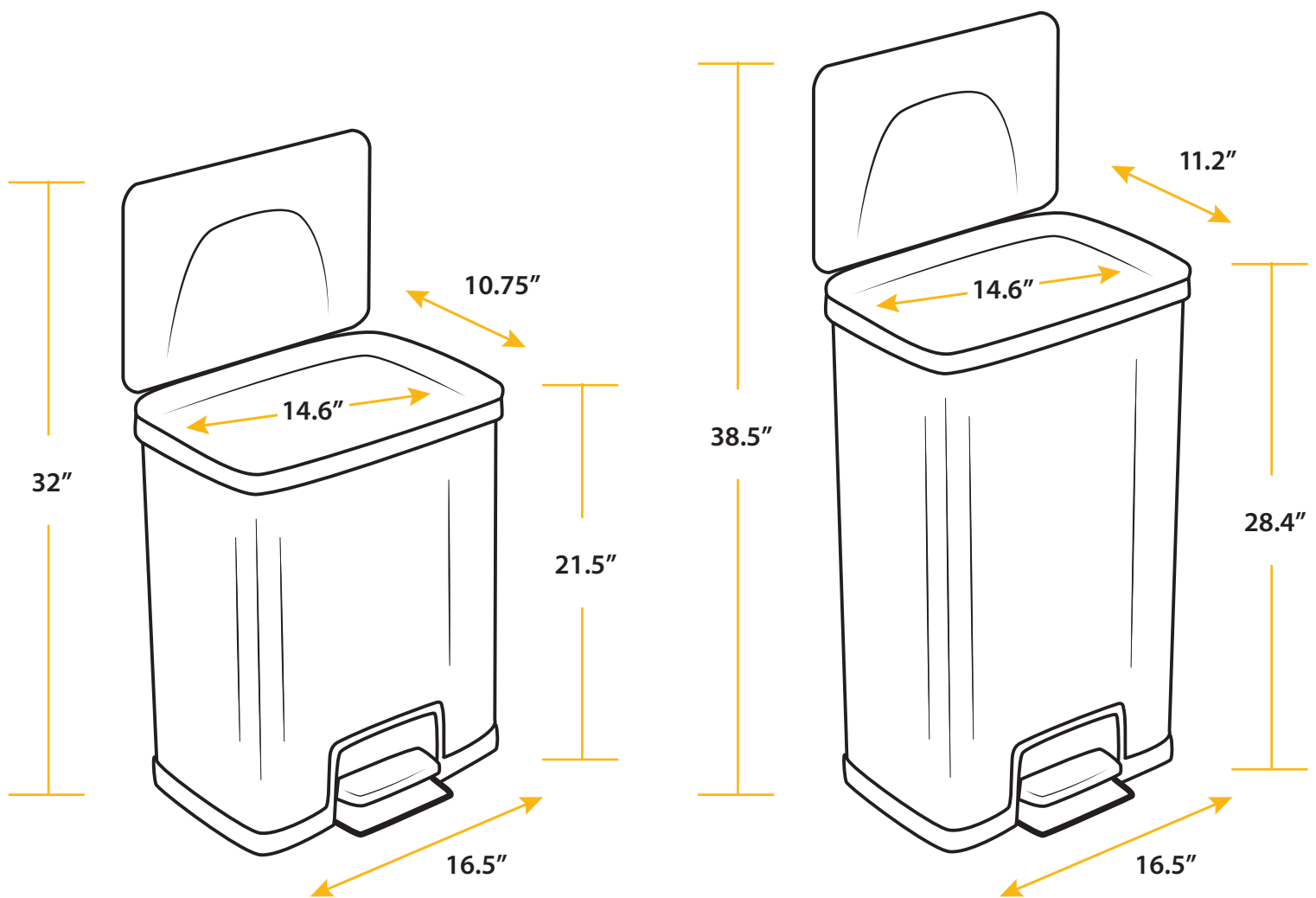

Model: HLS13SS

Dimensions:

10.5" L x 16.5" W x 21.5" H

Package Dimensions:

18.5" L x 14" W x 25.5" H

Product Weight: 11 lbs.

Package Weight: 14.75 lbs.

Capacity:

13 Gallons (49 Liters)

Material: Stainless Steel

Model: HLS18SS

Dimensions:

11.2" L x 16.5" W x 28.4" H

Package Dimensions:

18.5" L x 14" W x 31.75" H

Product Weight: 11 lbs.

Package Weight: 17 lbs.

Capacity:

18 Gallons (68 Liters)

Material: Stainless Steel