

13 Gallon Stainless Steel

TAP PEDAL SENSOR TRASH CAN with AbsorbX[®] Odor Control

One tap is all it takes! **Power Trash Can with Tap Sensor Technology** is the smartest, most effortless pedal can ever invented. Unlike step-cans that require you to apply foot pressure and hold the pedal down for the lid to open, our patented technology opens, then automatically closes, the lid with just one tap. Or, double tap the pedal for a timed, five-minute lid open (or tap and rest your foot on the pedal for traditional step-can function). The enhanced, energy-saving technology extends the life of the battery up to 2 years with just 4 D sized batteries. The elegant, fingerprint proof, brushed stainless steel finish and choice of three trim colors complements any room. It's the smartest, easiest tap-on trash can you will ever use.



FEATURES

- ✓ **PATENTED, NO-TOUCH ONE-TAP SENSOR LID OPERATION FOR ULTIMATE CONVENIENCE AND ENHANCED HYGIENE**
- ✓ **SMART-SENSOR FOR 3 FUNCTIONS: SHORT, LONG, AND MANUAL LID OPEN**
- ✓ **REPLACEABLE ABSORBX[®] ODOR FILTER NEUTRALIZES ODORS**
- ✓ **ELEGANT DESIGN WITH 3 TRIM COLOR OPTIONS: BLACK, RED, WHITE**
- ✓ **TRASH BAG RETAINER RING KEEPS BAG IN PLACE AND OUT OF VIEW**
- ✓ **CONVENIENT CARRY HANDLE MAKES IT EASY TO MOVE**
- ✓ **STAINLESS STEEL IS FINGERPRINT-PROOF AND EASY TO CLEAN**



For product details and pricing:



1-650-535-4378



hlscommercial.com

SPECIFICATIONS

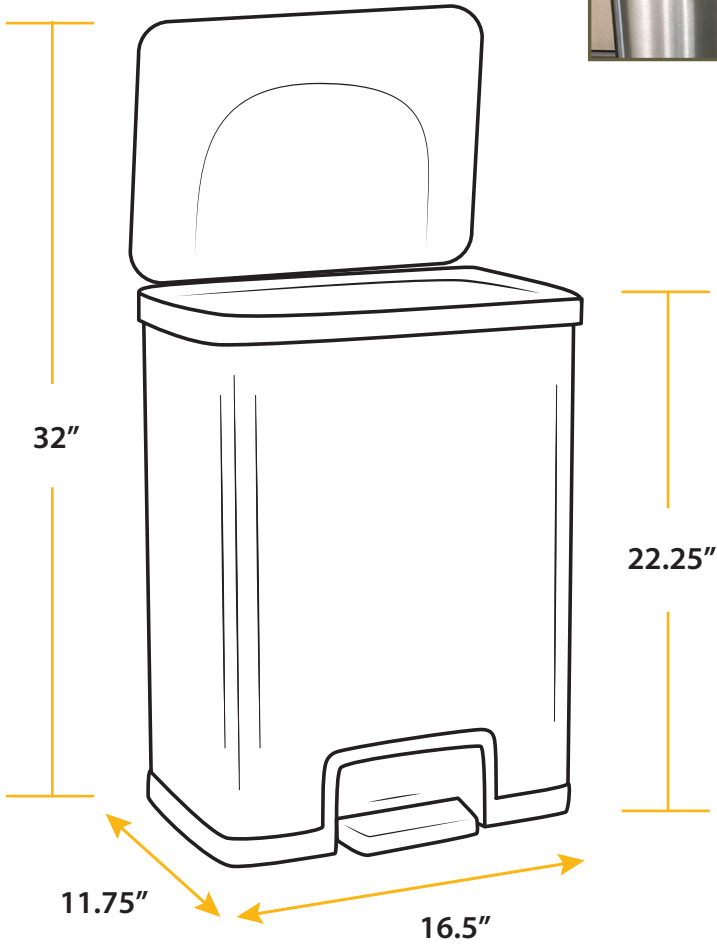

AbsorbX® Replaceable Odor Filter

Model: HLS13SB / HLS13SR / HLS13SW

Dimensions: 11.75" L x 16.5" W x 22.25" H

Package Dimensions: 14" L x 18.5" W x 25.5" H

Product Weight: 9.8 lbs.

Package Weight: 14.75 lbs.

Capacity: 13 Gallons (49 Liters)

Material: Stainless Steel / ABS Plastic (Top)