

**Model # HLS13HX**

# **13 Gallon/49 Liter Stainless Steel SEMI-ROUND SENSOR TRASH CAN**

Eliminate exposure to the illness-causing bacteria that live on trash can surfaces with this touchless, sensor-operated trash can. Enhanced infrared sensor technology allows for hands-free lid open and close, promoting a healthier environment. The odor filter compartment houses the easy to replace AbsorbX® odor filter to absorb and neutralize trash odors. An extra-large 12.5" opening easily accommodates large and bulky items. It's perfect for high-traffic venues that require quick and easy disposal. It also features an enhanced lid hinge mechanism and air vent holes for effortless trash bag removal.



## **FEATURES**

- ✓ **NO-TOUCH LID OPERATION FOR ENHANCED HYGIENE**
- ✓ **DURABLE MATERIAL/CONSTRUCTION; EASY TO SERVICE**
- ✓ **WIDE OPENING ACCOMMODATES LARGE AND BULKY ITEMS**
- ✓ **REPLACEABLE ODOR FILTER ABSORBS TRASH ODORS**
- ✓ **SLIM AND SPACE-SAVING DESIGN**
- ✓ **TRASH BAG RETAINER RING KEEPS BAG IN PLACE AND OUT OF VIEW**
- ✓ **STAINLESS STEEL IS FINGERPRINT-PROOF AND EASY TO CLEAN**



For product details and pricing:



1-650-535-4378



hlscommercial.com

# SPECIFICATIONS

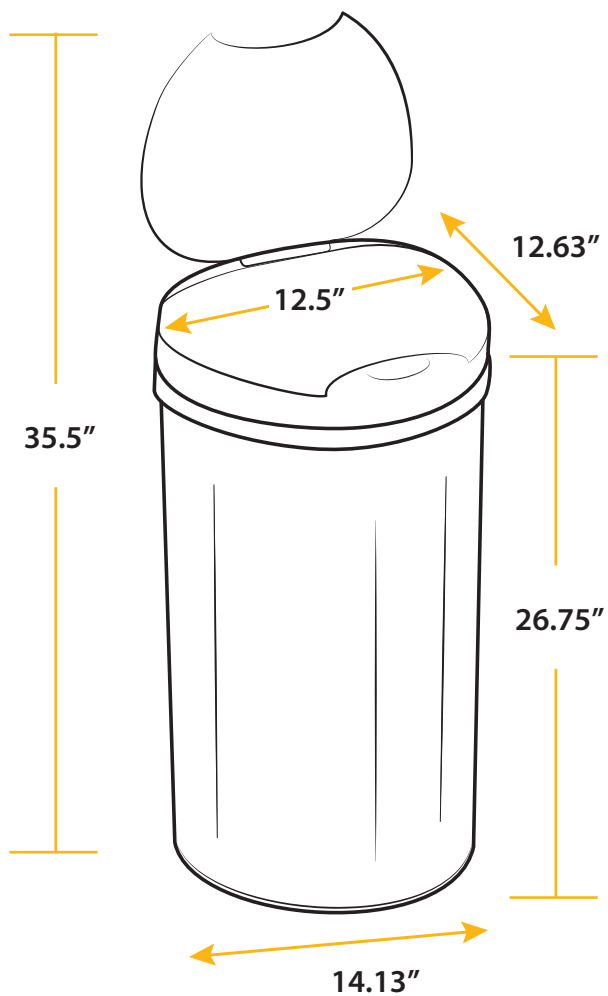

AbsorbX® Replaceable  
Odor Filter

**Model:** HLS13HX

**Dimensions:** 12.63" L x 14.13" W x 26.75" H

**Package Dimensions:** 16" L x 14" W x 28" H

**Product Weight:** 8.8 lbs.

**Package Weight:** 10 lbs.

**Capacity:** 13 Gallons (49 Liters)

**Material:** Stainless Steel / ABS Plastic (Top)