

## 5.3 Gallon/20 Liter Stainless Steel COMBO RECYCLE BIN / TRASH CAN

**HLS Commercial 5.3 Gallon / 20 Liter Dual Compartment Recycle Bin / Trash Can Combo Unit** makes it easy to separate trash and recycling quickly and easily. Perfect for hotels, offices, or home kitchens. Two separate, color-coded buckets clearly indicate where to place recyclables and where to place trash. Premium Features include: two removable, color-coded buckets; slim, space-efficient design fits perfectly under desks, in restrooms, or in the kitchen; each bucket holds 2.5 Gallons; elegant and stylish stainless steel can body is fingerprint-proof and smudge-resistant, while the ABS plastic lid is durable and easy to clean; convenient carry handle; fits standard size trash bag liners.



### FEATURES

- ✓ DUAL-COMPARTMENTS FOR EASY SEPARATION OF RECYCLING AND TRASH
- ✓ COLOR CODED REMOVABLE INNER BUCKETS
- ✓ STAINLESS STEEL BODY, ABS PLASTIC LID
- ✓ FOR HOTEL, OFFICE, UNDER THE DESK USE
- ✓ EASY TO SERVICE
- ✓ SPACE-SAVING DESIGN
- ✓ FITS STANDARD SIZE LINERS

# SPECIFICATIONS

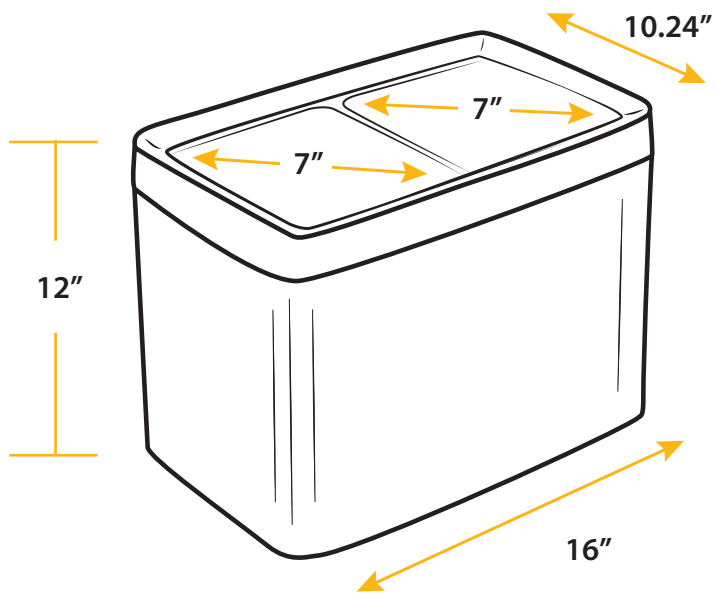

**Model:** HLS05DRO

**Dimensions:** 16" L x 10.24" W x 12" H

**Package Dimensions:** 17.9" L x 12" W x 13.8" H

**Product Weight:** 4.6 lbs.

**Package Weight:** 6.4 lbs.

**Capacity:** 5.3 Gallons (20 Liters)

**Material:** Stainless Steel