

2.5/4 Gallon Stainless Steel

RECTANGULAR SENSOR TRASH CAN with AbsorbX® Odor Control

Eliminate exposure to the illness-causing bacteria that live on trash can surfaces with this touchless, sensor-operated trash can. Enhanced infrared sensor technology allows for hands-free lid open and close, promoting a healthier environment. The combined odor-stopping power of the AbsorbX® odor filter and the lemon scent fragrance cartridge makes this the perfect bin for restrooms, cubicles, and kitchens.



HLS04SS

HLS02SS

FEATURES

- ✓ NO-TOUCH LID OPERATION FOR ENHANCED HYGIENE
- ✓ COMPACT AND SPACE-SAVING DESIGN
- ✓ ABSORBX ODOR FILTER NEUTRALIZES ODORS AND FRAGRANCE CARTRIDGE FILLS THE AREA WITH THE SCENT OF FRESH-CUT LEMONS
- ✓ REMOVABLE BAG RETAINER RING KEEPS TRASH BAGS IN PLACE AND OUT OF VIEW
- ✓ FINGERPRINT-PROOF AND SMUDGE-RESISTANT STAINLESS STEEL



For product details and pricing:



1-650-535-4378



hlscommercial.com

SPECIFICATIONS

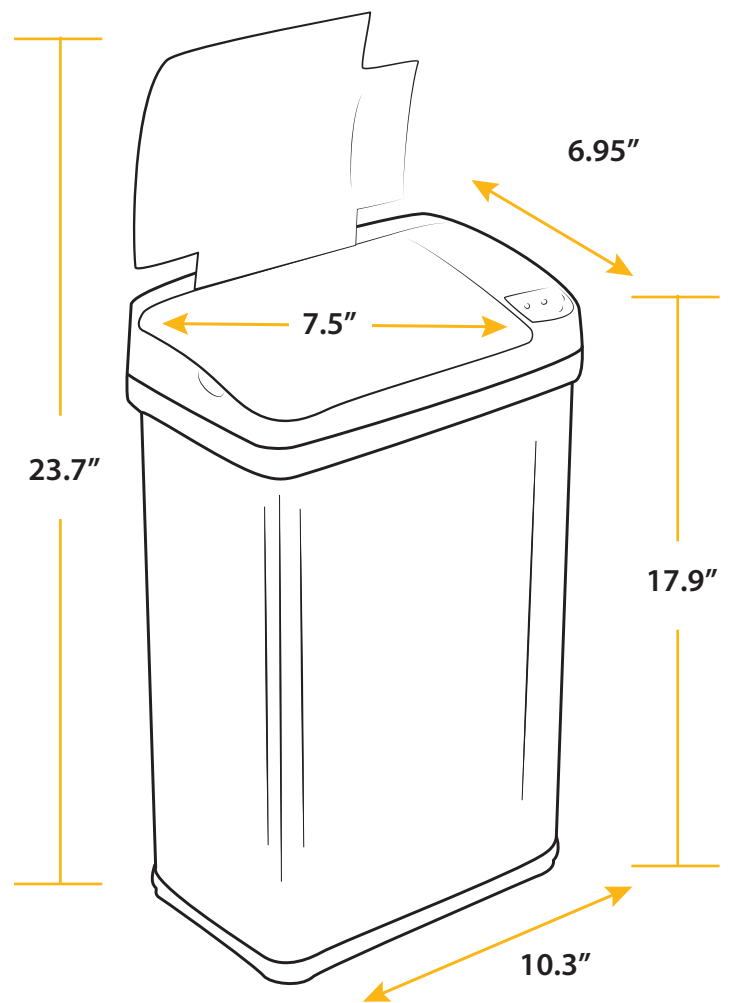
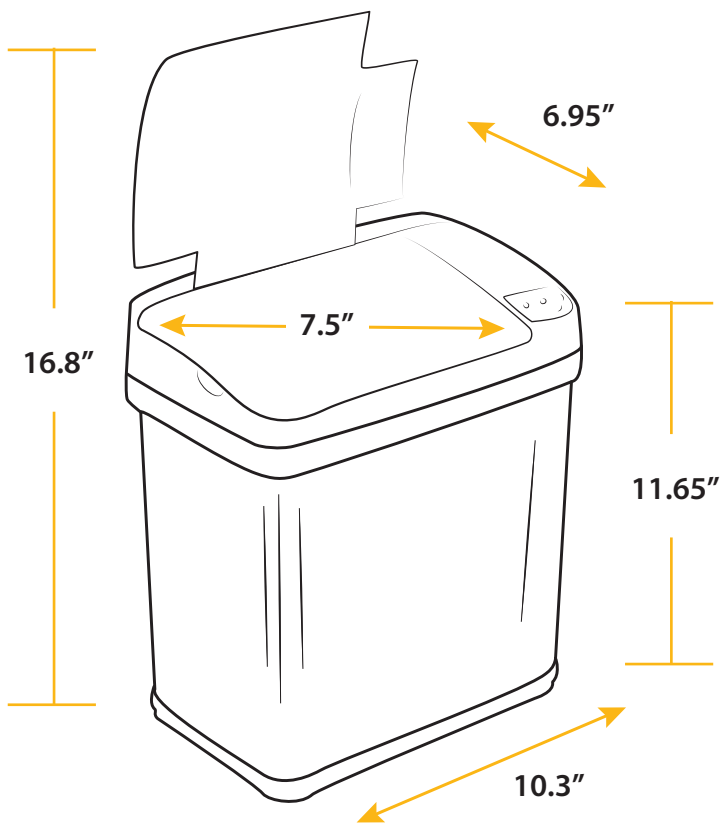

Model: HLS02SS

Dimensions:
6.95" L x 10.3" W x 11.65" H

Package Dimensions:
12.4" L x 9.25" W x 13.2" H

Product Weight: 2.75 lbs.

Package Weight: 4.1 lbs.

Capacity:
2.5 Gallons (9.5 Liters)

Material: Stainless Steel /
ABS Plastic (Top)

Model: HLS04SS

Dimensions:
6.95" L x 10.3" W x 17.9" H

Package Dimensions:
12.4" L x 9.25" W x 19.9" H

Product Weight: 3.65 lbs.

Package Weight: 5.7 lbs.

Capacity:
4 Gallons (15 Liters)

Material: Stainless Steel /
ABS Plastic (Top)