

# 50 Gallon / 189 Liter Stainless Steel ROUND DUAL SIDE-ENTRY OUTDOOR TRASH CAN with Removable Ashtray

Offer quick and effective waste disposal in patios, lobbies, dining areas, stores, or any high traffic venue with the **HLS Commercial® Round Dual Side-Entry Outdoor Trash Can with Removable Ashtray**. The elegant, durable stainless steel complements any décor, while the versatile round shape allows it to fit into any space and the two large side openings offer quick and convenient disposal.



**HLS50DSO**

## FEATURES

- ✓ DUAL SIDE-ENTRY OPENINGS FACILITATE EASY DISPOSAL IN BUSY SETTINGS
- ✓ WATER-RESISTANT AND RUST-RESISTANT 304-GRADE STEEL, IDEAL FOR OUTDOOR USE
- ✓ EXTRA-LARGE 50 GALLON CAPACITY
- ✓ REMOVABLE ASHTRAY HOLE COVER INCLUDED
- ✓ STAINLESS STEEL IS SMUDGE-RESISTANT



For product details and pricing:

☎ 1-650-535-4378 🌐 [hlscommercial.com](http://hlscommercial.com)

# SPECIFICATIONS

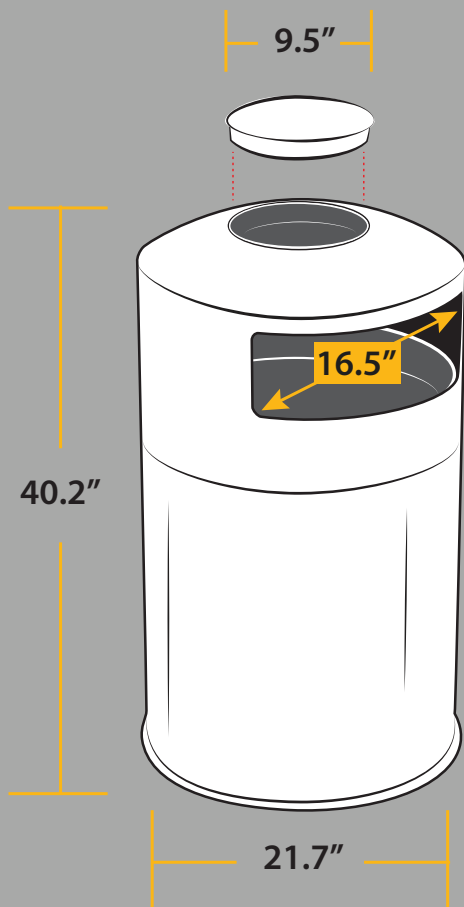

**Model:** HLS50DS0

**Use:** Outdoor

**Dimensions:** 21.7" L x 21.7" W x 40.2" H

**Package Dimensions:** 24.8" L x 24.8" W x 43.3" H

**Product Weight:** 29.1 lbs.

**Package Weight:** 39.02 lbs.

**Capacity:** 50 Gallons (189 Liters)

**Material:** Stainless Steel