

# 21 Gallon/80 Liter

## RECYCLE, COMPOST, AND TRASH BINS SET

Make it easy to sort compost, recycling, and trash quickly and cleanly in high-traffic venues like cafeterias, lobbies, kitchens, stores, and more. Paired with a 21 Gallon Stainless Steel Rectangular Open Top bin, the lids feature a push button release for easy access. The universally recognizable, color-coding and decals clearly mark the bins for proper sorting, while the dual AbsorbX® Odor Filters neutralize odors.



### FEATURES

- ✓ ATTRACTIVE RECYCLE, COMPOST, AND TRASH FULL SOLUTION FOR HIGH-TRAFFIC AREAS
- ✓ LARGE CAPACITY ACCOMMODATES BUSY COLLECTIONS SITES
- ✓ BINS CAN BE UTILIZED INDIVIDUALLY OR ALL TOGETHER
- ✓ ARRANGE HORIZONTALLY OR VERTICALLY AS NEEDED
- ✓ STAINLESS STEEL FINISH IS SMUDGE-RESISTANT AND EASY TO CLEAN

# SPECIFICATIONS

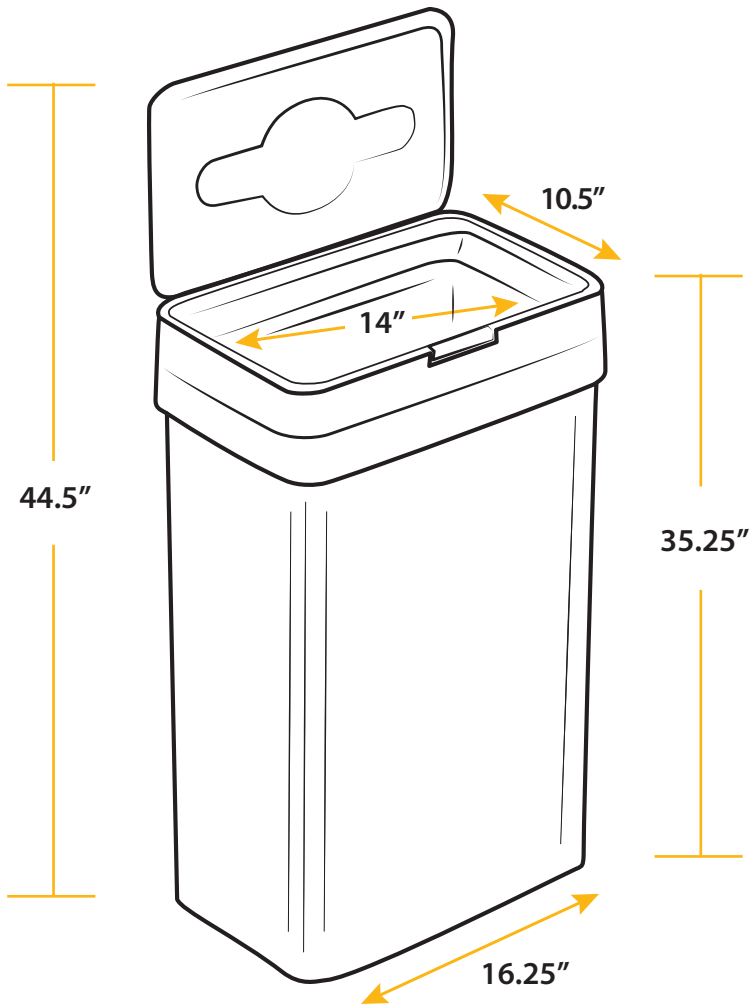

AbsorbX® Replaceable Odor Filters (2/can)

**Model:** HLS21UOTTRIO

**Dimensions:** 16.25" L x 10.5" W x 35.25" H (each)

**Package Dimensions:** 17.9" L x 12" W x 34.8" H (each)

**Product Weight:** 10.6 lbs. (each)

**Package Weight:** 15 lbs. (each)

**Capacity:** 21 Gallons / 80 Liters (each)

**Material:** Stainless Steel